

# TLV5606

## 2.7 V TO 5.5 V LOW POWER 10-BIT DIGITAL-TO-ANALOG CONVERTERS WITH POWER DOWN

SLAS259 – DECEMBER 1999

### features

- 10-Bit Voltage Output DAC
- Programmable Settling Time vs Power Consumption
  - 3  $\mu$ s in Fast Mode
  - 9  $\mu$ s in Slow Mode
- Ultra Low Power Consumption:
  - 900  $\mu$ W Typ in Slow Mode at 3 V
  - 2.1 mW Typ in Fast Mode at 3 V
- Differential Nonlinearity . . . <0.2 LSB Typ
- Compatible With TMS320 and SPI Serial Ports
- Power-Down Mode (10 nA)

- Buffered High-Impedance Reference Input
- Voltage Output Range . . . 2 Times the Reference Input Voltage
- Monotonic Over Temperature
- Available in MSOP Package

### applications

- Digital Servo Control Loops
- Digital Offset and Gain Adjustment
- Industrial Process Control
- Machine and Motion Control Devices
- Mass Storage Devices

### description

The TLV5606 is a 10-bit voltage output digital-to-analog converter (DAC) with a flexible 4-wire serial interface. The 4-wire serial interface allows glueless interface to TMS320, SPI, QSPI, and Microwire serial ports. The TLV5606 is programmed with a 16-bit serial string containing 4 control and 10 data bits. Developed for a wide range of supply voltages, the TLV5606 can operate from 2.7 V to 5.5 V.

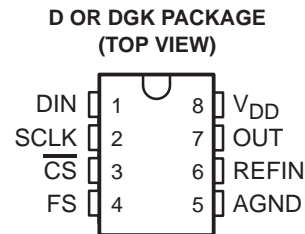

The resistor string output voltage is buffered by a x2 gain rail-to-rail output buffer. The buffer features a Class AB output stage to improve stability and reduce settling time. The settling time of the DAC is programmable to allow the designer to optimize speed versus power dissipation. The settling time is chosen by the control bits within the 16-bit serial input string. A high-impedance buffer is integrated on the REFIN terminal to reduce the need for a low source impedance drive to the terminal.

Implemented with a CMOS process, the TLV5606 is designed for single supply operation from 2.7 V to 5.5 V. The device is available in an 8-terminal SOIC package. The TLV5606C is characterized for operation from 0°C to 70°C. The TLV5606I is characterized for operation from -40°C to 85°C.

#### AVAILABLE OPTIONS

T <sub>A</sub>	PACKAGE	
	SMALL OUTLINE† (D)	MSOP† (DGK)
0°C to 70°C	TLV5606CD	TLV5606CDGK
-40°C to 85°C	TLV5606ID	TLV5606IDGK

† Available in tape and reel as the TLV5606CDR, TLV5606IDR, TLV5606CDGKR, and the TLV5606IDGKR



Please be aware that an important notice concerning availability, standard warranty, and use in critical applications of Texas Instruments semiconductor products and disclaimers thereto appears at the end of this data sheet.

PRODUCTION DATA information is current as of publication date. Products conform to specifications per the terms of Texas Instruments standard warranty. Production processing does not necessarily include testing of all parameters.



POST OFFICE BOX 655303 • DALLAS, TEXAS 75265

Copyright © 1999, Texas Instruments Incorporated

**TLV5606**  
**2.7 V TO 5.5 V LOW POWER 10-BIT DIGITAL-TO-ANALOG**  
**CONVERTERS WITH POWER DOWN**

SLAS259 – DECEMBER 1999

**functional block diagram**

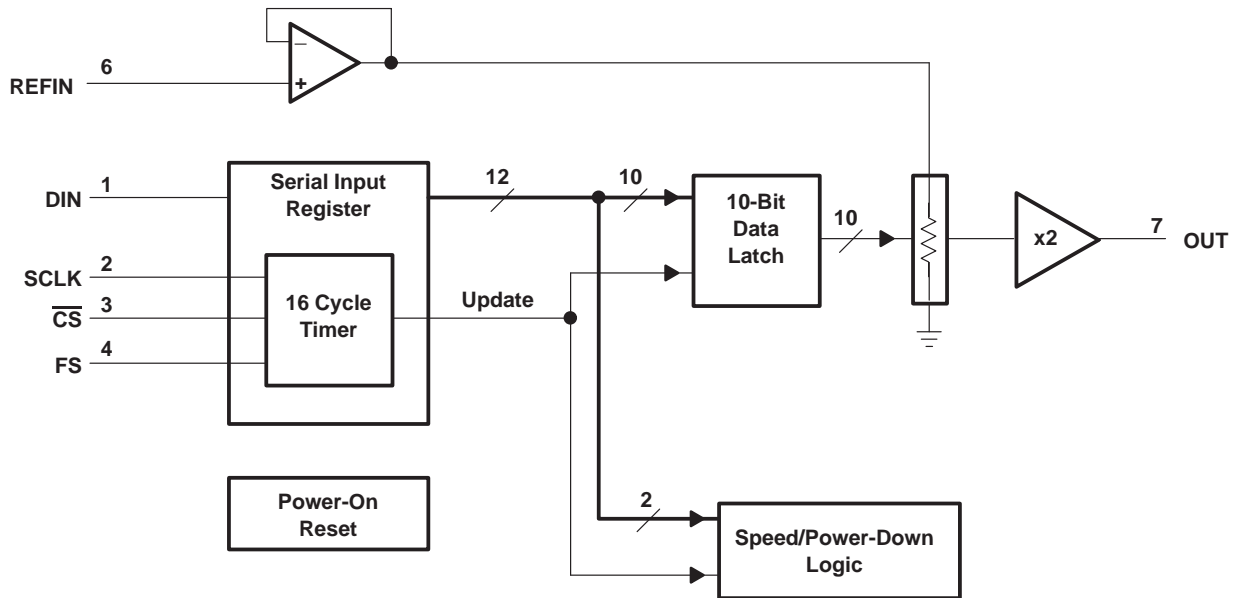

**Terminal Functions**

TERMINAL NAME	NO.	I/O	DESCRIPTION
AGND	5		Analog ground
$\overline{\text{CS}}$	3	I	Chip select. Digital input used to enable and disable inputs, active low.
DIN	1	I	Serial digital data input
FS	4	I	Frame sync. Digital input used for 4-wire serial interfaces such as the TMS320 DSP interface.
OUT	7	O	DAC analog output
REFIN	6	I	Reference analog input voltage
SCLK	2	I	Serial digital clock input
VDD	8		Positive power supply

# TLV5606

## 2.7 V TO 5.5 V LOW POWER 10-BIT DIGITAL-TO-ANALOG CONVERTERS WITH POWER DOWN

SLAS259 – DECEMBER 1999

### absolute maximum ratings over operating free-air temperature range (unless otherwise noted)†

Supply voltage ( $V_{DD}$ to AGND) .....	7 V
Reference input voltage range .....	– 0.3 V to $V_{DD} + 0.3$ V
Digital input voltage range .....	– 0.3 V to $V_{DD} + 0.3$ V
Operating free-air temperature range, $T_A$ : TLV5606C .....	0°C to 70°C
TLV5606I .....	–40°C to 85°C
Storage temperature range, $T_{stg}$ .....	–65°C to 150°C
Lead temperature 1,6 mm (1/16 inch) from case for 10 seconds .....	260°C

† Stresses beyond those listed under “absolute maximum ratings” may cause permanent damage to the device. These are stress ratings only, and functional operation of the device at these or any other conditions beyond those indicated under “recommended operating conditions” is not implied. Exposure to absolute-maximum-rated conditions for extended periods may affect device reliability.

### recommended operating conditions

		MIN	NOM	MAX	UNIT
Supply voltage, $V_{DD}$	$V_{DD} = 5$ V	4.5	5	5.5	V
	$V_{DD} = 3$ V	2.7	3	3.3	V
High-level digital input voltage, $V_{IH}$	$V_{DD} = 2.7$ V to 5.5 V	2			V
Low-level digital input voltage, $V_{IL}$	$V_{DD} = 2.7$ V to 5.5 V			0.8	V
Reference voltage, $V_{ref}$ to REFIN terminal	$V_{DD} = 5$ V (see Note 1)	AGND	2.048	$V_{DD} - 1.5$	V
Reference voltage, $V_{ref}$ to REFIN terminal	$V_{DD} = 3$ V (see Note 1)	AGND	1.024	$V_{DD} - 1.5$	V
Load resistance, $R_L$		2	10		k $\Omega$
Load capacitance, $C_L$				100	pF
Clock frequency, $f_{CLK}$				20	MHz
Operating free-air temperature, $T_A$	TLV5606C	0		70	°C
	TLV5606I	–40		85	°C

NOTE 1: Due to the x2 output buffer, a reference input voltage  $\geq V_{DD}/2$  causes clipping of the transfer function.

### electrical characteristics over recommended operating free-air temperature range (unless otherwise noted)

#### power supply

PARAMETER		TEST CONDITIONS		MIN	TYP	MAX	UNIT
$I_{DD}$	Power supply current	$V_{DD} = 5$ V, $V_{REF} = 2.048$ V, No load, All inputs = AGND or $V_{DD}$ , DAC latch = 0x800	Fast		0.9	1.35	mA
			Slow		0.4	0.6	mA
		$V_{DD} = 3$ V, $V_{REF} = 1.024$ V No load, All inputs = AGND or $V_{DD}$ , DAC latch = 0x800	Fast		0.7	1.1	mA
			Slow		0.3	0.45	mA
Power down supply current (see Figure 12)					10		nA
PSRR	Power supply rejection ratio	Zero scale	See Note 2		–80		dB
		Full scale	See Note 3		–80		
Power on threshold voltage, POR					2		V

- NOTES: 2. Power supply rejection ratio at zero scale is measured by varying  $V_{DD}$  and is given by:  
 $PSRR = 20 \log [(E_{ZS}(V_{DDmax}) - E_{ZS}(V_{DDmin})) / V_{DDmax}]$
3. Power supply rejection ratio at full scale is measured by varying  $V_{DD}$  and is given by:  
 $PSRR = 20 \log [(E_G(V_{DDmax}) - E_G(V_{DDmin})) / V_{DDmax}]$



**TLV5606**  
**2.7 V TO 5.5 V LOW POWER 10-BIT DIGITAL-TO-ANALOG**  
**CONVERTERS WITH POWER DOWN**

SLAS259 – DECEMBER 1999

**electrical characteristics over recommended operating free-air temperature range (unless otherwise noted) (continued)**

**static DAC specifications  $R_L = 10\text{ k}\Omega$ ,  $C_L = 100\text{ pF}$**

PARAMETER		TEST CONDITIONS	MIN	TYP	MAX	UNIT
Resolution				10	10	bits
INL	Integral nonlinearity	See Note 4		$\pm 0.5$	$\pm 1.5$	LSB
DNL	Differential nonlinearity	See Note 5		$\pm 0.2$	$\pm 1$	LSB
E <sub>ZS</sub>	Zero-scale error (offset error at zero scale)	See Note 6			$\pm 10$	mV
Zero-scale-error temperature coefficient		See Note 7		10		ppm/°C
E <sub>G</sub>	Gain error	See Note 8			$\pm 0.6$	% of FS voltage
Gain-error temperature coefficient		See Note 9		10		ppm/°C

- NOTES: 4. The relative accuracy or integral nonlinearity (INL) sometimes referred to as linearity error, is the maximum deviation of the output from the line between zero and full scale excluding the effects of zero code and full-scale errors.  
5. The differential nonlinearity (DNL) sometimes referred to as differential error, is the difference between the measured and ideal 1 LSB amplitude change of any two adjacent codes. Monotonic means the output voltage changes in the same direction (or remains constant) as a change in the digital input code.  
6. Zero-scale error is the deviation from zero voltage output when the digital input code is zero.  
7. Zero-scale-error temperature coefficient is given by:  $E_{ZS\ TC} = [E_{ZS}(T_{max}) - E_{ZS}(T_{min})]/V_{ref} \times 10^6/(T_{max} - T_{min})$ .  
8. Gain error is the deviation from the ideal output ( $2V_{ref} - 1\text{ LSB}$ ) with an output load of  $10\text{ k}\Omega$  excluding the effects of the zero-error.  
9. Gain temperature coefficient is given by:  $E_{G\ TC} = [E_G(T_{max}) - E_G(T_{min})]/V_{ref} \times 10^6/(T_{max} - T_{min})$ .

**output specifications**

PARAMETER		TEST CONDITIONS	MIN	TYP	MAX	UNIT
V <sub>O</sub>	Voltage output range	$R_L = 10\text{ k}\Omega$	0		$V_{DD} - 0.1$	V
Output load regulation accuracy		$R_L = 2\text{ k}\Omega$ , vs $10\text{ k}\Omega$		0.1	$\pm 0.25$	% of FS voltage

**reference input (REF)**

PARAMETER		TEST CONDITIONS	MIN	TYP	MAX	UNIT
V <sub>I</sub>	Input voltage range		0		$V_{DD} - 1.5$	V
R <sub>I</sub>	Input resistance			10		M $\Omega$
C <sub>I</sub>	Input capacitance			5		pF
Reference input bandwidth		REFIN = $0.2 V_{pp} + 1.024\text{ V dc}$	Slow		525	kHz
			Fast		1.3	MHz
Reference feed through		REFIN = $1 V_{pp}$ at 1 kHz + $1.024\text{ V dc}$ (see Note 10)		-75		dB

NOTE 10: Reference feedthrough is measured at the DAC output with an input code = 0x000.

**digital inputs**

PARAMETER		TEST CONDITIONS	MIN	TYP	MAX	UNIT
I <sub>IH</sub>	High-level digital input current	$V_I = V_{DD}$			$\pm 1$	$\mu\text{A}$
I <sub>IL</sub>	Low-level digital input current	$V_I = 0\text{ V}$			$\pm 1$	$\mu\text{A}$
C <sub>I</sub>	Input capacitance			3		pF



TLV5606  
2.7 V TO 5.5 V LOW POWER 10-BIT DIGITAL-TO-ANALOG  
CONVERTERS WITH POWER DOWN

SLAS259 – DECEMBER 1999

operating characteristics over recommended operating free-air temperature range (unless otherwise noted)

analog output dynamic performance

PARAMETER		TEST CONDITIONS		MIN	TYP	MAX	UNIT
t <sub>s</sub> (FS)	Output settling time, full scale	R <sub>L</sub> = 10 kΩ, See Note 11	C <sub>L</sub> = 100 pF,	Fast	3	5.5	μs
				Slow	9	20	
t <sub>s</sub> (CC)	Output settling time, code to code	R <sub>L</sub> = 10 kΩ, See Note 12	C <sub>L</sub> = 100 pF,	Fast	1		μs
				Slow	2		μs
SR	Slew rate	R <sub>L</sub> = 10 kΩ, See Note 13	C <sub>L</sub> = 100 pF,	Fast	3.6		V/μs
				Slow	0.9		
Glitch energy		Code transition from 0x7FF to 0x800			10		nV-s
S/N	Signal to noise				62		dB
S/(N+D)	Signal to noise + distortion	f <sub>s</sub> = 400 KSPS    f <sub>out</sub> = 1.1 kHz, R <sub>L</sub> = 10 kΩ,    C <sub>L</sub> = 100 pF,			60		dB
THD	Total harmonic distortion	BW = 20 kHz			-61		dB
Spurious free dynamic range					68		dB

- NOTES: 11. Settling time is the time for the output signal to remain within ±0.5 LSB of the final measured value for a digital input code change of 0x080 to 0x3FF or 0x3FF to 0x080. Not tested, ensured by design.  
 12. Settling time is the time for the output signal to remain within ± 0.5 LSB of the final measured value for a digital input code change of one count. Code change from 0x1FF to 0x200. Not tested, ensured by design.  
 13. Slew rate determines the time it takes for a change of the DAC output from 10% to 90% full-scale voltage.

digital input timing requirements

		MIN	NOM	MAX	UNIT
t <sub>su</sub> (CS-FS)	Setup time, $\overline{\text{CS}}$ low before FS↓	10			ns
t <sub>su</sub> (FS-CK)	Setup time, FS low before first negative SCLK edge	8			ns
t <sub>su</sub> (C16-FS)	Setup time, sixteenth negative edge after FS low on which bit D0 is sampled before rising edge of FS	10			ns
t <sub>su</sub> (C16-CS)	Setup time, sixteenth positive SCLK edge (first positive after D0 is sampled) before $\overline{\text{CS}}$ rising edge. If FS is used instead of the sixteenth positive edge to update the DAC, then the setup time is between the FS rising edge and CS rising edge.	10			ns
t <sub>wH</sub>	Pulse duration, SCLK high	25			ns
t <sub>wL</sub>	Pulse duration, SCLK low	25			ns
t <sub>su</sub> (D)	Setup time, data ready before SCLK falling edge	8			ns
t <sub>h</sub> (D)	Hold time, data held valid after SCLK falling edge	5			ns
t <sub>wH</sub> (FS)	Pulse duration, FS high	20			ns



**TLV5606**  
**2.7 V TO 5.5 V LOW POWER 10-BIT DIGITAL-TO-ANALOG**  
**CONVERTERS WITH POWER DOWN**

SLAS259 – DECEMBER 1999

**PARAMETER MEASUREMENT INFORMATION**

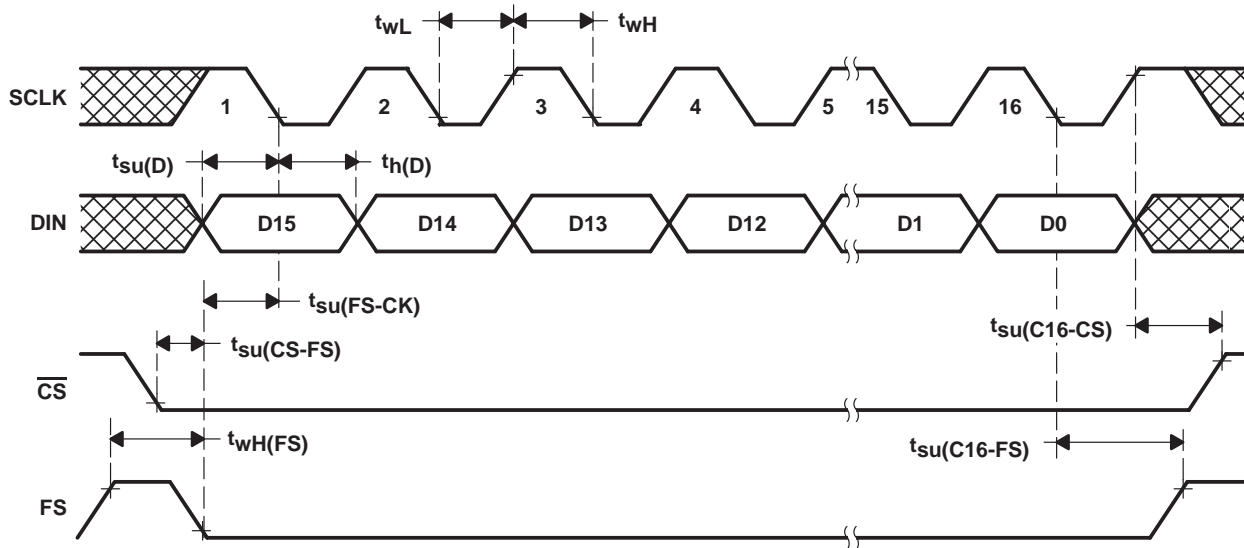

**Figure 1. Timing Diagram**

TYPICAL CHARACTERISTICS

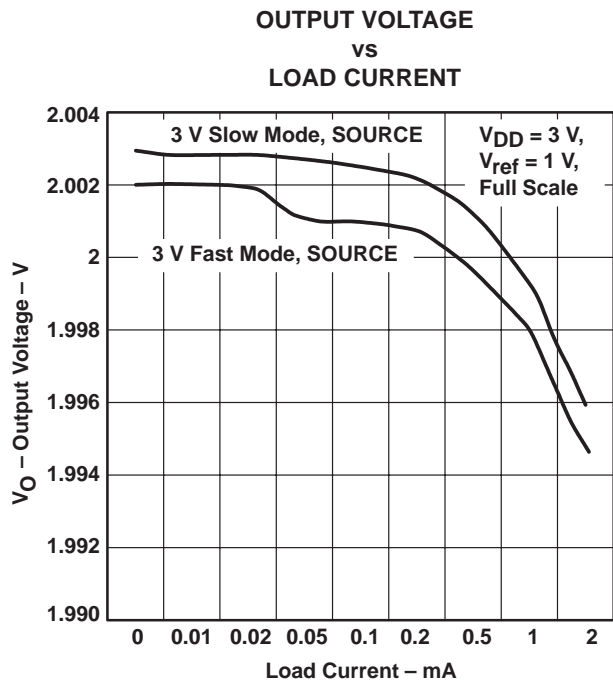

Figure 2

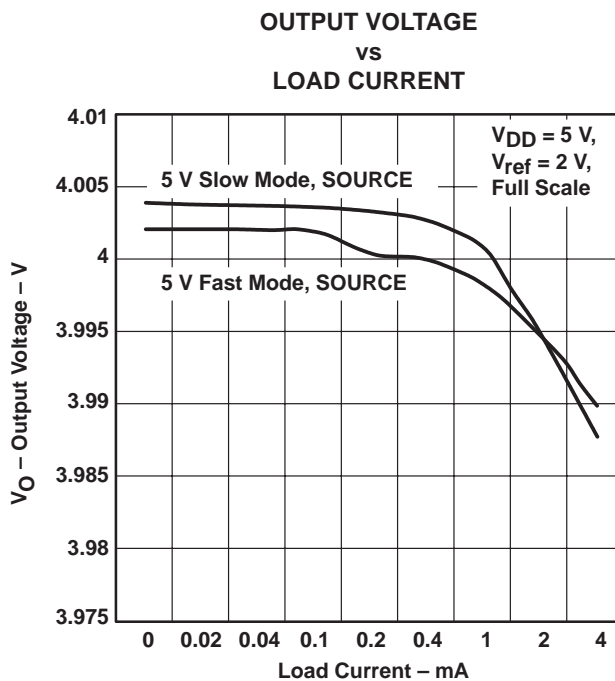

Figure 3

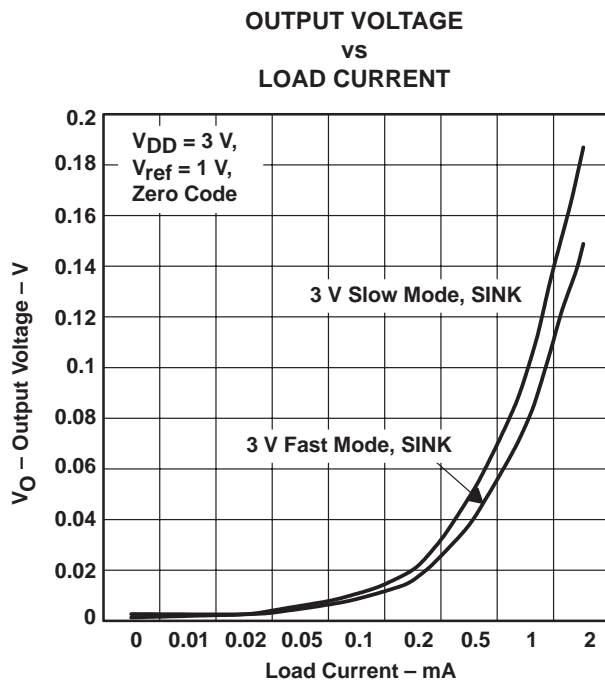

Figure 4

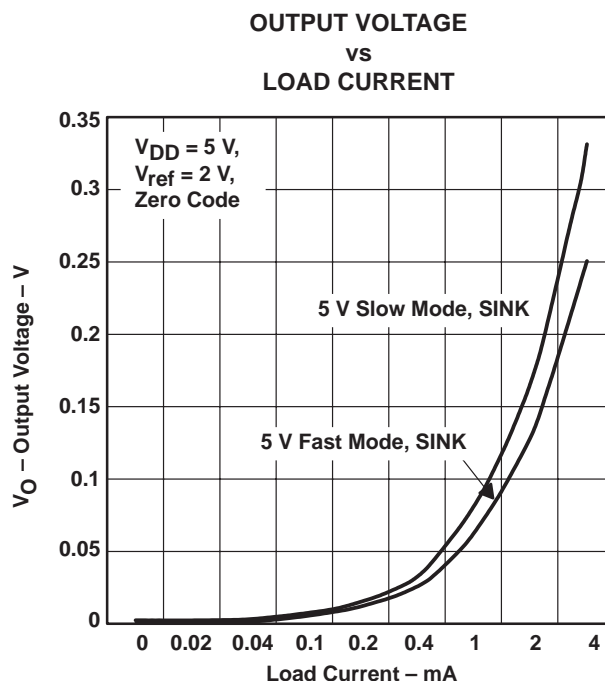
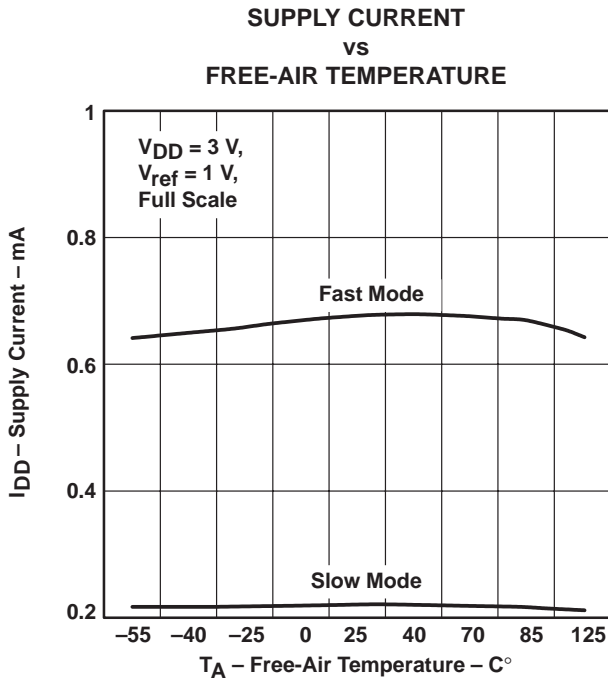

Figure 5

**TLV5606**  
**2.7 V TO 5.5 V LOW POWER 10-BIT DIGITAL-TO-ANALOG**  
**CONVERTERS WITH POWER DOWN**

SLAS259 – DECEMBER 1999

**TYPICAL CHARACTERISTICS**



**Figure 6**

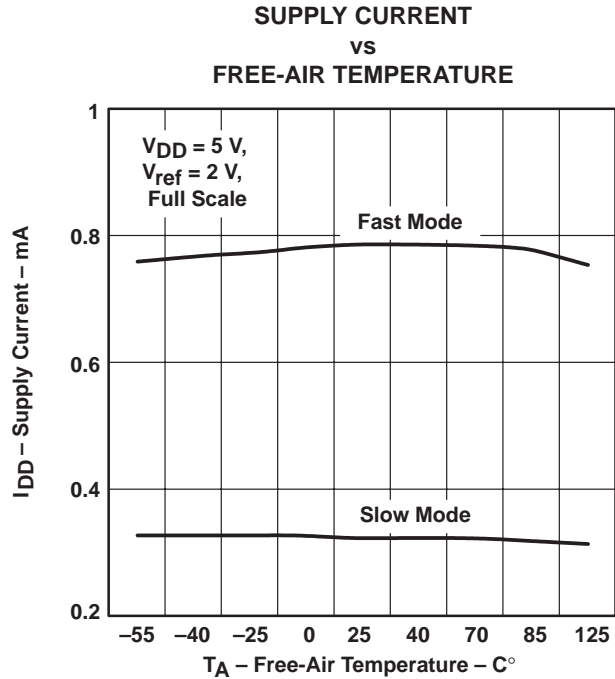

**Figure 7**

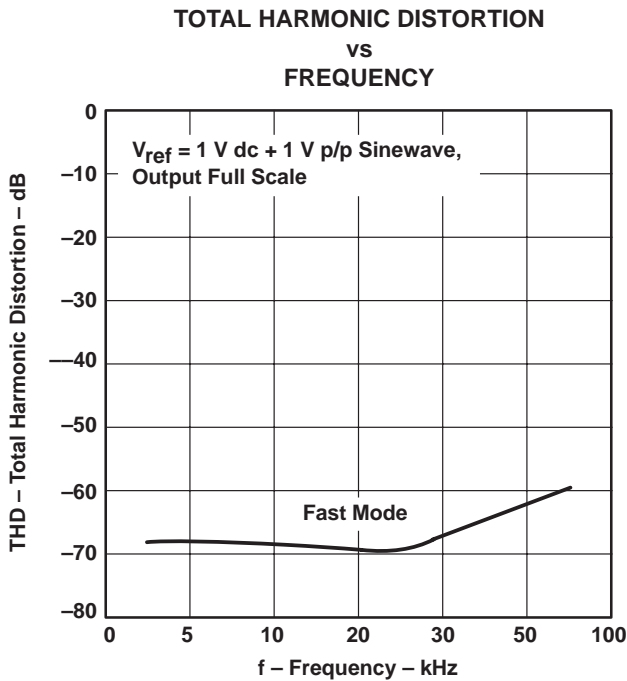

**Figure 8**

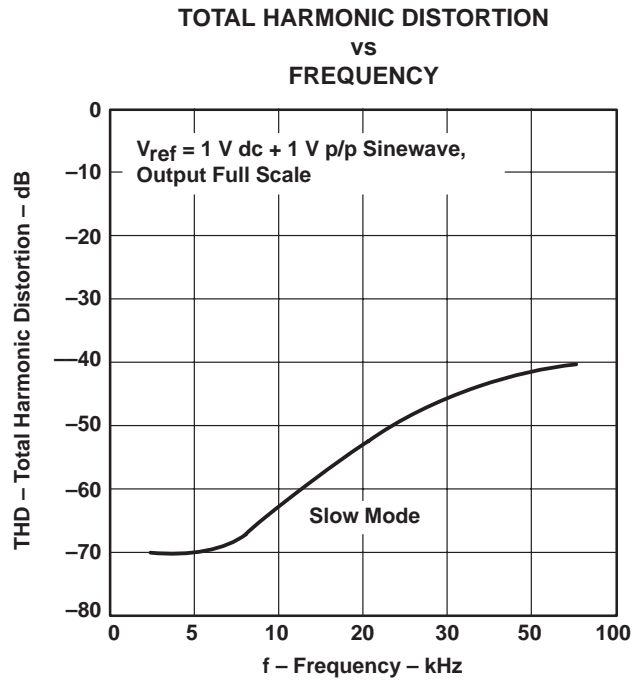
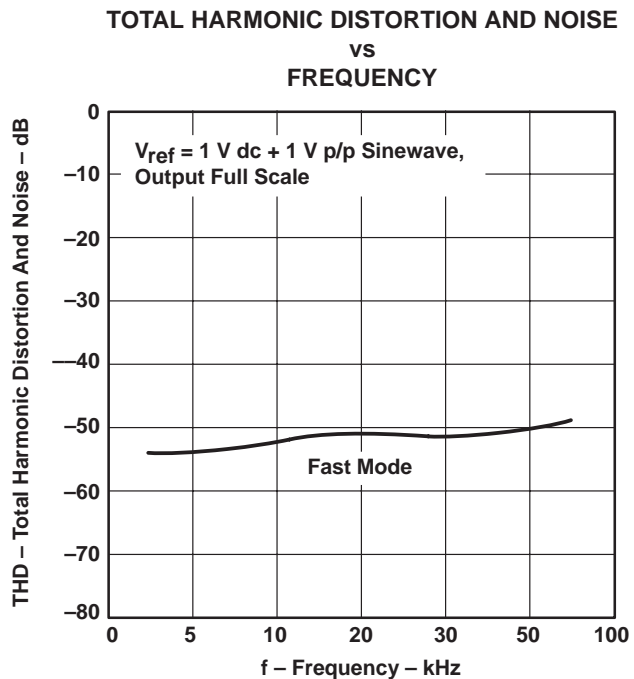

**Figure 9**





**TYPICAL CHARACTERISTICS**



**Figure 10**

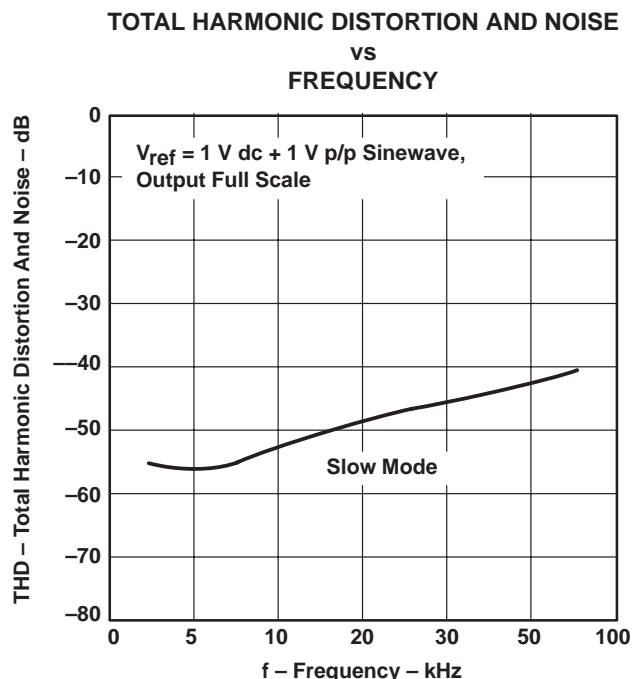

**Figure 11**

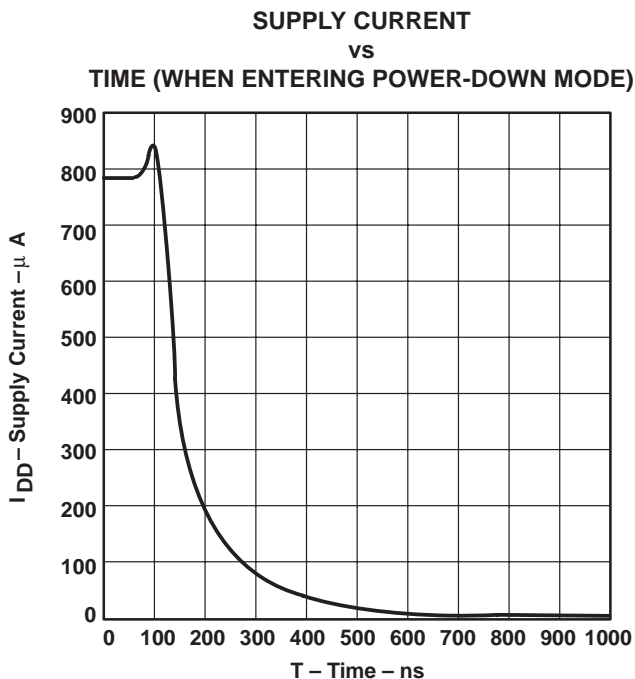

**Figure 12**

TYPICAL CHARACTERISTICS

INTEGRAL NONLINEARITY ERROR

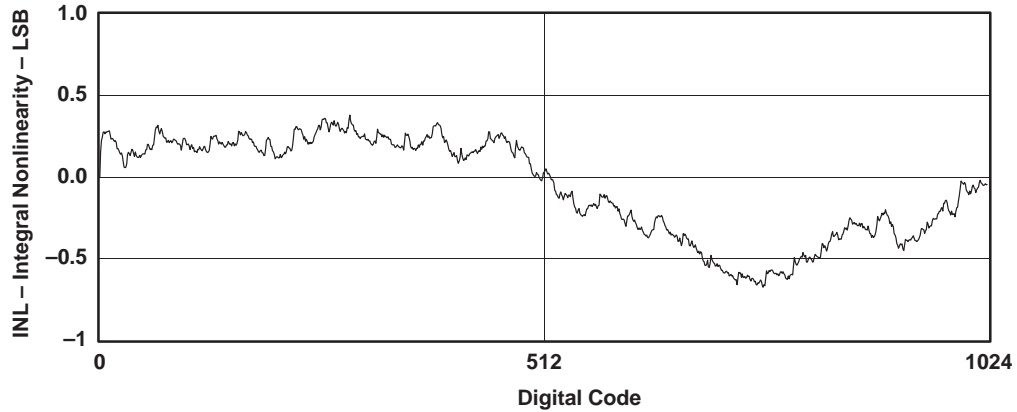

Figure 13

DIFFERENTIAL NONLINEARITY ERROR

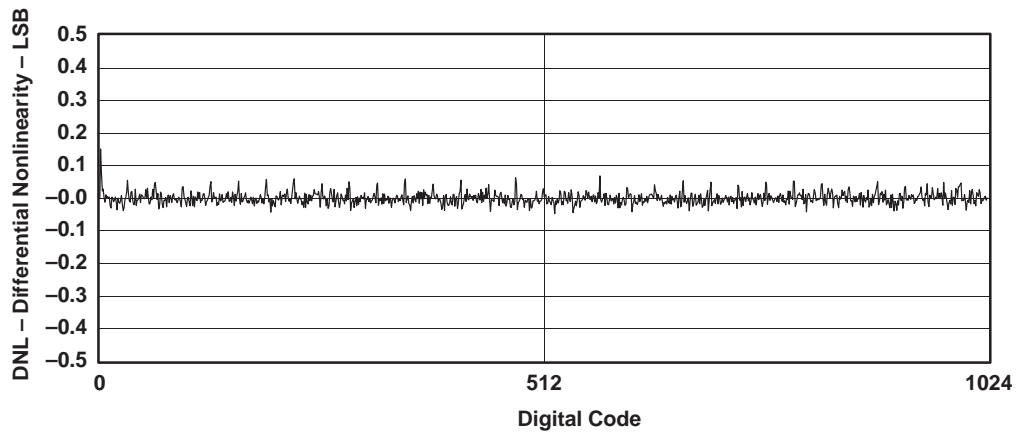

Figure 14

## APPLICATION INFORMATION

### general function

The TLV5606 is a 10-bit single supply DAC based on a resistor string architecture. The device consists of a serial interface, speed and power-down control logic, a reference input buffer, a resistor string, and a rail-to-rail output buffer.

The output voltage (full scale determined by external reference) is given by:

$$2 \text{ REF} \frac{\text{CODE}}{0x1000} \text{ [V]}$$

Where REF is the reference voltage and CODE is the digital input value within the range of 0x000 to 0xFFC. A power-on reset initially resets the internal latches to a defined state (all bits zero).

### serial interface

Explanation of data transfer: First, the device has to be enabled with  $\overline{\text{CS}}$  set to low. Then, a falling edge of FS starts shifting the data bit-per-bit (starting with the MSB) to the internal register on the falling edges of SCLK. After 16 bits have been transferred or FS rises, the content of the shift register is moved to the DAC latch which updates the voltage output to the new level.

The serial interface of the TLV5606 can be used in two basic modes:

- Four wire (with chip select)
- Three wire (without chip select)

Using chip select (four wire mode), it is possible to have more than one device connected to the serial port of the data source (DSP or microcontroller). The interface is compatible with the TMS320 family. Figure 15 shows an example with two TLV5606s connected directly to a TMS320 DSP.

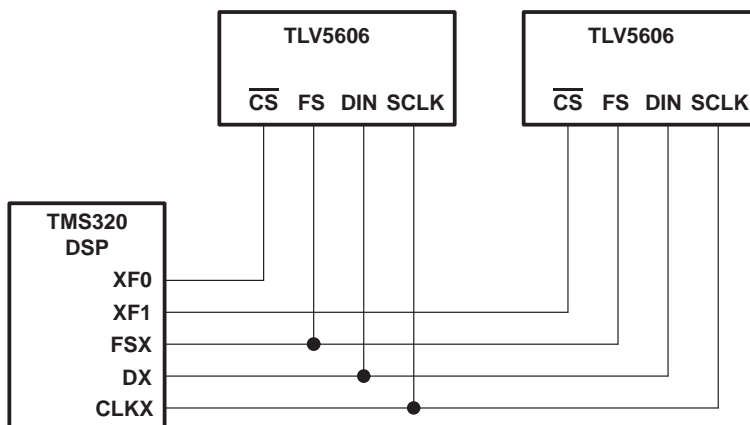

Figure 15. TMS320 Interface

**TLV5606**  
**2.7 V TO 5.5 V LOW POWER 10-BIT DIGITAL-TO-ANALOG**  
**CONVERTERS WITH POWER DOWN**

SLAS259 – DECEMBER 1999

**APPLICATION INFORMATION**

**serial interface (continued)**

If there is no need to have more than one device on the serial bus, then  $\overline{CS}$  can be tied low. Figure 16 shows an example of how to connect the TLV5606 to a TMS320, SPI, or Microwire port using only three pins.

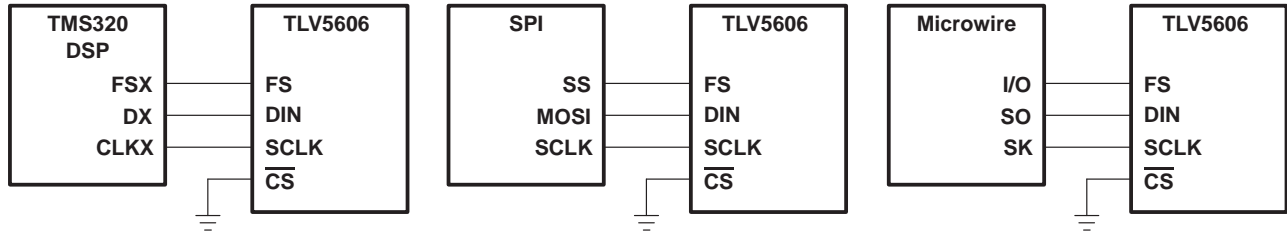

**Figure 16. Three-Wire Interface**

Notes on SPI and Microwire: Before the controller starts the data transfer, the software has to generate a falling edge on the I/O pin connected to FS. If the word width is 8 bits (SPI and Microwire), two write operations must be performed to program the TLV5606. After the write operation(s), the DAC output is updated automatically on the sixteenth positive clock edge.

**serial clock frequency and update rate**

The maximum serial clock frequency is given by:

$$f_{SCLKmax} = \frac{1}{t_{wH(min)} + t_{wL(min)}} = 20 \text{ MHz}$$

The maximum update rate is:

$$f_{UPDATEmax} = \frac{1}{16 (t_{wH(min)} + t_{wL(min)})} = 1.25 \text{ MHz}$$

The maximum update rate is a theoretical value for the serial interface, since the settling time of the TLV5606 has to be considered also.

**data format**

The 16-bit data word for the TLV5606 consists of two parts:

- Control bits (D15 . . . D12)
- New DAC value (D11 . . . D2)

D15	D14	D13	D12	D11	D10	D9	D8	D7	D6	D5	D4	D3	D2	D1	D0
X	SPD	PWR	X	New DAC value (10 bits)										0	0

X: don't care

SPD: Speed control bit. 1 → fast mode 0 → slow mode

PWR: Power control bit. 1 → power down 0 → normal operation

In power-down mode, all amplifiers within the TLV5606 are disabled.



## APPLICATION INFORMATION

### TLV5606 interfaced to TMS320C203 DSP

#### hardware interfacing

Figure 17 shows an example how to connect the TLV5606 to a TMS320C203 DSP. The serial interface of the TLV5606 is ideally suited to this configuration, using a maximum of four wires to make the necessary connections. In applications where only one synchronous serial peripheral is used, the interface can be simplified even further by pulling  $\overline{CS}$  low all the time as shown in the figure.

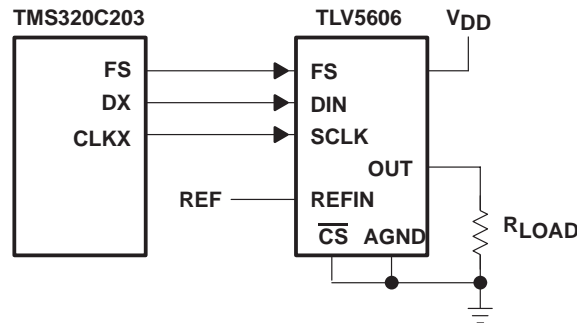

**Figure 17. TLV5606 to DSP Interface**

#### software

No setup procedure is needed to access the TLV5606. The output voltage can be set using just a single command.

```
out    data_addr, SDTR
```

Where `data_addr` points to an address location holding the control bits and the 12 data bits providing the output voltage data. `SDTR` is the address of the transmit FIFO of the synchronous serial port.

The following code shows how to use the timer of the TMS320C203 as a time base to generate a voltage ramp with the TLV5606.

A timer interrupt is generated every 205  $\mu$ s. The corresponding interrupt service routine increments the output code (stored at 0x0064) for the DAC, adds the DAC control bits to the four most significant bits, and writes the new code to the TLV5606. The resulting period of the saw waveform is:

$$\pi = 4096 \times 205 \text{ E-6 s} = 0.84 \text{ s}$$

```

;*****
;* Title   : Ramp generation with TLV5606                                     *
;* Version : 1.0                                                               *
;* DSP     : TI TMS320C203                                                     *
;* © (1998) Texas Instruments Incorporated                                     *
;*****

;----- I/O and memory mapped regs -----
    .include "regs.asm"
;----- vectors -----
    .ps      0h
    b       start
    b       INT1
    b       INT23
    b       TIM_ISR

```

**TLV5606**  
**2.7 V TO 5.5 V LOW POWER 10-BIT DIGITAL-TO-ANALOG**  
**CONVERTERS WITH POWER DOWN**

SLAS259 – DECEMBER 1999

**APPLICATION INFORMATION**

```

;*****
;* Main Program
;*****
        .ps      1000h
        .entry

start:
; disable interrupts
        setc     INTM          ; disable maskable interrupts
        splk    #0ffffh, IFR
        splk    #0004h, IMR

; set up the timer to interrupt ever 205uS
        splk    #0000h, 60h
        splk    #00FFh, 61h
        out     61h, PRD
        out     60h, TIM
        splk    #0c2fh, 62h
        out     62h, TCR

; Configure SSP to use internal clock, internal frame sync and burst mode
        splk    #0CC0Eh, 63h
        out     63h, SSPCR
        splk    #0CC3Eh, 63h
        out     63h, SSPCR

        splk    #0000h, 64h ; set initial DAC value

; enable interrupts
        clrc    INTM          ; enable maskable interrupts

; loop forever!
next:   idle                ;wait for interrupt
        b       next

; all else fails stop here
done:   b       done        ;hang there

;*****
;* Interrupt Service Routines
;*****
INT1:   ret                 ;do nothing and return
INT23:  ret                 ;do nothing and return
TIM_ISR:
        lacl   64h          ; restore counter value to ACC
        add   #4h           ; increment DAC value
        and   #0FFCh       ; mask 4 MSBs
        sacl  64h          ; store 12 bit counter value
        or   #4000h        ; set DAC control bits
        sacl  65h          ; store DAC value
        out   65h, SDTR    ; send data

        clrc  intm         ; re-enable interrupts
        ret

.END

```



**APPLICATION INFORMATION**

**TLV5606 interfaced to MCS51<sup>®</sup> microcontroller**

**hardware interfacing**

Figure 18 shows an example of how to connect the TLV5606 to an MCS51<sup>®</sup> compatible microcontroller. The serial DAC input data and external control signals are sent via I/O port 3 of the controller. The serial data is sent on the RxD line, with the serial clock output on the TxD line. P3.4 and P3.5 are configured as outputs to provide the chip select and frame sync signals for the TLV5606.

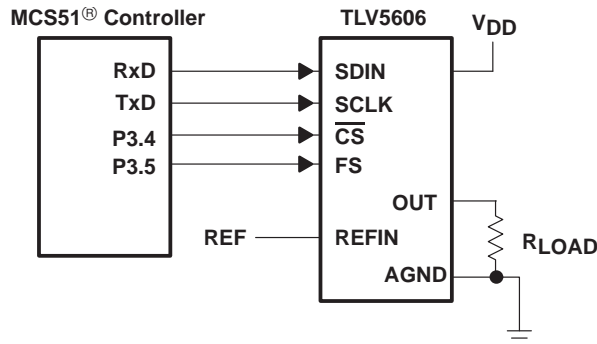

**Figure 18. TLV5606 to MCS51<sup>®</sup> Controller Interface**

**software**

The example program puts out a sine wave on the OUT pin.

The on-chip timer is used to generate interrupts at a fixed frequency. The related interrupt service routine fetches and writes the next sample to the DAC. The samples are stored in a lookup table, which describes one full period of a sine wave.

The serial port of the controller is used in mode 0, which transmits 8 bits of data on RxD, accompanied by a synchronous clock on TxD. Two writes concatenated together are required to write a complete word to the TLV5606. The CS and FS signals are provided in the required fashion through control of I/O port 3, which has bit addressable outputs.

```

;*****
;* Title   : Ramp generation with TLV5606                               *
;* Version : 1.0                                                         *
;* MCU     : INTEL MCS51®                                               *
;* © (1998) Texas Instruments Incorporated                               *
;*****

;-----
; Program function declaration
;-----

NAME    GENSINE

MAIN    SEGMENT                CODE
ISR     SEGMENT                CODE
SINTBL  SEGMENT                CODE
VAR1    SEGMENT                DATA
STACK   SEGMENT                IDATA

;-----
; Code start at address 0, jump to start
;-----

CSEG AT 0
    
```

MCS is a registered trademark of Intel Corporation

# 2.7 V TO 5.5 V LOW POWER 10-BIT DIGITAL-TO-ANALOG CONVERTERS WITH POWER DOWN

SLAS259 – DECEMBER 1999

## APPLICATION INFORMATION

```

LJMP      start      ; Execution starts at address 0 on power-up.
;-----
; Code in the timer0 interrupt vector
;-----
      CSEG AT 0BH
      LJMP      timer0isr ; Jump vector for timer 0 interrupt is 000Bh
;-----
; Define program variables
;-----
      RSEG      VAR1
rolling_ptr: DS 1
;-----
; Interrupt service routine for timer 0 interrupts
;-----
      RSEG      ISR
timer0isr:
      PUSH     PSW
      PUSH     ACC

      CLR      T0          ; set CSB low
      CLR      T1          ; set FS low

      ; The signal to be output on the dac is a sine function. One cycle of a sine wave is
      ; held in a table @ sinevals as 32 samples of msb, lsb pairs (64 bytes). The pointer,
      ; rolling_ptr, rolls round the table of samples incrementing by 2 bytes (1 sample) on
      ; each interrupt (at the end of this routine).

      MOV      DPTR,#sinevals ; set DPTR to the start of the table of sine signal values
      MOV      A,rolling_ptr  ; ACC loaded with the pointer into the sine table

      MOVC     A,@A+DPTR     ; get msb from the table
      ORL      A,#00H        ; set control bits
      MOV      SBUF,A        ; send out msb of data word

      MOVA,rolling_ptr ; move rolling pointer in to ACC
      INC      A             ; increment ACC holding the rolling pointer
      MOVC     A,@A+DPTR     ; which is the lsb of this sample, now in ACC

MSB_TX:
      JNB      TI, MSB_TX    ; wait for transmit to complete
      CLR      TI           ; clear for new transmit
      MOV      SBUF,A        ; and send out the lsb

LSB_TX:
      JNB      TI, LSB_TX    ; wait for lsb transmit to complete
      SETB     T1           ; set FS = 1
      CLR      TI           ; clear for new transmit

      MOV      A,rolling_ptr ; load ACC with rolling pointer
      INC      A             ; increment the ACC twice, to get next sample
      INC      A
      ANL      A,#03FH      ; wrap back round to 0 if >64
      MOV      rolling_ptr,A ; move value held in ACC back to the rolling pointer

      SETB     T0           ; CSB high

      POP      ACC
      POP      PSW

      RETI
;-----
; Set up stack
;-----

```



TLV5606  
2.7 V TO 5.5 V LOW POWER 10-BIT DIGITAL-TO-ANALOG  
CONVERTERS WITH POWER DOWN

SLAS259 – DECEMBER 1999

**APPLICATION INFORMATION**

```
RSEG   STACK
DS     10h           ; 16 Byte Stack!
;-----
; Main Program
;-----

RSEG   MAIN

start:
MOV    SP,#STACK-1  ; first set Stack Pointer

CLR    A
MOV    SCON,A       ; set serial port 0 to mode 0
MOV    TMOD,#02H    ; set timer 0 to mode 2 - auto-reload
MOV    TH0,#0C8H    ; set TH0 for 16.67 kHz interrupts
SETB   T1           ; set FS = 1
SETB   T0           ; set CSB = 1

SETB   ET0         ; enable timer 0 interrupts
SETB   EA          ; enable all interrupts

MOV    rolling_ptr,A ; set rolling pointer to 0
SETB   TR0         ; start timer 0

always:
SJMP   always      ; while(1) !
RET

;-----
; Table of 32 sine wave samples used as DAC data
;-----

RSEG   SINTBL
sinevals:
DW     01000H
DW     0903CH
DW     05094H
DW     0305CH
DW     0B084H
DW     070C8H
DW     0F0E0H
DW     0F066H
DW     0F038H
DW     0F06CH
DW     0F0E0H
DW     070C8H
DW     0B084H
DW     0305CH
DW     05094H
DW     0903CH
DW     01000H
DW     06020H
DW     0A0E8H
DW     0C060H
DW     040F8H
DW     080B4H
DW     0009CH
DW     00050H
DW     00024H
DW     00050H
DW     0009CH
DW     080B4H
DW     040F8H
DW     0C060H
DW     0A0E8H
DW     06020H

END
```



## APPLICATION INFORMATION

### linearity, offset, and gain error using single ended supplies

When an amplifier is operated from a single supply, the voltage offset can still be either positive or negative. With a positive offset, the output voltage changes on the first code change. With a negative offset, the output voltage may not change with the first code, depending on the magnitude of the offset voltage.

The output amplifier attempts to drive the output to a negative voltage. However, because the most negative supply rail is ground, the output cannot drive below ground and clamps the output at 0 V.

The output voltage then remains at zero until the input code value produces a sufficient positive output voltage to overcome the negative offset voltage, resulting in the transfer function shown in Figure 19.

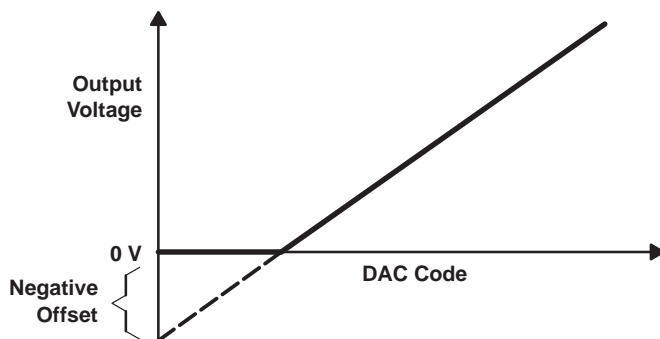

Figure 19. Effect of Negative Offset (Single Supply)

This offset error, not the linearity error, produces this breakpoint. The transfer function would have followed the dotted line if the output buffer could drive below the ground rail.

For a DAC, linearity is measured between zero-input code (all inputs 0) and full-scale code (all inputs 1) after offset and full scale are adjusted out or accounted for in some way. However, single supply operation does not allow for adjustment when the offset is negative due to the breakpoint in the transfer function. So the linearity is measured between full-scale code and the lowest code that produces a positive output voltage.

### power-supply bypassing and ground management

Printed-circuit boards that use separate analog and digital ground planes offer the best system performance. Wire-wrap boards do not perform well and should not be used. The two ground planes should be connected together at the low-impedance power-supply source. The best ground connection may be achieved by connecting the DAC AGND terminal to the system analog ground plane, making sure that analog ground currents are well managed and there are negligible voltage drops across the ground plane.

A 0.1- $\mu$ F ceramic-capacitor bypass should be connected between  $V_{DD}$  and AGND and mounted with short leads as close as possible to the device. Use of ferrite beads may further isolate the system analog supply from the digital power supply.

Figure 20 shows the ground plane layout and bypassing technique.

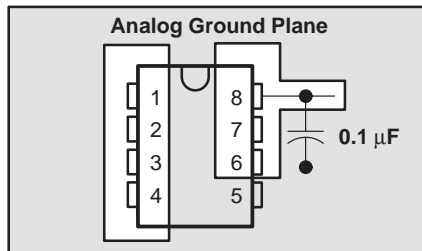

Figure 20. Power-Supply Bypassing

---

## APPLICATION INFORMATION

### definitions of specifications and terminology

#### integral nonlinearity (INL)

The relative accuracy or integral nonlinearity (INL), sometimes referred to as linearity error, is the maximum deviation of the output from the line between zero and full scale excluding the effects of zero code and full-scale errors.

#### differential nonlinearity (DNL)

The differential nonlinearity (DNL), sometimes referred to as differential error, is the difference between the measured and ideal 1 LSB amplitude change of any two adjacent codes. Monotonic means the output voltage changes in the same direction (or remains constant) as a change in the digital input code.

#### zero-scale error ( $E_{ZS}$ )

Zero-scale error is defined as the deviation of the output from 0 V at a digital input value of 0.

#### gain error ( $E_G$ )

Gain error is the error in slope of the DAC transfer function.

#### signal-to-noise ratio + distortion (S/N+D)

S/N+D is the ratio of the rms value of the output signal to the rms sum of all other spectral components below the Nyquist frequency, including harmonics but excluding dc. The value for S/N+D is expressed in decibels.

#### spurious free dynamic range (SFDR)

SFDR is the difference between the rms value of the output signal and the rms value of the largest spurious signal within a specified bandwidth. The value for SFDR is expressed in decibels.

#### total harmonic distortion (THD)

THD is the ratio of the rms sum of the first six harmonic components to the rms value of the fundamental signal and is expressed in decibels.

**TLV5606**  
**2.7 V TO 5.5 V LOW POWER 10-BIT DIGITAL-TO-ANALOG**  
**CONVERTERS WITH POWER DOWN**

SLAS259 – DECEMBER 1999

**MECHANICAL DATA**

**D (R-PDSO-G\*\*)**

**PLASTIC SMALL-OUTLINE PACKAGE**

14 PIN SHOWN

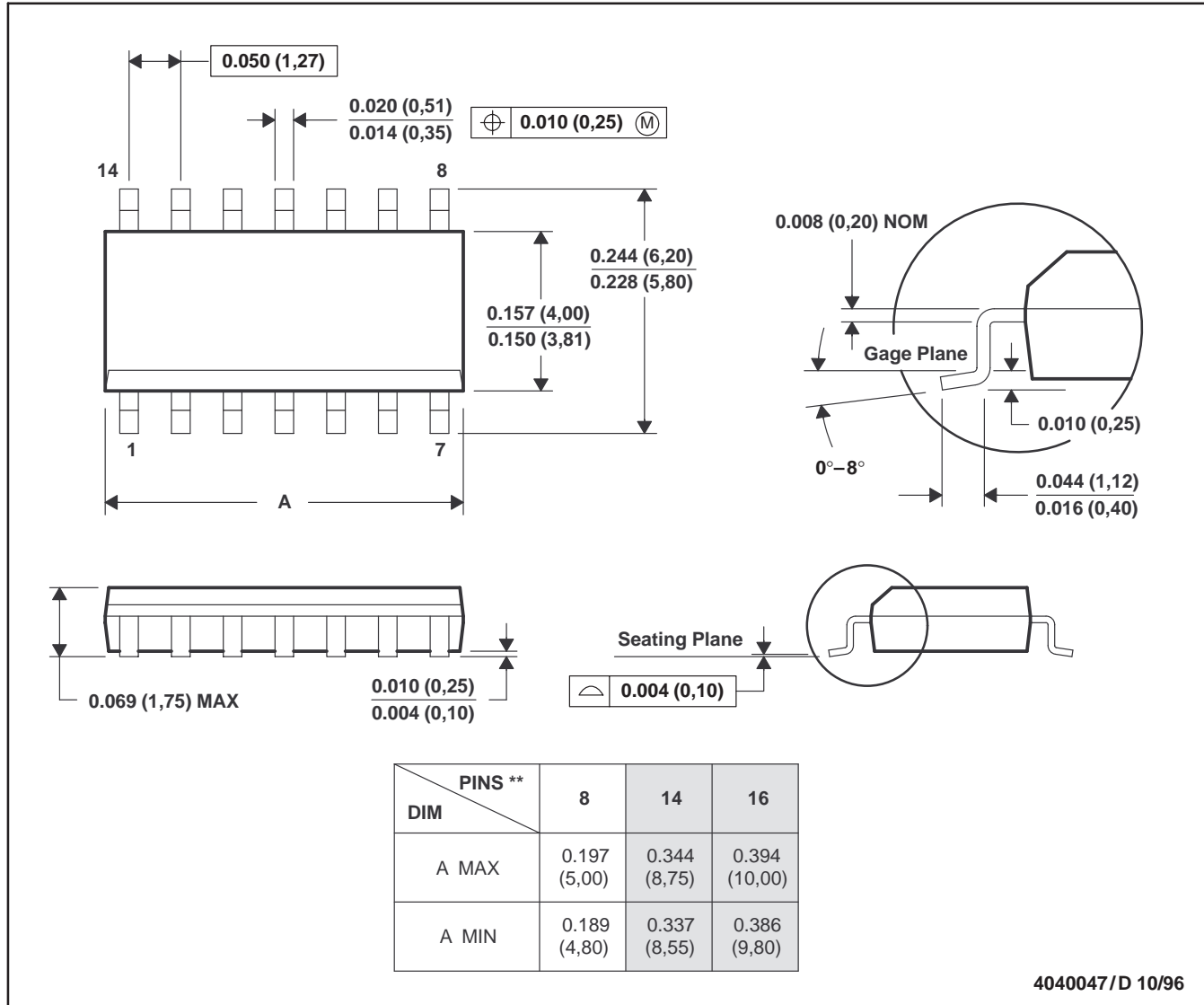

4040047/D 10/96

- NOTES: A. All linear dimensions are in inches (millimeters).  
 B. This drawing is subject to change without notice.  
 C. Body dimensions do not include mold flash or protrusion, not to exceed 0.006 (0,15).  
 D. Falls within JEDEC MS-012

MECHANICAL DATA

DGK (R-PDSO-G8)

PLASTIC SMALL-OUTLINE PACKAGE

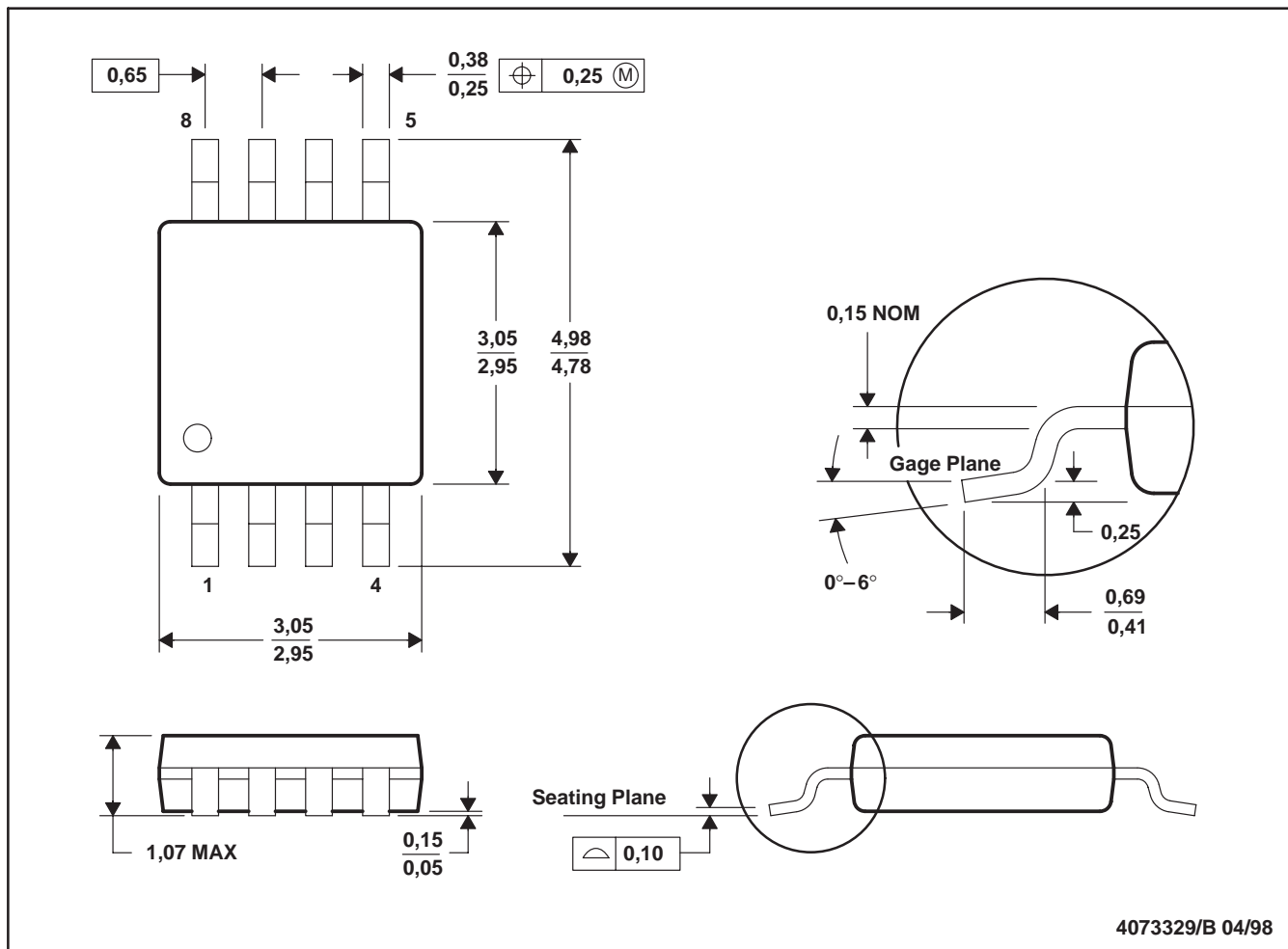

4073329/B 04/98

- NOTES: A. All linear dimensions are in millimeters.  
 B. This drawing is subject to change without notice.  
 C. Body dimensions do not include mold flash or protrusion.  
 D. Falls within JEDEC MO-187

## IMPORTANT NOTICE

Texas Instruments and its subsidiaries (TI) reserve the right to make changes to their products or to discontinue any product or service without notice, and advise customers to obtain the latest version of relevant information to verify, before placing orders, that information being relied on is current and complete. All products are sold subject to the terms and conditions of sale supplied at the time of order acknowledgement, including those pertaining to warranty, patent infringement, and limitation of liability.

TI warrants performance of its semiconductor products to the specifications applicable at the time of sale in accordance with TI's standard warranty. Testing and other quality control techniques are utilized to the extent TI deems necessary to support this warranty. Specific testing of all parameters of each device is not necessarily performed, except those mandated by government requirements.

CERTAIN APPLICATIONS USING SEMICONDUCTOR PRODUCTS MAY INVOLVE POTENTIAL RISKS OF DEATH, PERSONAL INJURY, OR SEVERE PROPERTY OR ENVIRONMENTAL DAMAGE ("CRITICAL APPLICATIONS"). TI SEMICONDUCTOR PRODUCTS ARE NOT DESIGNED, AUTHORIZED, OR WARRANTED TO BE SUITABLE FOR USE IN LIFE-SUPPORT DEVICES OR SYSTEMS OR OTHER CRITICAL APPLICATIONS. INCLUSION OF TI PRODUCTS IN SUCH APPLICATIONS IS UNDERSTOOD TO BE FULLY AT THE CUSTOMER'S RISK.

In order to minimize risks associated with the customer's applications, adequate design and operating safeguards must be provided by the customer to minimize inherent or procedural hazards.

TI assumes no liability for applications assistance or customer product design. TI does not warrant or represent that any license, either express or implied, is granted under any patent right, copyright, mask work right, or other intellectual property right of TI covering or relating to any combination, machine, or process in which such semiconductor products or services might be or are used. TI's publication of information regarding any third party's products or services does not constitute TI's approval, warranty or endorsement thereof.