

- **Advanced LinCMOS™ Silicon-Gate Technology**
- **Easily interfaced to Microprocessors**
- **On-Chip Data Latches**
- **Monotonicity Over Entire A/D Conversion Range**
- **Segmented High-Order Bits Ensure Low-Glitch Output**
- **Designed to Be interchangeable With Analog Devices AD7524, PMI PM-7524, and Micro Power Systems MP7524**
- **Fast Control Signaling for Digital Signal Processor Applications Including Interface With SMJ320**

KEY PERFORMANCE SPECIFICATIONS	
Resolution	8 Bits
Linearity error	1/2 LSB Max
Power dissipation at $V_{DD} = 5\text{ V}$	5 mW Max
Settling time	100 ns Max
Propagation delay	80 ns Max

### description

The AD7524M is an Advanced LinCMOS™ 8-bit digital-to-analog converter (DAC) designed for easy interface to most popular microprocessors.

The AD7524M is an 8-bit multiplying DAC with input latches and with a load cycle similar to the write cycle of a random access memory. Segmenting the high-order bits minimizes glitches during changes in the most-significant bits, which produce the highest glitch impulse. The AD7524M provides accuracy to 1/2 LSB without the need for thin-film resistors or laser trimming, while dissipating less than 5 mW typically.

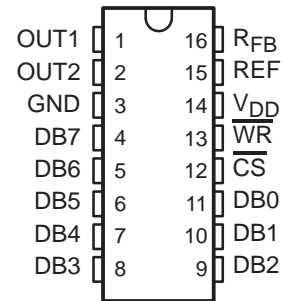
Featuring operation from a 5-V to 15-V single supply, the AD7524M interfaces easily to most microprocessor buses or output ports. Excellent multiplying (2 or 4 quadrant) makes the AD7524M an ideal choice for many microprocessor-controlled gain-setting and signal-control applications.

The AD7524M is characterized for operation from  $-55^{\circ}\text{C}$  to  $125^{\circ}\text{C}$ .

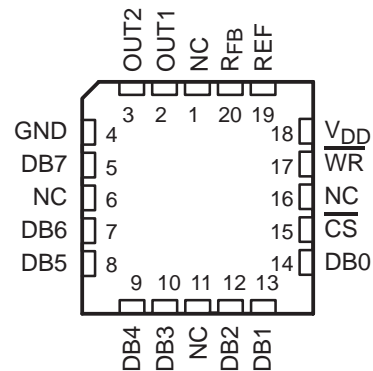
#### AVAILABLE OPTIONS

$T_A$	PACKAGE	
	CERAMIC CHIP CARRIER (FK)	CERAMIC DIP (J)
$-55^{\circ}\text{C}$ to $125^{\circ}\text{C}$	AD7524MFK	AD7524MJ

**J PACKAGE**  
(TOP VIEW)



**FK PACKAGE**  
(TOP VIEW)



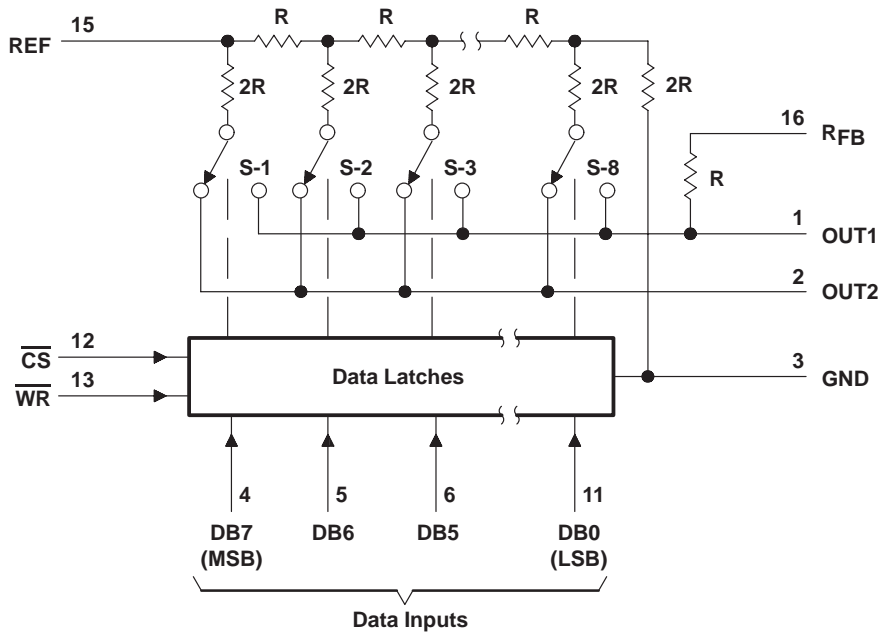
NC—No internal connection

# AD7524M

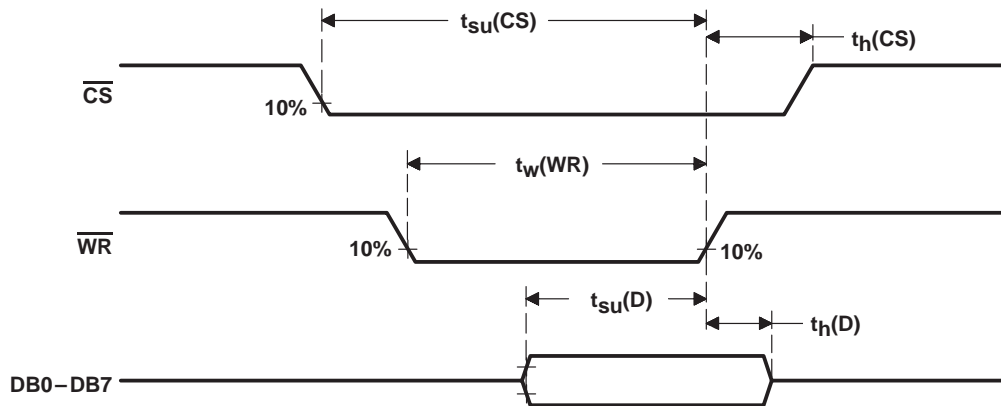
## Advanced LinCMOS™ 8-BIT MULTIPLYING DIGITAL-TO-ANALOG CONVERTER

SGLS028A – SEPTEMBER 1989 – REVISED MARCH 1995

### functional block diagram



### operating sequence



**absolute maximum ratings over operating free-air temperature range (unless otherwise noted)†**

Supply voltage range, $V_{DD}$ .....	–0.3 V to 17 V
Voltage between $R_{FB}$ and GND .....	$\pm 25$ V
Digital input voltage range, $V_I$ .....	–0.3 V to $V_{DD}+0.3$ V
Reference voltage range, $V_{ref}$ .....	$\pm 25$ V
Peak digital input current, $I_I$ .....	10 $\mu$ A
Operating free-air temperature range, $T_A$ .....	–55°C to 125°C
Storage temperature range, $T_{stg}$ .....	–65°C to 150°C
Case temperature for 60 seconds, $T_C$ : FK package .....	260°C
Lead temperature 1,6 mm (1/16 inch) from case for 60 seconds: J package .....	300°C

† Stresses beyond those listed under “absolute maximum ratings” may cause permanent damage to the device. These are stress ratings only, and functional operation of the device at these or any other conditions beyond those indicated under “recommended operating conditions” is not implied. Exposure to absolute-maximum-rated conditions for extended periods may affect device reliability.

**recommended operating conditions**

	$V_{DD} = 5$ V			$V_{DD} = 15$ V			UNIT
	MIN	NOM	MAX	MIN	NOM	MAX	
Supply voltage, $V_{DD}$	4.75	5	5.25	14.5	15	15.5	V
Reference voltage, $V_{ref}$	$\pm 10$			$\pm 10$			V
High-level input voltage, $V_{IH}$	2.4			13.5			V
Low-level input voltage, $V_{IL}$	0.8			1.5			V
$\overline{CS}$ setup time, $t_{su}(CS)$	40			40			ns
$\overline{CS}$ hold time, $t_h(CS)$	0			0			ns
Data bus input setup time, $t_{su}(D)$	25			25			ns
Data bus input hold time, $t_h(D)$	10			10			ns
Pulse duration, $\overline{WR}$ low, $t_w(WR)$	40			40			ns
Operating free-air temperature, $T_A$	–55		125	–55		125	°C

**AD7524M**  
**Advanced LinCMOS™ 8-BIT MULTIPLYING**  
**DIGITAL-TO-ANALOG CONVERTER**

SGLS028A – SEPTEMBER 1989 – REVISED MARCH 1995

**electrical characteristics over recommended operating free-air temperature range,  $V_{ref} = 10\text{ V}$ , OUT1 and OUT2 at GND (unless otherwise noted)**

PARAMETER		TEST CONDITIONS		$V_{DD} = 5\text{ V}$			$V_{DD} = 15\text{ V}$			UNIT	
				MIN	TYP	MAX	MIN	TYP	MAX		
$I_{IH}$	High-level input current	$V_I = V_{DD}$	Full-range	10			10			$\mu\text{A}$	
			25°C	1			1				
$I_{IL}$	Low-level input current	$V_I = 0$	Full-range	-10			-10			$\mu\text{A}$	
			25°C	-1			-1				
$I_{pkg}$	Output leakage current	OUT1	DB0–DB7 at 0, $\overline{WR}$ and $\overline{CS}$ at 0 V	Full-range	$\pm 400$			$\pm 200$			nA
			$V_{ref} = \pm 10\text{ V}$	25°C	$\pm 50$			$\pm 50$			
	OUT2	DB0–DB7 at $V_{DD}$ , $\overline{WR}$ and $\overline{CS}$ at 0	Full-range	$\pm 400$			$\pm 200$				
		$V_{ref} = \pm 10\text{ V}$	25°C	$\pm 50$			$\pm 50$				
$I_{DD}$	Supply current	Quiescent	DB0–DB7 at $V_{IHmin}$ or $V_{ILmax}$		2			2			mA
		Standby	DB0–DB7 at 0 V or $V_{DD}$	Full-range	500			500			$\mu\text{A}$
25°C	100			100							
$k_{SVS}$	Supply voltage sensitivity, $\Delta\text{gain}/\Delta V_{DD}$	$\Delta V_{DD} = 10\%$	Full-range	0.16			0.04			%/%	
			25°C	0.002	0.02	0.001			0.02	pF	
$C_i$	Input capacitance, DB0–DB7, $\overline{WR}$ , $\overline{CS}$	$V_I = 0$	5			5			pF		
$C_o$	Output capacitance	OUT1	DB0–DB7 at 0, $\overline{WR}$ and $\overline{CS}$ at 0 V	30			30			pF	
				OUT2	120			120			
		OUT1	DB0–DB7 at $V_{DD}$ , $\overline{WR}$ and $\overline{CS}$ at 0 V	120			120				
				OUT2	30			30			
Reference input impedance (REF to GND)			5	20	5	20	k $\Omega$				

**operating characteristics over recommended operating free-air temperature range,  $V_{ref} = 10\text{ V}$ , OUT1 and OUT2 at GND (unless otherwise noted)**

PARAMETER	TEST CONDITIONS	$V_{CC} = 5\text{ V}$		$V_{DD} = 15\text{ V}$		UNIT	
		MIN	MAX	MIN	MAX		
Linearity error		$\pm 0.2$		$\pm 0.2$		%FSR	
Gain error	See Note 1	Full range	$\pm 1.4$		$\pm 0.6$		%FSR
		25°C	$\pm 1$		$\pm 0.5$		
Settling time (to 1/2 LSB)	See Note 2	100		100		ns	
Propagation delay from digital input to 90% of final analog output current	See Note 2	80		80		ns	
Feedthrough at OUT1 or OUT2	$V_{ref} = \pm 10\text{ V}$ (100 kHz sinewave), $\overline{WR}$ and $\overline{CS}$ at 0, DB0–DB7 at 0	Full range	0.5		0.5		%FSR
		25°C	0.25		0.25		
Temperature coefficient of gain	$T_A = 25^\circ\text{C}$ to $t_{min}$ or $t_{max}$	$\pm 0.004$		$\pm 0.001$		%FSR/ °C	

NOTES: 1. Gain error is measured using the internal feedback resistor. Nominal Full Scale Range (FSR) =  $V_{ref} - 1\text{ LSB}$ .  
 2. OUT1 load = 100  $\Omega$ ,  $C_{ext} = 13\text{ pF}$ ,  $\overline{WR}$  at 0 V,  $\overline{CS}$  at 0 V, DB0–DB7 at 0 V to  $V_{DD}$  or  $V_{DD}$  to 0 V.



## PRINCIPLES OF OPERATION

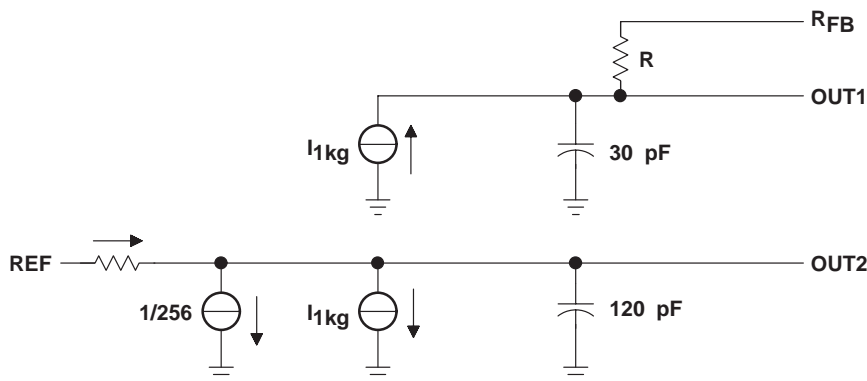
The AD7524M is an 8-bit multiplying D/A converter consisting of an inverted R-2R ladder, analog switches, and data input latches. Binary weighted currents are switched between the OUT1 and OUT2 bus lines, thus maintaining a constant current in each ladder leg independent of the switch state. The high-order bits are decoded and these decoded bits, through a modification in the R-2R ladder, control three equally weighted current sources. Most applications only require the addition of an external operational amplifier and a voltage reference.

The equivalent circuit for all digital inputs low is seen in Figure 1. With all digital inputs low, the entire reference current,  $I_{ref}$ , is switched to OUT2. The current source  $1/256$  represents the constant current flowing through the termination resistor of the R-2R ladder, while the current source  $I_{lkg}$  represents leakage currents to the substrate. The capacitances appearing at OUT1 and OUT2 are dependent upon the digital input code. With all digital inputs high, the off-state switch capacitance (30 pF maximum) appears at OUT2 and the on-state switch capacitance (120 pF maximum) appears at OUT1. With all digital inputs low, the situation is reversed as shown in Figure 1. Analysis of the circuit for all digital inputs high is similar to Figure 1; however, in this case,  $I_{ref}$  would be switched to OUT1.

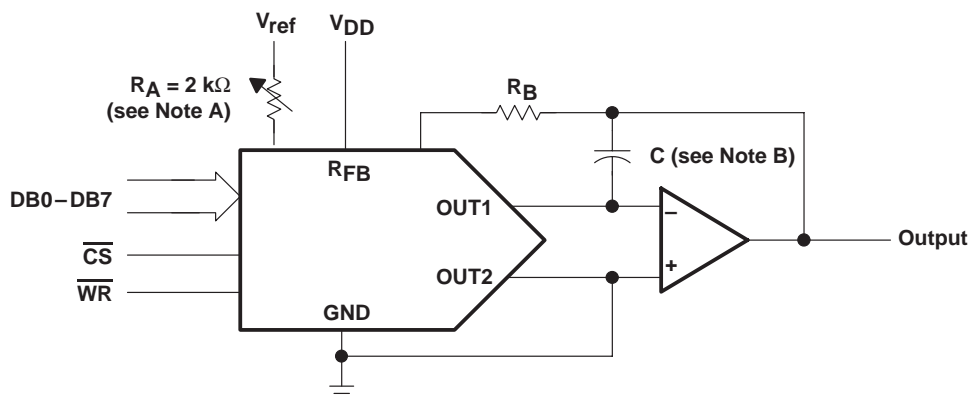
Interfacing the AD7524M D/A converter to a microprocessor is accomplished via the data bus and the  $\overline{CS}$  and  $\overline{WR}$  control signals. When  $\overline{CS}$  and  $\overline{WR}$  are both low, the AD7524M analog output responds to the data activity on the DB0–DB7 data bus inputs. In this mode, the input latches are transparent and input data directly affects the analog output. When either the CS signal or WR signal goes high, the data on the DB0–DB7 inputs are latched until the  $\overline{CS}$  and  $\overline{WR}$  signals go low again. When  $\overline{CS}$  is high, the data inputs are disabled regardless of the state of the  $\overline{WR}$  signal.

The AD7524M is capable of performing 2-quadrant or full 4-quadrant multiplication. Circuit configurations for 2-quadrant or 4-quadrant multiplication are shown in Figures 2 and 3. Input coding for unipolar and bipolar operation are summarized in Tables 1 and 2, respectively.

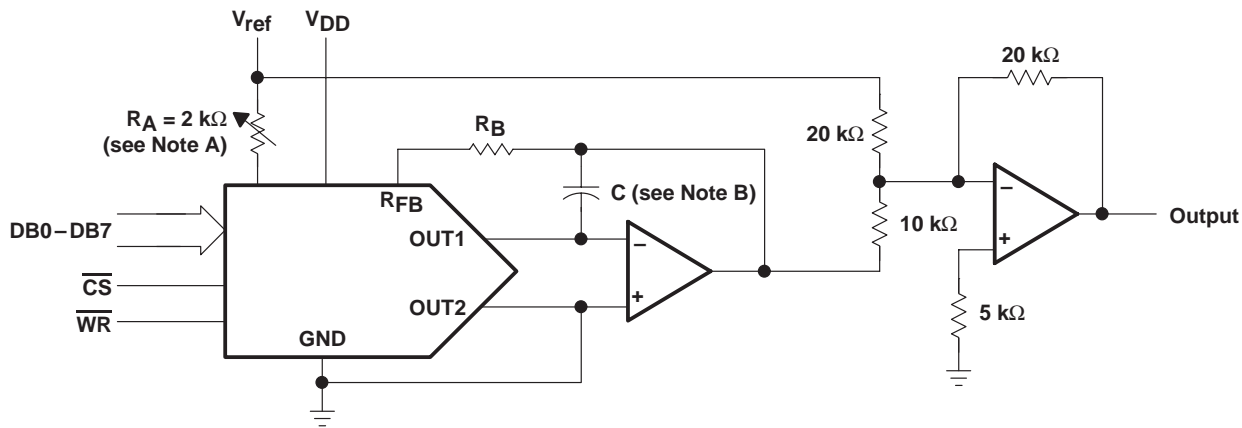
**PRINCIPLES OF OPERATION**



**Figure 1. AD7524M Equivalent Circuit With All Digital Inputs Low**



**Figure 2. Unipolar Operation (2-Quadrant Multiplication)**



**Figure 3. Bipolar Operation (4-Quadrant Operation)**

NOTES: A.  $R_A$  and  $R_B$  used only if gain adjustment is required.  
 B. C phase compensation (10 – 15 pF) is required when using high-speed amplifiers to prevent ringing or oscillation.

## PRINCIPLES OF OPERATION

**Table 1. Unipolar Binary Code**

DIGITAL INPUT (see NOTE 3)		ANALOG OUTPUT
MSB	LSB	
11111111		$-V_{ref} (255/256)$
10000001		$-V_{ref} (129/256)$
10000000		$-V_{ref} (128/256) = -V_{ref} / 2$
01111111		$-V_{ref} (127/256)$
00000001		$-V_{ref} (1/256)$
00000000		0

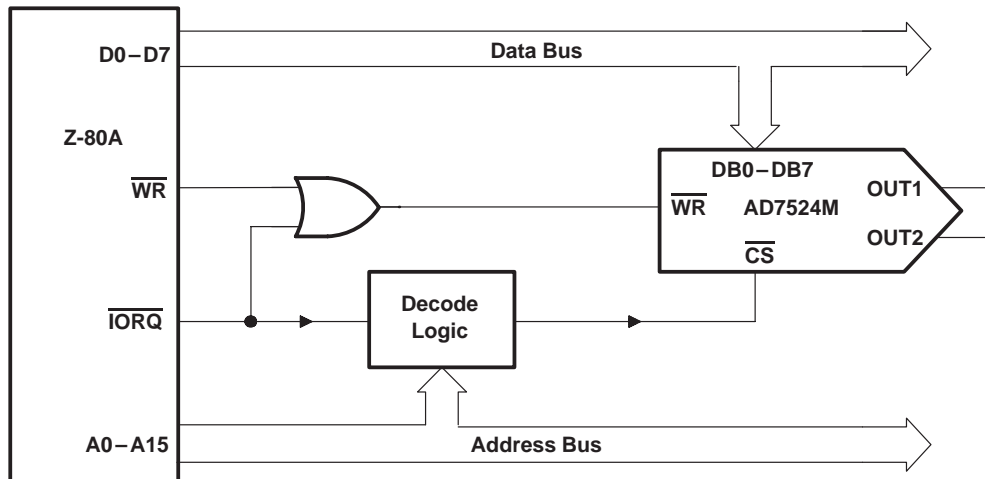
NOTES: 3.  $LSB = 1/256 (V_{ref})$ .

**Table 2. Bipolar (Offset Binary) Code**

DIGITAL INPUT (see NOTE 4)		ANALOG OUTPUT
MSB	LSB	
11111111		$V_{ref} (127/128)$
10000001		$V_{ref} (128)$
10000000		0
01111111		$-V_{ref} (128)$
00000001		$-V_{ref} (127/128)$
00000000		$-V_{ref}$

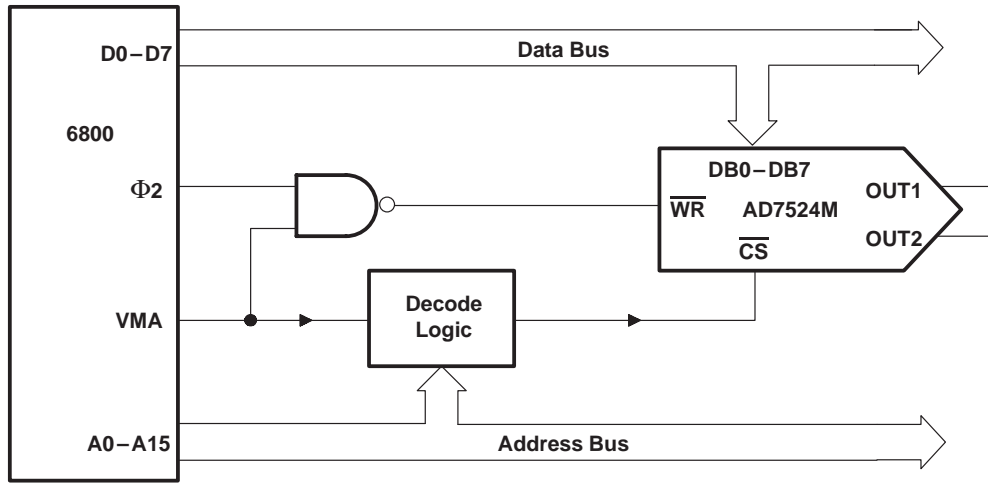
NOTES: 4.  $LSB = 1/128 (V_{ref})$ .

### microprocessor interfaces

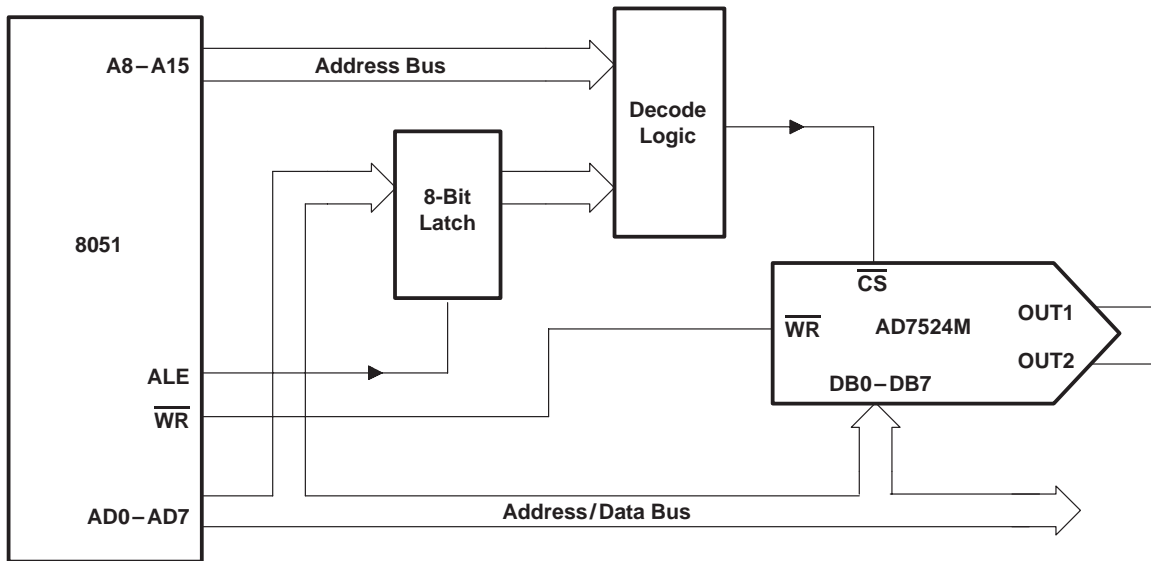


**Figure 4. AD7524M-Z-80A Interface**

**PRINCIPLES OF OPERATION**



**Figure 5. AD7524M-6800 Interface**



**Figure 6. AD7524M-8051 Interface**



## IMPORTANT NOTICE

Texas Instruments and its subsidiaries (TI) reserve the right to make changes to their products or to discontinue any product or service without notice, and advise customers to obtain the latest version of relevant information to verify, before placing orders, that information being relied on is current and complete. All products are sold subject to the terms and conditions of sale supplied at the time of order acknowledgement, including those pertaining to warranty, patent infringement, and limitation of liability.

TI warrants performance of its semiconductor products to the specifications applicable at the time of sale in accordance with TI's standard warranty. Testing and other quality control techniques are utilized to the extent TI deems necessary to support this warranty. Specific testing of all parameters of each device is not necessarily performed, except those mandated by government requirements.

CERTAIN APPLICATIONS USING SEMICONDUCTOR PRODUCTS MAY INVOLVE POTENTIAL RISKS OF DEATH, PERSONAL INJURY, OR SEVERE PROPERTY OR ENVIRONMENTAL DAMAGE ("CRITICAL APPLICATIONS"). TI SEMICONDUCTOR PRODUCTS ARE NOT DESIGNED, AUTHORIZED, OR WARRANTED TO BE SUITABLE FOR USE IN LIFE-SUPPORT DEVICES OR SYSTEMS OR OTHER CRITICAL APPLICATIONS. INCLUSION OF TI PRODUCTS IN SUCH APPLICATIONS IS UNDERSTOOD TO BE FULLY AT THE CUSTOMER'S RISK.

In order to minimize risks associated with the customer's applications, adequate design and operating safeguards must be provided by the customer to minimize inherent or procedural hazards.

TI assumes no liability for applications assistance or customer product design. TI does not warrant or represent that any license, either express or implied, is granted under any patent right, copyright, mask work right, or other intellectual property right of TI covering or relating to any combination, machine, or process in which such semiconductor products or services might be or are used. TI's publication of information regarding any third party's products or services does not constitute TI's approval, warranty or endorsement thereof.