

TP3064B, TP3067B, TP13064B, TP13067B MONOLITHIC SERIAL INTERFACE COMBINED PCM CODEC AND FILTER

SCTS031D – MAY 1990 –REVISED JULY 1996

- **Complete PCM Codec and Filtering Systems Include:**
 - Transmit High-Pass and Low-Pass Filtering
 - Receive Low-Pass Filter With $(\sin x)/x$ Correction
 - Active RC Noise Filters
 - μ -Law or A-Law Compatible Coder and Decoder
 - Internal Precision Voltage Reference
 - Serial I/O Interface
 - Internal Autozero Circuitry
- μ -Law – TP13064B and TP3064B
- A-Law – TP13067B and TP3067B
- ± 5 -V Operation
- Low Operating Power . . . 70 mW Typ
- Power-Down Standby Mode . . . 3 mW Typ
- Automatic Power Down
- TTL- or CMOS-Compatible Digital Interface
- Maximizes Line Interface Card Circuit Density
- Improved Versions of National Semiconductor TP3064, TP3067, TP3064-X, and TP3067-X

description

The TP3064B, TP3067B, TP13064B, and TP13067B each comprise a single-chip pulse-code-modulation encoder and decoder (PCM codec), and PCM line filter. They also provide band-pass filtering of the analog signals prior to the encoding, and low-pass filtering after the decoding of voice signals and call-progress tones. All the functions required to interface a full-duplex (2-wire) voice telephone circuit with a time-division-multiplexed (TDM) system are included on-chip. These devices are pin-for-pin compatible with the National Semiconductor TP3064 and TP3067. Primary applications include:

- Line interface for digital transmission and switching of T1 carrier, PABX (private automated branch exchange), and central office telephone systems
- Subscriber line concentrators
- Digital-encryption systems
- Digital voice-band data-storage systems
- Digital signal processing

These devices are designed to perform the transmit encoding (A/D conversion) and receive decoding (D/A conversion) as well as the transmit and receive filtering functions in a PCM system, and are intended to be used at the analog termination of a PCM line or trunk. They require a transmit master clock and a receive master clock that may be asynchronous (1.536 MHz, 1.544 MHz, or 2.048 MHz), transmit and receive data clocks that are synchronous with the master clock (but can vary from 64 kHz to 2.048 MHz), and transmit and receive frame-sync pulses. The TP3064B and TP13064B contain patented circuitry to achieve low transmit channel idle noise and are not recommended for applications in which the composite signals on the transmit side are below -55 dBm0.

DW OR N PACKAGE
(TOP VIEW)

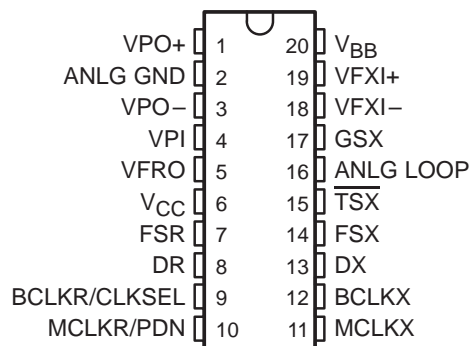

These devices have limited built-in ESD protection. The leads should be shorted together or the device placed in conductive foam during storage or handling to prevent electrostatic damage to the CMOS gates.

PRODUCTION DATA information is current as of publication date. Products conform to specifications per the terms of Texas Instruments standard warranty. Production processing does not necessarily include testing of all parameters.

 **TEXAS
INSTRUMENTS**

POST OFFICE BOX 655303 • DALLAS, TEXAS 75265

Copyright © 1996, Texas Instruments Incorporated

TP3064B, TP3067B, TP13064B, TP13067B MONOLITHIC SERIAL INTERFACE COMBINED PCM CODEC AND FILTER

SCTS031D – MAY 1990 – REVISED JULY 1996

The TP3064B and TP3067B are characterized for operation from 0°C to 70°C. The TP13064B and TP13067B are characterized for operation from -40°C to 85°C.

functional block diagram

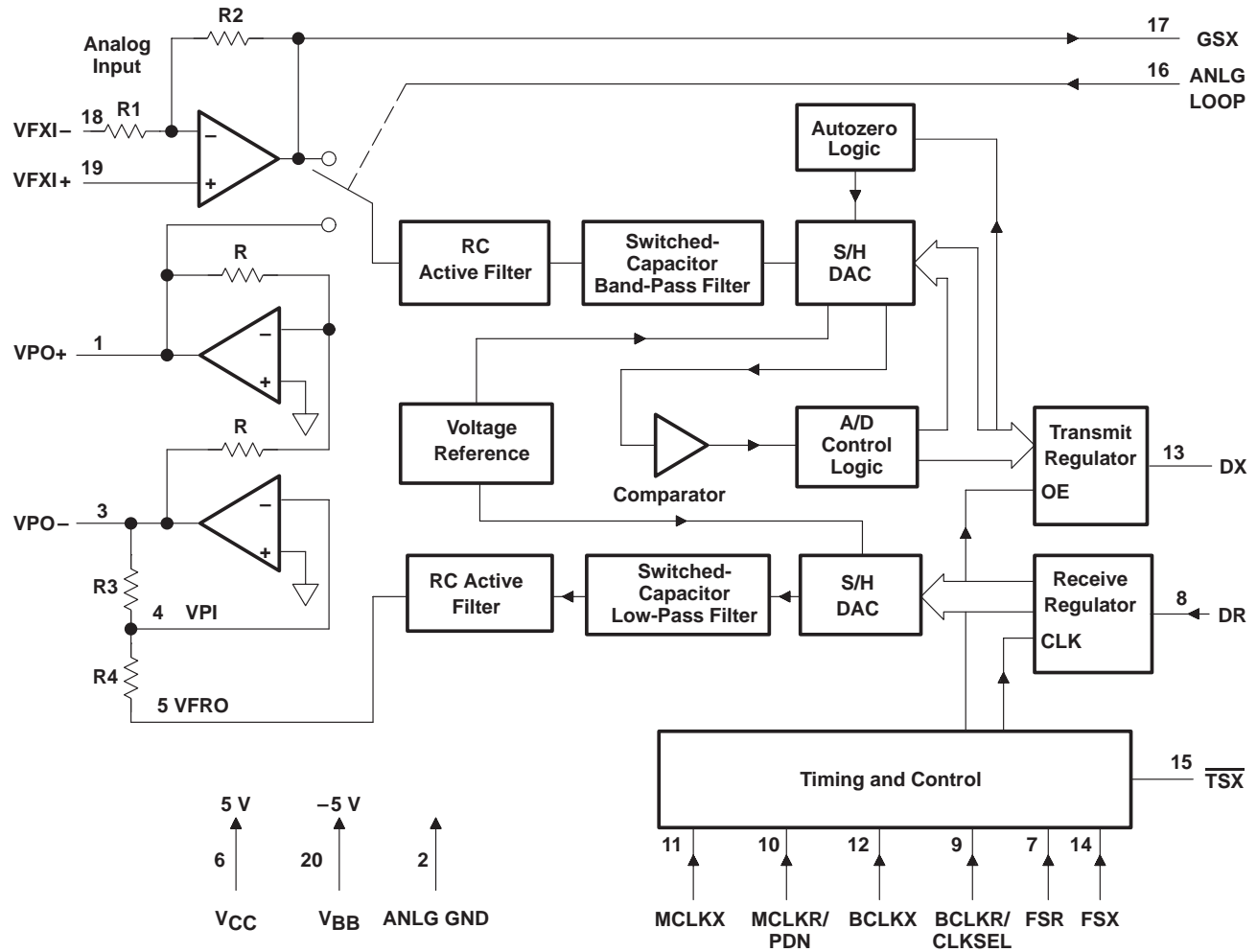

TP3064B, TP3067B, TP13064B, TP13067B
MONOLITHIC SERIAL INTERFACE
COMBINED PCM CODEC AND FILTER

SCTS031D – MAY 1990 –REVISED JULY 1996

Terminal Functions

TERMINAL NAME	NO.	DESCRIPTION
ANLG GND	2	Analog ground. All signals are referenced to ANLG GND.
ANLG LOOP	16	Analog loopback control input. Must be set to logic low for normal operation. When pulled to logic high, the transmit filter input is disconnected from the output of the transmit preamplifier and connected to the VPO+ output of the receive power amplifier.
BCLKR/CLKSEL	9	The bit clock that shifts data into DR after the FSR leading edge. May vary from 64 kHz to 2.048 MHz. Alternately, can be a logic input that selects either 1.536 MHz/1.544 MHz or 2.048 MHz for master clock in synchronous mode. BCLKX is used for both transmit and receive directions (see Table 1).
BCLKX	12	The bit clock that shifts out the PCM data on DX. May vary from 64 kHz to 2.048 MHz, but must be synchronous with MCLKX
DR	8	Receive data input. PCM data is shifted into DR following the FSR leading edge.
DX	13	The 3-state PCM data output that is enabled by FSX
FSR	7	Receive frame-sync pulse input that enables BCLKR to shift PCM data in DR. FSR is an 8-kHz pulse train (see Figures 1 and 2 for timing details).
FSX	14	Transmit frame-sync pulse that enables BCLKX to shift out the PCM data on DX. FSX is an 8-kHz pulse train (see Figures 1 and 2 for timing details).
GSX	17	Analog output of the transmit input amplifier. GSX is used to externally set gain.
MCLKR/PDN	10	Receive master clock (must be 1.536 MHz, 1.544 MHz, or 2.048 MHz). May be synchronous with MCLKX, but should be synchronous for best performance. When MCLKR is connected continuously low, MCLKX is selected for all internal timing. When MCLKR is connected continuously high, the device is powered down.
MCLKX	11	Transmit master clock (must be 1.536 MHz, 1.544 MHz, or 2.048 MHz). May be asynchronous with MCLKR
$\overline{\text{TSX}}$	15	Open-drain output that pulses low during the encoder time slot
V _{BB}	20	Negative power supply. V _{BB} = -5 V ± 5%
V _{CC}	6	Positive power supply. V _{CC} = 5 V ± 5%
VFRO	5	Analog output of the receive filter
VFXI+	19	Noninverting input of the transmit input amplifier
VFXI-	18	Inverting input of the transmit input amplifier
VPI	4	Inverting input to the receive power amplifier. Also powers down both amplifiers when connected to V _{BB} .
VPO+	1	The noninverted output of the receive power amplifier
VPO-	3	The inverted output of the receive power amplifier



TP3064B, TP3067B, TP13064B, TP13067B MONOLITHIC SERIAL INTERFACE COMBINED PCM CODEC AND FILTER

SCTS031D – MAY 1990 – REVISED JULY 1996

absolute maximum ratings over operating free-air temperature range (unless otherwise noted)†

Supply voltage, V_{CC} (see Note 1)	7 V
Supply voltage, V_{BB} (see Note 1)	-7 V
Voltage range at any analog input or output	$V_{CC} + 0.3$ V to $V_{BB} - 0.3$ V
Voltage range at any digital input or output	$V_{CC} + 0.3$ V to GND - 0.3 V
Continuous total dissipation	See Dissipation Rating Table
Operating free-air temperature range: TP3064B, TP3067B	0°C to 70°C
TP13064B, TP13067B	-40°C to 85°C
Storage temperature range	-65°C to 150°C
Lead temperature 1,6 mm (1/16 inch) from case for 10 seconds: DW or N package	260°C

† Stresses beyond those listed under “absolute maximum ratings” may cause permanent damage to the device. These are stress ratings only, and functional operation of the device at these or any other conditions beyond those indicated under “recommended operating conditions” is not implied. Exposure to absolute-maximum-rated conditions for extended periods may affect device reliability.

NOTE 1: All voltages are with respect to GND.

DISSIPATION RATING TABLE

PACKAGE	$T_A \leq 25^\circ\text{C}$ POWER RATING	DERATING FACTOR ABOVE $T_A = 25^\circ\text{C}$	$T_A = 70^\circ\text{C}$ POWER RATING	$T_A = 85^\circ\text{C}$ POWER RATING
DW	1025 mW	8.2 mW/°C	656 mW	533 mW
N	1150 mW	9.2 mW/°C	736 mW	598 mW

recommended operating conditions (see Note 2)

	MIN	NOM	MAX	UNIT
Supply voltage, V_{CC}	4.75	5	5.25	V
Supply voltage, V_{BB}	-4.75	-5	-5.25	V
High-level input voltage, V_{IH}	2.2			V
Low-level input voltage, V_{IL}	0.6			V
Common-mode input voltage range, V_{ICR} †	±2.5			V
Load resistance at GSX, R_L	10			kΩ
Load capacitance at GSX, C_L	50			pF
Operating free-air temperature, T_A	TP3064B, TP3067B		0	°C
	TP13064B, TP13067B		-40	

† Measure with CMRR > 60 dB.

NOTE 2: To avoid possible damage to these CMOS devices and resulting reliability problems, the power-up procedure described in the device power-up sequence paragraphs later in this document should be followed.



TP3064B, TP3067B, TP13064B, TP13067B
MONOLITHIC SERIAL INTERFACE
COMBINED PCM CODEC AND FILTER

SCTS031D – MAY 1990 –REVISED JULY 1996

electrical characteristics over power supply variations and recommended free-air temperature range (unless otherwise noted)

supply current

PARAMETER		TEST CONDITIONS	TP306xB			TP1306xB			UNIT
			MIN	TYP†	MAX	MIN	TYP†	MAX	
I _{CC}	Supply current from V _{CC}	Power down	No load	0.5	1	0.5	1.2	mA	
		Active		6	10	6	11		
I _{BB}	Supply current from V _{BB}	Power down	No load	0.5	1	0.5	1.2	mA	
		Active		6	10	6	11		

† All typical values are at V_{CC} = 5 V, V_{BB} = -5 V, and T_A = 25°C.

electrical characteristics at V_{CC} = 5 V ± 5%, V_{BB} = -5 V ± 5%, GND at 0 V, T_A = 25°C (unless otherwise noted)

digital interface

PARAMETER		TEST CONDITIONS	MIN	MAX	UNIT
V _{OH}	High-level output voltage	DX	I _H = -3.2 mA	2.4	V
V _{OL}	Low-level output voltage	DX	I _L = 3.2 mA	0.4	V
		TSX	I _L = 3.2 mA, Drain open	0.4	
I _{IH}	High-level input current		V _I = V _{IH} to V _{CC}	±10	μA
I _{IL}	Low-level input current	All digital inputs	V _I = GND to V _{IL}	±10	μA
I _{OZ}	Output current in high-impedance state	DX	V _O = GND to V _{CC}	±10	μA

analog interface with transmit amplifier input

PARAMETER		TEST CONDITIONS	MIN	TYP†	MAX	UNIT
I _I	Input current	VFXI+ or VFXI-	V _I = -2.5 V to 2.5 V		±200	nA
r _i	Input resistance	VFXI+ or VFXI-	V _I = -2.5 V to 2.5 V	10		MΩ
r _O	Output resistance		Closed loop, Unit gain	1	3	Ω
	Output dynamic range	GSX	R _L ≥ 10 kΩ		±2.8	V
A _V	Open-loop voltage amplification	VFXI+ to GSX		5000		
B _I	Unity-gain bandwidth	GSX		1	2	MHz
V _{IO}	Input offset voltage	VFXI+ or VFXI-			±20	mV
CMRR	Common-mode rejection ratio			60		dB
kSVR	Supply-voltage rejection ratio			60		dB

† All typical values are at V_{CC} = 5 V, V_{BB} = -5 V, and T_A = 25°C.

analog interface with receive filter

PARAMETER		TEST CONDITIONS	MIN	TYP†	MAX	UNIT
Output resistance	VFRO			1	3	Ω
Load resistance		VFRO = ±2.5 V	600			Ω
Load capacitance	VFRO to GND				500	pF
Output dc offset voltage	VFRO to GND				±200	mV

† All typical values are at V_{CC} = 5 V, V_{BB} = -5 V, and T_A = 25°C.



TP3064B, TP3067B, TP13064B, TP13067B
MONOLITHIC SERIAL INTERFACE
COMBINED PCM CODEC AND FILTER

SCTS031D – MAY 1990 –REVISED JULY 1996

analog interface with power amplifiers

PARAMETER		TEST CONDITIONS	MIN	TYP†	MAX	UNIT
I_I	Input current	$V_{PI} = -1\text{ V to }1\text{ V}$			± 100	nA
r_i	Input resistance	$V_{PI} = -1\text{ V to }1\text{ V}$	10			M Ω
r_o	Output resistance	VPO+ or VPO– Inverting unity gain		1		Ω
A_V	Voltage amplification	VPO– or VPO+ VPO– = 1.77 Vrms, $R_L = 600\ \Omega$		–1		
B_I	Unity-gain bandwidth	VPO– Open loop		400		kHz
V_{IO}	Input offset voltage				± 25	mV
k_{SVR}	Supply-voltage rejection ratio of V_{CC} or V_{BB}	VPO– connected to VPI	0 kHz to 4 kHz	60		dB
			4 kHz to 50 kHz	36		
R_L	Load resistance	Connected from VPO+ to VPO–	600			Ω
C_L	Load capacitance				100	pF

† All typical values are at $V_{CC} = 5\text{ V}$, $V_{BB} = -5\text{ V}$, and $T_A = 25^\circ\text{C}$.

TP3064B, TP3067B, TP13064B, TP13067B
MONOLITHIC SERIAL INTERFACE
COMBINED PCM CODEC AND FILTER

SCTS031D – MAY 1990 –REVISED JULY 1996

timing requirements

PARAMETER		TEST CONDITIONS	MIN	TYP†	MAX	UNIT
f _{clock(M)}	Frequency of master clock	MCLX and MCLKR Depends on the device used and BCLKX/CLKSEL		1.536 1.544 2.048		MHz
f _{clock(B)}	Frequency of bit clock, transmit	BCLKX	64		2.048	MHz
t _{r1}	Rise time of master clock	MCLKX and MCLKR Measured from 20% to 80%			50	ns
t _{f1}	Fall time of master clock	MCLKX and MCLKR Measured from 20% to 80%			50	ns
t _{r2}	Rise time of bit clock, transmit	BCLKX Measured from 20% to 80%			50	ns
t _{f2}	Fall time of bit clock, transmit	BCLKX Measured from 20% to 80%			50	ns
t _{w1}	Pulse duration, MCLKX and MCLKR high		160			ns
t _{w2}	Pulse duration, MCLKX and MCLKR low		160			ns
t _{su1}	Setup time, BCLKX high (and FSX in long-frame sync mode) before MCLKX↓	First bit clock after the leading edge of FSX	100			ns
t _{w3}	Pulse duration, BCLKX and BCLKR high	V _{IH} = 2.2 V	160			ns
t _{w4}	Pulse duration, BCLKX and BCLKR low	V _{IL} = 0.6 V	160			ns
t _{h1}	Hold time, frame sync low after bit clock low (long frame only)		0			ns
t _{h2}	Hold time, BCLKX high after frame sync↑ (short frame only)		0			ns
t _{su2}	Setup time, frame sync high before bit clock↓ (long frame only)		80			ns
t _{d1}	Delay time, BCLKX high to data valid	Load = 150 pF plus 2 LSTTL loads‡	0		140	ns
t _{d2}	Delay time, BCLKX high to $\overline{\text{TSX}}$ low	Load = 150 pF plus 2 LSTTL loads‡			140	ns
t _{d3}	Delay time, BCLKX (or 8 clock FSX in long frame only) low to data output disabled		50		165	ns
t _{d4}	Delay time, FSX or BCLKX high to data valid (long frame only)	C _L = 0 pF to 150 pF	20		165	ns
t _{su3}	Setup time, DR valid before BCLKR↓		50			ns
t _{h3}	Hold time, DR valid after BCLKR or BCLKX↓		50			ns
t _{su4}	Setup time, FSR or FSX high before BCLKR or BCLKX↓	Short-frame sync pulse (1- or 2-bit clock periods long) (see Note 3)	50			ns
t _{h4}	Hold time, FSX or FSR high after BCLKX or BCLKR↓	Short-frame sync pulse (1- or 2-bit clock periods long) (see Note 3)	100			ns
t _{h5}	Hold time, frame sync high after bit clock↓	Long-frame sync pulse (from 3- to 8-bit clock periods long)	100			ns
t _{w5}	Pulse duration of the frame sync pulse (low level)	64 kbps operating mode	160			ns

† All typical values are at V_{CC} = 5 V, V_{BB} = -5 V, and T_A = 25°C.

‡ Nominal input value for an LSTTL load is 18 kΩ.

NOTE 3: For short-frame sync timing, FSR and FSX must go high while their respective bit clocks are high.



TP3064B, TP3067B, TP13064B, TP13067B
MONOLITHIC SERIAL INTERFACE
COMBINED PCM CODEC AND FILTER

SCTS031D – MAY 1990 – REVISED JULY 1996

operating characteristics over operating free-air temperature range, $V_{CC} = 5 V \pm 5\%$, $V_{BB} = -5 V \pm 5\%$, GND at 0 V, $V_I = 1.2276 V$, $f = 1.02 \text{ kHz}$, transmit input amplifier connected for unity gain, noninverting (unless otherwise noted)

filter gains and tracking errors

PARAMETER		TEST CONDITIONS‡	MIN	TYP†	MAX	UNIT
Maximum peak transmit overload level	TP3064B, TP13064B	3.17 dBm0		2.501		V
	TP3067B, TP13067B	3.14 dBm0		2.492		
Transmit filter gain, absolute (at 0 dBm0)		$T_A = 25^\circ\text{C}$	-0.15		0.15	dB
Transmit filter gain, relative to absolute	f = 16 Hz				-40	dB
	f = 50 Hz				-30	
	f = 60 Hz				-26	
	f = 200 Hz		-1.8		-0.1	
	f = 300 Hz to 3000 Hz		-0.15		0.15	
	f = 3300 Hz		-0.35		0.05	
	f = 3400 Hz		-0.8		0	
	f = 4000 Hz				-14	
	f \geq 4600 Hz (measure response from 0 Hz to 4000 Hz)				-32	
Absolute transmit gain variation with temperature and supply voltage		Relative to absolute transmit gain	-0.1		0.1	dB
Transmit gain tracking error with level	Sinusoidal test method; Reference level = -10 dBm0					dB
	3 dBm0 \geq input level \geq -40 dBm0				± 0.2	
	-40 dBm0 > input level \geq -50 dBm0				± 0.4	
	-50 dBm0 > input level \geq -55 dBm0				± 0.8	
Receive filter gain, absolute (at 0 dBm0)		Input is digital code sequence for 0 dBm0 signal, $T_A = 25^\circ\text{C}$	-0.15		0.15	dB
Receive filter gain, relative to absolute	f = 0 Hz to 3000 Hz, $T_A = 25^\circ\text{C}$		-0.15		0.15	dB
	f = 3300 Hz		-0.35		0.05	
	f = 3400 Hz		-0.8		0	
	f = 4000 Hz				-14	
Absolute receive gain variation with temperature and supply voltage		$T_A =$ full range, See Note 4	-0.1		0.1	dB
Receive gain tracking error with level	Sinusoidal test method; reference input PCM code corresponds to an ideally encoded -10 dBm0 signal					dB
	3 dBm0 \geq input level \geq -40 dBm0				± 0.2	
	-40 dBm0 > input level \geq -50 dBm0				± 0.4	
	-50 dBm0 > input level \geq -55 dBm0				± 0.8	
Receive output drive voltage		$R_L = 10 \text{ k}\Omega$			± 2.5	V
Transmit and receive gain tracking error with level (A-law, CCITT C712)	Pseudo-noise test method; reference input PCM code corresponds to an ideally encoded -10 dBm0 signal					dB
	3 dBm0 \geq input level \geq -40 dBm0				± 0.25	
	-40 dBm0 > input level \geq -50 dBm0				± 0.3	
	-50 dBm0 > input level \geq -55 dBm0				± 0.45	

† All typical values are at $V_{CC} = 5 V$, $V_{BB} = -5 V$, and $T_A = 25^\circ\text{C}$.

‡ Absolute rms signal levels are defined as follows: $V_I = 1.2276 V = 0 \text{ dBm0} = 4 \text{ dBm}$ at $f = 1.02 \text{ kHz}$ with $R_L = 600 \Omega$.

NOTE 4: Full range for the TP3064B and TP3067B is 0°C to 70°C . Full range for the TP13064B and TP13067B is -40°C to 85°C .



TP3064B, TP3067B, TP13064B, TP13067B
MONOLITHIC SERIAL INTERFACE
COMBINED PCM CODEC AND FILTER

SCTS031D – MAY 1990 –REVISED JULY 1996

envelope delay distortion with frequency

PARAMETER	TEST CONDITIONS	MIN	TYP†	MAX	UNIT
Transmit delay, absolute (at 0 dBm0)	f = 1600 Hz		290	315	μs
Transmit filter gain, relative to absolute	f = 500 Hz to 600 Hz		195	220	μs
	f = 600 Hz to 800 Hz		120	145	
	f = 800 Hz to 1000 Hz		50	75	
	f = 1000 Hz to 1600 Hz		20	40	
	f = 1600 Hz to 2600 Hz		55	75	
	f = 2600 Hz to 2800 Hz		80	105	
	f = 2800 Hz to 3000 Hz		130	155	
Receive delay, absolute (at 0 dBm0)	f = 1600 Hz		180	200	μs
Receive delay, relative to absolute	f = 500 Hz to 1000 Hz	-40	-25		μs
	f = 1000 Hz to 1600 Hz	-30	-20		
	f = 1600 Hz to 2600 Hz		70	90	
	f = 2600 Hz to 2800 Hz		100	125	
	f = 2800 Hz to 3000 Hz		140	175	

† All typical values are at $V_{CC} = 5\text{ V}$, $V_{BB} = -5\text{ V}$, and $T_A = 25^\circ\text{C}$.

noise

PARAMETER		TEST CONDITIONS	MIN	TYP†	MAX	UNIT
Transmit noise, C-message weighted‡	TP3064B, TP13064B	VFXI = 0 V		5	9	dBmC0
Transmit noise, psophometric weighted (see Note 5)	TP3067B, TP13067B	VFXI = 0 V		-74	-69	dBm0p
Receive noise, C-message weighted	TP3064B, TP13064B	PCM code equals alternating positive and negative zero		2	4	dBmC0
Receive noise, psophometric weighted	TP3067B, TP13067B	PCM code equals positive zero		-86	-83	dBm0p
Noise, single frequency		VFXI+ = 0 V, f = 0 kHz to 100 kHz, Loop-around measurement			-53	dBm0

† All typical values are at $V_{CC} = 5\text{ V}$, $V_{BB} = -5\text{ V}$, and $T_A = 25^\circ\text{C}$.

‡ This parameter is achieved through use of patented circuitry and is not recommended for applications in which the composite signals on the transmit side are below -55 dBm0.

NOTE 5: Measured by extrapolation from the distortion test result



TP3064B, TP3067B, TP13064B, TP13067B
MONOLITHIC SERIAL INTERFACE
COMBINED PCM CODEC AND FILTER

SCTS031D – MAY 1990 –REVISED JULY 1996

power supply rejection

PARAMETER	TEST CONDITIONS		MIN	MAX	UNIT
Positive power-supply rejection, transmit	$V_{CC} = 5\text{ V} + 100\text{ mVrms}$, $V_{FXI+} = -50\text{ dBm0}$	f = 0 Hz to 4 kHz	A-law	38	dB
			μ -law	38	dB \dagger
		f = 4 kHz to 50 kHz		40	dB
Negative power-supply rejection, transmit	$V_{BB} = -5\text{ V} + 100\text{ mVrms}$, $V_{FXI+} = -50\text{ dBm0}$	f = 0 Hz to 4 kHz	A-law	35	dB
			μ -law	35	dB \dagger
		f = 4 kHz to 50 kHz		40	dB
Positive power-supply rejection, receive	PCM code equals positive zero, $V_{CC} = 5\text{ V} + 100\text{ mVrms}$	f = 0 Hz to 4 kHz	A-law	40	dB
			μ -law	40	dB \dagger
		f = 4 kHz to 50 kHz		40	dB
Negative power-supply rejection, receive	PCM code equals positive zero, $V_{BB} = -5\text{ V} + 100\text{ mVrms}$	f = 0 Hz to 4 kHz	A-law	38	dB
			μ -law	38	dB \dagger
		f = 4 kHz to 50 kHz		40	dB
Spurious out-of-band signals at the channel output (VFRO)	0 dBm0, 300-Hz to 3400-Hz input applied to DR (measure individual image signals at VFRO)			-30	dB
	f = 4600 Hz to 7600 Hz			-33	dB
	f = 7600 Hz to 8400 Hz			-40	
	f = 8400 Hz to 100 kHz			-40	

\dagger The unit dBC applies to C-message weighting.

distortion

PARAMETER	TEST CONDITIONS		MIN	MAX	UNIT
Signal-to-distortion ratio, transmit or receive half-channel \ddagger	Level = 3 dBm0			33	dB \dagger
	Level = 0 dBm0 to -30 dBm0			36	
	Level = -40 dBm0	Transmit		29	
		Receive		30	
	Level = -55 dBm0	Transmit		14	
		Receive		15	
Single-frequency distortion products, transmit				-46	dB
Single-frequency distortion products, receive				-46	dB
Intermodulation distortion	Loop-around measurement, $V_{FXI+} = -4\text{ dBm0}$ to -21 dBm0 , Two frequencies in the range of 300 Hz to 3400 Hz			-41	dB
Signal-to-distortion ratio, transmit half-channel (A-law) (CCITT G.714) \S	Level = -3 dBm0			33	dB
	Level = -6 dBm0 to -27 dBm0			36	
	Level = -34 dBm0			33.5	
	Level = -40 dBm0			28.5	
	Level = -55 dBm0			13.5	
Signal-to-distortion ratio, receive half-channel (A-law) (CCITT G.714) \S	Level = -3 dBm0			33	dB
	Level = -6 dBm0 to -27 dBm0			36	
	Level = -34 dBm0			34.2	
	Level = -40 dBm0			30	
	Level = -55 dBm0			15	

\dagger The unit dBC applies to C-message weighting.

\ddagger Sinusoidal test method (see Note 6).

\S Pseudo-noise test method

NOTE 6: The TP13064A and TP3064A are measured using a C-message filter. The TP13067A and TP3067A are measured using a psophometric weighted filter.



POST OFFICE BOX 655303 • DALLAS, TEXAS 75265

TP3064B, TP3067B, TP13064B, TP13067B
MONOLITHIC SERIAL INTERFACE
COMBINED PCM CODEC AND FILTER

SCTS031D – MAY 1990 –REVISED JULY 1996

crosstalk

PARAMETER	TEST CONDITIONS	MIN	TYP†	MAX	UNIT
Crosstalk, transmit to receive	f = 300 Hz to 3000 Hz, DR at steady PCM code	-90		-75	dB
Crosstalk, receive to transmit (see Note 7)	VFXI = 0 V, f = 300 Hz to 3000 Hz	-90		-72	dB

† All typical values are at $V_{CC} = 5\text{ V}$, $V_{BB} = -5\text{ V}$, and $T_A = 25^\circ\text{C}$.

NOTE 7: Receive-to-transmit crosstalk is measured with a -50 dBm0 activation signal applied to VFXI+.

power amplifiers

PARAMETER	TEST CONDITIONS	MIN	MAX	UNIT
Maximum 0 dBm0 rms level for better than $\pm 0.1\text{ dB}$ linearity over the range if -10 dBm0 to 3 dBm0	Balanced load, R_L , connected between VPO+ and VPO-			V_{RMS}
	$R_L = 600\ \Omega$	3.3		
	$R_L = 1200\ \Omega$	3.5		
	$R_L = 30\ \text{k}\Omega$	4		
Signal/distortion	$R_L = 600\ \Omega$	50		dB



TP3064B, TP3067B, TP13064B, TP13067B
 MONOLITHIC SERIAL INTERFACE
 COMBINED PCM CODEC AND FILTER

SCTS031D – MAY 1990 –REVISED JULY 1996

PARAMETER MEASUREMENT INFORMATION

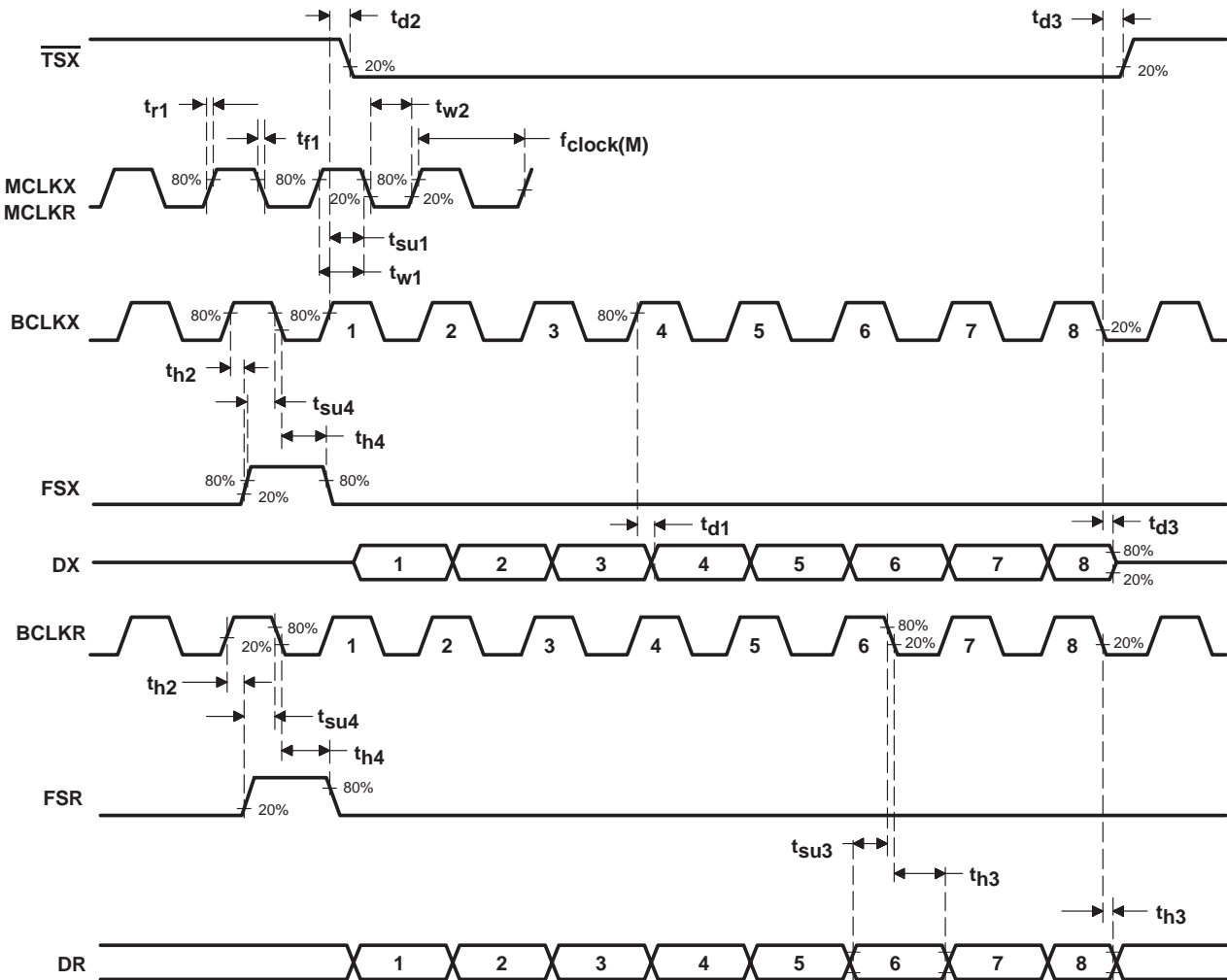

Figure 1. Short-Frame Sync Timing

PARAMETER MEASUREMENT INFORMATION

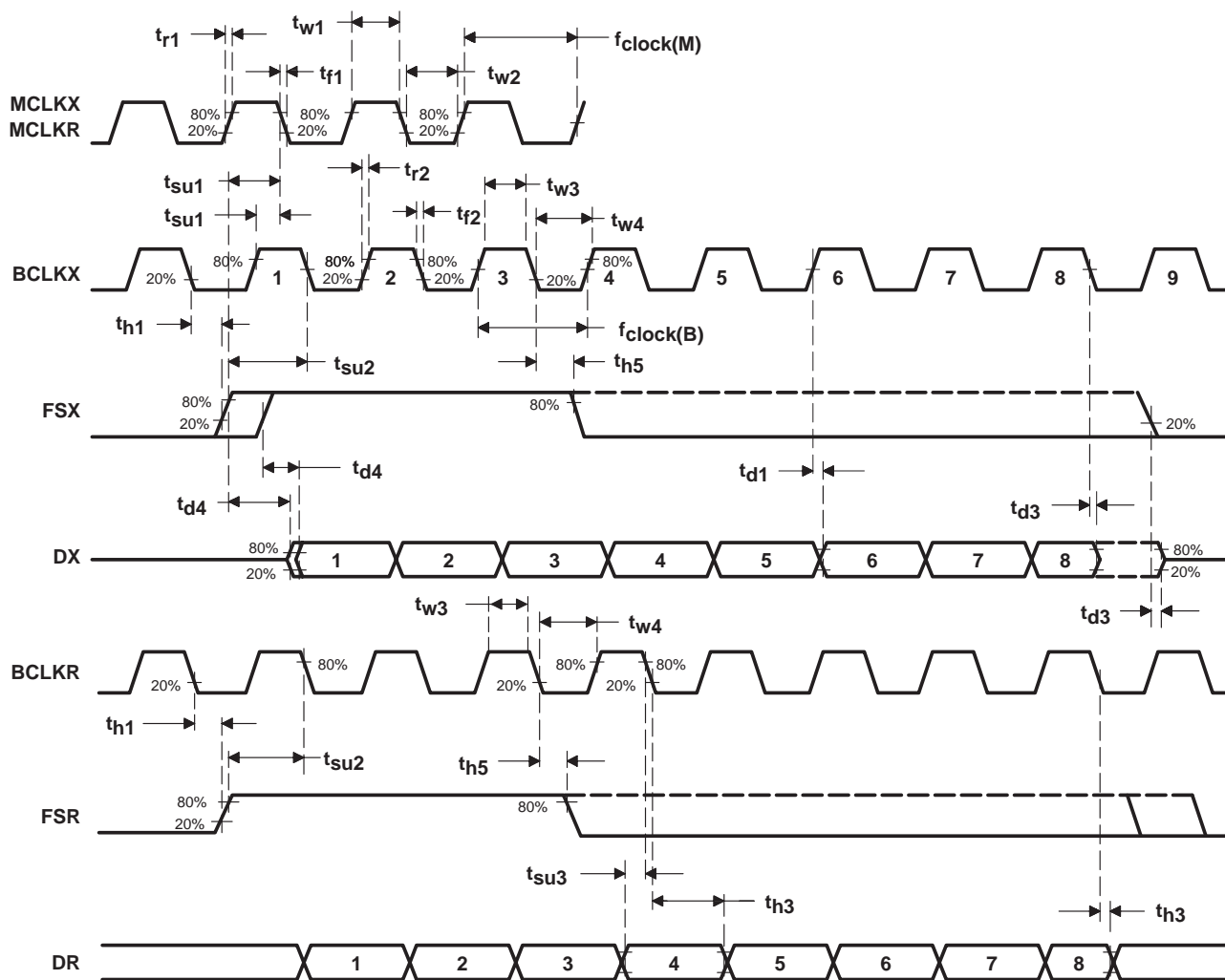

Figure 2. Long-Frame Sync Timing

TP3064B, TP3067B, TP13064B, TP13067B MONOLITHIC SERIAL INTERFACE COMBINED PCM CODEC AND FILTER

SCTS031D – MAY 1990 – REVISED JULY 1996

PRINCIPLES OF OPERATION

system reliability and design considerations

TP306xB, TP1306xB system reliability and design considerations are detailed in the following paragraphs.

latch-up

Latch-up is possible in all CMOS devices. It is caused by the firing of a parasitic SCR that is present due to the inherent nature of CMOS. When a latch-up occurs, the device draws excessive amounts of current and will continue to draw heavy current until power is removed. Latch-up can result in permanent damage to the device if supply current to the device is not limited.

Even though the TP306xB and TP1306xB devices are heavily protected against latch-up, it is still possible to cause latch-up under certain conditions in which excess current is forced into or out of one or more terminals. Latch-up can occur when the positive supply voltage drops momentarily below ground, when the negative supply voltage rises momentarily above ground, or possibly if a signal is applied to a terminal after power has been applied but before the ground is connected. This can happen if the device is hot-inserted into a card with the power applied, or if the device is mounted on a card with an edge connector, and the card is hot-inserted into a system with the power on.

To help ensure that latch-up does not occur, it is considered good design practice to connect a reversed biased Schottky diode (with a forward voltage drop of less than or equal to 0.4 V — 1N5711 or equivalent), between each power supply and GND (see Figure 3). If it is possible that a TP306xB- or TP1306xB-equipped card that has an edge connector could be hot-inserted into a powered-up system, it is also important to ensure that the ground edge connector traces are longer than the power and signal traces so that the card ground is always the first to make contact.

device power-up sequence

Latch-up can also occur if a signal source is connected without the device being properly grounded. A signal applied to one terminal could then find a ground through another signal terminal on the device. To ensure proper operation of the device and as a safeguard against this sort of latch-up, it is recommended the following power-up sequence always be used:

1. Ensure no signals are applied to the device before the power-up sequence is complete.
2. Connect GND.
3. Apply V_{BB} (most negative voltage).
4. Apply V_{CC} (most positive voltage).
5. Force a power down condition in the device.
6. Connect clocks.
7. Release power down condition.
8. Apply FSX and/or FXR synchronization pulses.
9. Apply signal inputs.

When powering down the device, this procedure should be followed in the reverse order.



POST OFFICE BOX 655303 • DALLAS, TEXAS 75265

PRINCIPALS OF OPERATION

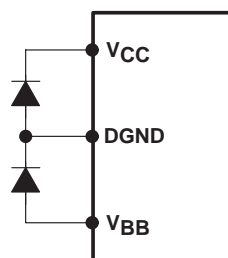

Figure 3. Diode Configuration for Latch-Up Protection Circuitry

internal sequencing

Power-on reset circuitry initializes the TP3064B, TP3067B, TP13064B, and TP13067B devices when power is first applied, placing it into the power-down mode. DX and VFRO outputs go into high-impedance states and all nonessential circuitry is disabled. A low level or clock applied to MCLKR/PDN powers up the device and activates all circuits. DX, a 3-state PCM data output, remains in the high-impedance state until the arrival of the second FSX pulse.

power supplies

All ground connections to each device should meet at a common point as close as possible to ANLG–GND. This minimizes the interaction of ground return currents flowing through a common bus impedance. V_{CC} and V_{BB} supplies should be decoupled by connecting 0.1- μ F decoupling capacitors between each power rail and this common point. These bypass capacitors must be connected as close as possible to V_{CC} and V_{BB} .

For best performance, the ground point of each codec/filter on a card should be connected to a common card ground in star formation rather than through a ground bus. This common ground point should be decoupled to V_{CC} and V_{BB} with 10- μ F capacitors.

synchronous operation

For synchronous operation, a clock is applied to MCLKX. MCLKR/PDN is used as a power-down control. A logic 0 applied to MCLKR powers-up the device and a high level powers it down. In either case, MCLKX is selected as the master clock for both receive and transmit direction. BCLKX must also have a bit clock applied to it. The selection of the proper internal divider for a master-clock frequency of 1.536 MHz, 1.544 MHz, or 2.048 MHz can be done using BCLKR/CLKSEL. The device automatically compensates for the 193rd clock pulse of each frame.

A fixed level on BCLKR/CLKSEL selects BCLKX as the bit clock for both the transmit and receive directions. Table 1 indicates the frequencies of operation that can be selected depending on the state of BCLKR/CLKSEL. In the synchronous mode, BCLKX may be in the range from 64 kHz to 2.048 MHz but must be synchronous with MCLKX.

The encoding cycle begins with each FSX pulse, and the PCM data from the previous cycle is shifted out of the enabled DX output on the rising edge of BCLKX. After eight-bit clock periods, the 3-state DX output is returned to the high-impedance state. With an FSR pulse, PCM data is latched via DR on the falling edge of BCLKX (or BCLKR, if running). FSX and FSR must be synchronous with MCLKX and MCLKR.

TP3064B, TP3067B, TP13064B, TP13067B
MONOLITHIC SERIAL INTERFACE
COMBINED PCM CODEC AND FILTER

SCTS031D – MAY 1990 –REVISED JULY 1996

PRINCIPALS OF OPERATION

asynchronous operation

For asynchronous operation, separate transmit and receive clocks can be applied. MCLKX and MCLKR must be 2.048 MHz for the TP3064B and TP13064B, 1.536 MHz or 1.544 MHz for the TP3067B and TP13067B and need not be synchronous. However, for best performance, MCLKR should be synchronous with MCLKX. This is easily achieved by applying only static logic levels to MCLKR/PDN. This connects MCLKX to all internal MCLKR functions. For 1.544-MHz operation, the device compensates for the 193rd clock pulse of each frame. Each encoding cycle is started with FSX, and FSX must be synchronous with MCLKX and BCLKX. Each decoding cycle is started with FSR, and FSR must be synchronous with BCLKR. The logic levels shown in Table 1 are not valid in the asynchronous mode. BCLKX and BCLKR can operate from 64 kHz to 2.048 MHz.

short-frame sync operation

The device can operate with either a short- or a long-frame sync pulse. On power up, the device automatically goes into the short-frame mode where both FSX and FSR must be one bit-clock period long, with timing relationships specified in Figure 1. With FSX high during a falling edge of BCKLX, the next rising edge of BCLKX enables the 3-state output buffer, DX, which outputs the sign bit. The remaining seven bits are clocked out on the following seven rising edges, and the next falling edge disables DX. With FSR high during a falling edge of BCLKR (BCLKX in synchronous mode), the next falling edge of BCLKR latches in the sign bit. The following seven falling edges latch in the seven remaining bits. The short-frame sync pulse may be utilized in either the synchronous or asynchronous mode.

Table 1. Selection of Master-Clock Frequencies

BCLKR/CLKSEL	MASTER-CLOCK FREQUENCY SELECTED	
	TP3064B, TP13064B	TP3067B, TP13067B
Clock Input	1.536 MHz or 1.544 MHz	2.048 MHz
Logic Input L (sync mode only)	2.048 MHz	1.536 MHz or 1.544 MHz
Logic Input H (open) (sync mode only)	1.536 MHz or 1.544 MHz	2.048 MHz

long-frame sync operation

Both FSX and FSR must be three or more bit-clock periods long to use the long-frame sync mode with timing relationships as shown in Figure 2. Using the transmit frame sync (FSX), the device detects whether a short- or long-frame sync pulse is being used. For 64-kHz operation, the frame-sync pulse must be kept low for a minimum of 160 ns. The rising edge of FSX or BCLKX, whichever occurs later, enables the DX 3-state output buffer. The first bit clocked out is the sign bit. The next seven rising edges of BCLKX edges clock out the remaining seven bits. The falling edge of BCLKX following the eighth rising edge or FSX going low, whichever occurs later, disables DX. A rising edge on FSR, the receive frame sync pulse, causes the PCM data at DR to be latched in on the next eight falling edges of BCLKR (BCLKX in synchronous mode). The long-frame sync pulse can be used in either the synchronous or asynchronous mode.



PRINCIPALS OF OPERATION

transmit section

The transmit section input is an operational amplifier with provision for gain adjustment using two external resistors. Gains in excess of 20 dB across the audio pass band are possible via low noise and wide bandwidth. The operational amplifier drives a unity-gain filter consisting of an RC active prefilter followed by an eight-order switched-capacitor band-pass filter clocked at 256 kHz. The output of this filter directly drives the encoder sample-and-hold circuit. As per μ -law (TP3064B and TP13064B) or A-law (TP3067B and TP13067B) coding conventions, the ADC is a companding type. A precision voltage reference provides a input overload of nominally 2.5-V peak. The sampling of the filter output is controlled by the FSX frame-sync pulse. Then the successive-approximation encoding cycle begins. The 8-bit code is loaded into a buffer and shifted out through DX at the next FSX pulse. The total encoding delay is approximately 290 μ s. Any offset voltage due to the filters or comparator is cancelled by sign bit integration (see Table 2).

Table 2. Encoding Format at DX Output

	TP3064B, TP13064B μ -LAW	TP3067B, TP13067B A-LAW (INCLUDES EVEN-BIT INVERSION)
$V_I = +$ Full scale	1 0 0 0 0 0 0 0	1 0 1 0 1 0 1 0
$V_I = 0$	1 1 1 1 1 1 1 1 0 1 1 1 1 1 1 1	1 1 0 1 0 1 0 1 0 1 0 1 0 1 0 1
$V_I = -$ Full scale	0 0 0 0 0 0 0 0	0 0 1 0 1 0 1 0

receive section

The receive section consists of an expanding DAC that drives a fifth-order low-pass filter clocked at 256 kHz. The decoder is μ -law (TP3064B and TP13064B) or A-law (TP3067B and TP13067B) and the fifth-order low-pass filter corrects for the $(\sin x)/x$ attenuation caused by the 8-kHz sample/hold. The filter is followed by a second-order RC active post-filter with its output at VFRO. The receive section is unity-gain but gain can be added by using the power amplifiers. At FSR, the data at DR is clocked in on the falling edge of the next eight BCLKR (BCLKX) periods. At the end of the decoder time slot, the decoding cycle begins and 10 μ s later the decoder DAC output is updated. The decoder delay is about 10 μ s (decoder update) plus 110 μ s (filter delay) plus 62.5 μ s (1/2 frame), or a total of approximately 180 μ s.

receive power amplifiers

Two inverting-mode power amplifiers are provided for directly driving a match-line interface transformer. The gain of the first power amplifier can be adjusted to boost the ± 2.5 -V peak output signal from the receive filter up to the ± 3.3 -V peak into an unbalanced 300- Ω load, or ± 4 V into an unbalanced 15-k Ω load. The second power amplifier is internally connected in unity-gain inverting mode to give 6-dB signal gain for balanced loads.

Maximum power transfer to a 600- Ω subscriber line termination is obtained by differentially driving a balanced transformer with $\sqrt{2}:1$ turns ratio, as shown in Figure 3. A total peak power of 15.6 dBm can be delivered to the load plus termination.

TP3064B, TP3067B, TP13064B, TP13067B
MONOLITHIC SERIAL INTERFACE
COMBINED PCM CODEC AND FILTER

SCTS031D – MAY 1990 –REVISED JULY 1996

APPLICATION INFORMATION

power supplies

While the pins of the TP1306xB and TP306xB families are well protected against electrical misuse, it is recommended that the standard CMOS practice be followed ensuring that ground is connected to the device before any other connections are made. In applications where the printed-circuit board can be plugged into a hot socket with power and clocks already present, an extra long ground pin in the connector should be used.

All ground connections to each device should meet at a common point as close as possible to ANLG GND. This minimizes the interaction of ground return currents flowing through a common bus impedance. V_{CC} and V_{BB} supplies should be decoupled by connecting 0.1- μ F decoupling capacitors to this common point. These bypass capacitors must be connected as close as possible to V_{CC} and V_{BB} .

For best performance, the ground point of each codec/filter on a card should be connected to a common card ground in star formation rather than via a ground bus. This common ground point should be decoupled to V_{CC} and V_{BB} with 10- μ F capacitors.



POST OFFICE BOX 655303 • DALLAS, TEXAS 75265

APPLICATION INFORMATION

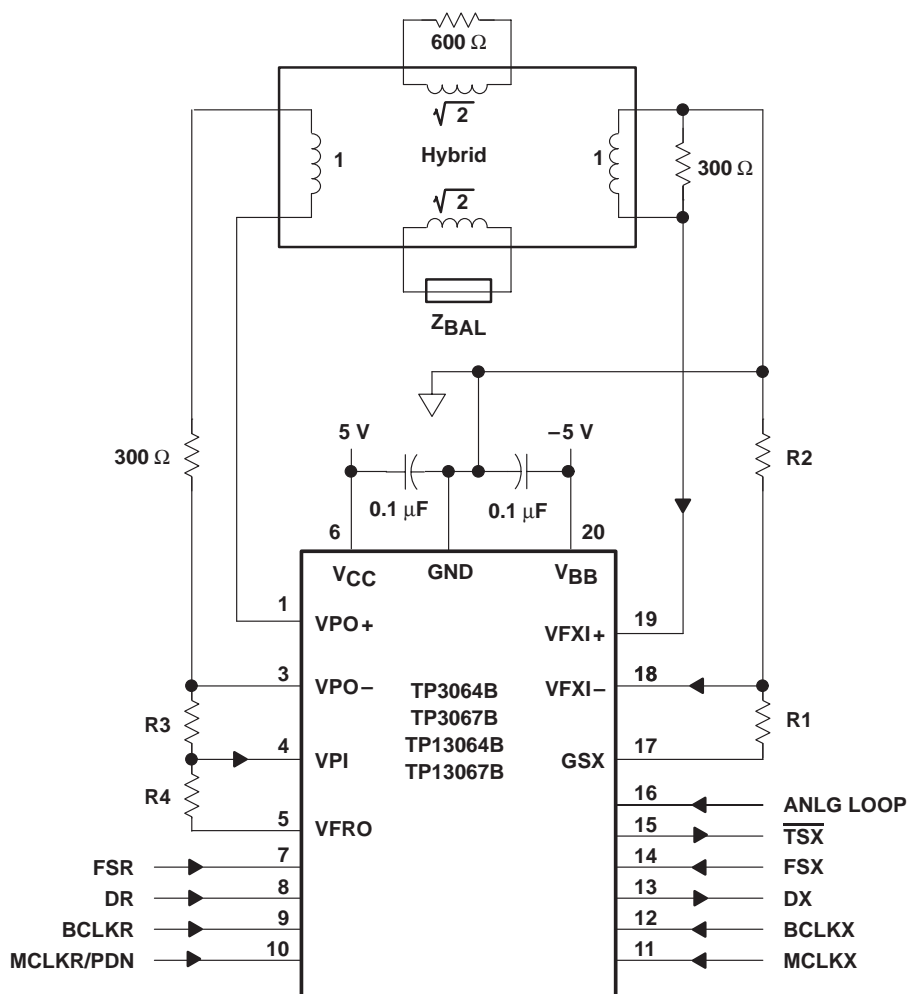

NOTES: A. Transmit gain = $20 \log \left(\frac{R1 + R2}{R2} \right)$, $(R1 + R2) \geq 10 \text{ k}\Omega$

B. Receive gain = $20 \log \left(\frac{2 \times R3}{R4} \right)$, $R4 \geq 10 \text{ k}\Omega$

Figure 4. Typical Synchronous Application

TP3064B, TP3067B, TP13064B, TP13067B
MONOLITHIC SERIAL INTERFACE
COMBINED PCM CODEC AND FILTER

SCTS031D – MAY 1990 –REVISED JULY 1996

APPLICATION INFORMATION

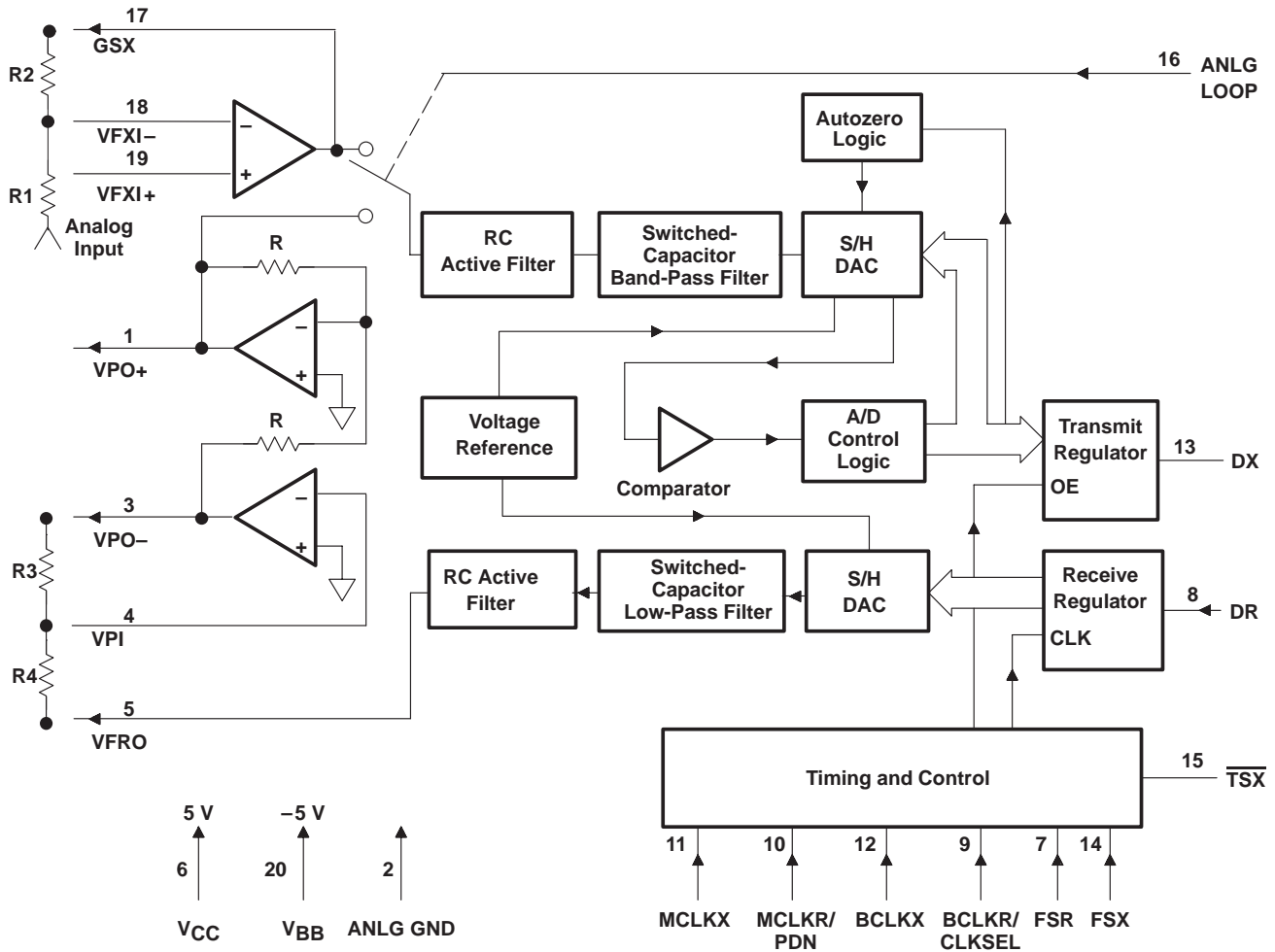

IMPORTANT NOTICE

Texas Instruments and its subsidiaries (TI) reserve the right to make changes to their products or to discontinue any product or service without notice, and advise customers to obtain the latest version of relevant information to verify, before placing orders, that information being relied on is current and complete. All products are sold subject to the terms and conditions of sale supplied at the time of order acknowledgement, including those pertaining to warranty, patent infringement, and limitation of liability.

TI warrants performance of its semiconductor products to the specifications applicable at the time of sale in accordance with TI's standard warranty. Testing and other quality control techniques are utilized to the extent TI deems necessary to support this warranty. Specific testing of all parameters of each device is not necessarily performed, except those mandated by government requirements.

CERTAIN APPLICATIONS USING SEMICONDUCTOR PRODUCTS MAY INVOLVE POTENTIAL RISKS OF DEATH, PERSONAL INJURY, OR SEVERE PROPERTY OR ENVIRONMENTAL DAMAGE ("CRITICAL APPLICATIONS"). TI SEMICONDUCTOR PRODUCTS ARE NOT DESIGNED, AUTHORIZED, OR WARRANTED TO BE SUITABLE FOR USE IN LIFE-SUPPORT DEVICES OR SYSTEMS OR OTHER CRITICAL APPLICATIONS. INCLUSION OF TI PRODUCTS IN SUCH APPLICATIONS IS UNDERSTOOD TO BE FULLY AT THE CUSTOMER'S RISK.

In order to minimize risks associated with the customer's applications, adequate design and operating safeguards must be provided by the customer to minimize inherent or procedural hazards.

TI assumes no liability for applications assistance or customer product design. TI does not warrant or represent that any license, either express or implied, is granted under any patent right, copyright, mask work right, or other intellectual property right of TI covering or relating to any combination, machine, or process in which such semiconductor products or services might be or are used. TI's publication of information regarding any third party's products or services does not constitute TI's approval, warranty or endorsement thereof.