

SN75LVDS32, SN75LVDS9637 HIGH-SPEED DIFFERENTIAL LINE RECEIVERS

SLLS360A – JUNE 1999 – REVISED MARCH 2000

- Meets or Exceeds the Requirements of ANSI TIA/EIA-644 Standard
- Operates With a Single 3.3-V Supply
- Designed for Signaling Rate of Up To 155 Mbps
- Differential Input Thresholds ± 100 mV Max
- Low-Voltage TTL (LVTTTL) Logic Output Levels
- Open-Circuit Fail Safe
- Characterized For Operation From 0°C to 70°C

description

The SN75LVDS32 and SN75LVDS9637 are differential line receivers that implement the electrical characteristics of low-voltage differential signaling (LVDS). This signaling technique lowers the output voltage levels of 5-V differential standard levels (such as EIA/TIA-422B) to reduce the power, increase the switching speeds, and allow operation with a 3.3-V supply rail. Any of the four differential receivers provides a valid logical output state with a ± 100 mV allow operation with a differential input voltage within the input common-mode voltage range. The input common-mode voltage range allows 1 V of ground potential difference between two LVDS nodes.

The intended application of these devices and signaling technique is both point-to-point and multidrop (one driver and multiple receivers) data transmission over controlled impedance media of approximately 100 Ω . The transmission media may be printed-circuit board traces, backplanes, or cables. The ultimate rate and distance of data transfer is dependent upon the attenuation characteristics of the media and the noise coupling to the environment.

The SN75LVDS32 and SN75LVDS9637 are characterized for operation from 0°C to 70°C.

SN75LVDS32D (Marked as 75LVDS32)
(TOP VIEW)

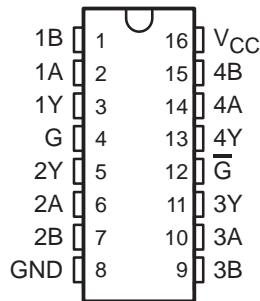

SN75LVDS9637D (Marked as DF637 or 7L9637)
(TOP VIEW)

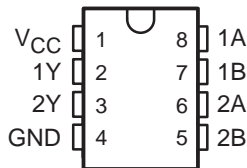

Please be aware that an important notice concerning availability, standard warranty, and use in critical applications of Texas Instruments semiconductor products and disclaimers thereto appears at the end of this data sheet.

PRODUCTION DATA information is current as of publication date. Products conform to specifications per the terms of Texas Instruments standard warranty. Production processing does not necessarily include testing of all parameters.

 **TEXAS
INSTRUMENTS**

POST OFFICE BOX 655303 • DALLAS, TEXAS 75265

Copyright © 1999, Texas Instruments Incorporated

SN75LVDS32, SN75LVDS9637 HIGH-SPEED DIFFERENTIAL LINE RECEIVERS

SLLS360A – JUNE 1999 – REVISED MARCH 2000

logic diagram

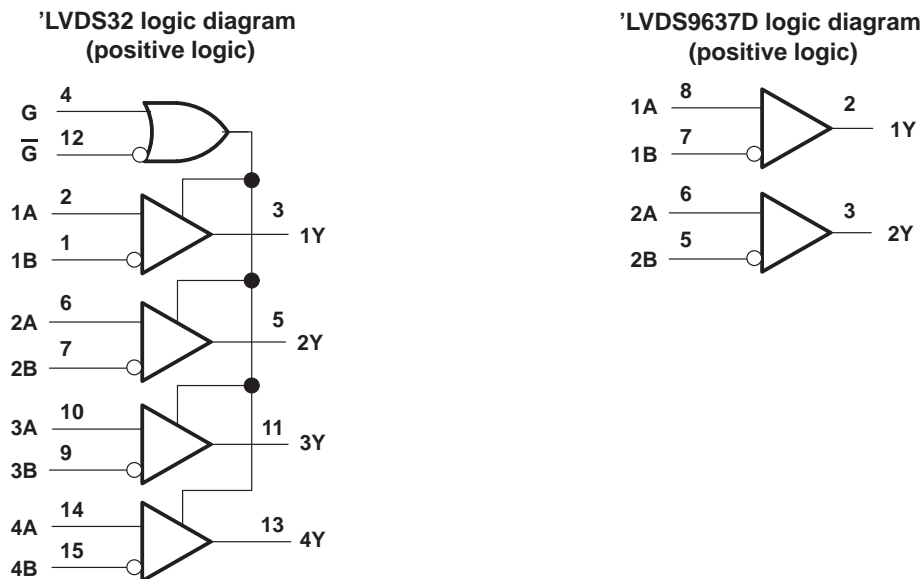

Function Tables

SN75LVDS32			
DIFFERENTIAL INPUT	ENABLES		OUTPUT
A, B	G	\bar{G}	Y
$V_{ID} \geq 100 \text{ mV}$	H	X	H
	X	L	H
$-100 \text{ mV} < V_{ID} < 100 \text{ mV}$	H	X	?
	X	L	?
$V_{ID} \leq -100 \text{ mV}$	H	X	L
	X	L	L
X	L	H	Z
Open	H	X	H
	X	L	H

H = high level, L = low level, X = irrelevant,
Z = high impedance (off), ? = indeterminate

SN75LVDS32, SN75LVDS9637 HIGH-SPEED DIFFERENTIAL LINE RECEIVERS

SLLS360A – JUNE 1999 – REVISED MARCH 2000

logic symbol†

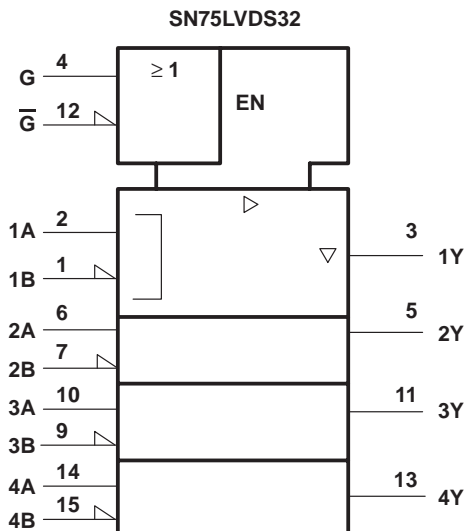

† This symbol is in accordance with ANSI/IEEE Std 91-1984 and IEC Publication 617-12.

Function Table

SN75LVDS9637

DIFFERENTIAL INPUT	OUTPUT
A, B	Y
$V_{ID} \geq 100 \text{ mV}$	H
$-100 \text{ mV} < V_{ID} < 100 \text{ mV}$?
$V_{ID} \leq -100 \text{ mV}$	L
Open	H

H = high level, L = low level, ? = indeterminate

logic symbol†

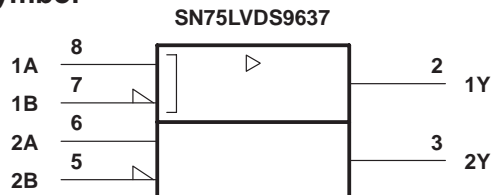

† This symbol is in accordance with ANSI/IEEE Std 91-1984 and IEC Publication 617-12.

SN75LVDS32, SN75LVDS9637 HIGH-SPEED DIFFERENTIAL LINE RECEIVERS

SLLS360A – JUNE 1999 – REVISED MARCH 2000

equivalent input and output schematic diagrams

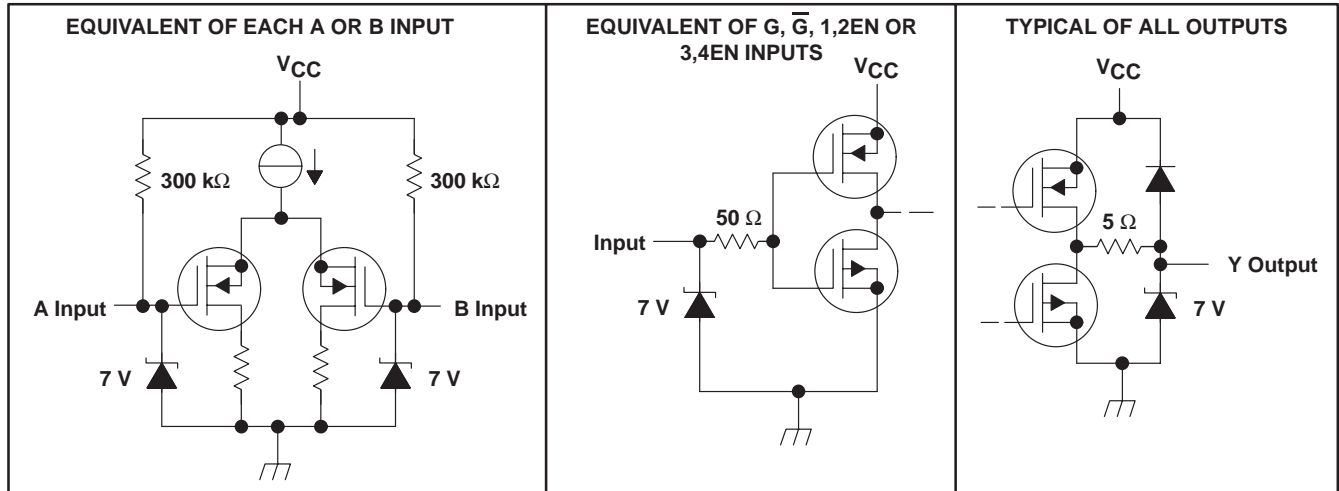

absolute maximum ratings over operating free-air temperature range (unless otherwise noted)†

Supply voltage range, V_{CC} (see Note 1)	-0.5 V to 4 V
Input voltage range, V_I	-0.5 V to $V_{CC} + 0.5$ V
Input voltage range, V_I (A or B)	-0.5 V to 4 V
Continuous total power dissipation	See Dissipation Rating Table
Storage temperature range, T_{stg}	-65°C to 150°C
Lead temperature 1,6 mm (1/16 inch) from case for 10 seconds	260°C

† Stresses beyond those listed under “absolute maximum ratings” may cause permanent damage to the device. These are stress ratings only, and functional operation of the device at these or any other conditions beyond those indicated under “recommended operating conditions” is not implied. Exposure to absolute-maximum-rated conditions for extended periods may affect device reliability.

NOTE 1: All voltages, except differential I/O bus voltages, are with respect to the network ground terminal.

DISSIPATION RATING TABLE

PACKAGE	$T_A \leq 25^\circ\text{C}$ POWER RATING	DERATING FACTOR‡ ABOVE $T_A = 25^\circ\text{C}$	$T_A = 70^\circ\text{C}$ POWER RATING
D (8)	725 mW	5.8 mW/°C	464 mW
D (16)	950 mW	7.6 mW/°C	608 mW

‡ This is the inverse of the junction-to-ambient thermal resistance when board mounted and with no air flow.

recommended operating conditions

		MIN	NOM	MAX	UNIT
Supply voltage, V_{CC}		3	3.3	3.6	V
High-level input voltage, V_{IH}	G, \overline{G}	2			V
Low-level input voltage, V_{IL}	G, \overline{G}			0.8	V
Magnitude of differential input voltage, $ V_{ID} $		0.1		0.6	V
Common-mode input voltage, V_{IC} (see Figure 1)		$\frac{ V_{ID} }{2}$	$2.4 - \frac{ V_{ID} }{2}$		V
			$V_{CC} - 0.8$		V
Operating free-air temperature, T_A		0		70	°C

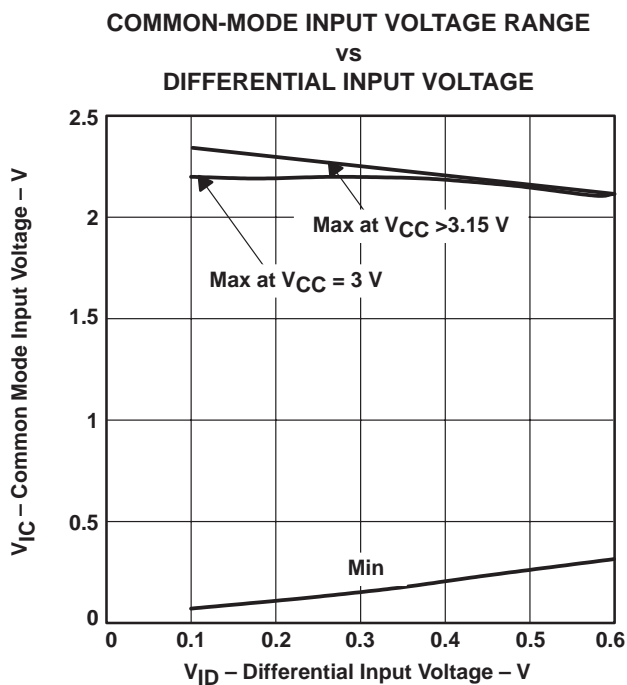

SN75LVDS32, SN75LVDS9637 HIGH-SPEED DIFFERENTIAL LINE RECEIVERS

SLLS360A – JUNE 1999 – REVISED MARCH 2000

SN75LVDSxxxx electrical characteristics over recommended operating conditions (unless otherwise noted)

PARAMETER		TEST CONDITIONS	SN75LVDS32, SN75LVDS9637			UNIT
			MIN	TYP†	MAX	
V _I TH+	Positive-going differential input voltage threshold	See Figure 2 and Table 1	100			mV
V _I TH-	Negative-going differential input voltage threshold‡		-100			mV
V _{OH}	High-level output voltage	I _{OH} = -8 mA	2.4			V
V _{OL}	Low-level output voltage	I _{OL} = 8 mA	0.4			V
I _{CC}	Supply current	SN75LVDS32	10 18			mA
		SN75LVDS9637	0.25 0.5			
I _I	Input current (A or B inputs)	Enabled, No load	5.5 10			µA
		Disabled	-2 -10 -20			
I _{I(OFF)}	Power-off input current (A or B inputs)	V _I = 0	-1.2 -3			µA
I _{IH}	High-level input current (G, or \overline{G} inputs)	V _{CC} = 0, V _I = 3.6 V	6 20			µA
I _{IL}	Low-level input current (G, or \overline{G} inputs)	V _{IH} = 2 V	10			µA
I _{IL}	Low-level input current (G, or \overline{G} inputs)	V _{IL} = 0.8 V	10			µA
I _{OZ}	High-impedance output current	V _O = 0 or V _{CC}	±10			µA

† All typical values are at T_A = 25°C and with V_{CC} = 3.3 V.

‡ The algebraic convention, in which the less positive (more negative) limit is designated minimum, is used in this data sheet for the negative-going differential input voltage threshold only.

SN75LVDSxxxx switching characteristics over recommended operating conditions (unless otherwise noted)

PARAMETER		TEST CONDITIONS	SN75LVDS32, SN75LVDS9637			UNIT
			MIN	TYP†	MAX	
t _{pLH}	Propagation delay time, low-to-high-level output	C _L = 100 pF, See Figure 3	2.1 6			ns
t _{pHL}	Propagation delay time, high-to-low-level output		2.1 6			ns
t _{sk(p)}	Pulse skew ((t _{pHL} - t _{pLH}))		0.6 1.5			ns
t _{sk(o)}	Channel-to-channel output skew†		0.7 1.5			ns
t _{sk(pp)}	Part-to-part skew‡		0.6			ns
t _r	Output signal rise time, 20% to 80%		0.6			ns
t _f	Output signal fall time, 80% to 20%		1			ns
t _{pHZ}	Propagation delay time, high-level-to-high-impedance output	See Figure 4	25			ns
t _{pLZ}	Propagation delay time, low-level-to-high-impedance output		25			ns
t _{pZH}	Propagation delay time, high-impedance-to-high-level output		25			ns
t _{pZL}	Propagation delay time, high-impedance-to-low-level output		25			ns

† All typical values are at 25°C and with a 3.3-V supply.

‡ t_{sk(p)} is the magnitude of the time difference between the high-to-low and low-to-high propagation delay times at an output

§ t_{sk(o)} is the magnitude of the time difference between the outputs of a single device with all of their inputs connected together.

¶ t_{sk(pp)} is the magnitude of the difference in propagation delay times between any specified terminals of two devices when both devices operate with the same supply voltages, same temperature, and have identical packages and test circuits.



PARAMETER MEASUREMENT INFORMATION

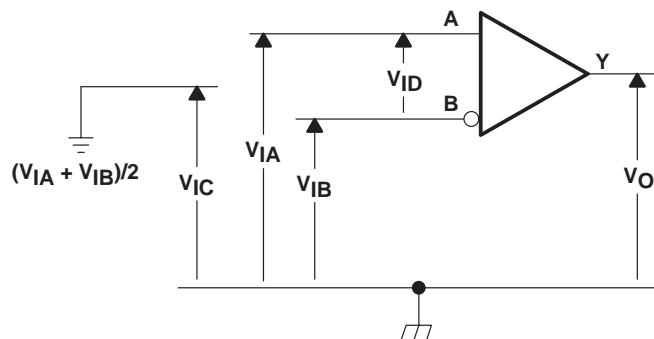

Figure 2. Voltage Definitions

Table 1. Receiver Minimum and Maximum Input Threshold Test Voltages

APPLIED VOLTAGES		RESULTING DIFFERENTIAL INPUT VOLTAGE	RESULTING COMMON-MODE INPUT VOLTAGE
V_{IA}	V_{IB}	V_{ID}	V_{IC}
1.25 V	1.15 V	100 mV	1.2 V
1.15 V	1.25 V	-100 mV	1.2 V
2.4 V	2.3 V	100 mV	2.35 V
2.3 V	2.4 V	-100 mV	2.35 V
0.1 V	0 V	100 mV	0.05 V
0 V	0.1 V	-100 mV	0.05 V
1.5 V	0.9 V	600 mV	1.2 V
0.9 V	1.5 V	-600 mV	1.2 V
2.4 V	1.8 V	600 mV	2.1 V
1.8 V	2.4 V	-600 mV	2.1 V
0.6 V	0 V	600 mV	0.3 V
0 V	0.6 V	-600 mV	0.3 V

SN75LVDS32, SN75LVDS9637 HIGH-SPEED DIFFERENTIAL LINE RECEIVERS

SLLS360A – JUNE 1999 – REVISED MARCH 2000

PARAMETER MEASUREMENT INFORMATION

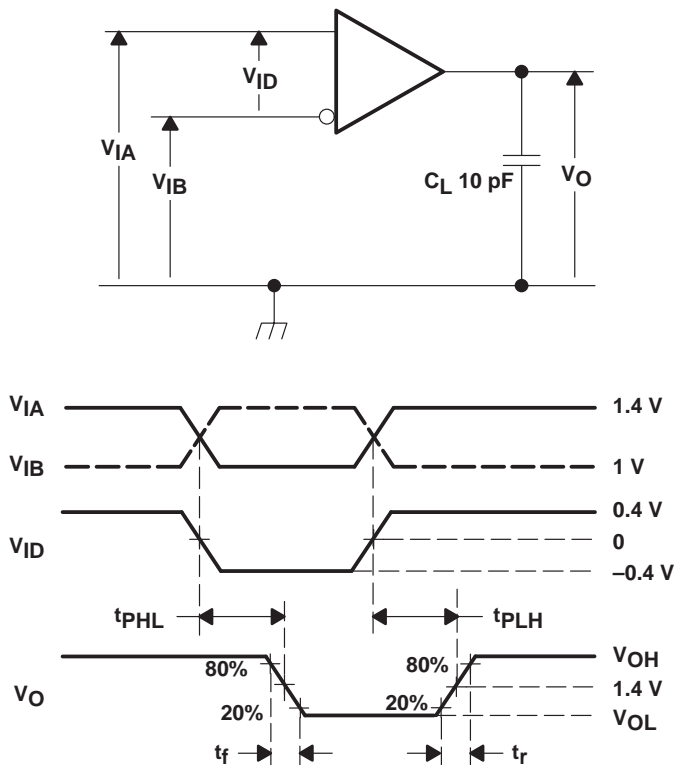

- NOTES: A. All input pulses are supplied by a generator having the following characteristics: t_r or $t_f \leq 1 \text{ ns}$, pulse repetition rate (PRR) = 50 Mpps, pulse width = $10 \pm 0.2 \text{ ns}$.
B. C_L includes instrumentation and fixture capacitance within 6 mm of the D.U.T.

Figure 3. Timing Test Circuit and Wave Forms

PARAMETER MEASUREMENT INFORMATION

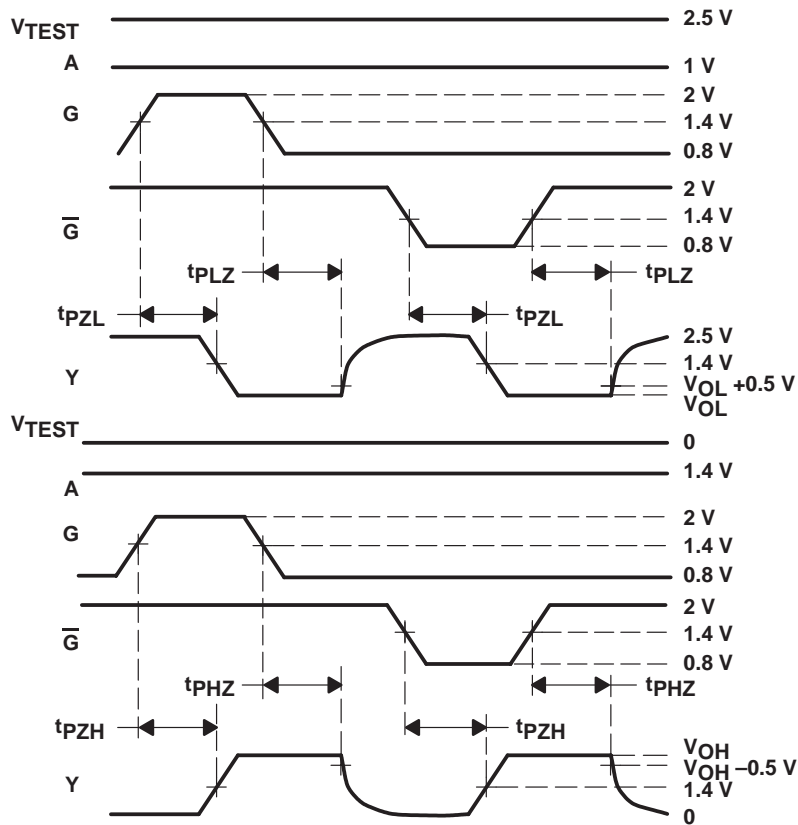
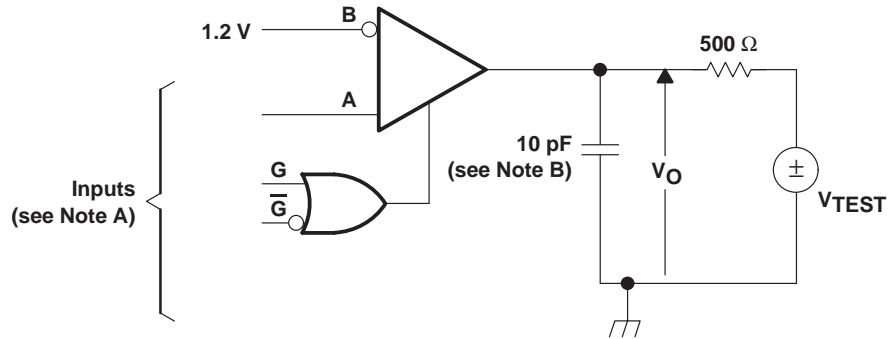

- NOTES: A. All input pulses are supplied by a generator having the following characteristics: t_r or $t_f \leq 1$ ns, pulse repetition rate (PRR) = 0.5 Mpps, pulse width = 500 ± 10 ns.
B. C_L includes instrumentation and fixture capacitance within 6 mm of the D.U.T.

Figure 4. Enable/Disable Time Test Circuit and Wave Forms

SN75LVDS32, SN75LVDS9637 HIGH-SPEED DIFFERENTIAL LINE RECEIVERS

SLLS360A – JUNE 1999 – REVISED MARCH 2000

APPLICATION INFORMATION

using an LVDS receiver with RS-422 data

Receipt of data from a TIA/EIA-422 line driver may be accomplished using a TIA/EIA-644 line receiver with the addition of an attenuator circuit. This technique gives the user a very high-speed and low-power 422 receiver.

If the ground noise between the transmitter and receiver is not a concern (less than ± 1 V), the answer can be as simple as shown below in Figure 5. The use of a resistor divider circuit in front of the LVDS receiver attenuates the 422 differential signal to LVDS levels.

The resistors present a total differential load of $100\ \Omega$ to match the characteristic impedance of the transmission line and to reduce the signal 10:1. The maximum 422 differential output signal or 6 V is reduced to 600 mV. The high input impedance of the LVDS receiver prevents input bias offsets and maintains a better than 200-mV differential input voltage threshold at the inputs to the divider. This circuit is used in front of each LVDS channel that also receives 422 signals.

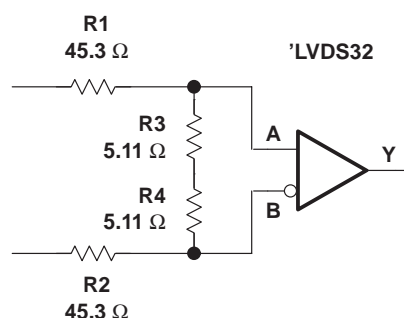

NOTE A: The components used were standard values.

R1, R2 = NRC12F45R3TR, NIC Components, 45.3 Ohm, 1/8W, 1%, 1206 Package

R3, R4 = NRC12F5R11TR, NIC Components, 5.11 Ohm, 1/8W, 1%, 1206 Package

The resistor values do not need to be 1% tolerance. However, it can be difficult locating a supplier of resistors having values less than $100\ \Omega$ in stock and readily available. The user may find other suppliers with comparable parts having tolerances of 5% or even 10%. These parts are adequate for use in this circuit.

Figure 5. RS-422 Data Input to an LVDS Receiver Under Low Ground Noise Conditions

If ground noise between the RS-422 driver and LVDS receiver is a concern, then the common-mode voltage must be attenuated. The circuit must then be modified to connect the node between R3 and R4 to the LVDS receiver ground. This modification to the circuit increases the common-mode voltage from ± 1 V to greater than ± 4.5 V.

APPLICATIONS INFORMATION

The devices are generally used as building blocks for high-speed point-to-point data transmission where ground differences are less than 1 V. Devices can interoperate with RS-422, PECL, and IEEE-P1596. Drivers/receivers approach ECL speeds without the power and dual supply requirements.

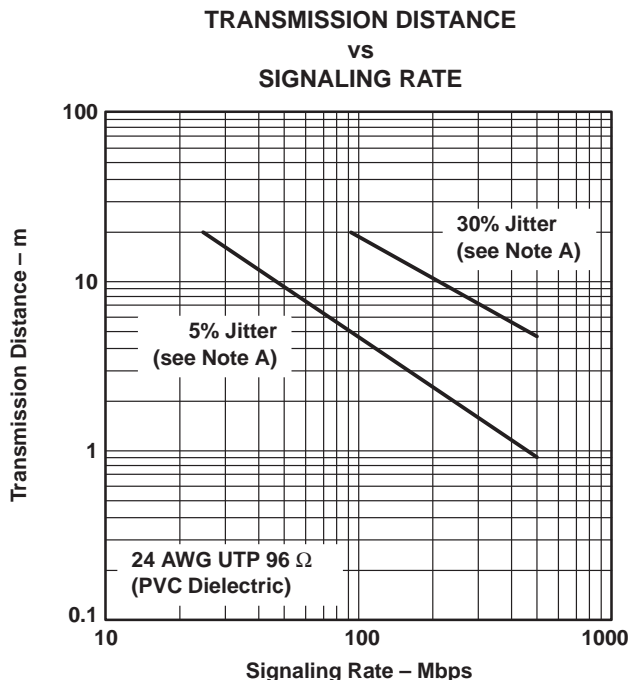

NOTE A: This parameter is the percentage of distortion of the unit interval (UI) with a pseudo-random data pattern.

Figure 6. Typical Transmission Distance Versus Signaling Rate

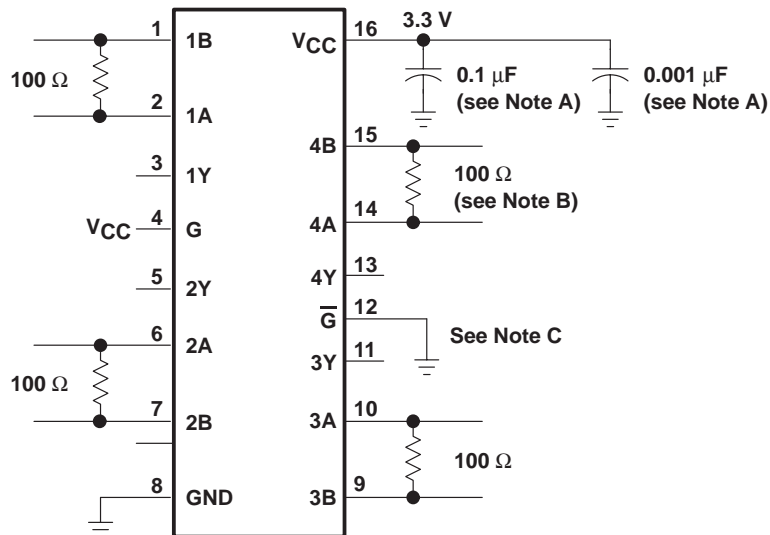

- NOTES: A. Place a 0.1 μ F and a 0.001 μ F Z5U ceramic, mica or polystyrene dielectric, 0805 size, chip capacitor between V_{CC} and the ground plane. The capacitors should be located as close as possible to the device terminals.
B. The termination resistance value should match the nominal characteristic impedance of the transmission media with $\pm 10\%$.
C. Unused enable inputs should be tied to V_{CC} or GND as appropriate.

Figure 7. Typical Application Circuit Schematic

SN75LVDS32, SN75LVDS9637 HIGH-SPEED DIFFERENTIAL LINE RECEIVERS

SLLS360A – JUNE 1999 – REVISED MARCH 2000

APPLICATION INFORMATION

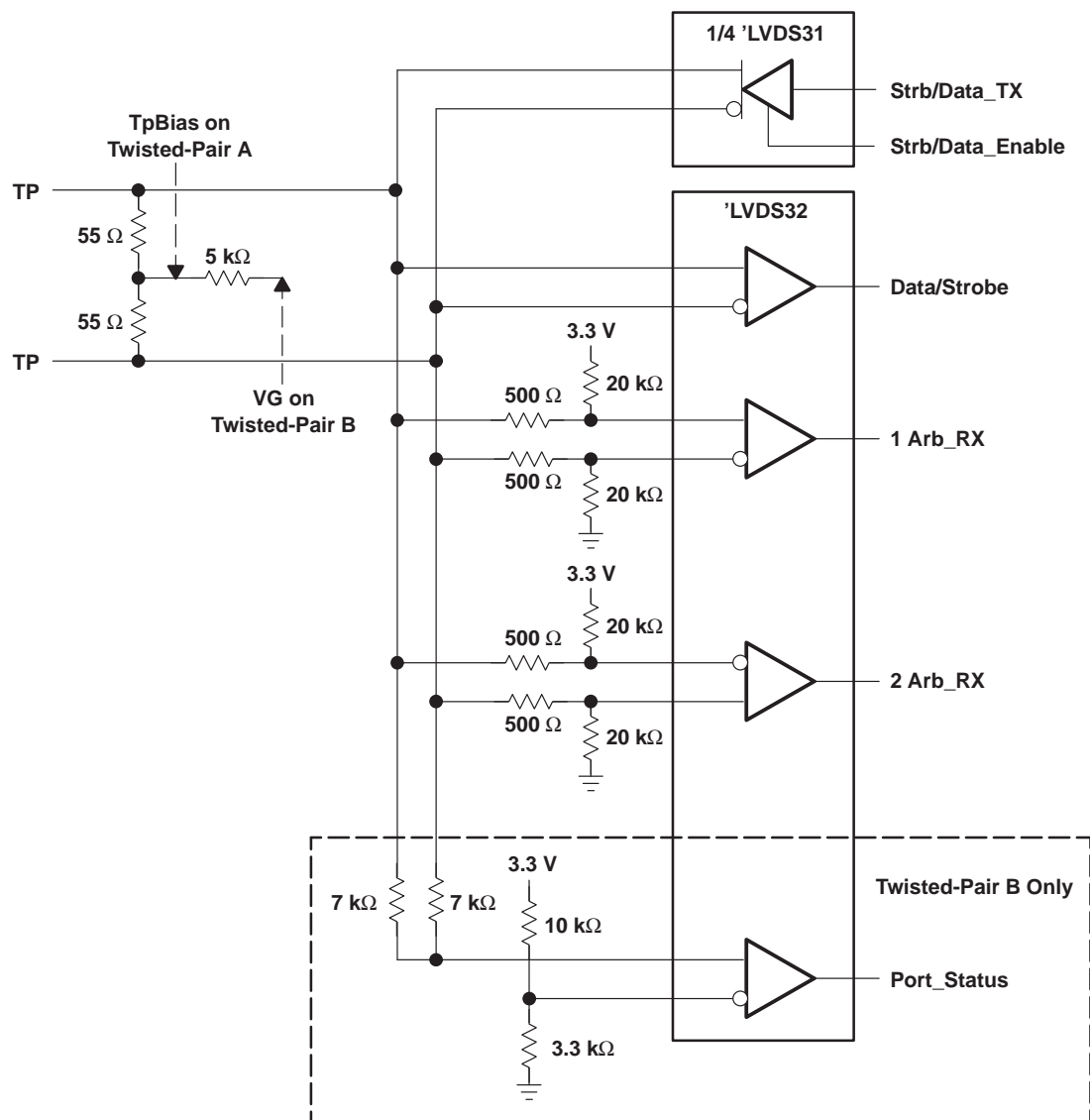

- NOTES: A. Resistors are leadless thick-film (0603) 5% tolerance.
 B. Decoupling capacitance is not shown but recommended.
 C. V_{CC} is 3 V to 3.6 V.
 D. The differential output voltage of the 'LVDS31 can exceed that allowed by IEEE1394.

Figure 8. 100-Mbps IEEE 1394 Transceiver

APPLICATION INFORMATION

fail safe

One of the most common problems with differential signaling applications is how the system responds when no differential voltage is present on the signal pair. The LVDS receiver is like most differential line receivers, in that its output logic state can be indeterminate when the differential input voltage is between -100 mV and 100 mV if it is within its recommended input common-mode voltage range. TI's LVDS receiver is different in how it handles the open-input circuit situation, however.

Open-circuit means that there is little or no input current to the receiver from the data line itself. This could be when the driver is in a high-impedance state or the cable is disconnected. When this occurs, the LVDS receiver will pull each line of the signal pair to near V_{CC} through 300 -k Ω resistors as shown in Figure 9. The fail-safe feature uses an AND gate with input voltage thresholds at about 2.3 V to detect this condition and force the output to a high level, regardless of the differential input voltage.

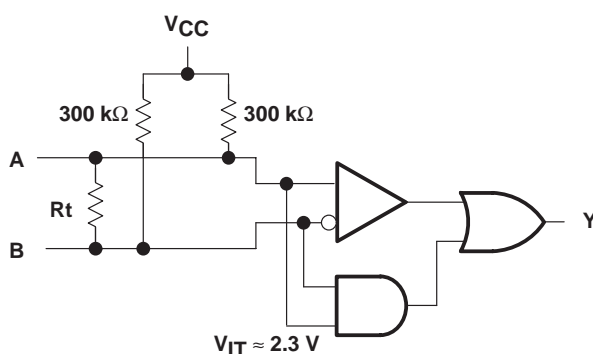

Figure 9. Open-Circuit Fail Safe of the LVDS Receiver

It is only under these conditions that the output of the receiver will be valid with less than a 100 -mV differential input voltage magnitude. The presence of the termination resistor, R_t , does not affect the fail-safe function as long as it is connected as shown in the figure. Other termination circuits may allow a dc current to ground that could defeat the pullup currents from the receiver and the fail-safe feature.

SN75LVDS32, SN75LVDS9637 HIGH-SPEED DIFFERENTIAL LINE RECEIVERS

SLLS360A – JUNE 1999 – REVISED MARCH 2000

APPLICATION INFORMATION

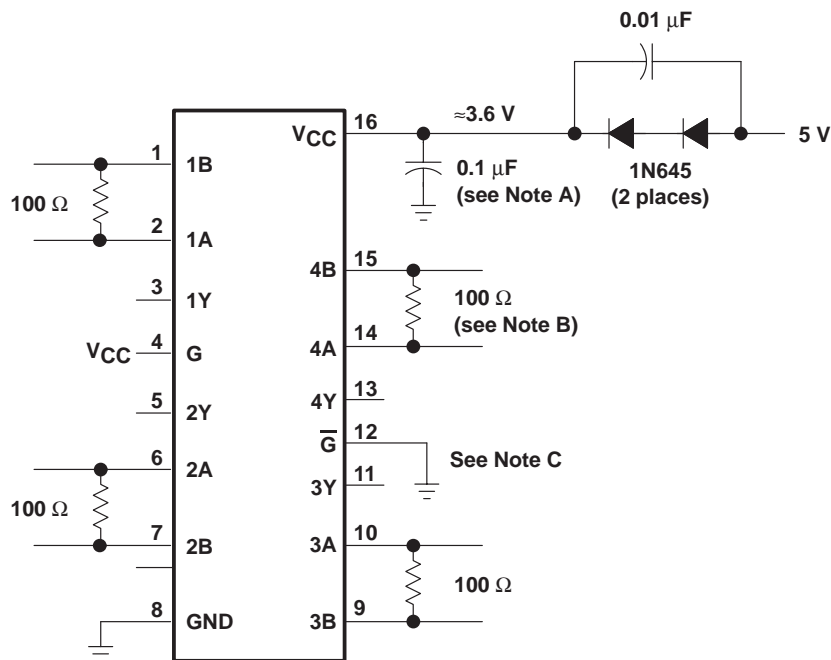

- NOTES: A. Place a 0.1 μF Z5U ceramic, mica or polystyrene dielectric, 0805 size, chip capacitor between V_{CC} and the ground plane. The capacitor should be located as close as possible to the device terminals.
- B. The termination resistance value should match the nominal characteristic impedance of the transmission media with ±10%.
- C. Unused enable inputs should be tied to V_{CC} or GND as appropriate.

Figure 10. Operation with 5-V Supply

related information

IBIS modeling is available for this device. Please contact the local TI sales office or the TI Web site at www.ti.com for more information.

For more application guidelines, please see the following documents:

- *Low-Voltage Differential Signalling Design Notes* (SLLA014)
- *Interface Circuits for TIA/EIA-644 (LVDS)* (SLLA038)
- *Reducing EMI with LVDS* (SLLA030)
- *Slew Rate Control of LVDS Circuits* (SLLA034)
- *Using an LVDS Receiver with RS-422 Data* (SLLA031)
- *Evaluating the LVDS EVM* (SLLA033)

SN75LVDS32, SN75LVDS9637 HIGH-SPEED DIFFERENTIAL LINE RECEIVERS

SLLS360A – JUNE 1999 – REVISED MARCH 2000

MECHANICAL INFORMATION

D (R-PDSO-G**)

PLASTIC SMALL-OUTLINE PACKAGE

14 PIN SHOWN

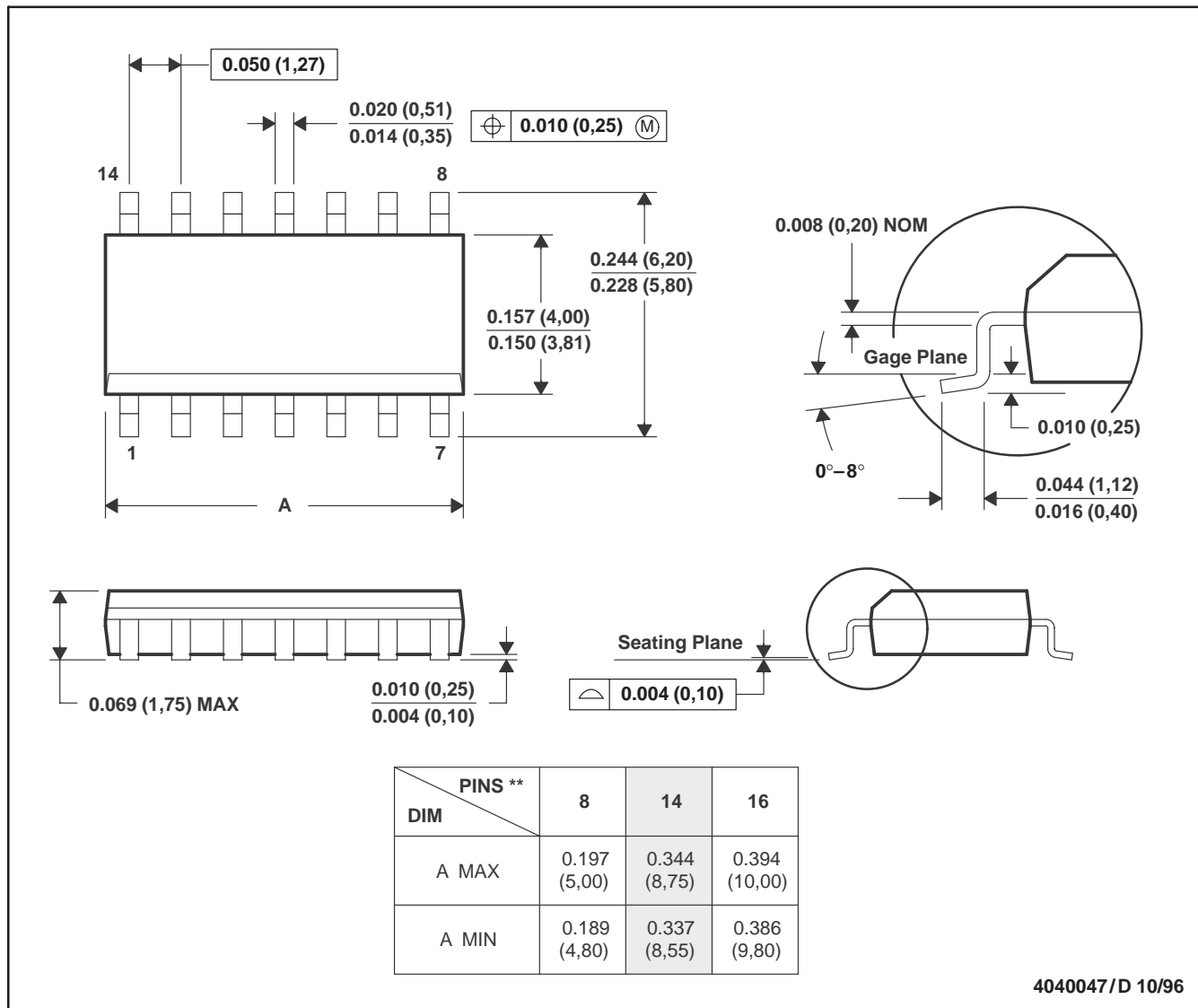

- NOTES: A. All linear dimensions are in inches (millimeters).
 B. This drawing is subject to change without notice.
 C. Body dimensions do not include mold flash or protrusion, not to exceed 0.006 (0,15).
 D. Falls within JEDEC MS-012

IMPORTANT NOTICE

Texas Instruments and its subsidiaries (TI) reserve the right to make changes to their products or to discontinue any product or service without notice, and advise customers to obtain the latest version of relevant information to verify, before placing orders, that information being relied on is current and complete. All products are sold subject to the terms and conditions of sale supplied at the time of order acknowledgement, including those pertaining to warranty, patent infringement, and limitation of liability.

TI warrants performance of its semiconductor products to the specifications applicable at the time of sale in accordance with TI's standard warranty. Testing and other quality control techniques are utilized to the extent TI deems necessary to support this warranty. Specific testing of all parameters of each device is not necessarily performed, except those mandated by government requirements.

CERTAIN APPLICATIONS USING SEMICONDUCTOR PRODUCTS MAY INVOLVE POTENTIAL RISKS OF DEATH, PERSONAL INJURY, OR SEVERE PROPERTY OR ENVIRONMENTAL DAMAGE ("CRITICAL APPLICATIONS"). TI SEMICONDUCTOR PRODUCTS ARE NOT DESIGNED, AUTHORIZED, OR WARRANTED TO BE SUITABLE FOR USE IN LIFE-SUPPORT DEVICES OR SYSTEMS OR OTHER CRITICAL APPLICATIONS. INCLUSION OF TI PRODUCTS IN SUCH APPLICATIONS IS UNDERSTOOD TO BE FULLY AT THE CUSTOMER'S RISK.

In order to minimize risks associated with the customer's applications, adequate design and operating safeguards must be provided by the customer to minimize inherent or procedural hazards.

TI assumes no liability for applications assistance or customer product design. TI does not warrant or represent that any license, either express or implied, is granted under any patent right, copyright, mask work right, or other intellectual property right of TI covering or relating to any combination, machine, or process in which such semiconductor products or services might be or are used. TI's publication of information regarding any third party's products or services does not constitute TI's approval, warranty or endorsement thereof.