

# uA9638C DUAL HIGH-SPEED DIFFERENTIAL LINE DRIVER

SLLS112C – OCTOBER 1980 – REVISED APRIL 1994

- Meets or Exceeds ANSI Standard EIA/TIA-422-B
- Operates From a Single 5-V Power Supply
- Drives Loads as Low as 50  $\Omega$  up to 15 Mbps
- TTL- and CMOS-Input Compatibility
- Output Short-Circuit Protection
- Interchangeable With National Semiconductor™ DS9638

D OR P PACKAGE  
(TOP VIEW)

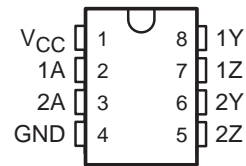

## description

The uA9638C is a dual high-speed differential line driver designed to meet ANSI Standard EIA/TIA-422-B. The inputs are TTL and CMOS compatible and have input clamp diodes. Schottky-diode-clamped transistors are used to minimize propagation delay time. This device operates from a single 5-V power supply and is supplied in an 8-pin package.

The uA9638 provides the current needed to drive low-impedance loads at high speeds. Typically used with twisted-pair cabling and differential receiver(s), base-band data transmission can be accomplished up to and exceeding 15 Mbps in properly designed systems. The uA9637A dual line receiver is commonly used as the receiver. For even faster switching speeds in the same pin configuration, see the SN75ALS191.

The uA9638C is characterized for operation from 0°C to 70°C.

## logic symbol†

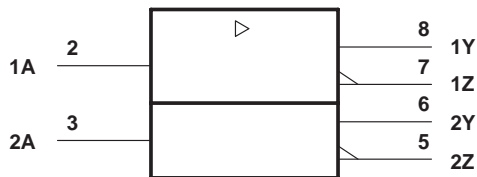

## logic diagram

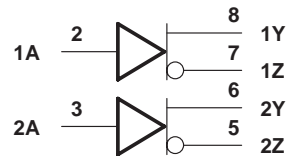

† This symbol is in accordance with ANSI/IEEE Std 91-1984 and IEC Publication 617-12.



Please be aware that an important notice concerning availability, standard warranty, and use in critical applications of Texas Instruments semiconductor products and disclaimers thereto appears at the end of this data sheet.

National Semiconductor is a trademark of National Semiconductor Corporation.

PRODUCTION DATA information is current as of publication date. Products conform to specifications per the terms of Texas Instruments standard warranty. Production processing does not necessarily include testing of all parameters.

**TEXAS  
INSTRUMENTS**

POST OFFICE BOX 655303 • DALLAS, TEXAS 75265

Copyright © 1994, Texas Instruments Incorporated

# uA9638C DUAL HIGH-SPEED DIFFERENTIAL LINE DRIVER

SLLS112C – OCTOBER 1980 – REVISED APRIL 1994

## schematics of inputs and outputs

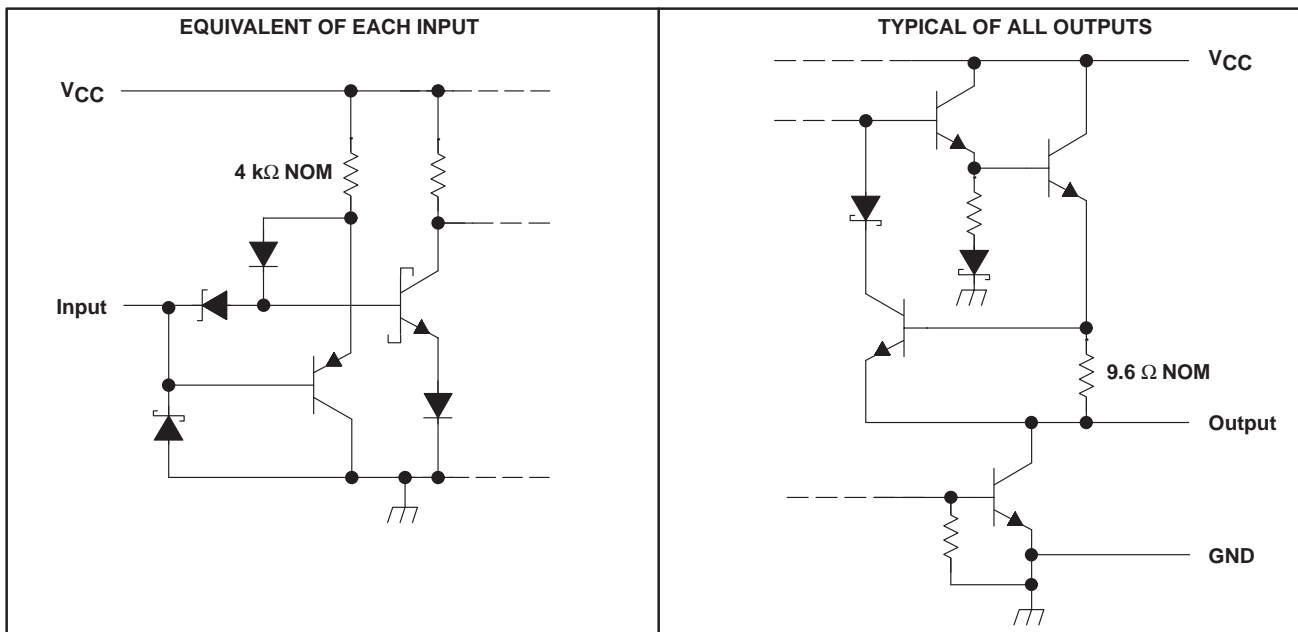

### absolute maximum ratings over operating free-air temperature range (unless otherwise noted)†

|   |       |                              |
|---|-------|------------------------------|
| Supply voltage range, $V_{CC}$ (see Note 1)         | ..... | -0.5 V to 7 V                |
| Input voltage range, $V_I$                          | ..... | -0.5 V to 7 V                |
| Continuous total power dissipation                  | ..... | See Dissipation Rating Table |
| Operating free-air temperature range, $T_A$         | ..... | 0°C to 70°C                  |
| Storage temperature range, $T_{stg}$                | ..... | -65°C to 150°C               |
| Lead temperature 1,6 mm (1/16 inch) from 10 seconds | ..... | 260°C                        |

† Stresses beyond those listed under “absolute maximum ratings” may cause permanent damage to the device. These are stress ratings only, and functional operation of the device at these or any other conditions beyond those indicated under “recommended operating conditions” is not implied. Exposure to absolute-maximum-rated conditions for extended periods may affect device reliability.

NOTE 1: Voltage values except differential output voltages are with respect to network GND.

DISSIPATION RATING TABLE

| PACKAGE | $T_A = 25^\circ\text{C}$<br>POWER RATING | DERATING FACTOR<br>ABOVE $T_A = 25^\circ\text{C}$ | $T_A = 70^\circ\text{C}$<br>POWER RATING |
|---------|--|---|--|
| D       | 725 mW                                   | 5.8 mW/°C   | 464 mW                                   |
| P       | 1000 mW                                  | 8.0 mW/°C   | 640 mW                                   |

### recommended operating conditions

|                                       | MIN  | NOM | MAX  | UNIT |
|---------------------------------------|------|-----|------|------|
| Supply voltage, $V_{CC}$              | 4.75 | 5   | 5.25 | V    |
| High-level input voltage, $V_{IH}$    | 2    |     |      | V    |
| Low-level input voltage, $V_{IL}$     |      |     | 0.8  | V    |
| High-level output current, $I_{OH}$   |      |     | -50  | mA   |
| Low-level output current, $I_{OL}$    |      |     | 50   | mA   |
| Operating free-air temperature, $T_A$ | 0    |     | 70   | °C   |



POST OFFICE BOX 655303 • DALLAS, TEXAS 75265

# uA9638C DUAL HIGH-SPEED DIFFERENTIAL LINE DRIVER

SLLS112C – OCTOBER 1980 – REVISED APRIL 1994

## electrical characteristics over operating free-air temperature range (unless otherwise noted)

| PARAMETER        |   | TEST CONDITIONS   |                                       | MIN       | TYP† | MAX        | UNIT          |   |
|------------------|---|---|---------------------------------------|-----------|------|------------|---------------|---|
| $V_{IK}$         | Input clamp voltage                                 | $V_{CC} = 4.75\text{ V}$ , $I_I = -18\text{ mA}$                              |                                       | -1        | -1.2 |            | V             |   |
| $V_{OH}$         | High-level output voltage                           | $V_{CC} = 4.75\text{ V}$ , $V_{IH} = 2\text{ V}$ ,<br>$V_{IL} = 0.8\text{ V}$ | $I_{OH} = -10\text{ mA}$              | 2.5       | 3.5  |            | V             |   |
|                  |   |   | $I_{OH} = -40\text{ mA}$              | 2         |      |            |               |   |
| $V_{OL}$         | Low-level output voltage                            | $V_{CC} = 4.75\text{ V}$ , $V_{IH} = 2\text{ V}$ ,<br>$I_{OL} = 40\text{ mA}$ | $V_{IL} = 0.8\text{ V}$ ,             |           |      | 0.5        | V             |   |
| $ V_{OD1} $      | Magnitude of differential output voltage            | $V_{CC} = 5.25\text{ V}$ , $I_O = 0$  |                                       |           |      | $2V_{OD2}$ | V             |   |
| $ V_{OD2} $      | Magnitude of differential output voltage            | $V_{CC} = 4.75\text{ V to } 5.25\text{ V}$ ,<br>See Figure 1                  |                                       | 2         |      |            | V             |   |
| $\Delta V_{OD} $ | Change in magnitude of differential output voltage‡ |   |                                       |           |      | $\pm 0.4$  | V             |   |
| $V_{OC}$         | Common-mode output voltage§                         |   |                                       |           |      | 3          |               | V |
| $\Delta V_{OC} $ | Change in magnitude of common-mode output voltage‡  |   |                                       |           |      | $\pm 0.4$  |               | V |
| $I_O$            | Output current with power off                       | $V_{CC} = 0$  | $V_O = 6\text{ V}$                    | 0.1       | 100  |            | $\mu\text{A}$ |   |
|                  |   |   | $V_O = -0.25\text{ V}$                | -0.1      | -100 |            |               |   |
|                  |   |   | $V_O = -0.25\text{ V to } 6\text{ V}$ | $\pm 100$ |      |            |               |   |
| $I_I$            | Input current                                       | $V_{CC} = 5.25\text{ V}$ , $V_I = 5.5\text{ V}$                               |                                       |           |      | 50         | $\mu\text{A}$ |   |
| $I_{IH}$         | High-level input current                            | $V_{CC} = 5.25\text{ V}$ , $V_I = 2.7\text{ V}$                               |                                       |           |      | 25         | $\mu\text{A}$ |   |
| $I_{IL}$         | Low-level input current                             | $V_{CC} = 5.25\text{ V}$ , $V_I = 0.5\text{ V}$                               |                                       |           |      | -200       | $\mu\text{A}$ |   |
| $I_{OS}$         | Short-circuit output current¶                       | $V_{CC} = 5.25\text{ V}$ , $V_O = 0$  |                                       | -50       |      | -150       | mA            |   |
| $I_{CC}$         | Supply current (both drivers)                       | $V_{CC} = 5.25\text{ V}$ , No load, All inputs at 0 V                         |                                       |           | 45   | 65         | mA            |   |

† All typical values are at  $V_{CC} = 5\text{ V}$  and  $T_A = 25^\circ\text{C}$ .

‡  $\Delta|V_{OD}|$  and  $\Delta|V_{OC}|$  are the changes in magnitude of  $V_{OD}$  and  $V_{OC}$ , respectively, that occur when the input is changed from a high level to a low level or vice versa.

§ In Standard EIA-422-A,  $V_{OC}$ , which is the average of the two output voltages with respect to ground, is called output offset voltage,  $V_{OS}$ .

¶ Only one output at a time should be shorted, and duration of the short circuit should not exceed one second.

## switching characteristics, $V_{CC} = 5\text{ V}$ , $T_A = 25^\circ\text{C}$

| PARAMETER        |                                     | TEST CONDITIONS  |  | MIN          | TYP | MAX | UNIT |
|------------------|-------------------------------------|--|--|--------------|-----|-----|------|
| $t_d(\text{OD})$ | Differential output delay time      | $C_L = 15\text{ pF}$ , $R_L = 100\ \Omega$ ,<br>See Figure 2 |  |              | 10  | 20  | ns   |
| $t_t(\text{OD})$ | Differential output transition time |  |  |              | 10  | 20  | ns   |
| $t_{sk(o)}$      | Output skew                         |  |  | See Figure 2 |     | 1   |      |



# uA9638C DUAL HIGH-SPEED DIFFERENTIAL LINE DRIVER

SLLS112C – OCTOBER 1980 – REVISED APRIL 1994

## PARAMETER MEASUREMENT INFORMATION

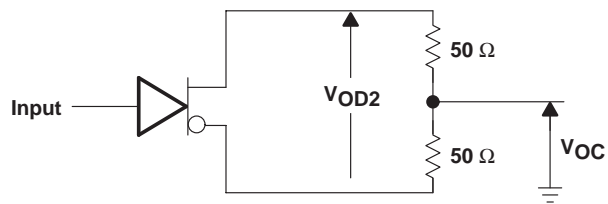
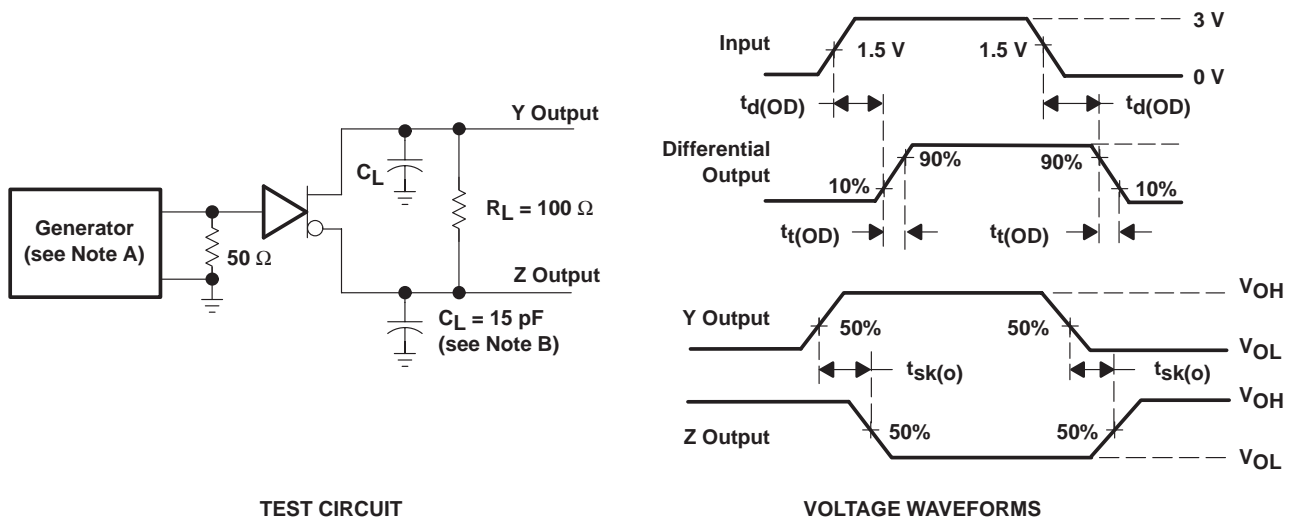

Figure 1. Differential and Common-Mode Output Voltages



### TEST CIRCUIT

### VOLTAGE WAVEFORMS

- NOTES: A. The input pulse generator has the following characteristics:  $Z_O = 50 \Omega$ ,  $PRR \leq 500 \text{ kHz}$ ,  $t_w = 100 \text{ ns}$ ,  $t_r = \leq 5 \text{ ns}$ .  
B.  $C_L$  includes probe and jig capacitance.

Figure 2. Test Circuit and Voltage Waveforms

## **IMPORTANT NOTICE**

Texas Instruments and its subsidiaries (TI) reserve the right to make changes to their products or to discontinue any product or service without notice, and advise customers to obtain the latest version of relevant information to verify, before placing orders, that information being relied on is current and complete. All products are sold subject to the terms and conditions of sale supplied at the time of order acknowledgement, including those pertaining to warranty, patent infringement, and limitation of liability.

TI warrants performance of its semiconductor products to the specifications applicable at the time of sale in accordance with TI's standard warranty. Testing and other quality control techniques are utilized to the extent TI deems necessary to support this warranty. Specific testing of all parameters of each device is not necessarily performed, except those mandated by government requirements.

**CERTAIN APPLICATIONS USING SEMICONDUCTOR PRODUCTS MAY INVOLVE POTENTIAL RISKS OF DEATH, PERSONAL INJURY, OR SEVERE PROPERTY OR ENVIRONMENTAL DAMAGE ("CRITICAL APPLICATIONS"). TI SEMICONDUCTOR PRODUCTS ARE NOT DESIGNED, AUTHORIZED, OR WARRANTED TO BE SUITABLE FOR USE IN LIFE-SUPPORT DEVICES OR SYSTEMS OR OTHER CRITICAL APPLICATIONS. INCLUSION OF TI PRODUCTS IN SUCH APPLICATIONS IS UNDERSTOOD TO BE FULLY AT THE CUSTOMER'S RISK.**

In order to minimize risks associated with the customer's applications, adequate design and operating safeguards must be provided by the customer to minimize inherent or procedural hazards.

TI assumes no liability for applications assistance or customer product design. TI does not warrant or represent that any license, either express or implied, is granted under any patent right, copyright, mask work right, or other intellectual property right of TI covering or relating to any combination, machine, or process in which such semiconductor products or services might be or are used. TI's publication of information regarding any third party's products or services does not constitute TI's approval, warranty or endorsement thereof.