

# SN65LBC031Q HIGH-SPEED CONTROLLER AREA NETWORK (CAN) TRANSCEIVERS

SLRS048B – MAY 1998 – REVISED MAY 2000

- **SN65LBC031Q Meets Standard ISO/DIS 11898 (up to 500 k Baud)**
- **Driver Output Capability at 50 mA**
- **Wide Positive and Negative Input/output Bus Voltage Range**
- **Bus Outputs Short-Circuit-Protected to Battery Voltage and Ground**
- **Thermal Shutdown**
- **Available in Q-Temp Automotive**
  - **High Reliability Automotive Applications**
  - **Configuration Control/Print Support**
  - **Qualification to Automotive Standards**

## description

The SN65LBC031Q is a CAN transceiver used as an interface between a CAN controller and the physical bus for high speed applications of up to 500 k Baud. The device provides transmit capability to the differential bus and differential receive capability to the controller. The transmitter outputs (CANH and CANL), feature internal transition regulation to provide controlled symmetry resulting in low EMI emissions. Both transmitter outputs are fully protected against battery short circuits and electrical transients that can occur on the bus lines. In the event of excessive device power dissipation the output drivers are disabled by the thermal shutdown circuitry at a junction temperature of approximately 160°C. The inclusion of an internal pullup resistor on the transmitter input ensures a defined output during power up and protocol controller reset. For normal operation at 500 k Baud the ASC terminal is open or tied to GND. For slower speed operation at 125 k Baud the bus output transition times can be increased to reduce EMI by connecting the ASC terminal to V<sub>CC</sub>. The receiver includes an integrated filter that suppresses the signal into pulses less than 30 ns wide.

The SN65LBC031Q is characterized for operation over the automotive temperature range of –40°C to 125°C.

**D PACKAGE  
(TOP VIEW)**

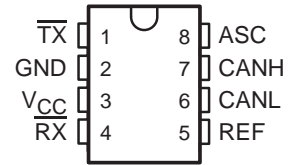

**TERMINAL FUNCTIONS**

TERMINAL	DESCRIPTION
$\overline{\text{TX}}$	Transmitter input
GND	Ground
V <sub>CC</sub>	Supply voltage
$\overline{\text{RX}}$	Receiver output
REF	Reference output
CANL	Low side bus output driver
CANH	High side bus output driver
ASC	Adjustable slope control

**FUNCTION TABLE**

$\overline{\text{TX}}$	CANH	CANL	BUS STATE	$\overline{\text{RX}}$
L	H	L	Dominant	L
High or floating	Floating	Floating	Recessive	H

L = low, H = high

## logic diagram

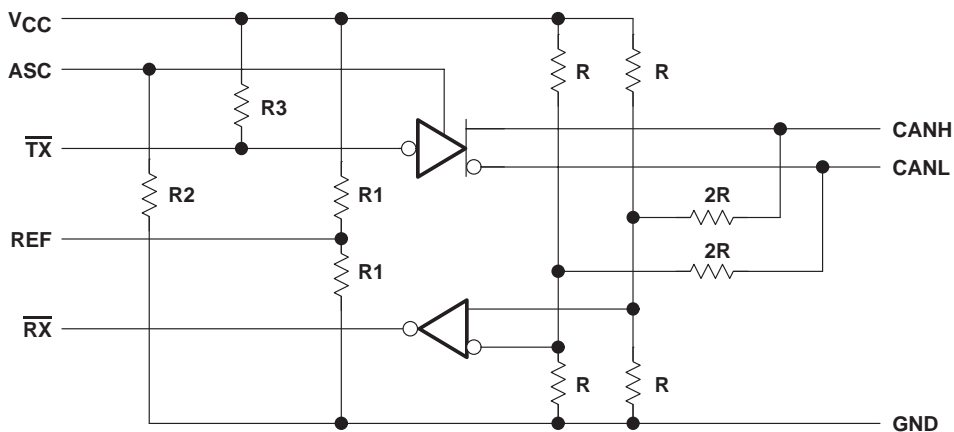

Please be aware that an important notice concerning availability, standard warranty, and use in critical applications of Texas Instruments semiconductor products and disclaimers thereto appears at the end of this data sheet.

PRODUCTION DATA information is current as of publication date. Products conform to specifications per the terms of Texas Instruments standard warranty. Production processing does not necessarily include testing of all parameters.

**TEXAS  
INSTRUMENTS**

POST OFFICE BOX 655303 • DALLAS, TEXAS 75265

Copyright © 2000, Texas Instruments Incorporated

# SN65LBC031Q HIGH-SPEED CONTROLLER AREA NETWORK (CAN) TRANSCEIVERS

SLRS048B – MAY 1998 – REVISED MAY 2000

## absolute maximum ratings over operating free-air temperature range (unless otherwise noted)†

Logic supply voltage, $V_{CC}$ (see Note 1)	7 V
Bus terminal voltage	-5 V to 20 V
Input current at $\overline{TX}$ and ASC terminal, $I_I$	$\pm 10$ mA
Input voltage at $\overline{TX}$ and ASC terminal, $V_I$	$2 \times V_{CC}$
Operating free-air temperature range, $T_A$	-40°C to 125°C
Operating junction temperature range, $T_J$	-40°C to 150°C
Continuous total power dissipation at (or below) 25°C free-air temperature	See Dissipation Rating Table
Storage temperature range, $T_{stg}$	-65°C to 150°C
Case temperature for 10 sec $T_C$ , D package	260°C

† Stresses beyond those listed under “absolute maximum ratings” may cause permanent damage to the device. These are stress ratings only, and functional operation of the device at these or any other conditions beyond those indicated under “recommended operating conditions” is not implied. Exposure to absolute-maximum-rated conditions for extended periods may affect device reliability.

NOTE 1: All voltage values, except differential bus voltage, are measured with respect to GND.

DISSIPATION RATING TABLE

PACKAGE	$T_A \leq 25^\circ\text{C}$ POWER RATING	OPERATING FACTOR ABOVE $T_C = 25^\circ\text{C}$	$T_C = 125^\circ\text{C}$ POWER RATING
D	725 mW	5.8 mW/°C	145 mW

DISSIPATION DERATING CURVE  
vs  
FREE-AIR TEMPERATURE

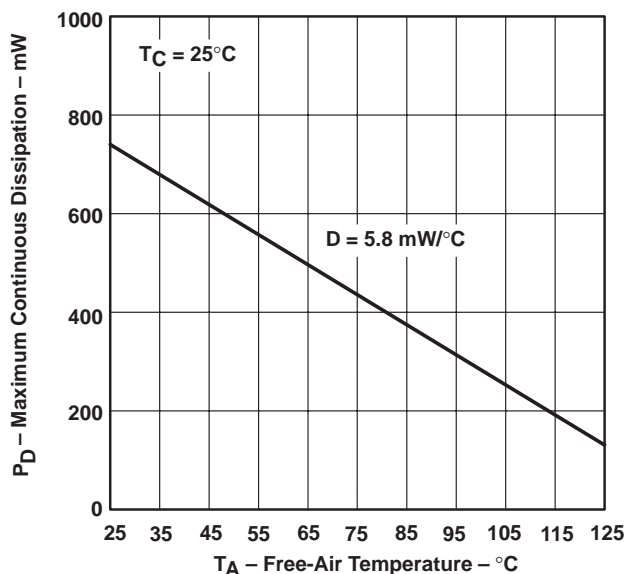

Figure 1



POST OFFICE BOX 655303 • DALLAS, TEXAS 75265

# SN65LBC031Q

## HIGH-SPEED CONTROLLER AREA NETWORK (CAN) TRANSCEIVERS

SLRS048B – MAY 1998 – REVISED MAY 2000

### recommended operating conditions

		MIN	NOM	MAX	UNIT
Logic supply voltage, $V_{CC}$		4.5	5	5.5	V
Voltage at any bus terminal (separately or common mode), $V_I$ or $V_{IC}$ (see Note 3)		-2		7	V
High-level input voltage, $V_{IH}$	$\overline{TX}$	2		$V_{CC}$	V
Low-level input voltage, $V_{IL}$	$\overline{TX}$	0		0.8	V
High-level output current, $I_{OH}$	Transmitter			-50	mA
	Receiver			-400	$\mu$ A
Low-level output current, $I_{OL}$	Transmitter			50	mA
	Receiver			1	
Operating free-air temperature, $T_A$		-40		125	$^{\circ}$ C

NOTES: 2. All voltage values, except differential bus voltage, are measured with respect to the ground terminal.

3. For bus voltages from -5 V to -2 V and 7 V to 20 V the receiver output is stable.

### SYMBOL DEFINITION

DATA SHEET PARAMETER	DEFINITION
$V_{O(CANHR)}$	CANH bus output voltage (recessive state)
$V_{O(CANLR)}$	CANL bus output voltage (recessive state)
$V_{O(CANHD)}$	CANH bus output voltage (dominant state)
$V_{O(CANLD)}$	CANL bus output voltage (dominant state)
$V_{O(DIFFR)}$	Bus differential output voltage (recessive state)
$V_{O(DIFFD)}$	Bus differential output voltage (dominant state)
$V_{I(ASC)}$	Adjustable slope control input voltage

### electrical characteristics over recommended ranges of supply voltage and operating free-air temperature (unless otherwise noted)

PARAMETER	TEST CONDITIONS	MIN	TYP	MAX	UNIT
$V_{O(REF)}$ Reference source output voltage	$I_{REF} = \pm 20 \mu A$	$0.45 V_{CC}$		$0.55 V_{CC}$	V
$R_{O(REF)}$ Reference source output resistance		5		10	k $\Omega$
$I_{CC(REC)}$ Logic supply current, recessive state	See Figure 2, S1 closed		12	20	mA
$I_{CC(DOM)}$ Logic supply current, dominant state			55	80	



# SN65LBC031Q

## HIGH-SPEED CONTROLLER AREA NETWORK (CAN) TRANSCEIVERS

SLRS048B – MAY 1998 – REVISED MAY 2000

### transmitter electrical characteristics over recommended ranges of supply and operating free-air temperature (unless otherwise noted)

PARAMETER		TEST CONDITIONS	MIN	TYP	MAX	UNIT
$V_{O(CANHR)}$	Output voltage (recessive state)	See Figure 2, S1 open	2	$0.5V_{CC}$	3	V
$V_{O(CANLR)}$						
$V_{O(DIFFR)}$	Differential output voltage (recessive state)		-500	0	50	mV
$V_{O(CANHD)}$	Output voltage (dominant state)	See Figure 2, S1 closed	2.75	3.5	4.5	V
$V_{O(CANLD)}$			0.5	1.5	2.25	
$V_{O(DIFFD)}$			1.5	2	3	
$V_{O(DIFFD)}$						
$I_{IH(TX)}$	High-level input current (TX)	$V_{IH} = 2.4\text{ V}$		-100	-185	$\mu\text{A}$
		$V_{IH} = V_{CC}$			$\pm 2$	
$I_{IH(ASC)}$	High-level input current (ASC)	$V_{IH} = 2.4\text{ V}$		100	165	$\mu\text{A}$
		$V_{IH} = V_{CC}$		200	340	
$I_{IL(TX)}$	Low-level input current ( $\overline{\text{TX}}$ )	$V_{IL} = 0.4\text{ V}$		-180	-400	$\mu\text{A}$
$I_{IL(ASC)}$	Low-level input current (ASC)	$V_{IL} = 0.4\text{ V}$		15	25	$\mu\text{A}$
$C_I(TX)$	$\overline{\text{TX}}$ input capacitance			8		pF
$I_{O(ssH)}$	CANH short circuit output current	$V_{O(CANH)} = -2\text{ V to } 20\text{ V}$		-95	-200	mA
$I_{O(ssL)}$	CANL short circuit output current	$V_{O(CANL)} = 20\text{ V to } -2\text{ V}$		140	250	mA

NOTE 2: All voltage values, except differential bus voltage, are measured with respect to the ground terminal.

### transceiver dynamic characteristics over recommended operating free-air temperature range and $V_{CC} = 5\text{ V}$

PARAMETER		TEST CONDITIONS	MIN	TYP	MAX	UNIT
$t_{(loop)}$	Loop time	See Figures 2 and 3, S1 closed, $V_I(ASC) = 0\text{ V}$ or open circuit, S2 open			280	ns
		See Figures 2 and 3, S1 closed, $V_I(ASC) = V_{CC}$ , S2 closed			400	ns
$SR_{(RD)}$	Differential-output slew rate (recessive to dominant)	See Figures 2 and 4, S1 closed, $V_I(ASC) = 0$ or open circuit, S2 open		35		V/ $\mu\text{s}$
		See Figures 2 and 4, S1 closed, $V_I(ASC) = V_{CC}$ , S2 closed		10		V/ $\mu\text{s}$
$SR_{(DR)}$	Differential-output slew rate (dominant to recessive)	See Figures 2 and 4, S1 closed, $V_I(ASC) = 0$ or open circuit, S2 open		10		V/ $\mu\text{s}$
		See Figures 2 and 4, S1 closed, $V_I(ASC) = V_{CC}$ , S2 closed		10		V/ $\mu\text{s}$
$t_{d(RD)}$	Differential-output delay time	See Figure 2, S1 closed		55		ns
$t_{d(DR)}$				160		ns
$t_{pd(RECRD)}$	Receiver propagation delay time	See Figures 2 and 5		90		ns
$t_{pd(RECDR)}$				55		ns

NOTE 4: Receiver input pulse width should be >50 ns. Input pulses of <30 ns are suppressed.



POST OFFICE BOX 655303 • DALLAS, TEXAS 75265

# SN65LBC031Q

## HIGH-SPEED CONTROLLER AREA NETWORK (CAN) TRANSCEIVERS

SLRS048B – MAY 1998 – REVISED MAY 2000

receiver electrical characteristics over recommended ranges of common-mode input voltage, supply voltage, and operating free-air temperature (unless otherwise noted)

PARAMETER		TEST CONDITIONS	MIN	TYP	MAX	UNIT
$V_{IT(REC)}$	Differential input threshold voltage for recessive state	$V_{IC} = -2\text{ V to }7\text{ V}$			500	mV
$V_{IT(DOM)}$	Differential input threshold voltage for dominant state		900			
$V_{hys}$	Recessive-dominant input hysteresis		100	180		mV
$V_{OH(RX)}$	High-level output voltage	$V_{O(DIFF)} = 500\text{ mV}$ , $I_{OH} = -400\text{ }\mu\text{A}$	$V_{CC} - 0.5\text{ V}$		$V_{CC}$	V
$V_{OL(RX)}$	Low-level output voltage	$V_{O(DIFF)} = 900\text{ mV}$ , $I_{OL} = 1\text{ mA}$	0		0.5	V
$r_{I(REC)}$	CANH and CANL input resistance in recessive state	dc, no load	5		50	k $\Omega$
$r_{I(DIFF)}$	Differential CANH and CANL input resistance in recessive state	dc, no load	10		100	k $\Omega$
$C_i$	CANH and CANL input capacitance			20		pF
$C_{i(DHL)}$	Differential CANH and CANL input capacitance			10		pF

NOTE 2: All voltage values, except differential bus voltage, are measured with respect to the ground terminal.

### PARAMETER MEASUREMENT INFORMATION

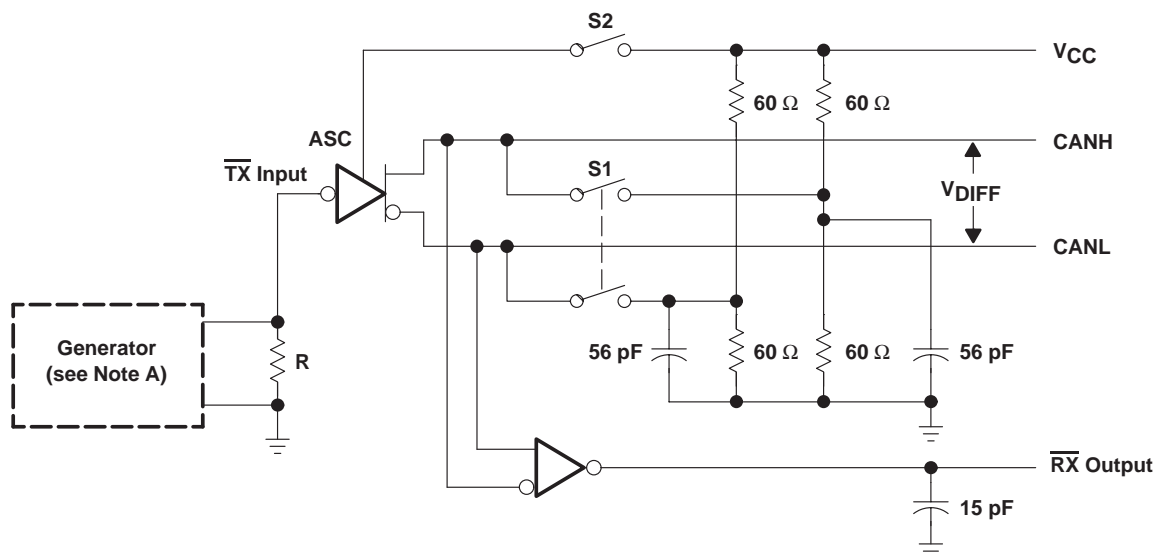

NOTE A: The input pulse is supplied to  $\overline{\text{TX}}$  by a generator having a  $t_r$  and  $t_f = 5\text{ ns}$ .

**Figure 2. Test Circuit**

# SN65LBC031Q HIGH-SPEED CONTROLLER AREA NETWORK (CAN) TRANSCEIVERS

SLRS048B – MAY 1998 – REVISED MAY 2000

## PARAMETER MEASUREMENT INFORMATION

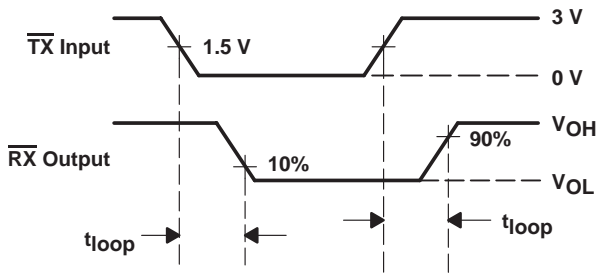

Figure 3. Loop Time

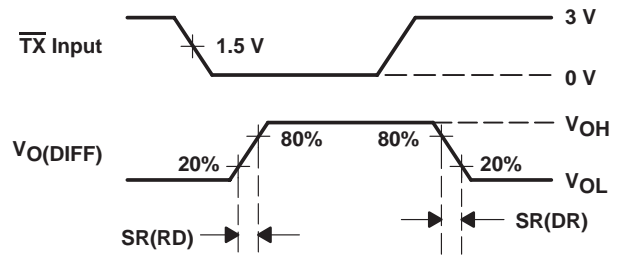
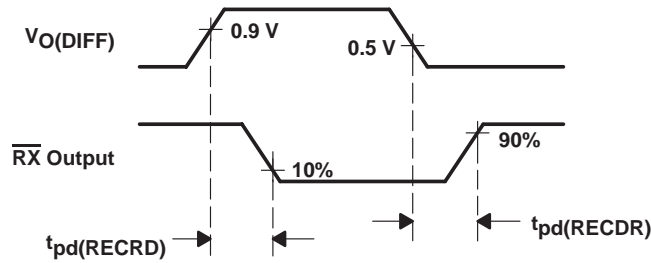

Figure 4. Slew Rate

NOTE A: The input pulse is supplied to  $\overline{\text{TX}}$  by a generator having a  $t_r$  and  $t_f = 5$  ns.



NOTE A: The input pulse is supplied as  $V_{\text{DIFF}}$  using CANH and CANL respectively by a generator having a  $t_r$  and  $t_f = 5$  ns.

Figure 5. Receiver Delay Times

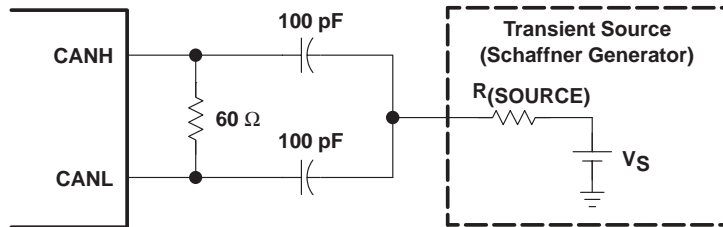
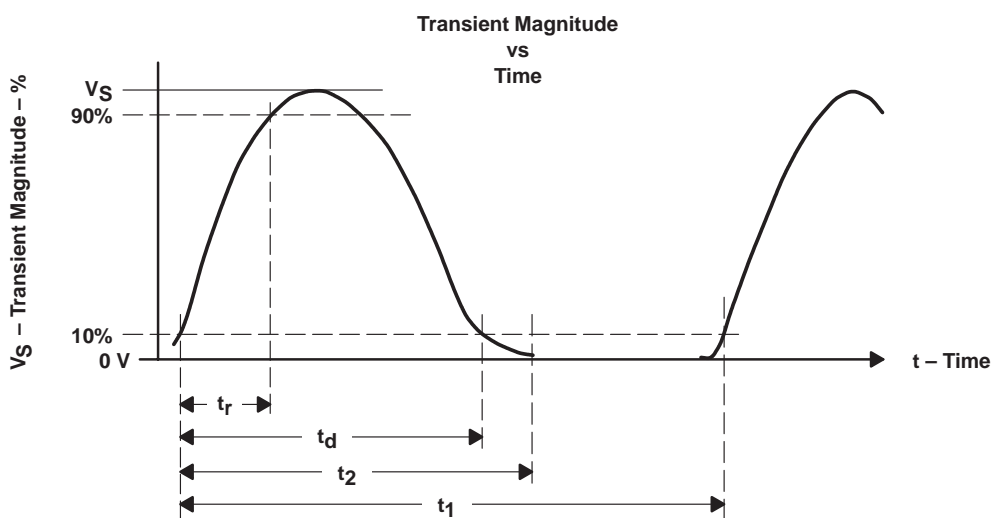

Figure 6. Transient Stress Capability Test Circuit

**PARAMETER MEASUREMENT INFORMATION**



**Figure 7. Transient Stress Capability Waveform**

**Table 1. Test Circuit Results According to DIN 40839**

TEST PULSE	TRANSIENT MAGNITUDE $V_S$	SOURCE IMPEDANCE $R_{SOURCE}$	PULSE WIDTH $t_d$ (see Note 5)	PULSE RISE TIME, $t_r$ (see Note 6)	PULSE TIME, $t_2$ (see Figure 7)	REPETITION PERIOD, $t_1$ (see Figure 7)	NUMBER OF PULSES
1	-100 V	10 $\Omega$	2 ms	1 $\mu$ s	200 ms	5 s	5000
2	100 V	10 $\Omega$	50 $\mu$ s	1 $\mu$ s	200 ms	5 s	5000
3a	-150 V	50 $\Omega$	0.1 $\mu$ s	5 ns	100 $\mu$ s	100 $\mu$ s	See Note 7
3b	100 V	50 $\Omega$	0.1 $\mu$ s	5 ns	100 $\mu$ s	100 $\mu$ s	See Note 7
5	60 V	1 $\Omega$	400 ms	5 ms	—	—	1

NOTES: 5. Measured from 10% on rising edge to 10% on falling edge  
 6. Measured from 10% to 90% of pulse  
 7. Pulse package for a period of 3600 s, 10 ms pulse time, 90 ms stop time

# SN65LBC031Q HIGH-SPEED CONTROLLER AREA NETWORK (CAN) TRANSCEIVERS

SLRS048B – MAY 1998 – REVISED MAY 2000

## APPLICATION INFORMATION

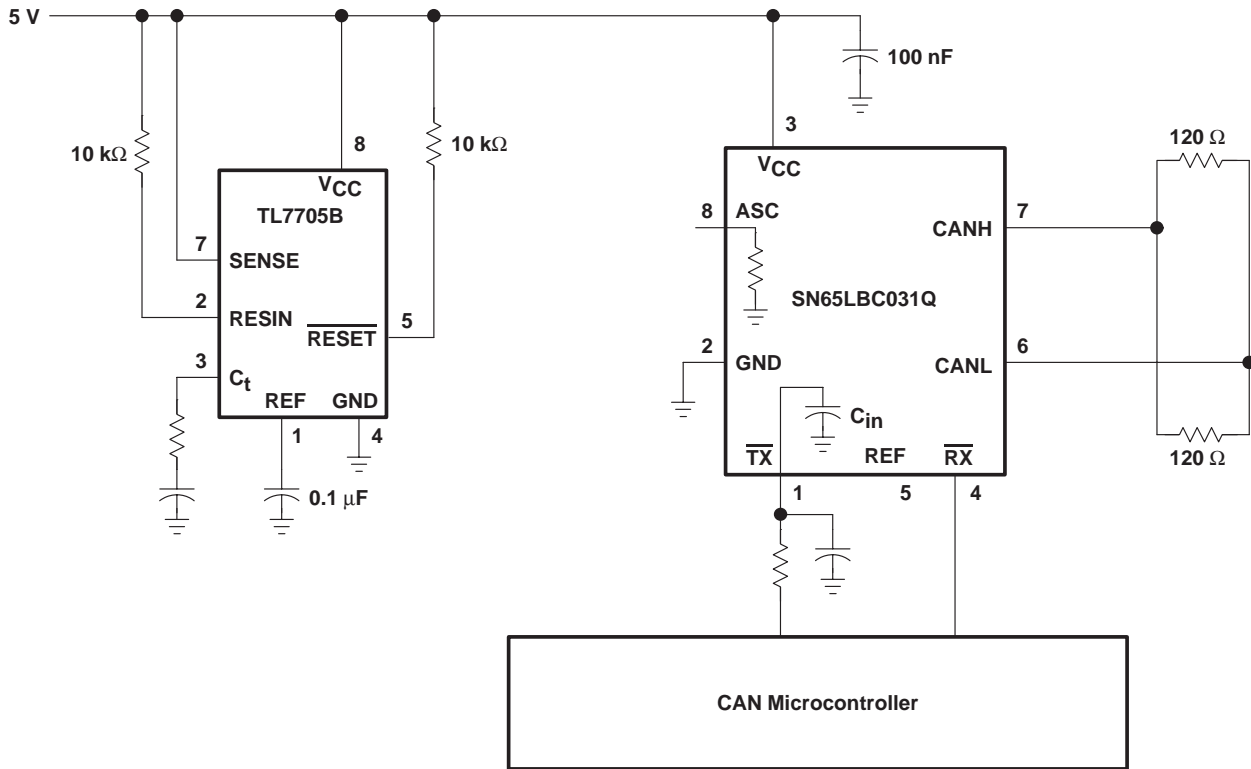

Figure 8. Typical SN65LBC031Q Application



# SN65LBC031Q HIGH-SPEED CONTROLLER AREA NETWORK (CAN) TRANSCEIVERS

SLRS048B – MAY 1998 – REVISED MAY 2000

## MECHANICAL DATA

**D (R-PDSO-G\*\*)**

**PLASTIC SMALL-OUTLINE PACKAGE**

14 PIN SHOWN

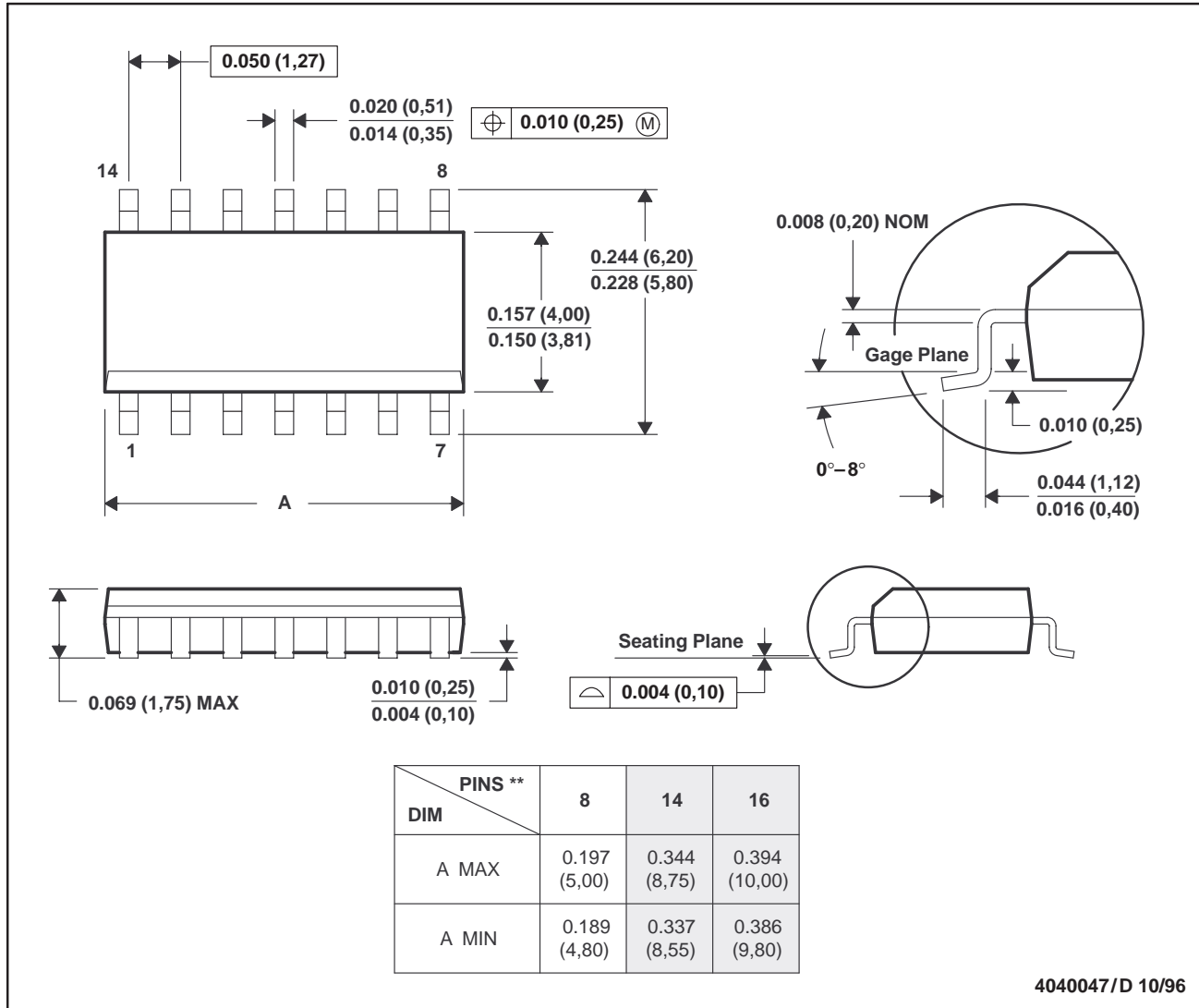

- NOTES: A. All linear dimensions are in inches (millimeters).  
 B. This drawing is subject to change without notice.  
 C. Body dimensions do not include mold flash or protrusion, not to exceed 0.006 (0,15).  
 D. Falls within JEDEC MS-012

## **IMPORTANT NOTICE**

Texas Instruments and its subsidiaries (TI) reserve the right to make changes to their products or to discontinue any product or service without notice, and advise customers to obtain the latest version of relevant information to verify, before placing orders, that information being relied on is current and complete. All products are sold subject to the terms and conditions of sale supplied at the time of order acknowledgment, including those pertaining to warranty, patent infringement, and limitation of liability.

TI warrants performance of its semiconductor products to the specifications applicable at the time of sale in accordance with TI's standard warranty. Testing and other quality control techniques are utilized to the extent TI deems necessary to support this warranty. Specific testing of all parameters of each device is not necessarily performed, except those mandated by government requirements.

Customers are responsible for their applications using TI components.

In order to minimize risks associated with the customer's applications, adequate design and operating safeguards must be provided by the customer to minimize inherent or procedural hazards.

TI assumes no liability for applications assistance or customer product design. TI does not warrant or represent that any license, either express or implied, is granted under any patent right, copyright, mask work right, or other intellectual property right of TI covering or relating to any combination, machine, or process in which such semiconductor products or services might be or are used. TI's publication of information regarding any third party's products or services does not constitute TI's approval, warranty or endorsement thereof.