

SN5446A, '47A, '48, SN54LS47, 'LS48, 'LS49
 SN7446A, '47A, '48, SN74LS47, 'LS48, 'LS49
 BCD-TO-SEVEN-SEGMENT DECODERS/DRIVERS
 SDLS111 – MARCH 1974 – REVISED MARCH 1988

'46A, '47A, 'LS47
 feature

- Open-Collector Outputs Drive Indicators Directly
- Lamp-Test Provision
- Leading/Trailing Zero Suppression

'48, 'LS48
 feature

- Internal Pull-Ups Eliminate Need for External Resistors
- Lamp-Test Provision
- Leading/Trailing Zero Suppression

'LS49
 feature

- Open-Collector Outputs
- Blanking Input

SN5446A, SN5447A, SN54LS47, SN5448,
 SN54LS48 . . . J PACKAGE
 SN7446A, SN7447A,
 SN7448 . . . N PACKAGE
 SN74LS47, SN74LS48 . . . D OR N PACKAGE

(TOP VIEW)

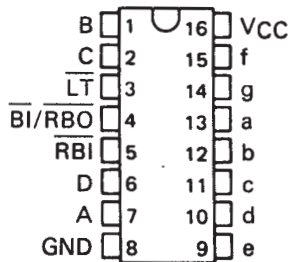

SN54LS47, SN54LS48 . . . FK PACKAGE
 (TOP VIEW)

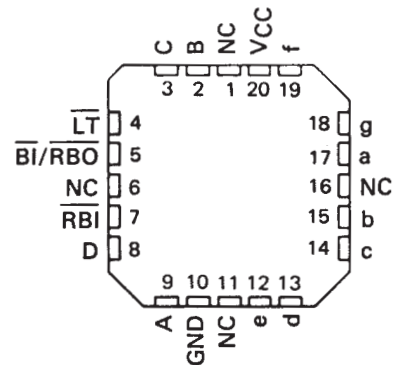

SN54LS49 . . . J OR W PACKAGE
 SN74LS49 . . . D OR N PACKAGE

(TOP VIEW)

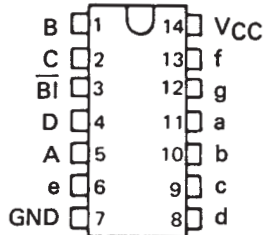

SN54LS49 . . . FK PACKAGE
 (TOP VIEW)

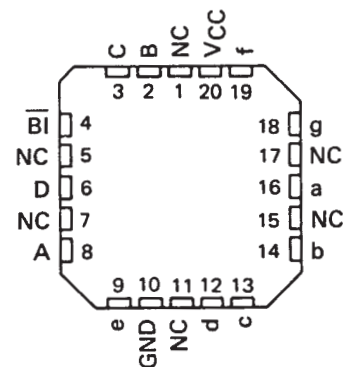

NC – No internal connection

PRODUCTION DATA information is current as of publication date. Products conform to specifications per the terms of Texas Instruments standard warranty. Production processing does not necessarily include testing of all parameters.

 **TEXAS
 INSTRUMENTS**

POST OFFICE BOX 655303 • DALLAS, TEXAS 75265

Copyright © 1988, Texas Instruments Incorporated

SN5446A, '47A, '48, SN54LS47, 'LS48, 'LS49
 SN7446A, '47A, '48, SN74LS47, 'LS48, 'LS49
 BCD-TO-SEVEN-SEGMENT DECODERS/DRIVERS

SDLS111 – MARCH 1974 – REVISED MARCH 1988

- All Circuit Types Feature Lamp Intensity Modulation Capability

TYPE	DRIVER OUTPUTS				TYPICAL POWER DISSIPATION	PACKAGES
	ACTIVE LEVEL	OUTPUT CONFIGURATION	SINK CURRENT	MAX VOLTAGE		
SN5446A	low	open-collector	40 mA	30 V	320 mW	J, W
SN5447A	low	open-collector	40 mA	15 V	320 mW	J, W
SN5448	high	2-kΩ pull-up	6.4 mA	5.5 V	265 mW	J,W
SN54LS47	low	open-collector	12 mA	15 V	35 mW	J, W
SN54LS48	high	2-kΩ pull-up	2 mA	5.5 V	125 mW	J, W
SN54LS49	high	open-collector	4 mA	5.5 V	40 mW	J, W
SN7446A	low	open-collector	40 mA	30 V	320 mW	J, N
SN7447A	low	open-collector	40 mA	15 V	320 mW	J, N
SN7448	high	2-kΩ pull-up	6.4 mA	5.5 V	265 mW	J, N
SN74LS47	low	open-collector	24 mA	15 V	35 mW	J, N
SN74LS48	high	2-kΩ pull-up	6 mA	5.5 V	125 mW	J, N
SN74LS49	high	open-collector	8 mA	5.5 V	40 mW	J, N

logic symbols†

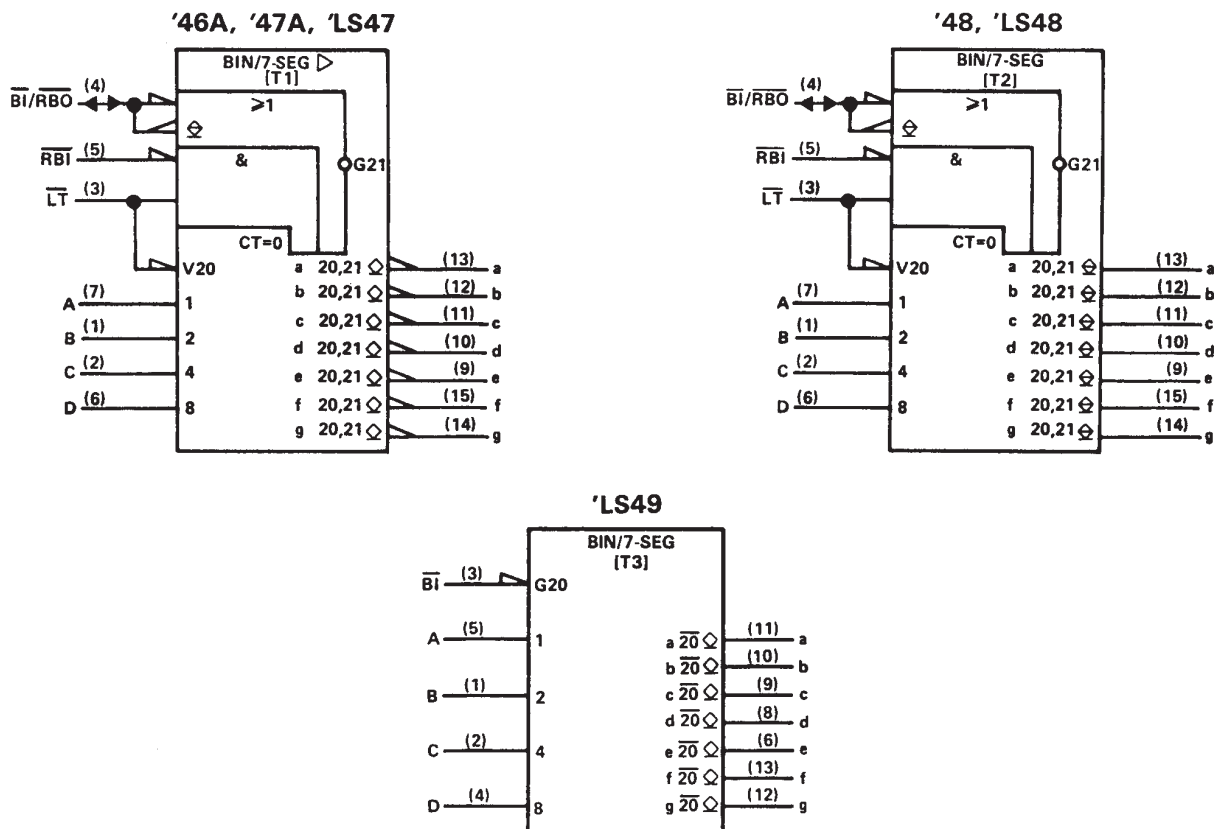

†These symbols are in accordance with ANSI/IEEE Std 91-1984 and IEC Publication 617-12. Pin numbers shown are for D, J, N, and W packages.



SN5446A, '47A, '48, SN54LS47, 'LS48, 'LS49 SN7446A, '47A, '48, SN74LS47, 'LS48, 'LS49 BCD-TO-SEVEN-SEGMENT DECODERS/DRIVERS

SDLS111 – MARCH 1974 – REVISED MARCH 1988

description

The '46A, '47A, and 'LS47 feature active-low outputs designed for driving common-anode LEDs or incandescent indicators directly. The '48, 'LS48, and 'LS49 feature active-high outputs for driving lamp buffers or common-cathode LEDs. All of the circuits except 'LS49 have full ripple-blanking input/output controls and a lamp test input. The 'LS49 circuit incorporates a direct blanking input. Segment identification and resultant displays are shown below. Display patterns for BCD input counts above 9 are unique symbols to authenticate input conditions.

The '46A, '47A, '48, 'LS47, and 'LS48 circuits incorporate automatic leading and/or trailing-edge zero-blanking control ($\overline{\text{RBI}}$ and $\overline{\text{RBO}}$). Lamp test ($\overline{\text{LT}}$) of these types may be performed at any time when the $\overline{\text{BI/RBO}}$ node is at a high level. All types (including the '49 and 'LS49) contain an overriding blanking input ($\overline{\text{BI}}$), which can be used to control the lamp intensity by pulsing or to inhibit the outputs. Inputs and outputs are entirely compatible for use with TTL logic outputs.

The SN54246/SN74246 and '247 and the SN54LS247/SN74LS247 and 'LS248 compose the $\overline{6}$ and the $\overline{9}$ with tails and were designed to offer the designer a choice between two indicator fonts.

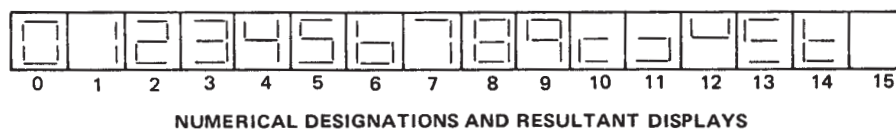
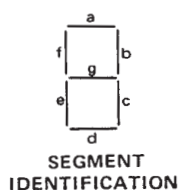

'46A, '47A, 'LS47 FUNCTION TABLE (T1)

DECIMAL OR FUNCTION	INPUTS						$\overline{\text{BI/RBO}}^\dagger$	OUTPUTS							NOTE	
	$\overline{\text{LT}}$	$\overline{\text{RBI}}$	D	C	B	A		a	b	c	d	e	f	g		
0	H	H	L	L	L	L	H	ON	ON	ON	ON	ON	ON	OFF	OFF	
1	H	X	L	L	L	H	H	OFF	ON	ON	OFF	OFF	OFF	OFF	OFF	
2	H	X	L	L	H	L	H	ON	ON	OFF	ON	ON	OFF	ON	ON	
3	H	X	L	L	H	H	H	ON	ON	ON	ON	OFF	OFF	ON	ON	
4	H	X	L	H	L	L	H	OFF	ON	ON	OFF	OFF	ON	ON	ON	
5	H	X	L	H	L	H	H	ON	OFF	ON	ON	OFF	ON	ON	ON	
6	H	X	L	H	H	L	H	OFF	OFF	ON	ON	ON	ON	ON	ON	
7	H	X	L	H	H	H	H	ON	ON	ON	OFF	OFF	OFF	OFF	OFF	
8	H	X	H	L	L	L	H	ON	ON	ON	ON	ON	ON	ON	ON	
9	H	X	H	L	L	H	H	ON	ON	ON	OFF	OFF	ON	ON	ON	
10	H	X	H	L	H	L	H	OFF	OFF	OFF	ON	ON	OFF	ON	ON	
11	H	X	H	L	H	H	H	OFF	OFF	ON	ON	OFF	OFF	ON	ON	
12	H	X	H	H	L	L	H	OFF	ON	OFF	OFF	OFF	ON	ON	ON	
13	H	X	H	H	L	H	H	ON	OFF	OFF	ON	OFF	ON	ON	ON	
14	H	X	H	H	H	L	H	OFF	OFF	OFF	ON	ON	ON	ON	ON	
15	H	X	H	H	H	H	H	OFF	OFF	OFF	OFF	OFF	OFF	OFF	OFF	
$\overline{\text{BI}}$	X	X	X	X	X	X	L	OFF	OFF	OFF	OFF	OFF	OFF	OFF	OFF	2
$\overline{\text{RBI}}$	H	L	L	L	L	L	L	OFF	OFF	OFF	OFF	OFF	OFF	OFF	OFF	3
$\overline{\text{LT}}$	L	X	X	X	X	X	H	ON	ON	ON	ON	ON	ON	ON	ON	4

H = high level, L = low level, X = irrelevant

- NOTES: 1. The blanking input ($\overline{\text{BI}}$) must be open or held at a high logic level when output functions 0 through 15 are desired. The ripple-blanking input ($\overline{\text{RBI}}$) must be open or high if blanking of a decimal zero is not desired.
2. When a low logic level is applied directly to the blanking input ($\overline{\text{BI}}$), all segment outputs are off regardless of the level of any other input.
3. When ripple-blanking input ($\overline{\text{RBI}}$) and inputs A, B, C, and D are at a low level with the lamp test input high, all segment outputs go off and the ripple-blanking output ($\overline{\text{RBO}}$) goes to a low level (response condition).
4. When the blanking input/ripple blanking output ($\overline{\text{BI/RBO}}$) is open or held high and a low is applied to the lamp-test input, all segment outputs are on.

¹ $\overline{\text{BI/RBO}}$ is wire AND logic serving as blanking input ($\overline{\text{BI}}$) and/or ripple-blanking output ($\overline{\text{RBO}}$).



SN5446A, '47A, '48, SN54LS47, 'LS48, 'LS49
 SN7446A, '47A, '48, SN74LS47, 'LS48, 'LS49
 BCD-TO-SEVEN-SEGMENT DECODERS/DRIVERS
 SDLS111 – MARCH 1974 – REVISED MARCH 1988

'48, 'LS48
 FUNCTION TABLE (T2)

DECIMAL OR FUNCTION	INPUTS						$\overline{\text{BI}}/\overline{\text{RBO}}^\dagger$	OUTPUTS							NOTE
	$\overline{\text{LT}}$	$\overline{\text{RBI}}$	D	C	B	A		a	b	c	d	e	f	g	
0	H	H	L	L	L	L	H	H	H	H	H	H	L		
1	H	X	L	L	L	H	H	L	H	H	L	L	L		
2	H	X	L	L	H	L	H	H	H	L	H	H	L		
3	H	X	L	L	H	H	H	H	H	H	L	L	H		
4	H	X	L	H	L	L	H	L	H	H	L	L	H		
5	H	X	L	H	L	H	H	H	L	H	L	L	H		
6	H	X	L	H	H	L	H	L	L	H	H	H	H		
7	H	X	L	H	H	H	H	H	H	H	L	L	L		
8	H	X	H	L	L	L	H	H	H	H	H	H	H		
9	H	X	H	L	L	H	H	H	H	H	L	L	H		
10	H	X	H	L	H	L	H	L	L	L	H	H	L		
11	H	X	H	L	H	H	H	L	L	H	H	L	L		
12	H	X	H	H	L	L	H	L	H	L	L	L	H		
13	H	X	H	H	L	H	H	H	L	L	L	H	H		
14	H	X	H	H	H	L	H	L	L	L	H	H	H		
15	H	X	H	H	H	H	H	L	L	L	L	L	L		
BI	X	X	X	X	X	X	L	L	L	L	L	L	L		
RBI	H	L	L	L	L	L	L	L	L	L	L	L	L		
LT	L	X	X	X	X	X	H	H	H	H	H	H	H		

H = high level, L = low level, X = irrelevant

- NOTES: 1. The blanking input ($\overline{\text{BI}}$) must be open or held at a high logic level when output functions 0 through 15 are desired. The ripple-blanking input ($\overline{\text{RBI}}$) must be open or high, if blanking of a decimal zero is not desired.
 2. When a low logic level is applied directly to the blanking input ($\overline{\text{BI}}$), all segment outputs are low regardless of the level of any other input.
 3. When ripple-blanking input ($\overline{\text{RBI}}$) and inputs A, B, C, and D are at a low level with the lamp-test input high, all segment outputs go low and the ripple-blanking output ($\overline{\text{RBO}}$) goes to a low level (response condition).
 4. When the blanking input/ripple-blanking output ($\overline{\text{BI}}/\overline{\text{RBO}}$) is open or held high and a low is applied to the lamp-test input, all segment outputs are high.

$^\dagger \overline{\text{BI}}/\overline{\text{RBO}}$ is wire-AND logic serving as blanking input ($\overline{\text{BI}}$) and/or ripple-blanking output ($\overline{\text{RBO}}$).

'LS49
 FUNCTION TABLE (T3)

DECIMAL OR FUNCTION	INPUTS					$\overline{\text{BI}}$	OUTPUTS							NOTE
	D	C	B	A	a		b	c	d	e	f	g		
0	L	L	L	L	L	H	H	H	H	H	H	L		
1	L	L	L	H	L	H	L	H	H	L	L	L		
2	L	L	H	L	L	H	H	H	L	H	H	L		
3	L	L	H	H	L	H	H	H	H	H	L	L		
4	L	H	L	L	L	H	L	H	H	L	L	H		
5	L	H	L	H	L	H	H	L	H	H	L	H		
6	L	H	H	L	L	H	L	L	H	H	H	H		
7	L	H	H	H	L	H	H	H	H	L	L	L		
8	H	L	L	L	L	H	H	H	H	H	H	H		
9	H	L	L	H	L	H	H	H	H	L	L	H		
10	H	L	H	L	L	H	L	L	L	H	H	L		
11	H	L	H	H	L	H	L	L	H	H	L	L		
12	H	H	L	L	L	H	L	H	L	L	L	H		
13	H	H	L	H	L	H	H	L	L	L	H	H		
14	H	H	H	L	L	H	L	L	L	H	H	H		
15	H	H	H	H	L	H	L	L	L	L	L	L		
BI	X	X	X	X	X	L	L	L	L	L	L	L		

H = high level, L = low level, X = irrelevant

- NOTES: 1. The blanking input ($\overline{\text{BI}}$) must be open or held at a high logic level when output functions 0 through 15 are desired.
 2. When a low logic level is applied directly to the blanking input ($\overline{\text{BI}}$), all segment outputs are low regardless of the level of any other input.



SN5446A, '47A, '48, SN54LS47, 'LS48, 'LS49
 SN7446A, '47A, '48, SN74LS47, 'LS48, 'LS49
 BCD-TO-SEVEN-SEGMENT DECODERS/DRIVERS
 SDLS111 - MARCH 1974 - REVISED MARCH 1988

logic diagrams (positive logic)

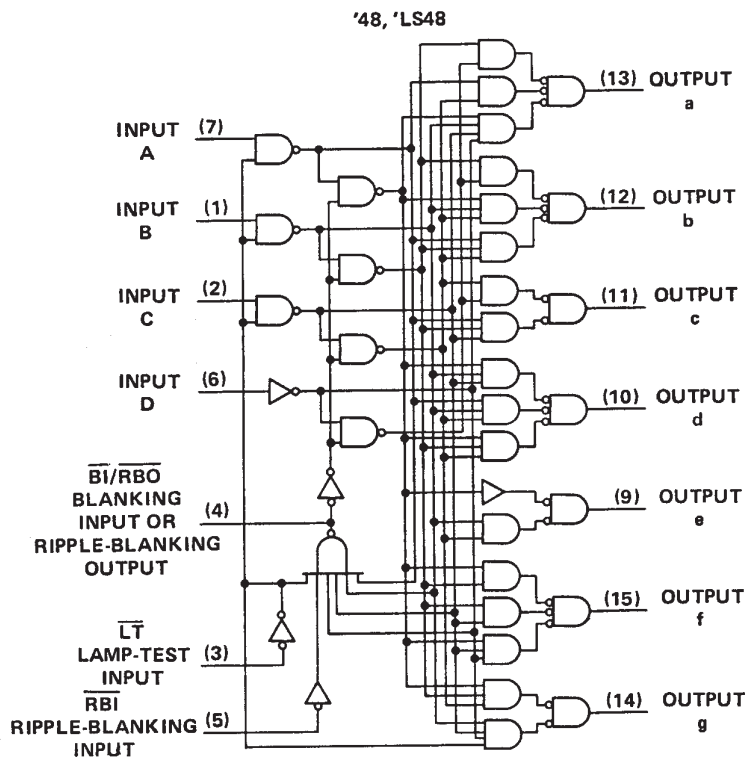
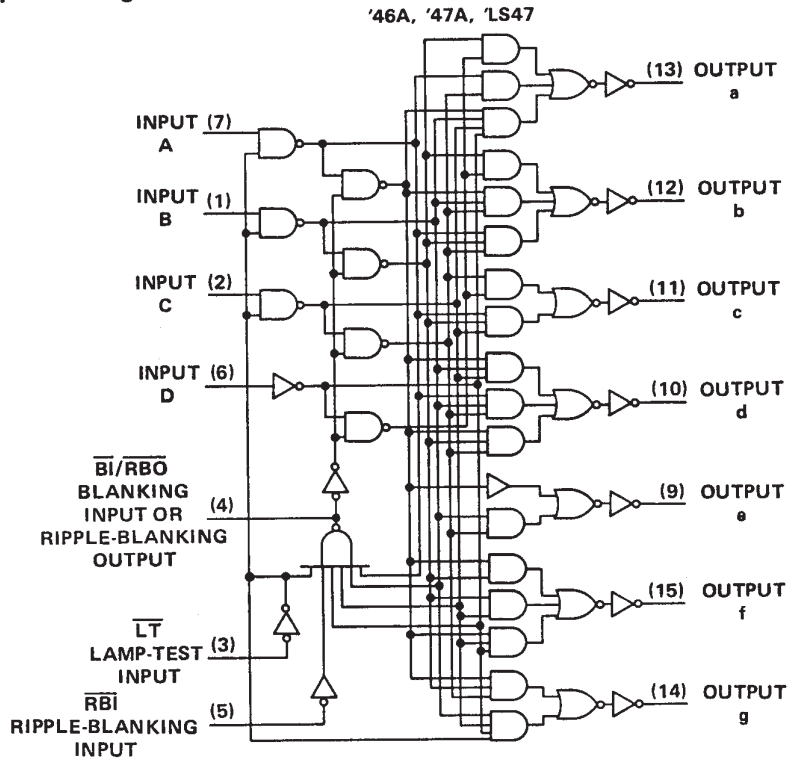

Pin numbers shown are for D, J, N, and W packages.



POST OFFICE BOX 655303 • DALLAS, TEXAS 75265

SN5446A, '47A, '48, SN54LS47, 'LS48, 'LS49
 SN7446A, '47A, '48, SN74LS47, 'LS48, 'LS49
 BCD-TO-SEVEN-SEGMENT DECODERS/DRIVERS

SDLS111 – MARCH 1974 – REVISED MARCH 1988

logic diagrams (continued)

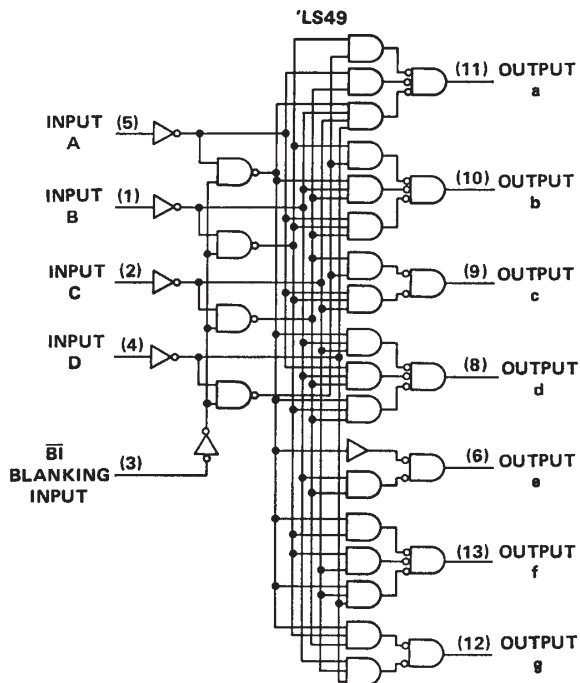

Pin numbers shown are for D, J, N, and W packages.

SN5446A, '47A, '48, SN54LS47, 'LS48, 'LS49
 SN7446A, '47A, '48, SN74LS47, 'LS48, 'LS49
 BCD-TO-SEVEN-SEGMENT DECODERS/DRIVERS
 SDLS111 - MARCH 1974 - REVISED MARCH 1988

schematics of inputs and outputs

'46A, '47A, '48

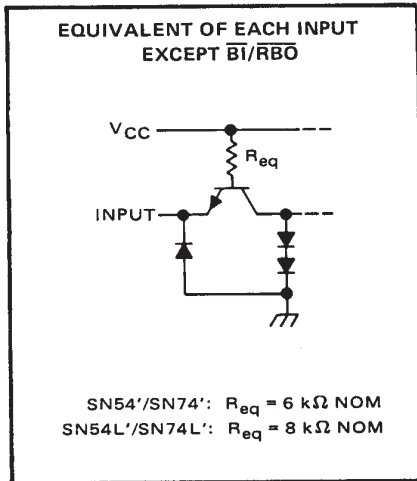

'46A, '47A, '48

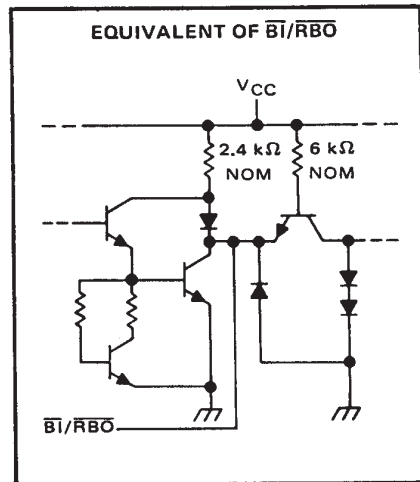

'46A, '47A

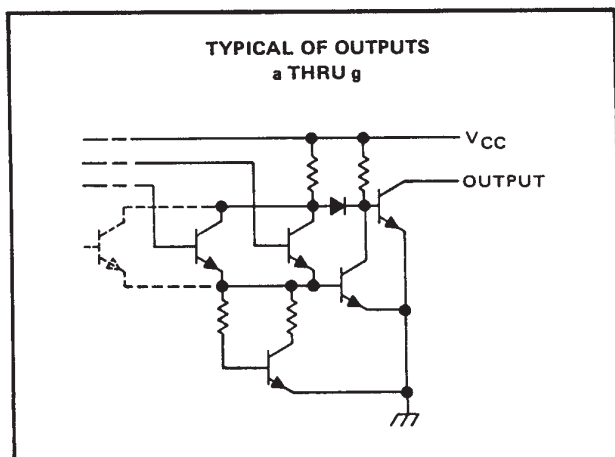

'48

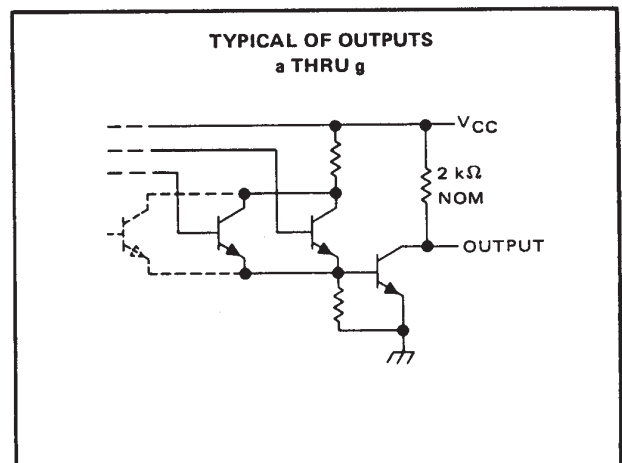

SN5446A, '47A, '48, SN54LS47, 'LS48, 'LS49
 SN7446A, '47A, '48, SN74LS47, 'LS48, 'LS49
 BCD-TO-SEVEN-SEGMENT DECODERS/DRIVERS

SDLS111 – MARCH 1974 – REVISED MARCH 1988

schematics of inputs and outputs

'LS47, 'LS48, 'LS49

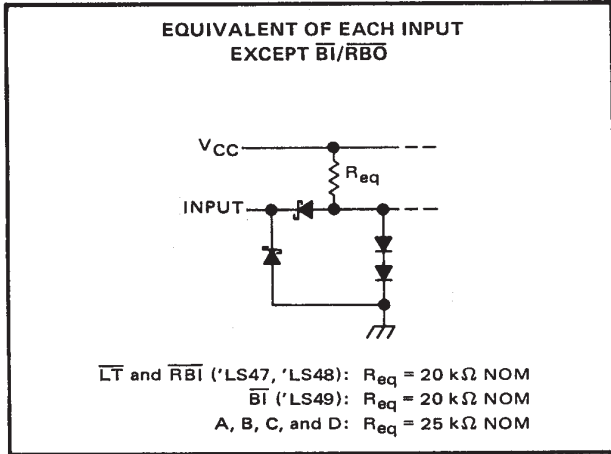

'LS47, 'LS48, 'LS49

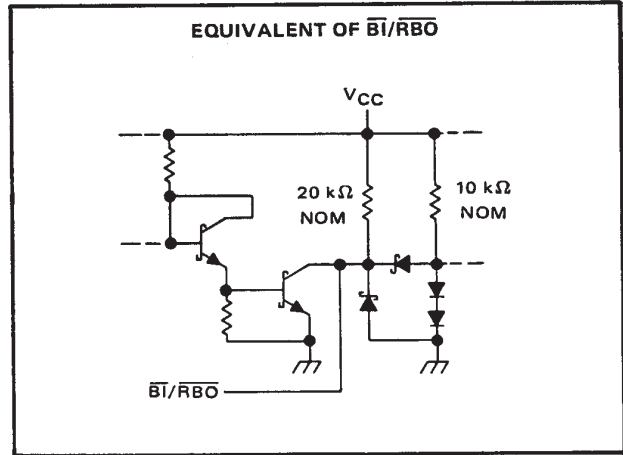

'LS47

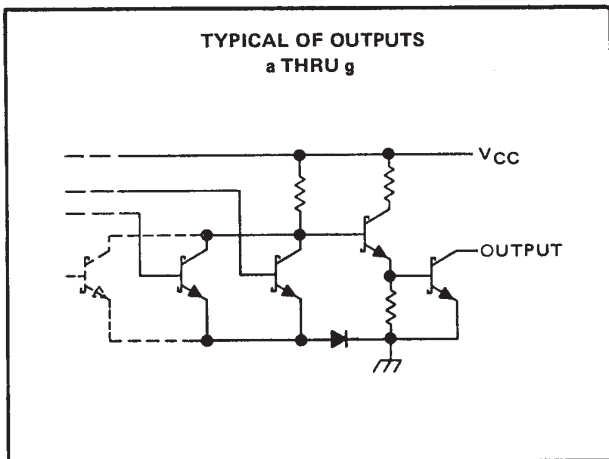

'LS48

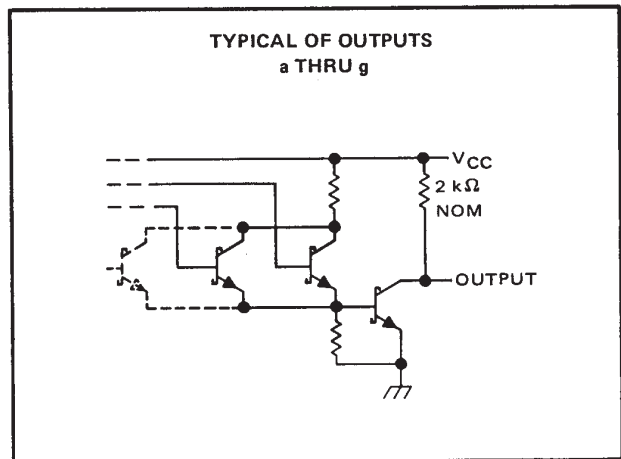

'LS49

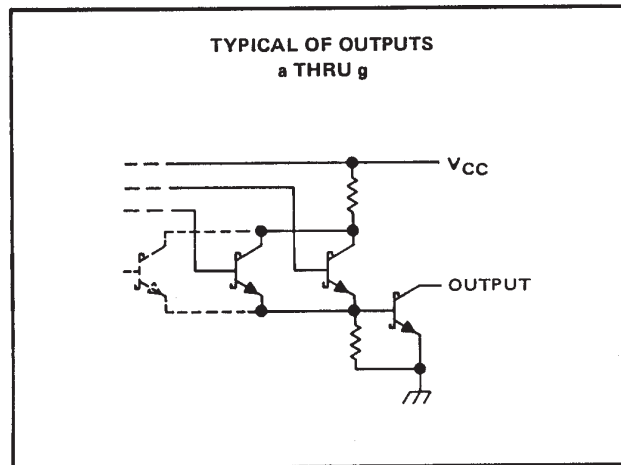

SN5446A, '47A, '48, SN54LS47, 'LS48, 'LS49
 SN7446A, '47A, '48, SN74LS47, 'LS48, 'LS49
 BCD-TO-SEVEN-SEGMENT DECODERS/DRIVERS
 SDLS111 – MARCH 1974 – REVISED MARCH 1988

absolute maximum ratings over operating free-air temperature range (unless otherwise noted)

Supply voltage, V_{CC} (see Note 1)	7 V
Input voltage	5.5 V
Current forced into any output in the off state	1 mA
Operating free-air temperature range: SN5446A, SN5447A	–55°C to 125°C
SN7446A, SN7447A	0°C to 70°C
Storage temperature range	–65°C to 150°C

NOTE 1: Voltage values are with respect to network ground terminal.

recommended operating conditions

	SN5446A			SN5447A			SN7446A			SN7447A			UNIT
	MIN	NOM	MAX	MIN	NOM	MAX	MIN	NOM	MAX	MIN	NOM	MAX	
Supply voltage, V_{CC}	4.5	5	5.5	4.5	5	5.5	4.75	5	5.25	4.75	5	5.25	V
Off-state output voltage, $V_{O(off)}$	a thru g			15			30			15			V
On-state output current, $I_{O(on)}$	a thru g			40			40			40			mA
High-level output current, I_{OH}	$\overline{BI}/\overline{RBO}$			–200			–200			–200			μ A
Low-level output current, I_{OL}	$\overline{BI}/\overline{RBO}$			8			8			8			mA
Operating free-air temperature, T_A	–55			125			0			70			°C

electrical characteristics over recommended operating free-air temperature range (unless otherwise noted)

PARAMETER		TEST CONDITIONS†	MIN	TYP‡	MAX	UNIT	
V_{IH}	High-level input voltage		2			V	
V_{IL}	Low-level input voltage			0.8		V	
V_{IK}	Input clamp voltage	$V_{CC} = \text{MIN}, I_I = -12 \text{ mA}$			–1.5	V	
V_{OH}	High-level output voltage	$\overline{BI}/\overline{RBO}$ $V_{CC} = \text{MIN}, V_{IH} = 2 \text{ V}, V_{IL} = 0.8 \text{ V}, I_{OH} = -200 \mu\text{A}$	2.4	3.7		V	
V_{OL}	Low-level output voltage	$\overline{BI}/\overline{RBO}$ $V_{CC} = \text{MIN}, V_{IH} = 2 \text{ V}, V_{IL} = 0.8 \text{ V}, I_{OL} = 8 \text{ mA}$	0.27	0.4		V	
$I_{O(off)}$	Off-state output current	a thru g $V_{CC} = \text{MAX}, V_{IH} = 2 \text{ V}, V_{IL} = 0.8 \text{ V}, V_{O(off)} = \text{MAX}$			250	μ A	
$V_{O(on)}$	On-state output voltage	a thru g $V_{CC} = \text{MIN}, V_{IH} = 2 \text{ V}, V_{IL} = 0.8 \text{ V}, I_{O(on)} = 40 \text{ mA}$	0.3	0.4		V	
I_I	Input current at maximum input voltage	Any input except $\overline{BI}/\overline{RBO}$ $V_{CC} = \text{MAX}, V_I = 5.5 \text{ V}$			1	mA	
I_{IH}	High-level input current	Any input except $\overline{BI}/\overline{RBO}$ $V_{CC} = \text{MAX}, V_I = 2.4 \text{ V}$			40	μ A	
I_{IL}	Low-level input current	Any input except $\overline{BI}/\overline{RBO}$ $V_{CC} = \text{MAX}, V_I = 0.4 \text{ V}$			–1.6	mA	
		$\overline{BI}/\overline{RBO}$			–4		
I_{OS}	Short-circuit output current	$\overline{BI}/\overline{RBO}$ $V_{CC} = \text{MAX}$			–4	mA	
I_{CC}	Supply current	$V_{CC} = \text{MAX},$ See Note 2			64	85	mA
					64	103	

†For conditions shown as MIN or MAX, use the appropriate value specified under recommended operating conditions.

‡All typical values are at $V_{CC} = 5 \text{ V}, T_A = 25^\circ\text{C}$.

NOTE 2: I_{CC} is measured with all outputs open and all inputs at 4.5 V.

switching characteristics, $V_{CC} = 5 \text{ V}, T_A = 25^\circ\text{C}$

PARAMETER		TEST CONDITIONS	MIN	TYP	MAX	UNIT
t_{off}	Turn-off time from A input	$C_L = 15 \text{ pF}, R_L = 120 \Omega,$ See Note 3			100	ns
t_{on}	Turn-on time from A input				100	
t_{off}	Turn-off time from \overline{RBI} input				100	ns
t_{on}	Turn-on time from \overline{RBI} input				100	

NOTE 3: Load circuits and voltage waveforms are shown in Section 1.



SN5446A, '47A, '48, SN54LS47, 'LS48, 'LS49
 SN7446A, '47A, '48, SN74LS47, 'LS48, 'LS49
 BCD-TO-SEVEN-SEGMENT DECODERS/DRIVERS

SDLS111 – MARCH 1974 – REVISED MARCH 1988

absolute maximum ratings over operating free-air temperature range (unless otherwise noted)

Supply voltage, V_{CC} (see Note 1)	7 V
Input voltage	5.5 V
Operating free-air temperature range: SN5448	-55°C to 125°C
SN7448	0°C to 70°C
Storage temperature range	-65°C to 150°C

NOTE 1: Voltage values are with respect to network ground terminal.

recommended operating conditions

	SN5448			SN7448			UNIT
	MIN	NOM	MAX	MIN	NOM	MAX	
Supply voltage, V_{CC}	4.5	5	5.5	4.75	5	5.25	V
High-level output current, I_{OH}	a thru g		-400			-400	μ A
	$\overline{BI}/\overline{RB\overline{O}}$		-200			-200	
Low-level output current, I_{OL}	a thru g		6.4			6.4	mA
	$\overline{BI}/\overline{RB\overline{O}}$		8			8	
Operating free-air temperature, T_A		-55	125		0	70	°C

electrical characteristics over recommended operating free-air temperature range (unless otherwise noted)

PARAMETER		TEST CONDITIONS†	MIN	TYP‡	MAX	UNIT
V_{IH}	High-level input voltage		2			V
V_{IL}	Low-level input voltage				0.8	V
V_{IK}	Input clamp voltage	$V_{CC} = \text{MIN}, I_I = -12 \text{ mA}$			-1.5	V
V_{OH}	High-level output voltage	a thru g	$V_{CC} = \text{MIN}, V_{IH} = 2 \text{ V},$	2.4	4.2	V
		$\overline{BI}/\overline{RB\overline{O}}$	$V_{IL} = 0.8 \text{ V}, I_{OH} = \text{MAX}$	2.4	3.7	
I_O	Output current	a thru g	$V_{CC} = \text{MIN}, V_O = 0.85 \text{ V},$	-1.3	-2	mA
			Input conditions as for V_{OH}			
V_{OL}	Low-level output voltage		$V_{CC} = \text{MIN}, V_{IH} = 2 \text{ V},$	0.27	0.4	V
			$V_{IL} = 0.8 \text{ V}, I_{OL} = \text{MAX}$			
I_I	Input current at maximum input voltage	Any input except $\overline{BI}/\overline{RB\overline{O}}$	$V_{CC} = \text{MAX}, V_I = 5.5 \text{ V}$		1	mA
I_{IH}	High-level input current	Any input except $\overline{BI}/\overline{RB\overline{O}}$	$V_{CC} = \text{MAX}, V_I = 2.4 \text{ V}$		40	
I_{IL}	Low-level input current	Any input except $\overline{BI}/\overline{RB\overline{O}}$	$V_{CC} = \text{MAX}, V_I = 0.4 \text{ V}$		-1.6	mA
		$\overline{BI}/\overline{RB\overline{O}}$			-4	
I_{OS}	Short-circuit output current	$\overline{BI}/\overline{RB\overline{O}}$	$V_{CC} = \text{MAX}$		-4	mA
I_{CC}	Supply current		$V_{CC} = \text{MAX},$ See Note 2	SN5448 53	76 90	
				SN7448 53	90	

† For conditions shown as MIN or MAX, use the appropriate value specified under recommended operating conditions.

‡ All typical values are at $V_{CC} = 5 \text{ V}, T_A = 25^\circ\text{C}$.

NOTE 2: I_{CC} is measured with all outputs open and all inputs at 4.5 V.

switching characteristics, $V_{CC} = 5 \text{ V}, T_A = 25^\circ\text{C}$

PARAMETER	TEST CONDITIONS	MIN	TYP	MAX	UNIT	
t_{PHL}	$C_L = 15 \text{ pF}, R_L = 1 \text{ k}\Omega$ See Note 3		100		ns	
t_{PLH}			100			
t_{PHL}				100		ns
t_{PLH}				100		

NOTE 3: Load circuits and voltage waveforms are shown in Section 1.



**SN5446A, '47A, '48, SN54LS47, 'LS48, 'LS49
SN7446A, '47A, '48, SN74LS47, 'LS48, 'LS49
BCD-TO-SEVEN-SEGMENT DECODERS/DRIVERS**
SDLS111 – MARCH 1974 – REVISED MARCH 1988

absolute maximum ratings over operating free-air temperature range (unless otherwise noted)

Supply voltage, V_{CC} (see Note 1)	7 V
Input voltage	7 V
Peak output current ($t_w \leq 1$ ms, duty cycle $\leq 10\%$)	200 mA
Current forced into any output in the off state	1 mA
Operating free-air temperature range: SN54LS47	-55°C to 125°C
SN74LS47	0°C to 70°C
Storage temperature range	-65°C to 150°C

NOTE 1: Voltage values are with respect to network ground terminal.

recommended operating conditions

	SN54LS47			SN74LS47			UNIT
	MIN	NOM	MAX	MIN	NOM	MAX	
Supply voltage, V_{CC}	4.5	5	5.5	4.75	5	5.25	V
Off-state output voltage, $V_{O(off)}$	a thru g			15			V
On-state output current, $I_{O(on)}$	a thru g			12			24 mA
High-level output current, I_{OH}	$\overline{BI}/\overline{RBO}$			-50			μA
Low-level output current, I_{OL}	$\overline{BI}/\overline{RBO}$			1.6			3.2 mA
Operating free-air temperature, T_A	-55		125	0		70	$^\circ\text{C}$

electrical characteristics over recommended operating free-air temperature range (unless otherwise noted)

PARAMETER	TEST CONDITIONS†	SN54LS47			SN74LS47			UNIT	
		MIN	TYP‡	MAX	MIN	TYP‡	MAX		
V_{IH} High-level input voltage		2			2			V	
V_{IL} Low-level input voltage				0.7			0.8	V	
V_{IK} Input clamp voltage	$V_{CC} = \text{MIN}, I_I = -18$ mA			-1.5			-1.5	V	
V_{OH} High-level output voltage	$\overline{BI}/\overline{RBO}$ $V_{CC} = \text{MIN}, V_{IH} = 2$ V, $V_{IL} = V_{IL \text{ max}}, I_{OH} = -50$ μA	2.4	4.2		2.4	4.2		V	
V_{OL} Low-level output voltage	$\overline{BI}/\overline{RBO}$ $V_{CC} = \text{MIN}, V_{IH} = 2$ V, $V_{IL} = V_{IL \text{ max}}$			0.25	0.4		0.25	0.4	V
							0.35	0.5	
$I_{O(off)}$ Off-state output current	a thru g $V_{CC} = \text{MAX}, V_{IH} = 2$ V, $V_{IL} = V_{IL \text{ max}}, V_{O(off)} = 15$ V			250			250	μA	
$V_{O(on)}$ On-state output voltage	a thru g $V_{CC} = \text{MIN}, V_{IH} = 2$ V, $V_{IL} = V_{IL \text{ max}}$			0.25	0.4		0.25	0.4	V
							0.35	0.5	
I_I Input current at maximum input voltage	$V_{CC} = \text{MAX}, V_I = 7$ V			0.1			0.1	mA	
I_{IH} High-level input current	$V_{CC} = \text{MAX}, V_I = 2.7$ V			20			20	μA	
I_{IL} Low-level input current	Any input except $\overline{BI}/\overline{RBO}$ $\overline{BI}/\overline{RBO}$ $V_{CC} = \text{MAX}, V_I = 0.4$ V			-0.4			-0.4	mA	
				-1.2			-1.2		
I_{OS} Short-circuit output current	$\overline{BI}/\overline{RBO}$ $V_{CC} = \text{MAX}$	-0.3		-2			-0.3	-2	mA
I_{CC} Supply current	$V_{CC} = \text{MAX},$ See Note 2		7	13		7	13	mA	

†For conditions shown as MIN or MAX, use the appropriate value specified under recommended operating conditions.

‡All typical values are at $V_{CC} = 5$ V, $T_A = 25^\circ\text{C}$.

NOTE 2: I_{CC} is measured with all outputs open and all inputs at 4.5 V.

switching characteristics, $V_{CC} = 5$ V, $T_A = 25^\circ\text{C}$

PARAMETER	TEST CONDITIONS	MIN	TYP	MAX	UNIT
t_{off} Turn-off time from A input	$C_L = 15$ pF, $R_L = 665$ Ω , See Note 3			100	ns
t_{on} Turn-on time from A input				100	
t_{off} Turn-off time from \overline{RBI} input, outputs (a-f) only				100	ns
t_{on} Turn-on time from \overline{RBI} input, outputs (a-f) only				100	

NOTE 3: Load circuits and voltage waveforms are shown in Section 1.



SN5446A, '47A, '48, SN54LS47, 'LS48, 'LS49
SN7446A, '47A, '48, SN74LS47, 'LS48, 'LS49
BCD-TO-SEVEN-SEGMENT DECODERS/DRIVERS

SDLS111 – MARCH 1974 – REVISED MARCH 1988

absolute maximum ratings over operating free-air temperature range (unless otherwise noted)

Supply voltage, V_{CC} (see Note 1)	7 V
Input voltage	7 V
Operating free-air temperature range: SN54LS48	-55°C to 125°C
SN74LS48	0°C to 70°C
Storage temperature range	-65°C to 150°C

NOTE 1: Voltage values are with respect to network ground terminal.

recommended operating conditions

	SN54LS48			SN74LS48			UNIT
	MIN	NOM	MAX	MIN	NOM	MAX	
Supply voltage, V_{CC}	4.5	5	5.5	4.75	5	5.25	V
High-level output current, I_{OH}	a thru g		-100			-100	μ A
	$\overline{BI}/\overline{RBO}$		-50			-50	
Low-level output current, I_{OL}	a thru g		2			6	mA
	$\overline{BI}/\overline{RBO}$		1.6			3.2	
Operating free-air temperature, T_A	-55		125	0		70	°C

electrical characteristics over recommended operating free-air temperature range (unless otherwise noted)

PARAMETER	TEST CONDITIONS†	SN54LS48			SN74LS48			UNIT	
		MIN	TYP‡	MAX	MIN	TYP‡	MAX		
V_{IH} High-level input voltage		2			2			V	
V_{IL} Low-level input voltage				0.7			0.8	V	
V_{IK} Input clamp voltage	$V_{CC} = \text{MIN}, I_I = -18 \text{ mA}$			-1.5			-1.5	V	
V_{OH} High-level output voltage	a thru g and $\overline{BI}/\overline{RBO}$ $V_{CC} = \text{MIN}, V_{IH} = 2 \text{ V}, V_{IL} = V_{IL \text{ max}}, I_{OH} = \text{MAX}$	2.4	4.2		2.4	4.2		V	
I_O Output current	a thru g $V_{CC} = \text{MIN}, V_O = 0.85 \text{ V},$ Input conditions as for V_{OH}	-1.3	-2		-1.3	-2		mA	
V_{OL} Low-level output voltage	a thru g $V_{CC} = \text{MIN}, V_{IH} = 2 \text{ V}, V_{IL} = V_{IL \text{ max}}$	$I_{OL} = 2 \text{ mA}$	0.25	0.4	0.25	0.4		V	
		$I_{OL} = 6 \text{ mA}$			0.35	0.5		V	
	$\overline{BI}/\overline{RBO}$ $V_{CC} = \text{MIN}, V_{IH} = 2 \text{ V}, V_{IL} = V_{IL \text{ max}}$	$I_{OL} = 1.6 \text{ mA}$	0.25	0.4	0.25	0.4		V	
		$I_{OL} = 3.2 \text{ mA}$			0.35	0.5		V	
I_I Input current at maximum input voltage	Any input except $\overline{BI}/\overline{RBO}$ $V_{CC} = \text{MAX}, V_I = 7 \text{ V}$			0.1			0.1	mA	
I_{IH} High-level input current	Any input except $\overline{BI}/\overline{RBO}$ $V_{CC} = \text{MAX}, V_I = 2.7 \text{ V}$			20			20	μ A	
I_{IL} Low-level input current	Any input except $\overline{BI}/\overline{RBO}$ $V_{CC} = \text{MAX}, V_I = 0.4 \text{ V}$			-0.4			-0.4	mA	
	$\overline{BI}/\overline{RBO}$			-1.2			-1.2	mA	
I_{OS} Short-circuit output current	$\overline{BI}/\overline{RBO}$ $V_{CC} = \text{MAX}$	-0.3		-2	-0.3		-2	mA	
I_{CC} Supply current	$V_{CC} = \text{MAX},$ See Note 2			25	38		25	38	mA

†For conditions shown as MIN or MAX, use the appropriate value specified under recommended operating conditions.

‡All typical values are at $V_{CC} = 5 \text{ V}, T_A = 25^\circ\text{C}$.

NOTE 2: I_{CC} is measured with all outputs open and all inputs at 4.5 V.

switching characteristics, $V_{CC} = 5 \text{ V}, T_A = 25^\circ\text{C}$

PARAMETER	TEST CONDITIONS	MIN	TYP	MAX	UNIT
t_{PHL} Propagation delay time, high-to-low-level output from A input	$C_L = 15 \text{ pF}, R_L = 4 \text{ k}\Omega,$			100	ns
t_{PLH} Propagation delay time, low-to-high-level output from A input	See Note 3			100	
t_{PHL} Propagation delay time, high-to-low-level output (a-f only) from \overline{RBI} input	$C_L = 15 \text{ pF}, R_L = 6 \text{ k}\Omega,$			100	ns
t_{PLH} Propagation delay time, low-to-high-level output (a-f only) from \overline{RBI} input	See Note 3			100	

NOTE 3: Load circuits and voltage waveforms are shown in Section 1.



POST OFFICE BOX 655303 • DALLAS, TEXAS 75265

SN5446A, '47A, '48, SN54LS47, 'LS48, 'LS49
 SN7446A, '47A, '48, SN74LS47, 'LS48, 'LS49
BCD-TO-SEVEN-SEGMENT DECODERS/DRIVERS
 SDLS111 – MARCH 1974 – REVISED MARCH 1988

absolute maximum ratings over operating free-air temperature range (unless otherwise noted)

Supply voltage, V_{CC} (see Note 1)	7 V
Input voltage	7 V
Current forced into any output in the off state	1 mA
Operating free-air temperature range: SN54LS49	-55°C to 125°C
SN74LS49	0°C to 70°C
Storage temperature range	-65°C to 150°C

NOTE 1: Voltage values are with respect to network ground terminal.

recommended operating conditions

	SN54LS49			SN74LS49			UNIT
	MIN	NOM	MAX	MIN	NOM	MAX	
Supply voltage, V_{CC}	4.5	5	5.5	4.75	5	5.25	V
High-level output voltage, V_{OH}			5.5			5.5	V
Low-level output current, I_{OL}			4			8	mA
Operating free-air temperature, T_A	-55		125	0		70	°C

electrical characteristics over recommended operating free-air temperature range (unless otherwise noted)

PARAMETER	TEST CONDITIONS†	SN54LS49			SN74LS49			UNIT
		MIN	TYP‡	MAX	MIN	TYP‡	MAX	
V_{IH} High-level input voltage		2			2			V
V_{IL} Low-level input voltage				0.7			0.8	V
V_{IK} Input clamp voltage	$V_{CC} = \text{MIN}, I_I = -18 \text{ mA}$			-1.5			-1.5	V
I_{OH} High-level output current	$V_{CC} = \text{MIN}, V_{IH} = 2 \text{ V}, V_{IL} = V_{IL \text{ max}}, V_{OH} = 5.5 \text{ V}$			250			250	µA
V_{OL} Low-level output voltage	$V_{CC} = \text{MIN}, V_{IH} = 2 \text{ V}, V_{IL} = V_{IL \text{ max}}, I_{OL} = 4 \text{ mA}$		0.25	0.4		0.25	0.4	V
	$I_{OL} = 8 \text{ mA}$					0.35	0.5	
I_I Input current at maximum input voltage	$V_{CC} = \text{MAX}, V_I = 7 \text{ V}$			0.1			0.1	mA
I_{IH} High-level input current	$V_{CC} = \text{MAX}, V_I = 2.7 \text{ V}$			20			20	µA
I_{IL} Low-level input current	$V_{CC} = \text{MAX}, V_I = 0.4 \text{ V}$			-0.4			-0.4	mA
I_{CC} Supply current	$V_{CC} = \text{MAX}, \text{ See Note 2}$		8	15		8	15	mA

†For conditions shown as MIN or MAX, use the appropriate value specified under recommended operating conditions.

‡All typical values are at $V_{CC} = 5 \text{ V}, T_A = 25^\circ\text{C}$.

NOTE 2: I_{CC} is measured with all outputs open and all inputs at 4.5 V.

switching characteristics, $V_{CC} = 5 \text{ V}, T_A = 25^\circ\text{C}$

PARAMETER	TEST CONDITIONS	MIN	TYP	MAX	UNIT
t_{PHL} Propagation delay time, high-to-low-level output from A input	$C_L = 15 \text{ pF}, R_L = 4 \text{ k}\Omega$			100	ns
t_{PLH} Propagation delay time, low-to-high-level output from A input	See Note 3			100	
t_{PHL} Propagation delay time, high-to-low-level output (a-f only) from $\overline{\text{RBI}}$ input	$C_L = 15 \text{ pF}, R_L = 6 \text{ k}\Omega$			100	ns
t_{PLH} Propagation delay time, low-to-high-level output (a-f only) from $\overline{\text{RBI}}$ input	See Note 3			100	

NOTE 3: Load circuits and voltage waveforms are shown in Section 1.



IMPORTANT NOTICE

Texas Instruments and its subsidiaries (TI) reserve the right to make changes to their products or to discontinue any product or service without notice, and advise customers to obtain the latest version of relevant information to verify, before placing orders, that information being relied on is current and complete. All products are sold subject to the terms and conditions of sale supplied at the time of order acknowledgement, including those pertaining to warranty, patent infringement, and limitation of liability.

TI warrants performance of its semiconductor products to the specifications applicable at the time of sale in accordance with TI's standard warranty. Testing and other quality control techniques are utilized to the extent TI deems necessary to support this warranty. Specific testing of all parameters of each device is not necessarily performed, except those mandated by government requirements.

CERTAIN APPLICATIONS USING SEMICONDUCTOR PRODUCTS MAY INVOLVE POTENTIAL RISKS OF DEATH, PERSONAL INJURY, OR SEVERE PROPERTY OR ENVIRONMENTAL DAMAGE ("CRITICAL APPLICATIONS"). TI SEMICONDUCTOR PRODUCTS ARE NOT DESIGNED, AUTHORIZED, OR WARRANTED TO BE SUITABLE FOR USE IN LIFE-SUPPORT DEVICES OR SYSTEMS OR OTHER CRITICAL APPLICATIONS. INCLUSION OF TI PRODUCTS IN SUCH APPLICATIONS IS UNDERSTOOD TO BE FULLY AT THE CUSTOMER'S RISK.

In order to minimize risks associated with the customer's applications, adequate design and operating safeguards must be provided by the customer to minimize inherent or procedural hazards.

TI assumes no liability for applications assistance or customer product design. TI does not warrant or represent that any license, either express or implied, is granted under any patent right, copyright, mask work right, or other intellectual property right of TI covering or relating to any combination, machine, or process in which such semiconductor products or services might be or are used. TI's publication of information regarding any third party's products or services does not constitute TI's approval, warranty or endorsement thereof.