

27-Line SCSI Source/Sink Regulator

FEATURES

- Complies with SCSI, SCSI-2, SCSI-3 SPI and Ultra SCSI (Fast-20)
- 2.85V Regulated Output Voltage With 1.4% Tolerance
- Provides Current for up to 27 Lines of Active Termination for SCSI Buses
- -750mA Sourcing Current for Termination
- +300mA Sinking Current for Active Negation Drivers
- 0.9V Dropout Voltage Regulator at 750mA and 2.75V Output
- 100 μ A Supply Current in Disconnect Mode
- Current Limit and Thermal Shutdown Protection
- Low Thermal Resistance Surface Mount Packages

DESCRIPTION

The UC560 provides current for up to 27 lines of active termination for a SCSI (Small Computers Systems Interface) parallel bus. The SCSI standard requires active termination at both ends of the cable. The UC560 is based on the UC5603 and UC5613 SCSI Active Terminators. It uses the voltage regulator and internal logic circuits of those parts, but has no termination circuits. The UC560 provides greater source current drive capability compared to the UC5603 and UC5613.

The UC560 sink current maintains regulation with all active-negation drivers negated. It provides a disconnect feature which disables the regulator to greatly reduce standby power. Internal circuit trimming is utilized for a 1.4% tolerance output voltage. Other features include thermal shutdown and current limit for short circuit conditions.

The UC560 is available in low thermal resistance versions of the industry standard 8-pin power SOIC, 5-pin TO-220 and 5-pin TO-263.

BLOCK DIAGRAM

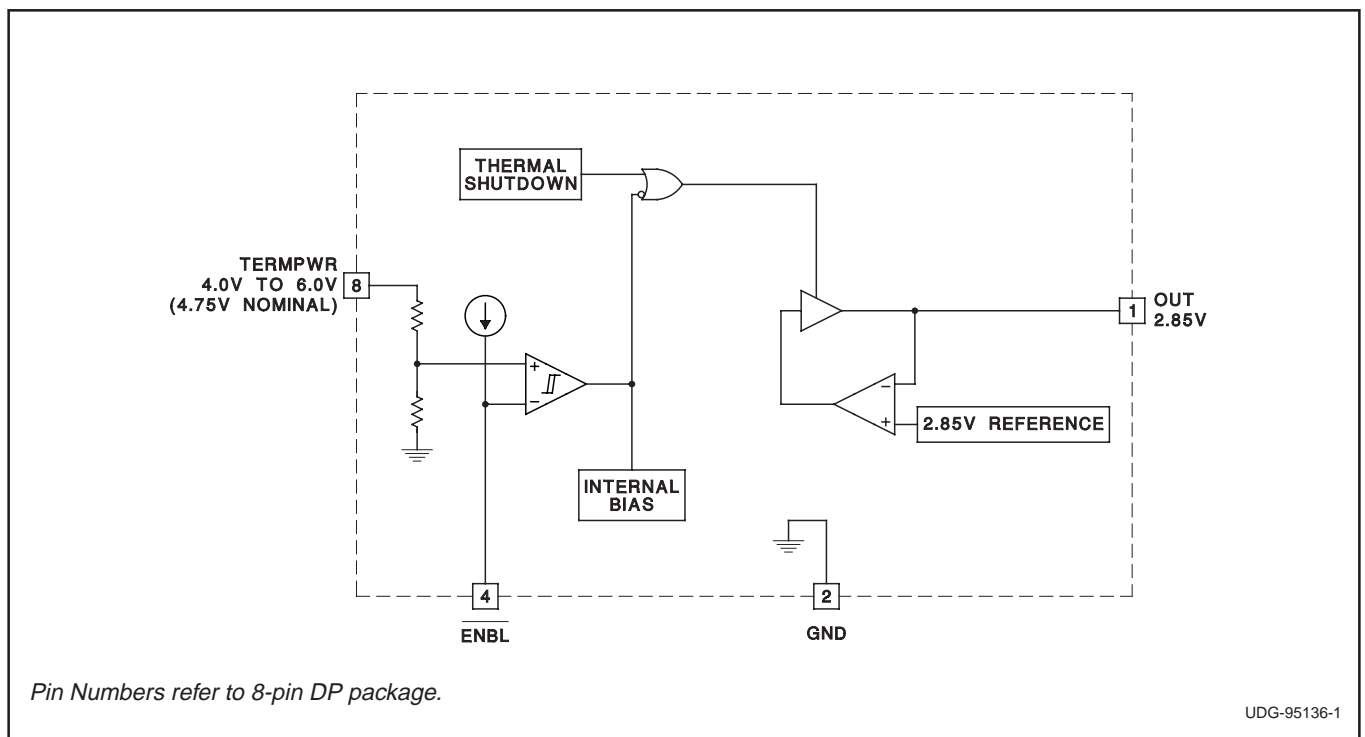

ABSOLUTE MAXIMUM RATINGS

| | |
|---------------------------------------|-------------------------|
| TERMPWR Voltage | 7V |
| ENBL Voltage | -0.3V to TERMPWR + 0.3V |
| Regulator Output Current | 1.4A |
| Power Dissipation | 2.5W |
| Storage Temperature | -65°C to +150°C |
| Junction Temperature | -55°C to +150°C |
| Lead Temperature (Soldering, 10 sec.) | +300°C |

Currents are positive into, negative out of the specified terminal. Consult Packaging Section of Databook for thermal limitations and considerations of packages.

RECOMMENDED OPERATING CONDITIONS

| | |
|-----------------|---------------|
| TERMPWR Voltage | 4.0V to 6.0V |
| ENBL Voltage | 0V to TERMPWR |

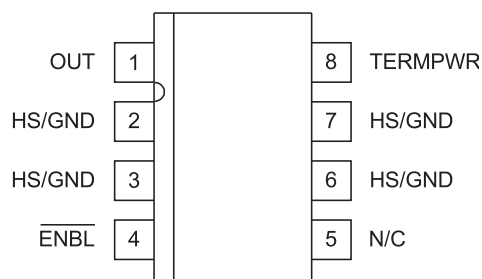
CONNECTION DIAGRAMS**SOIC-8 (Top View)
DP Package**

Note: Pins 2,3,6, and 7 are heat sinking pins. Pin 2 is the connect point for electrical ground.

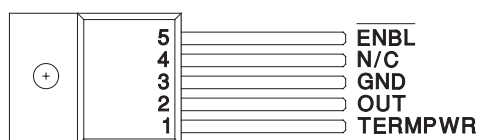
**5-Pin TO-220 (Top View)
T Package**

Note: TAB is ground.

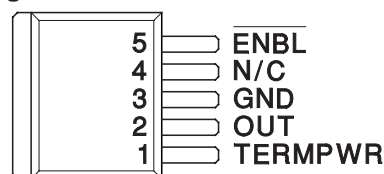
**5-Pin TO-263 (Top View)
TD Package**

Note: TAB is ground.

ELECTRICAL CHARACTERISTICS Unless otherwise specified, $T_A = 0^\circ\text{C}$ to 70°C , $\text{TERMPWR} = 4.75\text{V}$, $\overline{\text{ENBL}} = 0\text{V}$, $C_{\text{OUT}} = 4.7\mu\text{F}$, $C_{\text{TERMPWR}} = 4.7\mu\text{F}$, $T_A = T_J$.

| PARAMETER | TEST CONDITIONS | MIN | TYP | MAX | UNITS |
|---|---|-------|------|------|------------------|
| Supply Current Section | | | | | |
| TERMPWR Supply Current | No Load | | 16 | 22 | mA |
| | $I_{\text{OUT}} = -700\text{mA}$ | | 710 | 750 | mA |
| Power Down Mode | $\overline{\text{ENBL}} = 2.0\text{V}$ | | 100 | 140 | μA |
| Regulator Section | | | | | |
| Regulator Output Voltage | 25°C , No Load | 2.81 | 2.85 | 2.89 | V |
| Load Regulation | $I_{\text{OUT}} = 300\text{mA}$ to -750mA (Note 2) | | 25 | 30 | mV |
| Line Regulation | $\text{TERMPWR} = 4.0\text{V}$ to 6.0V , No Load (Note 2) | | 10 | 20 | mV |
| Dropout Voltage | $I_{\text{OUT}} = -750\text{mA}$, $V_{\text{OUT}} = 2.75\text{V}$ | | 0.9 | 1.2 | V |
| Short Circuit Current | $V_{\text{OUT}} = 0\text{V}$ | -0.85 | -1.3 | | A |
| Sinking Current | $V_{\text{OUT}} = 3.5\text{V}$ | | 500 | 600 | mA |
| | $\overline{\text{ENBL}} = 2.0\text{V}$, $V_{\text{OUT}} = 3.0\text{V}$ | | 1 | 2 | mA |
| Thermal Shutdown | (Note 1) | | 170 | | $^\circ\text{C}$ |
| Thermal Shutdown Hysteresis | (Note 1) | | 10 | | $^\circ\text{C}$ |
| Shutdown Section | | | | | |
| ENBL Threshold | | 1.1 | 1.4 | 1.7 | V |
| Threshold Hysteresis | | | 100 | | mV |
| $\overline{\text{ENBL}}$ Output Current | | | -10 | -15 | μA |

Note 1: Guaranteed by design. Not 100% tested in production.

Note 2: Tested at a constant junction temperature by low duty cycle pulse testing.

PIN DESCRIPTIONS

ENBL: Enable Bar pin. The $\overline{\text{ENBL}}$ function is active low, and the pin will source $10\mu\text{A}$ typically when at ground and TERMPWR is between 4V and 6V . The part will go into disable mode if $\overline{\text{ENBL}}$ is above 1.4V typical, and will turn back on when $\overline{\text{ENBL}}$ drops below 1.3V typical. The part also greatly reduces TERMPWR current when disabled ($100\mu\text{A}$ typical).

GND: Ground pin.

OUT: 2.85V regulated output voltage pin. The part is internally current limited for both sinking and sourcing cur-

rent to prevent damage. When the part is in disabled mode ($\overline{\text{ENBL}} \geq 1.4\text{V}$ typical), the output goes to 0V with no external supply source on OUT . The part will sink current, though, if there is an external supply voltage applied to OUT when in disabled mode. For best performance, a $4.7\mu\text{F}$ low ESR capacitor is recommended.

TERMPWR: Supply voltage pin. The pin should be decoupled with at least a $2.2\mu\text{F}$ low ESR output capacitor. For best performance, a $4.7\mu\text{F}$ low ESR capacitor is recommended. Lead lengths should be kept at a minimum.

APPLICATIONS INFORMATION

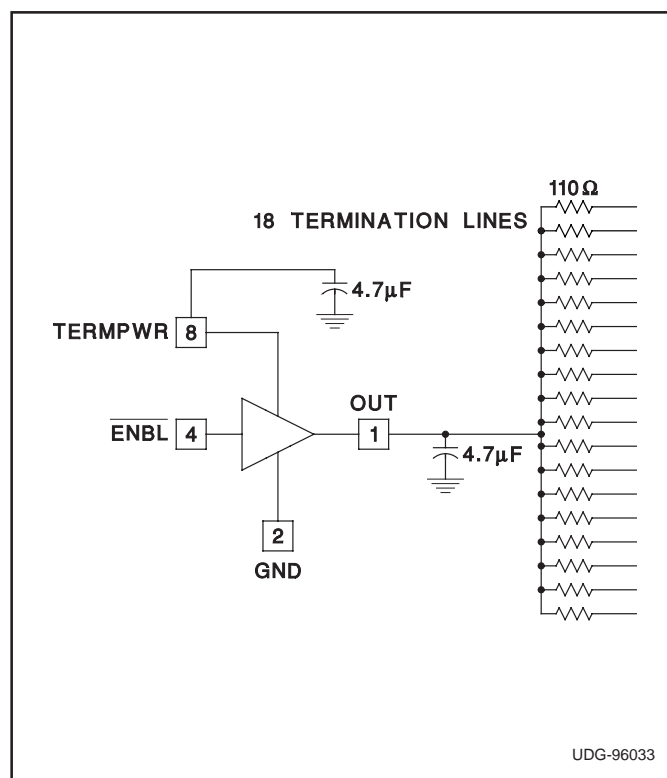

Figure 1. Typical SCSI Bus Configuration Utilizing UC560 Device

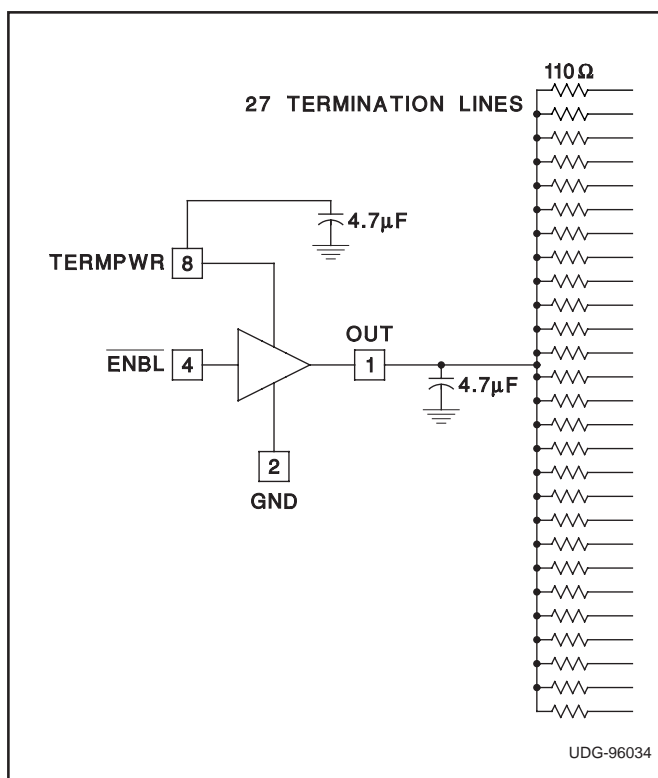

Figure 2. Typical Wide SCSI Bus Configuration Utilizing UC560 Device

TYPICAL CHARACTERISTICS

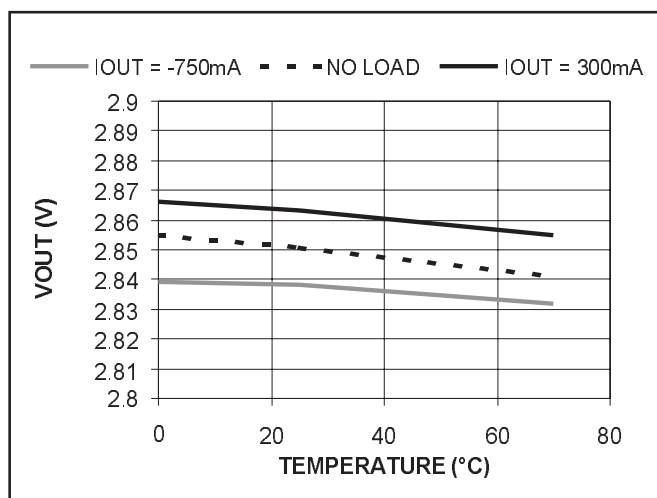

Figure 3. V_{OUT} vs Temperature

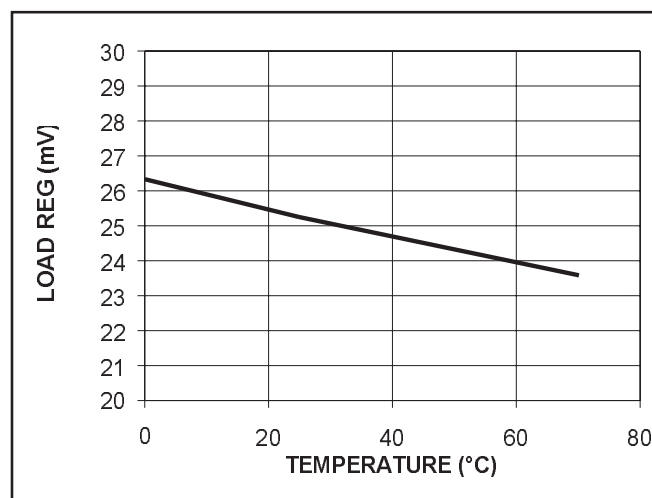

Figure 5. Load Regulation vs. Temperature (I_{OUT} = 300mA to -750mA)

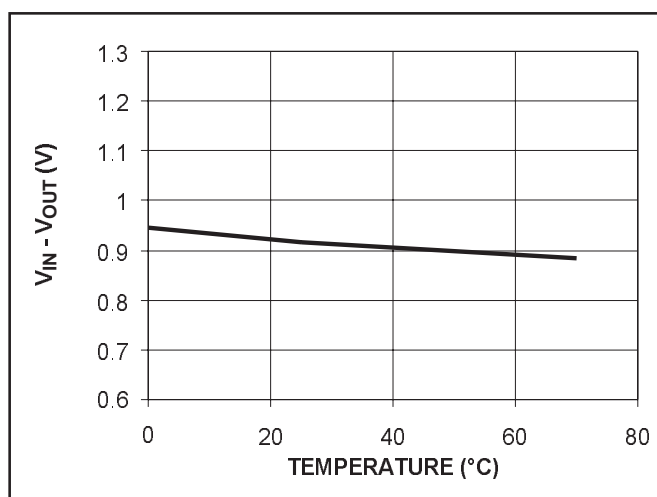

Figure 4. Dropout Voltage vs. Temperature (I_{OUT} = -750mA, V_{OUT} = 2.75V)

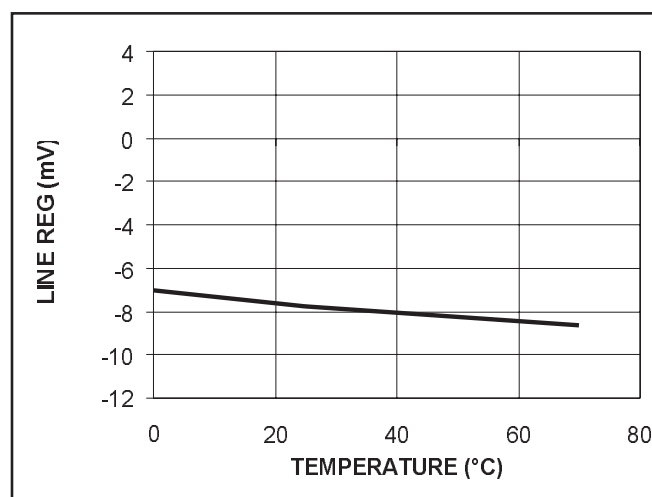

Figure 6. Line Regulation vs Temperature (TERMPWR = 4.0V to 6.0V)

IMPORTANT NOTICE

Texas Instruments and its subsidiaries (TI) reserve the right to make changes to their products or to discontinue any product or service without notice, and advise customers to obtain the latest version of relevant information to verify, before placing orders, that information being relied on is current and complete. All products are sold subject to the terms and conditions of sale supplied at the time of order acknowledgement, including those pertaining to warranty, patent infringement, and limitation of liability.

TI warrants performance of its semiconductor products to the specifications applicable at the time of sale in accordance with TI's standard warranty. Testing and other quality control techniques are utilized to the extent TI deems necessary to support this warranty. Specific testing of all parameters of each device is not necessarily performed, except those mandated by government requirements.

CERTAIN APPLICATIONS USING SEMICONDUCTOR PRODUCTS MAY INVOLVE POTENTIAL RISKS OF DEATH, PERSONAL INJURY, OR SEVERE PROPERTY OR ENVIRONMENTAL DAMAGE ("CRITICAL APPLICATIONS"). TI SEMICONDUCTOR PRODUCTS ARE NOT DESIGNED, AUTHORIZED, OR WARRANTED TO BE SUITABLE FOR USE IN LIFE-SUPPORT DEVICES OR SYSTEMS OR OTHER CRITICAL APPLICATIONS. INCLUSION OF TI PRODUCTS IN SUCH APPLICATIONS IS UNDERSTOOD TO BE FULLY AT THE CUSTOMER'S RISK.

In order to minimize risks associated with the customer's applications, adequate design and operating safeguards must be provided by the customer to minimize inherent or procedural hazards.

TI assumes no liability for applications assistance or customer product design. TI does not warrant or represent that any license, either express or implied, is granted under any patent right, copyright, mask work right, or other intellectual property right of TI covering or relating to any combination, machine, or process in which such semiconductor products or services might be or are used. TI's publication of information regarding any third party's products or services does not constitute TI's approval, warranty or endorsement thereof.