

- LVD-Only Active Termination
- 2.7 V to 5.25 V Operation
- Differential Failsafe Bias
- Built-In SPI-3 Mode Change Filter/Delay
- Standards Supported: SPI-3, Ultra2 (Fast 40), Ultra3/Ultra160 (Fast 80)

description

The UCC5680 is an LVD-only SCSI terminator that integrates the mode change delay function required by the SPI-3 specification. The device senses what types of SCSI drivers are present on the bus via the voltage on the DIFFSENS SCSI control line. Single-ended (SE) and high-voltage differential (HVD) SCSI drivers (EIA485) are not supported. If the chip detects the presence of an SE or HVD SCSI driver, it disconnects itself by switching all terminating resistors off the bus and enters a high-impedance state. The terminator can also be commanded to disconnect the terminating resistors by the DISCNCT input. Impedance is trimmed for accuracy and maximum effectiveness. Bus lines are biased to a failsafe state to ensure signal integrity.

The UCC5680 is offered in both 24-pin and 28-pin TSSOP (PW) packages for a temperature range of 0°C to 70°C.

functional block diagram

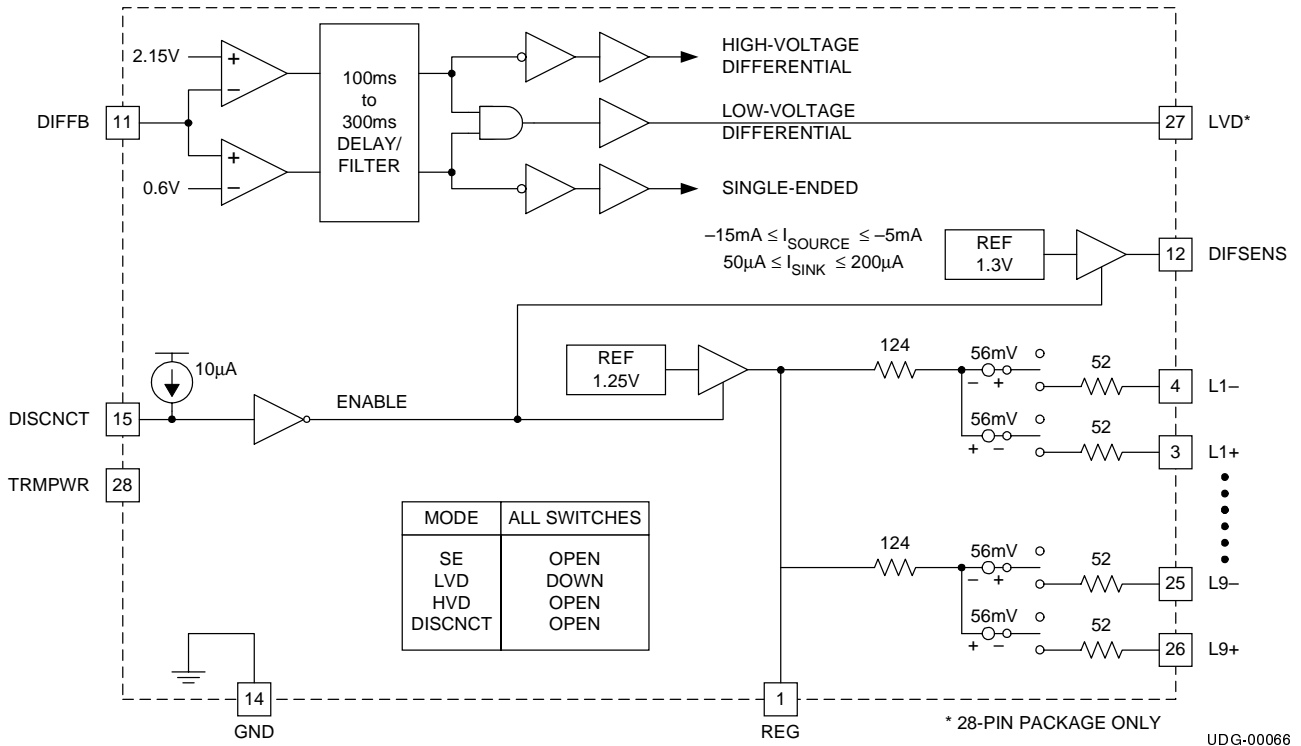

PRODUCT PREVIEW



Please be aware that an important notice concerning availability, standard warranty, and use in critical applications of Texas Instruments semiconductor products and disclaimers thereto appears at the end of this data sheet.

PRODUCT PREVIEW information concerns products in the formative or design phase of development. Characteristic data and other specifications are design goals. Texas Instruments reserves the right to change or discontinue these products without notice.



UCC5680
9-LINE LVD ONLY SCSI TERMINATOR
WITH INTEGRATED SPI-3 DELAYS

SLUS313B - APRIL 1999 - REVISED MARCH 2000

TSSOP PACKAGE (TOP VIEW)

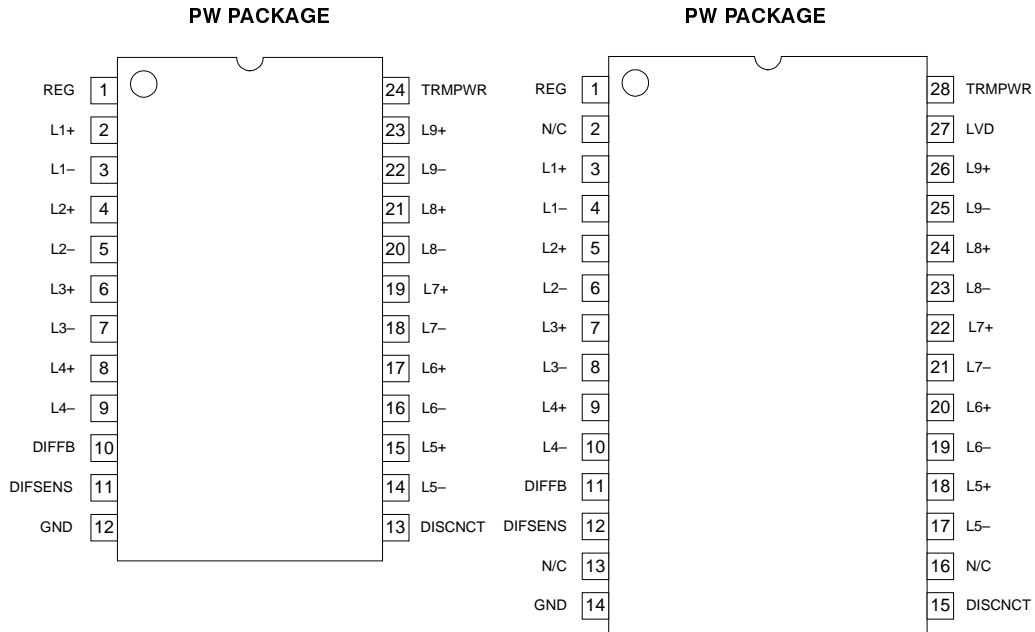

absolute maximum ratings over operating free-air temperature (unless otherwise noted)^{†‡}

TERMPWR Voltage	6 V
Signal Line Voltage	0 V to 5 V
Package Dissipation	0.5 W
Storage Temperature	-65°C to 150°C
Junction Temperature	-55°C to 150°C
Lead Temperature (Soldering, 10 sec.)	300°C

recommended operating conditions^{†‡}

TERMPWR Voltage	2.7V to 5.25V
Operating Temperature Range	0°C to +70°C

[†] Stresses beyond those listed under "absolute maximum ratings" may cause permanent damage to the device. These are stress ratings only, and functional operation of the device at these or any other conditions beyond those indicated under "recommended operating conditions" is not implied. Exposure to absolute-maximum-rated conditions for extended periods may affect device reliability.

[‡] Currents are positive into and negative out of the specified terminal. Consult the Packaging Section of the databook for thermal limitations and considerations of the package.

PRODUCT PREVIEW



UCC5680
9-LINE LVD ONLY SCSI TERMINATOR
WITH INTEGRATED SPI-3 DELAYS
SLUS313B - APRIL 1999 - REVISED MARCH 2000

**electrical characteristics over recommended operating free-air temperature range,
 $T_A = T_J = 0^\circ\text{C}$ to 70°C , TRMPWR = 2.7V to 5.25V**

PARAMETER	TEST CONDITIONS	MIN	TYP	MAX	UNIT
TRMPWR Supply Current Section					
TRMPWR Supply Current	LVD Mode (No Load)			35	mA
	Disabled Mode			500	μA
Regulator Section					
Regulator Output Voltage	$0.5 \leq V_{CM} \leq 2.0$, See Note 1	1.15	1.25	1.35	V
Regulator Short-Circuit Source Current	$V_{REG} = 0\text{V}$		-100	-80	mA
Regulator Short-Circuit Sink Current	$V_{REG} = 3.0\text{V}$	80	100		mA
DIFSENS Output Section					
Output Voltage	$-5\text{mA} \leq I_{DIFSENS} \leq 50\mu\text{A}$	1.2	1.3	1.4	V
Short-Circuit Source Current	$V_{DIFSENS} = 0\text{V}$	-15		-5	mA
Short-Circuit Sink Current	$V_{DIFSENS} = 2.75\text{V}$	50		200	μA
Differential Termination Section (Applies to each line pair, 1-9, in LVD mode)					
Differential Impedance		100	105	110	Ω
Common-Mode Impedance	L+ and L- shorted together, See Note 2	110	150	165	Ω
Differential Bias Voltage		100		125	mV
Common-Mode Bias Voltage	L+ and L- shorted together	1.15	1.25	1.35	V
Disconnected Termination Section (Applies to each line pair, 1-9, in DISCNCT, SE or HVD mode)					
Output Leakage				400	nA
Output Capacitance	Single-ended measurement to ground, See Note 3			3	pF
DISCNCT and DIFFB Input Section					
DISCNCT Threshold		0.8		2.0	V
DISCNCT Input Current	$V_{DISCNCT} = 0\text{V}$ and 2.0V	-30	-10		μA
DIFFB SE to LVD Threshold		0.5		0.7	V
DIFFB LVD to HVD Threshold		1.9		2.4	V
DIFFB Input Current	$0\text{V} \leq V_{DIFFB} \leq 2.75$	-10		10	μA
Low Voltage Differential (LVD) Status Bit Section (See Note 4)					
I_{SOURCE}	$V_{LOAD} = 2.4\text{V}$		-6	-4	mA
I_{SINK}	$V_{LOAD} = 0.4\text{V}$	2	5		mA
Time Delay/Filter Section					
Mode Change Delay	A new mode change can start any time after a previous mode change has been detected	100	190	300	ms
Thermal Shutdown Section					
Thermal Shutdown Threshold	For increasing temperature	140	155	170	$^\circ\text{C}$
Thermal Shutdown Hysteresis			10		$^\circ\text{C}$

NOTES: 1. V_{CM} is applied to all L+ and L- lines simultaneously.

$$2. Z_{CM} = \frac{(2.0\text{V} - 0.5\text{V})}{[I_{VCM(max)} - I_{VCM(min)}]} @ V_{CM(max)} = 2.0, V_{CM(min)} = 0.5$$

3. Ensured by design, not production tested.

4. This applies to the 28-pin package only.

PRODUCT PREVIEW



UCC5680

9-LINE LVD ONLY SCSI TERMINATOR WITH INTEGRATED SPI-3 DELAYS

SLUS313B - APRIL 1999 - REVISED MARCH 2000

pin descriptions

DIFFB: DIFFSENS input pin. Connect through a 20-k Ω resistor to DIFSENS and through a 0.1- μ F capacitor to ground. Input to comparators that detect what types of drivers are connected to the SCSI bus.

DIFSENS: SCSI bus DIFSENS line driver.

DISCNCT: Disconnect pin. Shuts down the terminator (switches terminating resistors off the bus) when open or active (high). The disconnect pin low enables the terminator.

GND: Power supply return.

LINE n -: Line termination pins. Negative line in differential pair.

LINE n +: Line termination pins. Positive line in differential pair.

LVD: (28-pin package only) Indicates that the bus is in LVD mode.

REG: Regulator bypass pin. Bypass near the terminator with a 4.7- μ F and a high-frequency, low-ESR 0.01- μ F capacitor to ground.

TRMPWR: V_{IN} 2.75 V to 5.25 V supply. Bypass near the terminator with a 4.7- μ F and a high-frequency, low-ESR 0.01- μ F capacitor to ground.

APPLICATION INFORMATION

All SCSI buses require a termination network at each end to function properly. Specific termination requirements differ, depending on which types of SCSI driver devices are present on the bus. The UCC5680 is a low-voltage differential (LVD)-only device. It senses which types of drivers are present on the bus. If it detects the presence of a single-ended (SE) or high-voltage differential (HVD) driver, the UCC5680 will place itself in a high-impedance input state, effectively disconnecting the chip from the bus.

The UCC5680 senses what kinds of drivers are present on the bus by the voltage on SCSI bus control line DIFFSENS, which is monitored by the DIFFB input pin. DIFSENS output pin on the 5680 will attempt to drive DIFFSENS control line to 1.3V. If only LVD devices are present, the DIFFSENS line will be successfully driven to that voltage. If HVD drivers are present, they will pull the DIFFSENS line high. If any single-ended drivers are present, they will pull the DIFSENS line to ground (even if HVD drivers are also present on the bus). If the voltage on the DIFFB is below 0.5V or above 2.4V, the UCC5680 will enter the high-impedance SE/HVD state. If it is between 0.7 and 1.9V, the UCC5680 will enter the LVD mode. These thresholds accommodate differences in ground potential that can occur between the ends of long bus lines.

Three UCC5680 ICs are required at each end of the SCSI bus to terminate 27 lines (18 data, 9 control). Every UCC5680 contains a DIFSENS driver, but only one should be used to drive the line at each end. The DIFSENS pin on the other devices should be left unconnected.

On power up (the voltage on the TRMPWR pin rising above 2.7 V), the UCC5680 assumes the SE/HVD mode. If the voltage on the DIFFB input indicates LVD mode, the chip waits 100 to 300 ms before changing the mode of the bus. If the voltage at the DIFFB input later crosses one of the thresholds above, the UCC5680 again waits 100 ms to 300 ms before changing the mode of the bus. The magnitude of the delay is the same when changing in or out of either bus mode. A new mode change can start anytime after a previous mode change has been detected.

The DIFFB inputs on all three chips at each end of the bus should be connected together. Properly filtered, noise on DIFFB will not cause a false mode change—there should be a shared 50 Hz noise filter implemented on DIFFB at each end of the bus as close as possible to the DIFFB pins. This is implemented with a 20-k Ω resistor between the DIFFB and DIFSENS pins, and a 0.1- μ F capacitor from DIFFB to ground. See the *Typical Application* diagram at the end of this datasheet.



POST OFFICE BOX 655303 • DALLAS, TEXAS 75265

APPLICATION INFORMATION (continued)

In LVD mode, the regulated voltage is switched to 1.25 V, and a resistor network is presented to each line pair that provides common-mode impedance of 150 Ω and differential impedance of 105 Ω. The lines in each differential pair are biased so that when not driven, Line(n)+ and Line(n)- are driven 56 mV below and above the common-mode bias voltage (1.25 V) respectively.

In SE/HVD mode, all the terminating resistors are switched off the bus. The 1.25 V and 1.3 V (DIFSENS) regulators are left on.

When the disconnect input (DISCNCT) is active (high), the terminating resistors are switched off the bus and both voltage regulators are turned off to save power. The mode change filter/delay function is still active and the LVD pin (in the 28-pin package) continues to indicate the correct bus mode.

The UCC5680 operates in spec down to a TRMPWR voltage of 2.7 V. This accommodates 3.3 V system with allowance for supply tolerance (±10%), a unidirectional fusing device, and cable drop. The UCC3916 is recommended in place of a fuse and diode implementation, as its lower voltage drop provides additional voltage margin for the system.

Layout is important in all SCSI implementations and critical in SPI-3 systems, which have stringent requirements on both the absolute value of capacitance on differential signal lines and the balancing of capacitance between paired lines and from pair to pair.

Feedthroughs, through-hole connections, and etch lengths need to be carefully balanced. Standard multilayer power and ground plane spacing adds about 1 pF to each plane. Each feed-through will add 2.5 pF to 3.5 pF. Enlarging the clearance holes on both power and ground planes will reduce capacitance. Opening up the power and ground planes under a through-hole connector will reduce added capacitance in those applications. Capacitance will also be affected by components in close proximity on both sides of the board.

maximum capacitance

SCSI Class	Trace to GND: REQ, ACK, DATA, Parity, P_CRCA	Trace to Trace: REQ, ACK, DATA, Parity, P_CRCA	Trace to GND: Other signals	Trace to Trace: Other Signals
Ultra1	25 pF	N/A	25 pF	N/A
Ultra2	20 pF	10 pF	25 pF	13 pF
Ultra3/Ultra160	15 pF	8 pF	25 pF	13 pF
Ultra320	13 pF	6.5 pF	21 pF (est.)	10 pF (est.)

TI terminators are designed with very tightly controlled capacitance on their signal lines. Between the positive and negative lines in a differential pair the difference is typically no more than 0.1 pF, and only 0.3 pF between pairs.

Multi-layer boards need to adhere to the 120-Ω impedance standard, including the connector and feedthroughs. Bus traces are normally run on the outer layers of the board with 4 mil etch and 4 mil spacing between the two lines in each differential pair, and a minimum of 8 mil spacing to adjacent pairs to minimize crosstalk. Microstrip technology is too low in impedance and should not be used—it is designed for 50 Ω rather than 120-Ω differential systems.

Decoupling capacitors should be installed as close as possible to the following input pins of the UCC5680:

TRMPWR: 4.7-μF capacitor to ground, 0.01-μF capacitor to ground (high-frequency, low ESR)

REG: 4.7-μF capacitor to ground, 0.01-μF capacitor to ground (high-frequency, low ESR)



UCC5680 9-LINE LVD ONLY SCSI TERMINATOR WITH INTEGRATED SPI-3 DELAYS

SLUS313B - APRIL 1999 - REVISED MARCH 2000

TYPICAL APPLICATION

PRODUCT PREVIEW

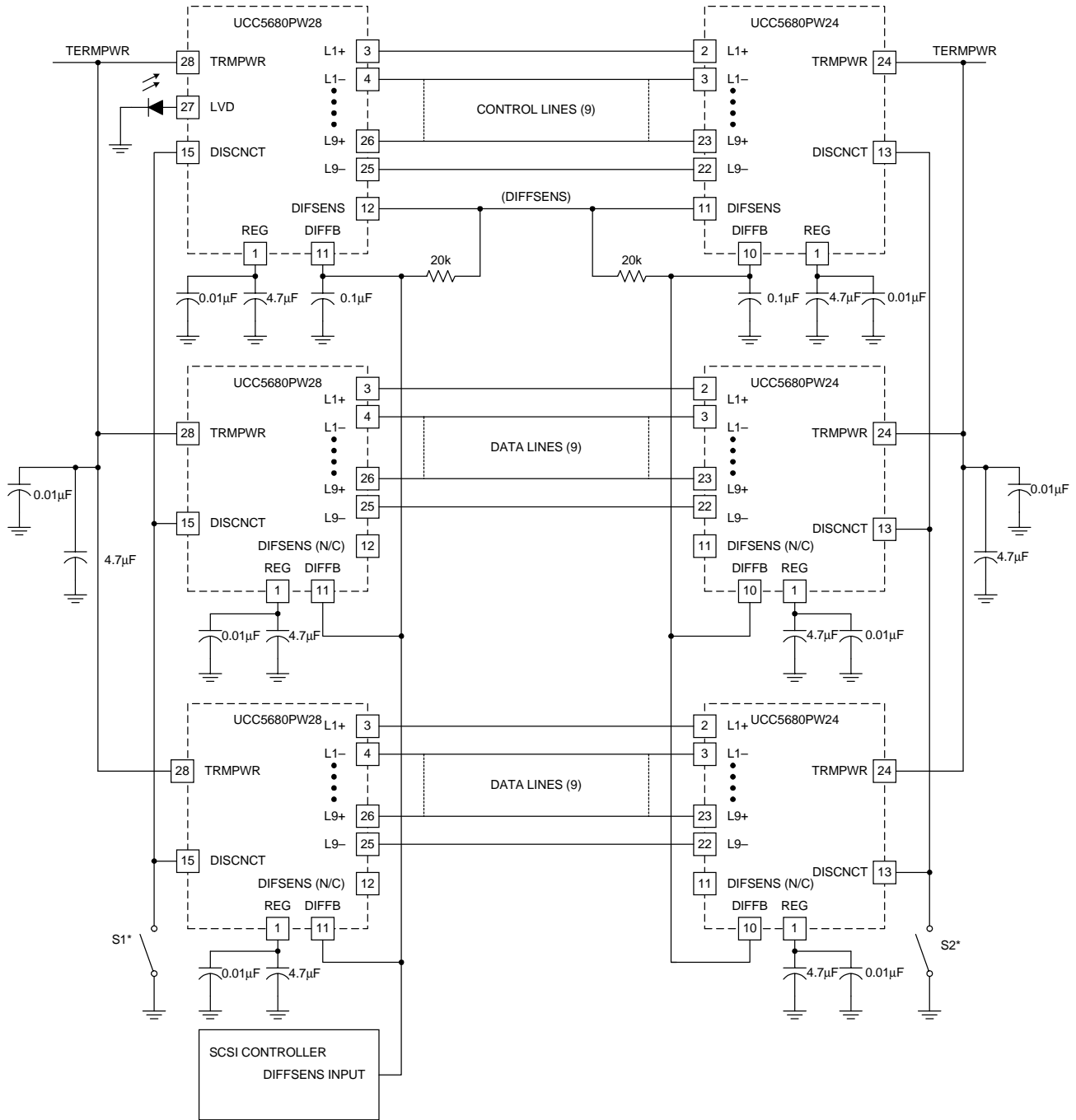

* CLOSE S1 AND S2 TO CONNECT TERMINATORS UDG-00005



POST OFFICE BOX 655303 • DALLAS, TEXAS 75265