

27 - Line SCSI Terminator With Split Reverse Disconnect

FEATURES

- Complies with SCSI, SCSI-2, SCSI-3, SPI and FAST-20 (Ultra) Standards
- 2.5pF Channel Capacitance During Disconnect
- 100 μ A Supply Current in Disconnect Mode
- 4V To 7V Operation
- 110 Ω Termination
- Completely Meets SCSI Hot Plugging
- -900mA Sourcing Current for Termination
- +500mA Sinking Current for Active Negation
- Logic Command Disconnects all Termination Lines
- Split Reverse Controls Lines 1 to 9 and 10 to 27 Separately
- Trimmed Impedance to 5%
- Current Limit and Thermal Shutdown Protection

DESCRIPTION

UCC5621 provides 27 lines of active termination for a SCSI (Small Computer Systems Interface) parallel bus. The SCSI standard recommends active termination at both ends of the cable.

The UCC5621 is ideal for high performance 5V SCSI systems. During disconnect the supply current is typically only 100 μ A, which makes the IC attractive for lower powered systems.

The UCC5621 features a split reverse disconnect allowing the user to control termination lines 10 to 27 with disconnect one, DISCNCT1, and control termination lines 1 to 9 with disconnect two, DISCNCT2.

The UCC5621 is designed with a low channel capacitance of 2.5pF, which eliminates effects on signal integrity from disconnected terminators at interim points on the bus.

The power amplifier output stage allows the UCC5621 to source full termination current and sink active negation current when all termination lines are actively negated.

The UCC5621, as with all Unitrode terminators, is completely hot pluggable and appears as high impedance at the terminating channels with $V_{TRMPWR} = 0V$ or open.

Internal circuit trimming is utilized, first to trim the 110 Ω impedance, and then most importantly, to trim the output current as close to the maximum SCSI-3 specification as possible, which maximizes noise margin in FAST-20 SCSI operation.

(continued)

BLOCK DIAGRAM

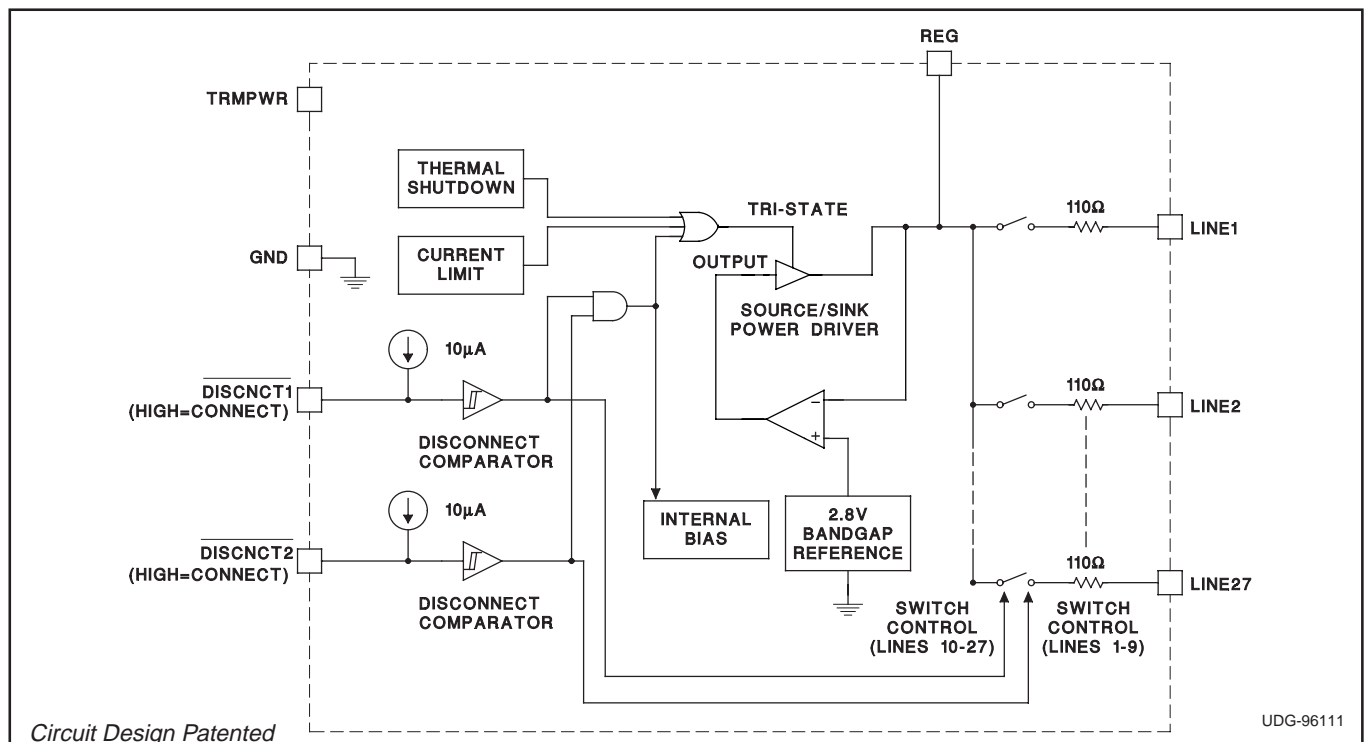

ABSOLUTE MAXIMUM RATINGS

TRMPWR Voltage	+7V
Signal Line Voltage	0V to +7V
Regulator Output Current	1.5A
Storage Temperature	-65°C to +150°C
Junction Temperature	-55°C to +150°C
Lead Temperature (Soldering, 10 Sec.)	+300°C

Currents are positive into, negative out of the specified terminal. Consult Packaging Section of Databook for thermal limitations and considerations of packages.

CONNECTION DIAGRAM

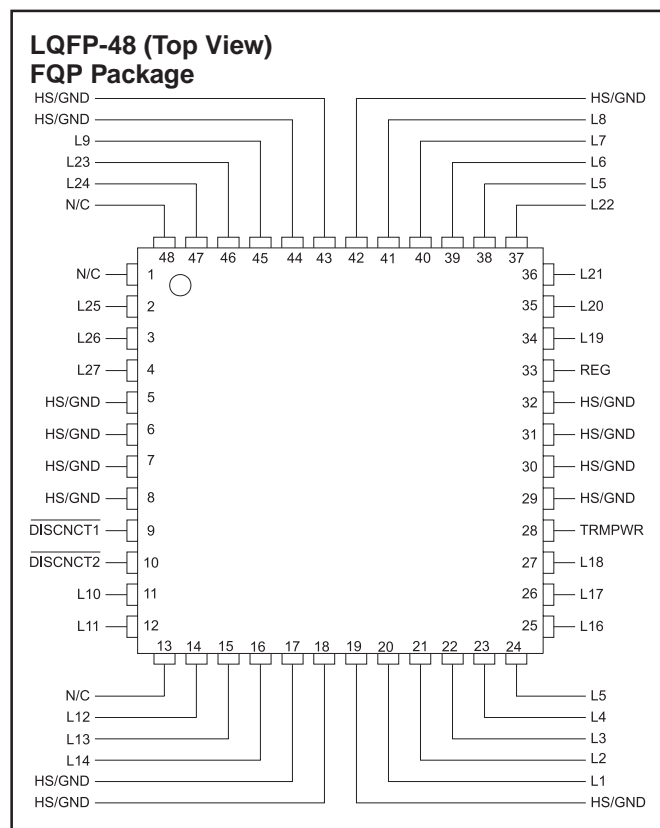
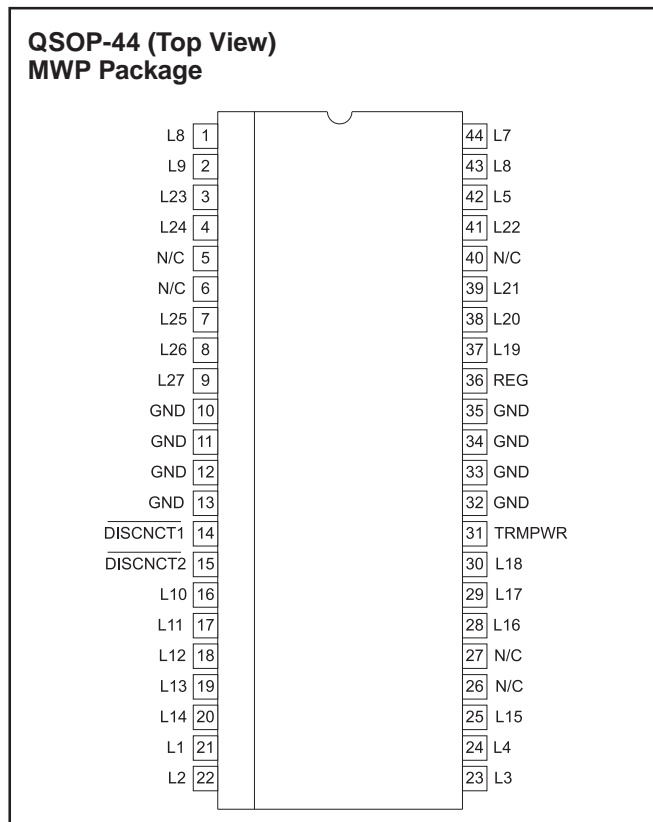

DESCRIPTION (cont.)

Other features include thermal shutdown and current limit. This device is offered in low thermal resistance versions of the industry standard 44 pin wide body QSOP (MWP) and 48 pin LQFP. Consult QSOP-44 and FQP-48 Packaging Diagrams for exact dimensions.

ELECTRICAL CHARACTERISTICS Unless otherwise stated, these specifications apply for $T_A = 0^\circ\text{C}$ to 70°C , $\text{TRMPWR} = 4.75\text{V}$, $\text{DISCNC1} = \text{DISCNC2} = 4.75\text{V}$, $T_A = T_J$.

PARAMETER	TEST CONDITIONS	MIN	TYP	MAX	UNITS
Supply Current Section					
TRMPWR Supply Current	All Termination Lines = Open		1	2	mA
	All Termination Lines = 0.2V		630	650	mA
Power Down Mode	DISCNC1 = DISCNC2 = 0V		100	200	μA

ELECTRICAL CHARACTERISTICS Unless otherwise stated, these specifications apply for $T_A = 0^\circ\text{C}$ to 70°C , $\text{TRMPWR} = 4.75\text{V}$, $\text{DISCNCT1} = \text{DISCNCT2} = 4.75\text{V}$, $T_A = T_J$.

PARAMETER	TEST CONDITIONS	MIN	TYP	MAX	UNITS
Output Section (Termination Lines)					
Termination Impedance	(Note 3)	104.5	110	115.5	Ω
Output High Voltage	(Note 1)	2.6	2.8	3.0	V
Max Output Current	$V_{\text{LINE}} = 0.2\text{V}$, $T_J = 25^\circ\text{C}$	-22.1	-23.3	-24	mA
	$V_{\text{LINE}} = 0.2\text{V}$	-20.7	-23.3	-24	mA
	$V_{\text{LINE}} = 0.2\text{V}$, $\text{TRMPWR} = 4\text{V}$, $T_J = 25^\circ\text{C}$ (Note 1)	-21	-23	-24	mA
	$V_{\text{LINE}} = 0.2\text{V}$, $\text{TRMPWR} = 4\text{V}$ (Note 1)	-20	-23	-24	mA
	$V_{\text{LINE}} = 0.5\text{V}$			-22.4	mA
Output Leakage	$\text{DISCNCT1} = \text{DISCNCT2} = 0\text{V}$, $\text{TRMPWR} = 0\text{V}$ to 5.25V		10	400	nA
Output Capacitance	$\text{DISCNCT1} = \text{DISCNCT2} = 0\text{V}$ (Note 2)		2.5	4	pF
Regulator Section					
Regulator Output Voltage		2.6	2.8	3.0	V
Drop Out Voltage	All Termination Lines = 0.2V		0.4	0.8	V
Short Circuit Current	$V_{\text{REG}} = 0\text{V}$	-650	-900	-1300	mA
Sinking Current Capability	$V_{\text{REG}} = 3.5\text{V}$	300	500	900	mA
Thermal Shutdown			170		$^\circ\text{C}$
Thermal Shutdown Hysteresis			10		$^\circ\text{C}$
Disconnect Section					
Disconnect Threshold DISCNCT1	Controls Lines 10 to 27	0.8	1.5	2.0	V
Input Current DISCNCT1	$\text{DISCNCT1} = 0\text{V}$		-10	-30	μA
Disconnect Threshold DISCNCT2	Controls Lines 1 to 9	0.8	1.5	2	V
Input Current DISCNCT2	$\text{DISCNCT2} = 0\text{V}$		-10	-30	μA

Note 1: Measuring each termination line while other 26 are low (0.2V).

Note 2: Guaranteed by design. Not 100% tested in production.

Note 3: Tested by measuring I_{OUT} with $V_{\text{OUT}} = 0.2\text{V}$ and V_{OUT} with no load, then calculate:

$$Z = \frac{V_{\text{OUT N.L.}} - 0.2\text{V}}{I_{\text{OUT at } 0.2\text{V}}}$$

PIN DESCRIPTIONS

DISCNCT1: Disconnect one controls termination lines L10 – L27. Taking this pin low causes termination lines L10 – L27 to become high impedance, taking this pin high or leaving it open allows the channels to provide normal termination.

DISCNCT2 : Disconnect two controls termination lines L1 – L9. Taking this pin low causes termination lines L1 – L9 to become high impedance. Taking this pin high or leaving it open allows the channels to provide normal termination. Taking both disconnect pins low will put the chip in to sleep mode where it will be in low-power mode.

GND: Ground reference for the IC.

L1 - L27: 110Ω termination channels.

REG: Output of the internal 2.7V regulator.

TRMPWR: Power for the IC.

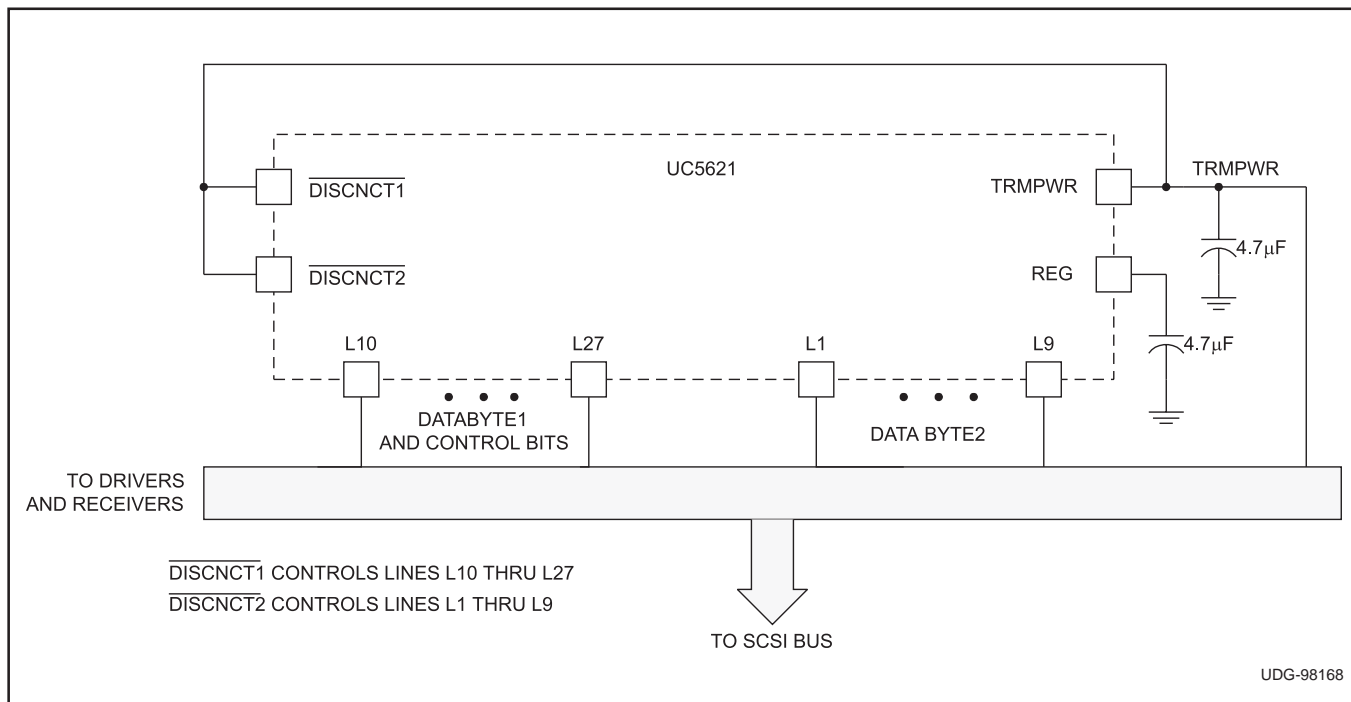

Figure 1. Typical Wide SCSI Bus Configuration Using the UCC5621

IMPORTANT NOTICE

Texas Instruments and its subsidiaries (TI) reserve the right to make changes to their products or to discontinue any product or service without notice, and advise customers to obtain the latest version of relevant information to verify, before placing orders, that information being relied on is current and complete. All products are sold subject to the terms and conditions of sale supplied at the time of order acknowledgement, including those pertaining to warranty, patent infringement, and limitation of liability.

TI warrants performance of its semiconductor products to the specifications applicable at the time of sale in accordance with TI's standard warranty. Testing and other quality control techniques are utilized to the extent TI deems necessary to support this warranty. Specific testing of all parameters of each device is not necessarily performed, except those mandated by government requirements.

CERTAIN APPLICATIONS USING SEMICONDUCTOR PRODUCTS MAY INVOLVE POTENTIAL RISKS OF DEATH, PERSONAL INJURY, OR SEVERE PROPERTY OR ENVIRONMENTAL DAMAGE ("CRITICAL APPLICATIONS"). TI SEMICONDUCTOR PRODUCTS ARE NOT DESIGNED, AUTHORIZED, OR WARRANTED TO BE SUITABLE FOR USE IN LIFE-SUPPORT DEVICES OR SYSTEMS OR OTHER CRITICAL APPLICATIONS. INCLUSION OF TI PRODUCTS IN SUCH APPLICATIONS IS UNDERSTOOD TO BE FULLY AT THE CUSTOMER'S RISK.

In order to minimize risks associated with the customer's applications, adequate design and operating safeguards must be provided by the customer to minimize inherent or procedural hazards.

TI assumes no liability for applications assistance or customer product design. TI does not warrant or represent that any license, either express or implied, is granted under any patent right, copyright, mask work right, or other intellectual property right of TI covering or relating to any combination, machine, or process in which such semiconductor products or services might be or are used. TI's publication of information regarding any third party's products or services does not constitute TI's approval, warranty or endorsement thereof.