

74AC1138 3-LINE TO 8-LINE DECODER/DEMULTIPLEXER

SCAS042B – MAY 1988 – REVISED APRIL 1996

- Designed Specifically for High-Speed Memory Decoders and Data Transmission Systems
- Incorporates Three Enable Inputs to Simplify Cascading and/or Data Reception
- Center-Pin V_{CC} and GND Configurations Minimize High-Speed Switching Noise
- EPIC™ (Enhanced-Performance Implanted CMOS) 1- μ m Process
- 500-mA Typical Latch-Up Immunity at 125°C
- Package Options Include Plastic Small-Outline (D) and Thin Shrink Small-Outline (PW) Packages, and Standard Plastic 300-mil DIPs (N)

D, N, OR PW PACKAGE
(TOP VIEW)

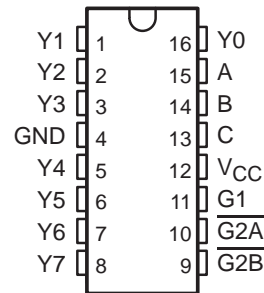

description

The 74AC1138 circuit is designed to be used in high-performance memory-decoding or data-routing applications requiring very short propagation delay times. In high-performance memory systems, this decoder can be used to minimize the effects of system decoding. When employed with high-speed memories utilizing a fast enable circuit, the delay times of this decoder and the enable time of the memory are usually less than the typical access time of the memory. This means that the effective system delay introduced by the decoder is negligible.

The conditions at the binary-select (A, B, C) inputs and the three enable ($G1$, $\overline{G2A}$, $\overline{G2B}$) inputs select one of eight output lines. Two active-low and one active-high enable inputs reduce the need for external gates or inverters when expanding. A 24-line decoder can be implemented without external inverters and a 32-line decoder requires only one inverter. An enable input can be used as a data input for demultiplexing applications.

The 74AC1138 is characterized for operation from -40°C to 85°C .

FUNCTION TABLE

ENABLE INPUTS			SELECT INPUTS			OUTPUTS							
G1	$\overline{G2A}$	$\overline{G2B}$	C	B	A	Y0	Y1	Y2	Y3	Y4	Y5	Y6	Y7
X	H	X	X	X	X	H	H	H	H	H	H	H	H
X	X	H	X	X	X	H	H	H	H	H	H	H	H
L	X	X	X	X	X	H	H	H	H	H	H	H	H
H	L	L	L	L	L	L	H	H	H	H	H	H	H
H	L	L	L	L	H	H	L	H	H	H	H	H	H
H	L	L	L	H	L	H	H	L	H	H	H	H	H
H	L	L	L	H	H	H	H	H	L	H	H	H	H
H	L	L	H	L	H	H	H	H	H	L	H	H	H
H	L	L	H	H	L	H	H	H	H	H	L	H	H
H	L	L	H	H	H	H	H	H	H	H	H	L	H
H	L	L	H	H	H	H	H	H	H	H	H	H	L



Please be aware that an important notice concerning availability, standard warranty, and use in critical applications of Texas Instruments semiconductor products and disclaimers thereto appears at the end of this data sheet.

EPIC is a trademark of Texas Instruments Incorporated.

PRODUCTION DATA information is current as of publication date. Products conform to specifications per the terms of Texas Instruments standard warranty. Production processing does not necessarily include testing of all parameters.

**TEXAS
INSTRUMENTS**

POST OFFICE BOX 655303 • DALLAS, TEXAS 75265
POST OFFICE BOX 1443 • HOUSTON, TEXAS 77251-1443

Copyright © 1996, Texas Instruments Incorporated

74AC1138 3-LINE TO 8-LINE DECODER/DEMULTIPLEXER

SCAS042B – MAY 1988 – REVISED APRIL 1996

logic symbols (alternatives)†

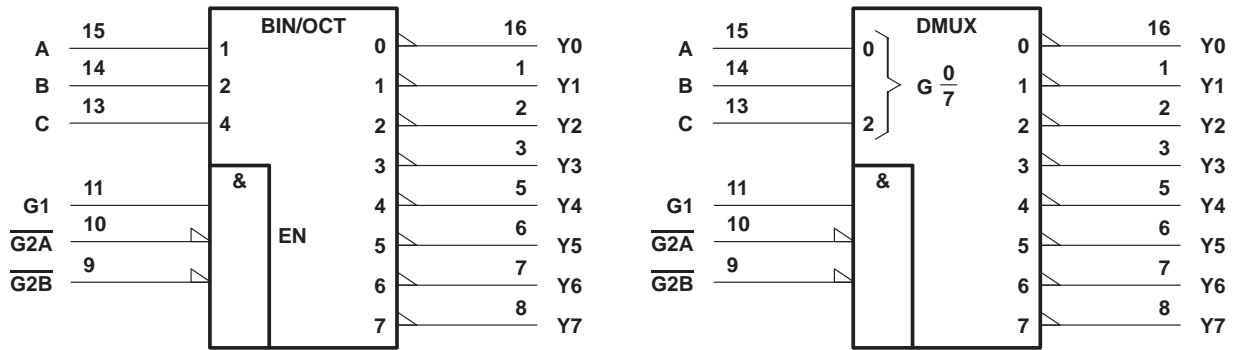

† These symbols are in accordance with ANSI/IEEE Std 91-1984 and IEC Publication 617-12.

logic diagram (positive logic)

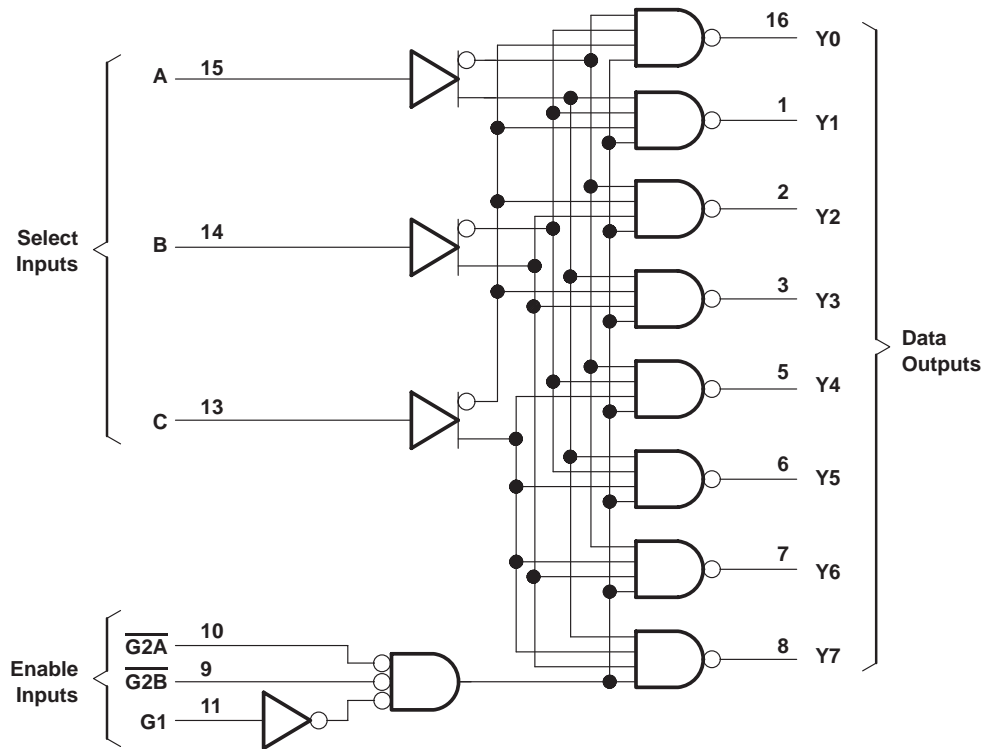

74AC11138

3-LINE TO 8-LINE DECODER/DEMULTIPLEXER

SCAS042B – MAY 1988 – REVISED APRIL 1996

absolute maximum ratings over operating free-air temperature range (unless otherwise noted)†

Supply voltage range, V_{CC}	–0.5 V to 7 V
Input voltage range, V_I (see Note 1)	–0.5 V to $V_{CC} + 0.5$ V
Output voltage range, V_O (see Note 1)	–0.5 V to $V_{CC} + 0.5$ V
Input clamp current, I_{IK} ($V_I < 0$ or $V_I > V_{CC}$)	±20 mA
Output clamp current, I_{OK} ($V_O < 0$ or $V_O > V_{CC}$)	±50 mA
Continuous output current, I_O ($V_O = 0$ to V_{CC})	±50 mA
Continuous current through V_{CC} or GND	±200 mA
Maximum power dissipation at $T_A = 55^\circ\text{C}$ (in still air) (see Note 2):	D package
	N package
	PW package
Storage temperature range, T_{stg}	–65°C to 150°C

† Stresses beyond those listed under “absolute maximum ratings” may cause permanent damage to the device. These are stress ratings only, and functional operation of the device at these or any other conditions beyond those indicated under “recommended operating conditions” is not implied. Exposure to absolute-maximum-rated conditions for extended periods may affect device reliability.

- NOTES: 1. The input and output voltage ratings may be exceeded if the input and output current ratings are observed.
 2. The maximum package power dissipation is calculated using a junction temperature of 150°C and a board trace length of 750 mils, except for the N package, which has a trace length of zero.

recommended operating conditions

		MIN	NOM	MAX	UNIT
V_{CC}	Supply voltage	3	5	5.5	V
V_{IH}	High-level input voltage	$V_{CC} = 3$ V	2.1		V
		$V_{CC} = 4.5$ V	3.15		
		$V_{CC} = 5.5$ V	3.85		
V_{IL}	Low-level input voltage	$V_{CC} = 3$ V		0.9	V
		$V_{CC} = 4.5$ V		1.35	
		$V_{CC} = 5.5$ V		1.65	
V_I	Input voltage	0		V_{CC}	V
V_O	Output voltage	0		V_{CC}	V
I_{OH}	High-level output current	$V_{CC} = 3$ V		–4	mA
		$V_{CC} = 4.5$ V		–24	
		$V_{CC} = 5.5$ V		–24	
I_{OL}	Low-level output current	$V_{CC} = 3$ V		12	mA
		$V_{CC} = 4.5$ V		24	
		$V_{CC} = 5.5$ V		24	
$\Delta t/\Delta v$	Input transition rise or fall rate	0		10	ns/V
T_A	Operating free-air temperature	–40		85	°C



74AC11138

3-LINE TO 8-LINE DECODER/DEMULTIPLEXER

SCAS042B – MAY 1988 – REVISED APRIL 1996

electrical characteristics over recommended operating free-air temperature range (unless otherwise noted)

PARAMETER	TEST CONDITIONS	V _{CC}	T _A = 25°C			MIN	MAX	UNIT
			MIN	TYP	MAX			
V _{OH}	I _{OH} = -50 μA	3 V	2.9			2.9		V
		4.5 V	4.4			4.4		
		5.5 V	5.4			5.4		
	I _{OH} = -4 mA	3 V	2.58			2.48		
		4.5 V	3.94			3.8		
		5.5 V	4.94			4.8		
I _{OH} = -75 mA†	5.5 V				3.85			
V _{OL}	I _{OL} = 50 μA	3 V	0.1			0.1		V
		4.5 V	0.1			0.1		
		5.5 V	0.1			0.1		
	I _{OL} = 12 mA	3 V	0.36			0.44		
		4.5 V	0.36			0.44		
		5.5 V	0.36			0.44		
I _{OL} = 75 mA†	5.5 V				1.65			
I _I	V _I = V _{CC} or GND	5.5 V	±0.1			±1		μA
I _{CC}	V _I = V _{CC} or GND, I _O = 0	5.5 V	4			40		μA
C _i	V _I = V _{CC} or GND	5 V	3.5					pF

† Not more than one output should be tested at a time, and the duration of the test should not exceed 10 ms.

switching characteristics over recommended operating free-air temperature range, V_{CC} = 3.3 V ± 0.3 V (unless otherwise noted) (see Figure 1)

PARAMETER	FROM (INPUT)	TO (OUTPUT)	T _A = 25°C			MIN	MAX	UNIT
			MIN	TYP	MAX			
t _{PLH}	A, B, C	Any Y	1.5	8.3	10.2	1.5	11.4	ns
t _{PHL}			1.5	8.9	10.9	1.5	12.2	
t _{PLH}	G1	Any Y	1.5	7.2	9.2	1.5	10.2	ns
t _{PHL}			1.5	7.3	9.4	1.5	10.5	
t _{PLH}	$\overline{G2A}, \overline{G2B}$	Any Y	1.5	8.2	10.4	1.5	11.5	ns
t _{PHL}			1.5	8.3	10.4	1.5	11.6	

switching characteristics over recommended operating free-air temperature range, V_{CC} = 5 V ± 0.5 V (unless otherwise noted) (see Figure 1)

PARAMETER	FROM (INPUT)	TO (OUTPUT)	T _A = 25°C			MIN	MAX	UNIT
			MIN	TYP	MAX			
t _{PLH}	A, B, C	Any Y	1.5	5.7	7.3	1.5	8.1	ns
t _{PHL}			1.5	6.2	7.9	1.5	8.8	
t _{PLH}	G1	Any Y	1.5	5.1	6.9	1.5	7.5	ns
t _{PHL}			1.5	5.2	6.9	1.5	7.7	
t _{PLH}	$\overline{G2A}, \overline{G2B}$	Any Y	1.5	5.8	7.6	1.5	8.3	ns
t _{PHL}			1.5	5.6	7.5	1.5	8.3	



74AC1138 3-LINE TO 8-LINE DECODER/DEMULTIPLEXER

SCAS042B – MAY 1988 – REVISED APRIL 1996

operating characteristics, $V_{CC} = 5\text{ V}$, $T_A = 25^\circ\text{C}$

PARAMETER	TEST CONDITIONS	TYP	UNIT
C_{pd} Power dissipation capacitance per gate	$C_L = 50\text{ pF}$, $f = 1\text{ MHz}$	51	μF

PARAMETER MEASUREMENT INFORMATION

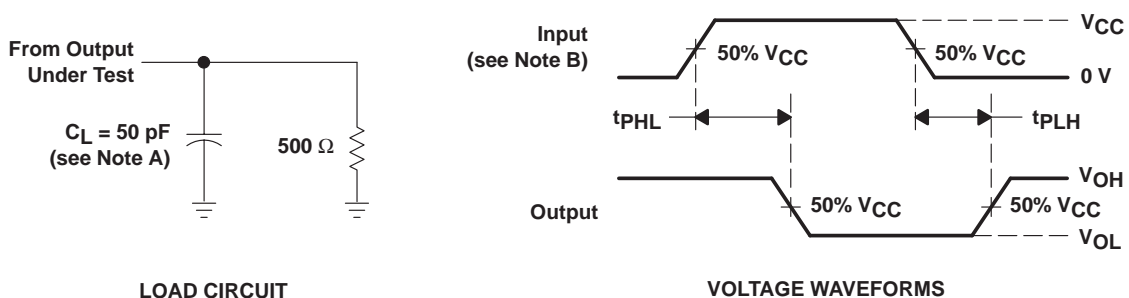

- NOTES: A. C_L includes probe and jig capacitance.
 B. Input pulses are supplied by generators having the following characteristics: $PRR \leq 1\text{ MHz}$, $Z_O = 50\ \Omega$, $t_r = 3\text{ ns}$, $t_f = 3\text{ ns}$.
 C. The outputs are measured one at a time with one input transition per measurement.

Figure 1. Load Circuit and Voltage Waveforms



74AC11138

3-LINE TO 8-LINE DECODER/DEMULTIPLEXER

SCAS042B – MAY 1988 – REVISED APRIL 1996

APPLICATION INFORMATION

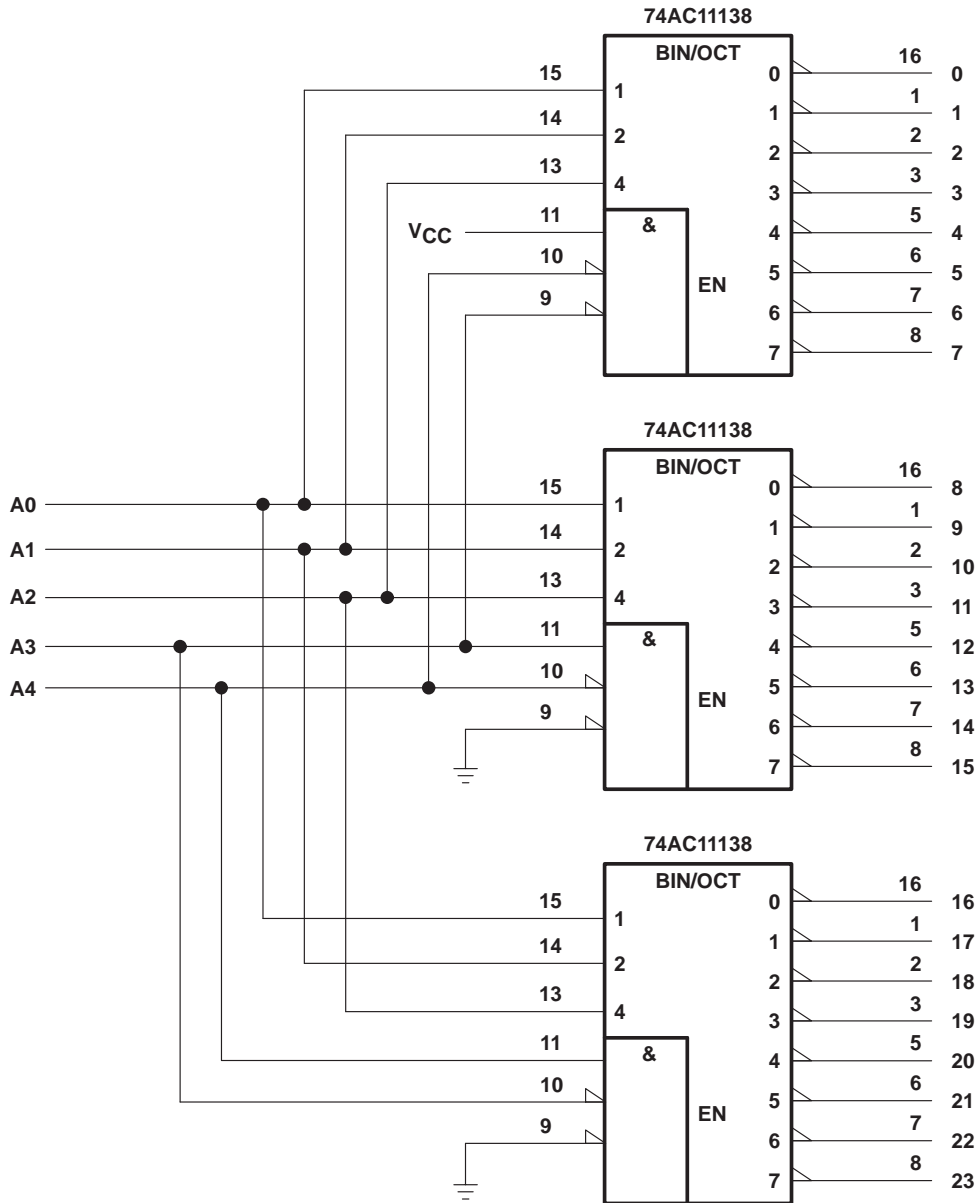

Figure 2. 24-Bit Decoding Scheme



POST OFFICE BOX 655303 • DALLAS, TEXAS 75265
 POST OFFICE BOX 1443 • HOUSTON, TEXAS 77251-1443

74AC1138 3-LINE TO 8-LINE DECODER/DEMULTIPLEXER

SCAS042B – MAY 1988 – REVISED APRIL 1996

APPLICATION INFORMATION

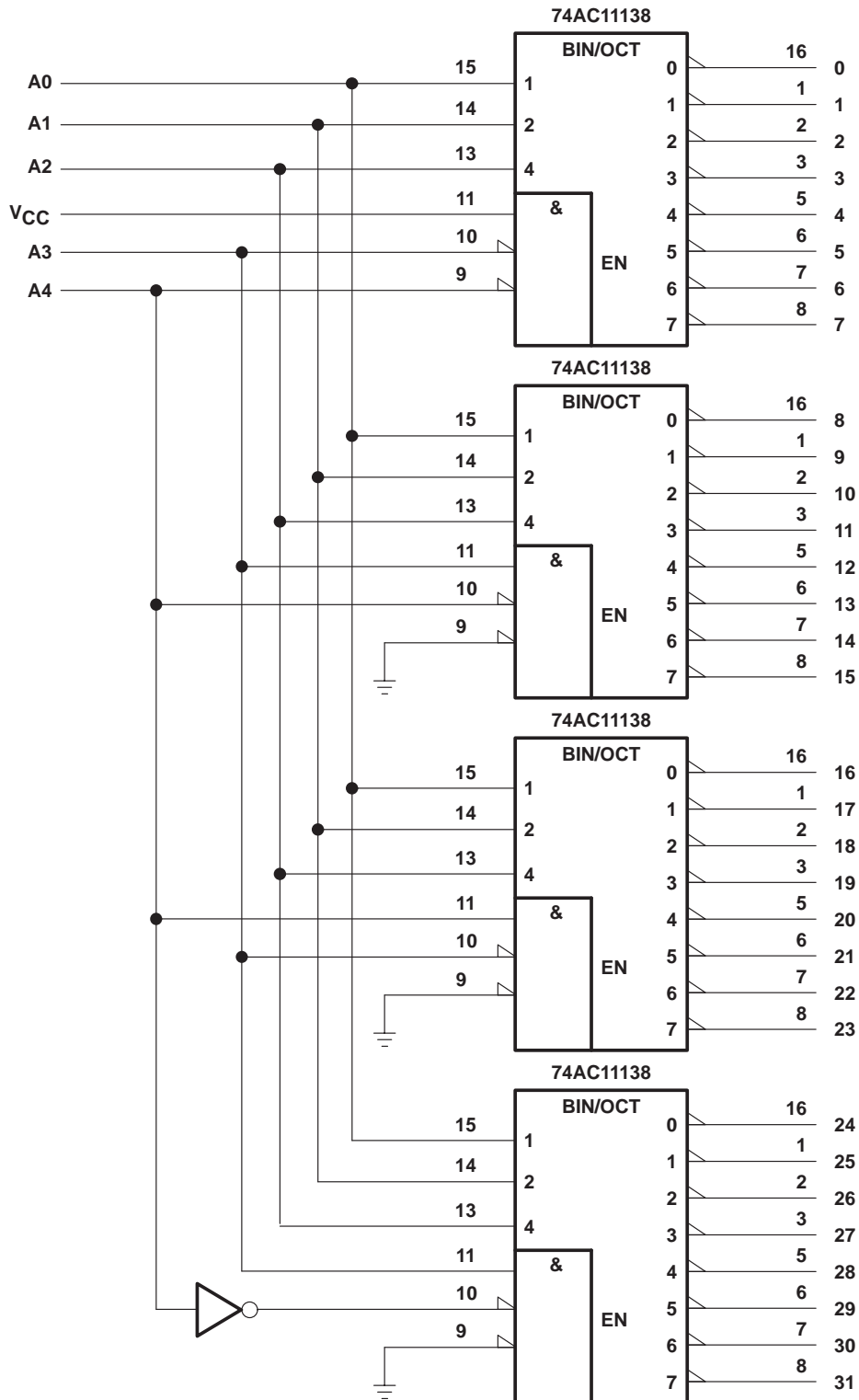

Figure 3. 32-Bit Decoding Scheme



IMPORTANT NOTICE

Texas Instruments and its subsidiaries (TI) reserve the right to make changes to their products or to discontinue any product or service without notice, and advise customers to obtain the latest version of relevant information to verify, before placing orders, that information being relied on is current and complete. All products are sold subject to the terms and conditions of sale supplied at the time of order acknowledgement, including those pertaining to warranty, patent infringement, and limitation of liability.

TI warrants performance of its semiconductor products to the specifications applicable at the time of sale in accordance with TI's standard warranty. Testing and other quality control techniques are utilized to the extent TI deems necessary to support this warranty. Specific testing of all parameters of each device is not necessarily performed, except those mandated by government requirements.

CERTAIN APPLICATIONS USING SEMICONDUCTOR PRODUCTS MAY INVOLVE POTENTIAL RISKS OF DEATH, PERSONAL INJURY, OR SEVERE PROPERTY OR ENVIRONMENTAL DAMAGE ("CRITICAL APPLICATIONS"). TI SEMICONDUCTOR PRODUCTS ARE NOT DESIGNED, AUTHORIZED, OR WARRANTED TO BE SUITABLE FOR USE IN LIFE-SUPPORT DEVICES OR SYSTEMS OR OTHER CRITICAL APPLICATIONS. INCLUSION OF TI PRODUCTS IN SUCH APPLICATIONS IS UNDERSTOOD TO BE FULLY AT THE CUSTOMER'S RISK.

In order to minimize risks associated with the customer's applications, adequate design and operating safeguards must be provided by the customer to minimize inherent or procedural hazards.

TI assumes no liability for applications assistance or customer product design. TI does not warrant or represent that any license, either express or implied, is granted under any patent right, copyright, mask work right, or other intellectual property right of TI covering or relating to any combination, machine, or process in which such semiconductor products or services might be or are used. TI's publication of information regarding any third party's products or services does not constitute TI's approval, warranty or endorsement thereof.