

NV Controller With Battery Monitor

Features

- Power monitoring and switching for nonvolatile control of SRAMs
- Write-protect control
- Battery-low and battery-fail indicators
- Reset output for system power-on reset
- Input decoder for control of up to 2 banks of SRAM
- 3-volt primary cell input
- 3-volt rechargeable battery input/output

General Description

The CMOS bq2203A SRAM Nonvolatile Controller With Battery Monitor provides all the necessary functions for converting one or two banks of standard CMOS SRAM into nonvolatile read/write memory. The bq2203A is compatible with the Personal Computer Memory Card International Association (PCMCIA) recommendations for battery-backed static RAM memory cards.

A precision comparator monitors the 5V VCC input for an out-of-tolerance condition. When out of tolerance is detected, the two conditioned chip-enable outputs are forced inactive to write-protect banks of SRAM.

Power for the external SRAMs is switched from the VCC supply to the battery-backup supply as VCC decays. On a subsequent power-up, the VOUT supply is automatically switched from the backup supply to the VCC supply. The external SRAMs are write-protected until a power-valid condition exists. The reset output provides power-fail and power-on resets for the system. The battery monitor indicates battery-low and battery-fail conditions.

During power-valid operation, the input decoder selects one of two banks of SRAM.

Pin Connections

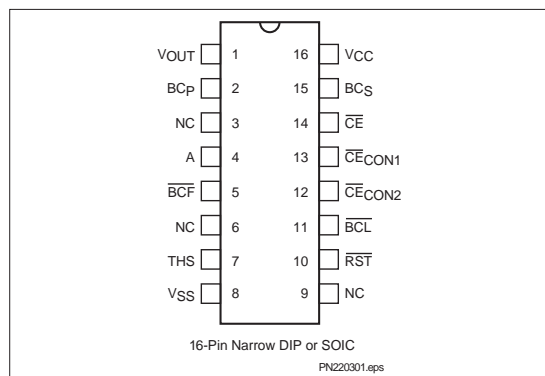

Pin Names

VOUT	Supply output
RST	Reset output
THS	Threshold select input
CE	chip-enable active low input
CECON1, CECON2	Conditioned chip-enable outputs
A	Bank select input
BCF	Battery fail push-pull output
BCL	Battery low push-pull output
BCP	3V backup supply input
BCS	3V rechargeable backup supply input/output
NC	No connect
VCC	5-volt supply input
VSS	Ground

Functional Description

Two banks of CMOS static RAM can be battery-backed using the VOUT and the conditioned chip-enable output pins from the bq2203A. As the voltage input VCC slews down during a power failure, the two conditioned chip-enable outputs, CECON1 and CECON2, are forced inactive independent of the chip-enable input CE.

This activity unconditionally write-protects external SRAM as VCC falls to an out-of-tolerance threshold V_{PF}D. V_{PF}D is selected by the threshold select input pin, THS. If THS is tied to VSS, the power-fail detection occurs at 4.62V typical for 5% supply operation.

If THS is tied to VCC, power-fail detection occurs at 4.37V typical for 10% supply operation. The THS pin must be tied to VSS or VCC for proper operation.

If a memory access is in process to any of the two external banks of SRAM during power-fail detection, that memory cycle continues to completion before the memory is write-protected. If the memory cycle is not terminated within time t_{WPT} (150μs maximum), the two chip-enable outputs are unconditionally driven high, write-protecting the controlled SRAMs.

bq2203A

As the supply continues to fall past V_{PFD} , an internal switching device forces V_{OUT} to the external backup energy source. $\overline{CECON1}$ and $\overline{CECON2}$ are held high by the V_{OUT} energy source.

During power-up, V_{OUT} is switched back to the 5V supply as V_{CC} rises above the backup cell input voltage sourcing V_{OUT} . Outputs $\overline{CECON1}$ and $\overline{CECON2}$ are held inactive for time t_{CER} (120ms maximum) after the power supply has reached V_{PFD} , independent of the \overline{CE} input, to allow for processor stabilization.

During power-valid operation, the \overline{CE} input is passed through to one of the two \overline{CECON} outputs with a propagation delay of less than 10ns. The \overline{CE} input is output on one of the two \overline{CECON} output pins depending on the level of bank select input A, as shown in the Truth Table.

Bank select input A is usually tied to a high-order address pin so that a large nonvolatile memory can be designed using lower-density memory devices. Nonvolatility and decoding are achieved by hardware hookup as shown in Figure 1.

The reset output (\overline{RST}) goes active within t_{PFD} (150 μ s maximum) after V_{PFD} , and remains active for a minimum of 40ms (120ms maximum) after power returns valid. The \overline{RST} output can be used as the power-on reset for a microprocessor. Access to the external RAM may begin when \overline{RST} returns inactive.

Energy Cell Inputs—BCP, BCS

Two backup energy source inputs are provided on the bq2203A—a primary cell BCP and a secondary cell BCS. The primary cell input is designed to accept any 3V primary battery (non-rechargeable), typically some type of lithium chemistry. If a primary cell is not to be used, the BCP pin should be tied to V_{SS} . The secondary cell input BCS is designed to accept constant-voltage current-limited rechargeable cells.

During normal 5V power valid operation, 3.3V typical is output on the BCS pin and is current-limited internally. Although this charging method can be used with various 3V secondary cells, it is specifically designed for a Panasonic VL (vanadium-lithium) series of rechargeable cells.

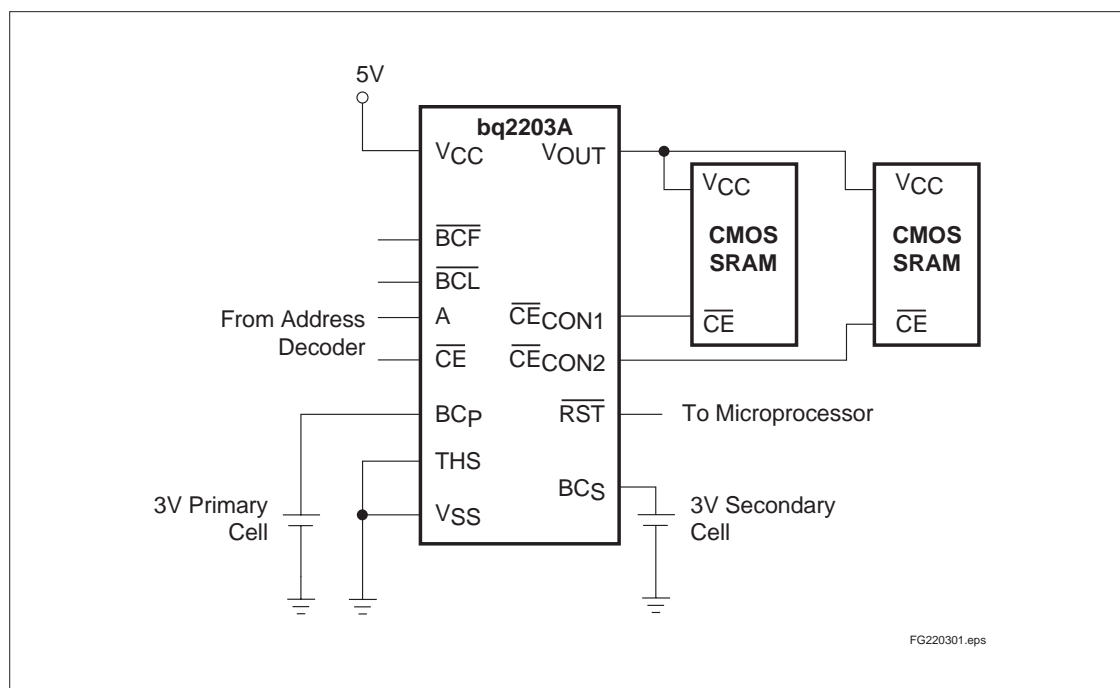

Figure 1. Hardware Hookup (5% Supply Operation)

If a secondary cell is not to be used, the BC_S pin must be tied directly to V_{SS}.

V_{CC} falling below V_{PF_D} starts the comparison of BC_S and BC_P. The BC input comparison continues until V_{CC} rises above V_{SO}. Power to V_{OUT} begins with BC_S and switches to BC_P only when BC_S is less than BC_P minus V_{BSO}. The controller alternates to the higher BC voltage when the difference between the BC input voltages is greater than V_{BSO}. Alternating the backup batteries allows one-at-a-time battery replacement and efficient use of both backup batteries.

To prevent battery drain when there is no valid data to retain, V_{OUT}, $\overline{\text{CECON1}}$, and $\overline{\text{CECON2}}$ are internally isolated from BC_P and BC_S by either of two methods:

- Initial connection of a battery to BC_P or BC_S (V_{CC} grounded) or
- Presentation of an isolation signal on $\overline{\text{CE}}$.

A valid isolation signal requires $\overline{\text{CE}}$ low as V_{CC} crosses both V_{PF_D} and V_{SO} during a power-down. See Figure 2. Between these two points in time, $\overline{\text{CE}}$ must be brought to V_{CC}*(0.48 to 0.52) and held for at least 700ns. The isolation signal is invalid if $\overline{\text{CE}}$ exceeds V_{CC}*0.54 at any point between V_{CC} crossing V_{PF_D} and V_{SO}.

The isolation function is terminated and the appropriate battery is connected to V_{OUT}, $\overline{\text{CECON1}}$, and $\overline{\text{CECON2}}$ by powering V_{CC} up through V_{PF_D}.

Battery Monitor— $\overline{\text{BCL}}$, $\overline{\text{BCF}}$

As V_{CC} rises past V_{PF_D}, the battery voltage on BC_P is compared with a dual-voltage reference. The result of this comparison is latched internally, and output after t_{BC} when V_{CC} rises past V_{PF_D}. If the battery voltage on BC_P is below V_{BL}, then $\overline{\text{BCL}}$ is asserted low. If the battery is below V_{BF}, then $\overline{\text{BCL}}$ and $\overline{\text{BCF}}$ are asserted low. The results of this comparison remain latched until V_{CC} falls below V_{PF_D}.

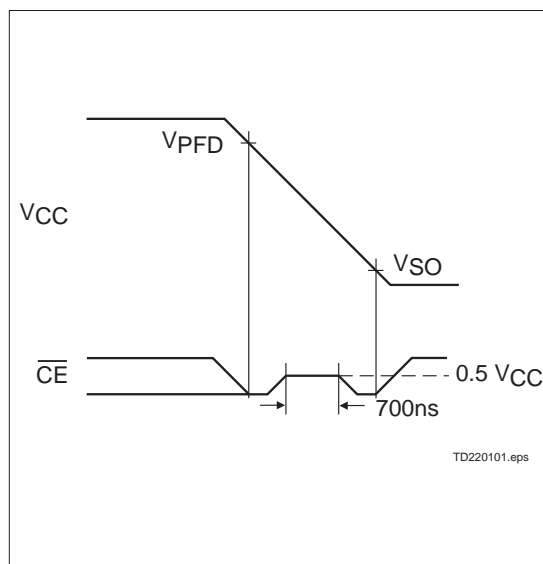

Figure 2. Battery Isolation Signal

Truth Table

Input		Output	
$\overline{\text{CE}}$	A	$\overline{\text{CECON1}}$	$\overline{\text{CECON2}}$
H	X	H	H
L	L	L	H
L	H	H	L

bq2203A

Absolute Maximum Ratings

Symbol	Parameter	Value	Unit	Conditions
V _{CC}	DC voltage applied on V _{CC} relative to V _{SS}	-0.3 to +7.0	V	
V _T	DC voltage applied on any pin excluding V _{CC} relative to V _{SS}	-0.3 to +7.0	V	V _T ≤ V _{CC} + 0.3
T _{OPR}	Operating temperature	0 to 70	°C	Commercial
		-40 to +85	°C	"N" Industrial
T _{STG}	Storage temperature	-55 to +125	°C	
T _{BIAS}	Temperature under bias	-40 to +85	°C	
T _{SOLDER}	Soldering temperature	260	°C	For 10 seconds
I _{OUT}	V _{OUT} current	200	mA	

Note: Permanent device damage may occur if **Absolute Maximum Ratings** are exceeded. Functional operation should be limited to the Recommended DC Operating Conditions detailed in this data sheet. Exposure to conditions beyond the operational limits for extended periods of time may affect device reliability.

Recommended DC Operating Conditions (T_A = T_{OPR})

Symbol	Parameter	Minimum	Typical	Maximum	Unit	Notes
V _{CC}	Supply voltage	4.75	5.0	5.5	V	THS = V _{SS}
		4.50	5.0	5.5	V	THS = V _{CC}
V _{BCP}	Backup cell input voltage	2.0	-	4.0	V	V _{CC} < V _{BC}
V _{BSC}		2.0	-	4.0	V	V _{CC} < V _{BC}
V _{SS}	Supply voltage	0	0	0	V	
V _{IL}	Input low voltage	-0.3	-	0.8	V	
V _{IH}	Input high voltage	2.2	-	V _{CC} + 0.3	V	
THS	Threshold select	-0.3	-	V _{CC} + 0.3	V	

Note: Typical values indicate operation at T_A = 25°C, V_{CC} = 5V.

DC Electrical Characteristics ($T_A = T_{OPR}$, $V_{CC} = 5V \pm 10\%$)

Symbol	Parameter	Minimum	Typical	Maximum	Unit	Conditions/Notes
I _{LI}	Input leakage current	-	-	± 1	μA	V _{IN} = V _{SS} to V _{CC}
V _{OH}	Output high voltage	2.4	-	-	V	I _{OH} = -2.0mA
V _{OH} B	V _{OH} , backup supply	V _{BC} - 0.3	-	-	V	V _{BC} > V _{CC} , I _{OH} = -10μA
V _{OL}	Output low voltage	-	-	0.4	V	I _{OL} = 4.0mA
I _{CC}	Operating supply current	-	3	6	mA	No load on outputs
V _{PF} D	Power-fail detect voltage	4.55	4.62	4.75	V	THS = V _{SS}
		4.30	4.37	4.50	V	THS = V _{CC}
V _{SO}	Supply switch-over voltage	-	V _{BC}	-	V	
I _{CC} DR	Data-retention mode current	-	-	100	nA	No load on outputs
V _{BC}	Active backup cell voltage	-	V _{BCS}	-	V	V _{BCS} > V _{BCP} + V _B SO
		-	V _{BCP}	-	V	V _{BCP} > V _{BCS} + V _B SO
V _B SO	Battery switch-over voltage	0.25	0.4	0.6	V	
R _{BCS}	BCS charge output internal resistance	500	1000	1750	Ω	V _{BCSO} ≥ 3.0V
V _{BC} SO	BCS charge output voltage	3.15	3.3	3.5	V	V _{CC} > V _{PF} D, \overline{RST} inactive, full charge or no load
I _{OUT} 1	V _{OUT} current	-	-	160	mA	V _{OUT} ≥ V _{CC} - 0.3V
I _{OUT} 2	V _{OUT} current	-	100	-	μA	V _{OUT} ≥ V _{BC} - 0.2V
V _{BL}	Voltage battery low	2.3	-	2.5	V	BCP input only
V _{BF}	Voltage battery fail	2.0	-	2.2	V	BCP input only

Note: Typical values indicate operation at $T_A = 25^\circ\text{C}$, $V_{CC} = 5V$ or V_{BC} .

Capacitance ($T_A = 25^\circ\text{C}$, $F = 1\text{MHz}$, $V_{CC} = 5.0V$)

Symbol	Parameter	Minimum	Typical	Maximum	Unit	Conditions
C _{IN}	Input capacitance	-	-	8	pF	Input voltage = 0V
C _{OUT}	Output capacitance	-	-	10	pF	Output voltage = 0V

Note: This parameter is sampled and not 100% tested.

bq2203A

AC Test Conditions

Parameter	Test Conditions
Input pulse levels	0V to 3.0V
Input rise and fall times	5ns
Input and output timing reference levels	1.5V (unless otherwise specified)
Output load (including scope and jig)	See Figure 3

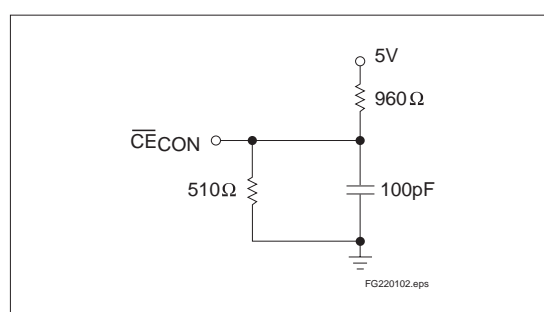

Figure 3. Output Load

Power-Fail Control ($T_A = T_{OPR}$)

Symbol	Parameter	Min.	Typ.	Max.	Unit	Conditions
t _{PF}	V _{CC} slew 4.75 to 4.25 V	300	-	-	μs	
t _{FS}	V _{CC} slew 4.25 V to V _{SO}	10	-	-	μs	
t _{PU}	V _{CC} slew 4.25 to 4.75 V	0	-	-	μs	
t _{CED}	Chip-enable propagation delay		7	10	ns	
t _{CER}	Chip-enable recovery time	40	80	120	ms	Time during which SRAM is write-protected after V _{CC} passes V _{PF_D} on power-up
t _{RR}	V _{PF_D} to \overline{RST} inactive	t _{CER}	-	t _{CER}	ms	Time, after V _{CC} becomes valid, before \overline{RST} is cleared
t _{AS}	Input A set up to \overline{CE}	0	-	-	ns	
t _{WPT}	Write-protect time	40	100	150	μs	Delay after V _{CC} slews down past V _{PF_D} before SRAM is write-protected
t _R	V _{PF_D} to \overline{RST} active	t _{WPT}	-	t _{WPT}	μs	Delay after V _{CC} slews down past V _{PF_D} before \overline{RST} is active
t _{BC}	V _{PF_D} to $\overline{BCL/BCF}$ active	t _{CER}	-	t _{CER}	ms	Delay after V _{CC} slews up past V _{PF_D} before \overline{BCL} or \overline{BCF} is active

Note: Typical values indicate operation at $T_A = 25^\circ\text{C}$, $V_{CC} = 5\text{V}$.

Caution: Negative undershoots below the absolute maximum rating of -0.3V in battery-backup mode may affect data integrity.

Nov. 1994 B

Power-Down Timing

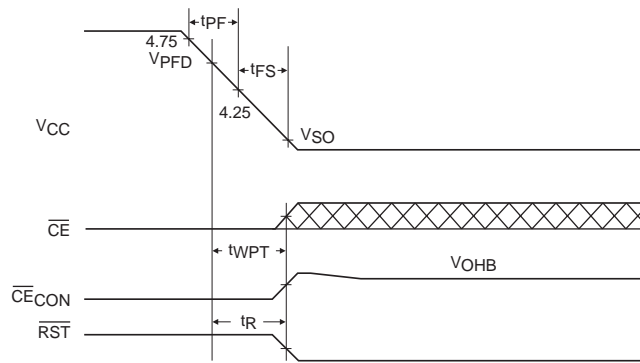

TD220202.eps

Power-Up Timing

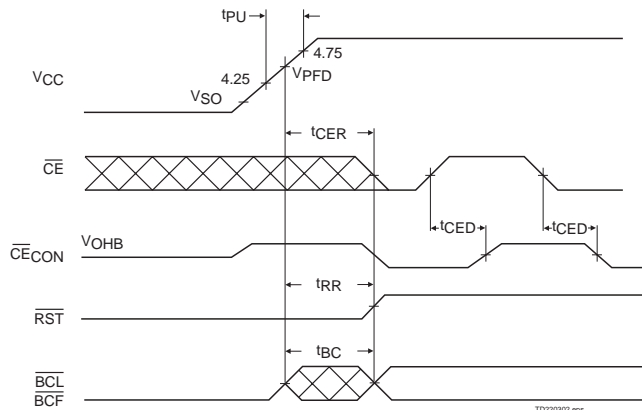

TD220302.eps

Address-Decode Timing

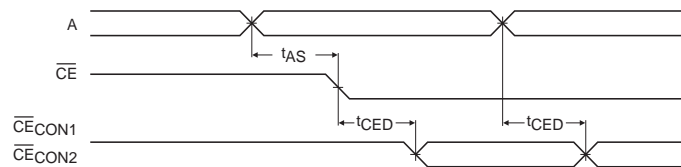

TD220204.eps

bq2203A

16-Pin SOIC Narrow

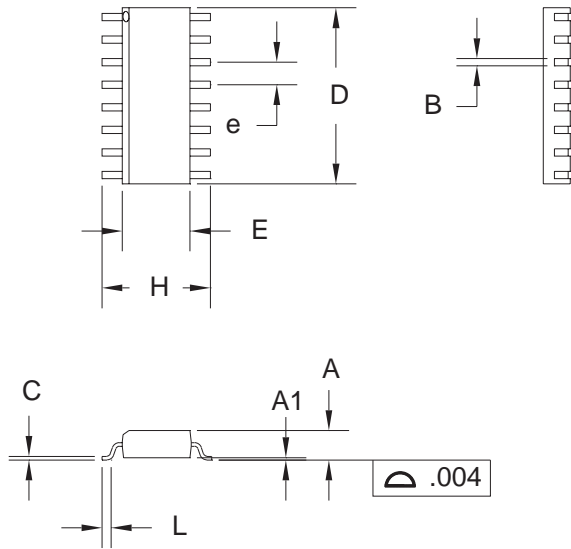

16-Pin SN (SOIC Narrow)

Dimension	Minimum	Maximum
A	0.060	0.070
A1	0.004	0.010
B	0.013	0.020
C	0.007	0.010
D	0.385	0.400
E	0.150	0.160
e	0.045	0.055
H	0.225	0.245
L	0.015	0.035

All dimensions are in inches.

16-Pin DIPNarrow

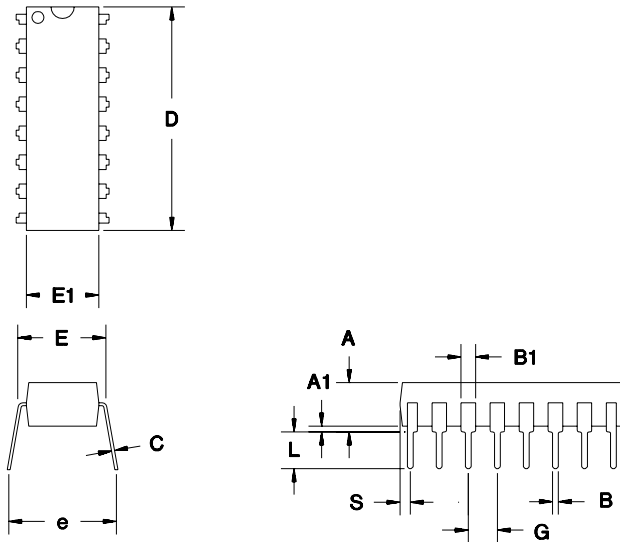

16-Pin PN (DIP Narrow)

Dimension	Minimum	Maximum
A	0.160	0.180
A1	0.015	0.040
B	0.015	0.022
B1	0.055	0.065
C	0.008	0.013
D	0.740	0.770
E	0.300	0.325
E1	0.230	0.280
e	0.300	0.370
G	0.090	0.110
L	0.115	0.150
S	0.020	0.040

All dimensions are in inches.

bq2203A

Data Sheet Revision History

Change No.	Page No.	Description	Nature of Change
1	-	Changed data sheet from "Preliminary" to "Final"	
1	5	Changed maximum charge output internal resistance (R _{BCS})	Was: 1500Ω Is: 1750Ω

Note: Change 1 = Nov. 1994 B changes from Dec. 1992 A.

Ordering Information

bq2203A

Temperature Range:

blank = Commercial (0 to +70°C)
N = Industrial (-40 to +85°C)*

Package Option:

PN = 16-pin plastic DIP Narrow
SN = 16-pin SOIC Narrow

Device:

bq2203A SRAM Nonvolatile Controller
With Battery Monitor and Reset

*Contact factory for availability.

IMPORTANT NOTICE

Texas Instruments and its subsidiaries (TI) reserve the right to make changes to their products or to discontinue any product or service without notice, and advise customers to obtain the latest version of relevant information to verify, before placing orders, that information being relied on is current and complete. All products are sold subject to the terms and conditions of sale supplied at the time of order acknowledgement, including those pertaining to warranty, patent infringement, and limitation of liability.

TI warrants performance of its semiconductor products to the specifications applicable at the time of sale in accordance with TI's standard warranty. Testing and other quality control techniques are utilized to the extent TI deems necessary to support this warranty. Specific testing of all parameters of each device is not necessarily performed, except those mandated by government requirements.

CERTAIN APPLICATIONS USING SEMICONDUCTOR PRODUCTS MAY INVOLVE POTENTIAL RISKS OF DEATH, PERSONAL INJURY, OR SEVERE PROPERTY OR ENVIRONMENTAL DAMAGE ("CRITICAL APPLICATIONS"). TI SEMICONDUCTOR PRODUCTS ARE NOT DESIGNED, AUTHORIZED, OR WARRANTED TO BE SUITABLE FOR USE IN LIFE-SUPPORT DEVICES OR SYSTEMS OR OTHER CRITICAL APPLICATIONS. INCLUSION OF TI PRODUCTS IN SUCH APPLICATIONS IS UNDERSTOOD TO BE FULLY AT THE CUSTOMER'S RISK.

In order to minimize risks associated with the customer's applications, adequate design and operating safeguards must be provided by the customer to minimize inherent or procedural hazards.

TI assumes no liability for applications assistance or customer product design. TI does not warrant or represent that any license, either express or implied, is granted under any patent right, copyright, mask work right, or other intellectual property right of TI covering or relating to any combination, machine, or process in which such semiconductor products or services might be or are used. TI's publication of information regarding any third party's products or services does not constitute TI's approval, warranty or endorsement thereof.