

TPS60120, TPS60121, TPS60122, TPS60123 REGULATED 3.3 V, 200-mA HIGH EFFICIENCY CHARGE PUMP DC/DC CONVERTERS

SLVS257A – NOVEMBER 1999 – REVISED DECEMBER 1999

features

- High Average Efficiency Over Input Voltage Range Because of Special Switching Topology
- Up to 200-mA Output Current (TPS60120 and TPS60121) From an Input Voltage Range of 1.8-V to 3.6-V
- No Inductors Required, Low EMI
- Regulated 3.3-V \pm 4% Output
- Only Four External Components Required
- 55- μ A Quiescent Supply Current
- 0.05- μ A Shutdown Current
- Load Disconnected in Shutdown
- Space-saving, Thermally-Enhanced PowerPAD™ Package
- Evaluation Module Available (TPS60120EVM-142)

description

The TPS6012x step-up, regulated charge pumps generate a 3.3-V \pm 4% output voltage from a 1.8-V to 3.6-V input voltage (two alkaline, NiCd, or NiMH batteries). The output current is 200 mA for the TPS60120/TPS60121 and 100 mA for the TPS60122/TPS60123, all from a 2-V input. Four external capacitors are needed to build a complete high efficiency dc/dc charge pump converter. To achieve the high efficiency over a wide input voltage range, the charge pump automatically selects between a 1.5x or doubler conversion mode. From a 2-V input, all ICs can start with full load current.

The devices feature the power-saving pulse-skip mode to extend battery life at light loads. TPS60120 and TPS60122 include a low battery comparator. TPS60121 and TPS60123 feature a power-good output. The logic shutdown function reduces the supply current to a maximum of 1 μ A and disconnects the load from the input. Special current-control circuitry prevents excessive current from being drawn from the battery during start-up. This dc/dc converter requires no inductors, therefore EMI is of low concern. It is available in the small, thermally enhanced 20-pin PowerPAD™ package (PWP).

applications

- Battery-Powered Applications
- Two Battery Cells to 3.3-V Conversion
- Portable Instruments
- Battery-Powered Microprocessor Systems
- Miniature Equipment
- Backup-Battery Boost Converters
- PDA's, Organizers, Laptops
- MP-3 Portable Audio Players
- Handheld Instrumentation
- Medical Instruments (e.g., Glucose Meters)
- Cordless Phones

efficiency (TPS60120, TPS60121)

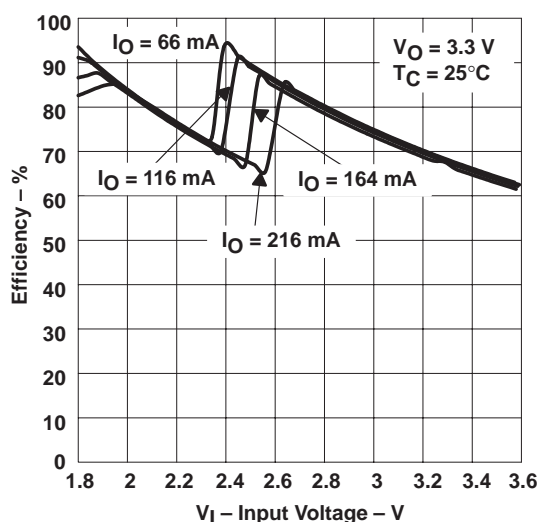

typical operating circuit

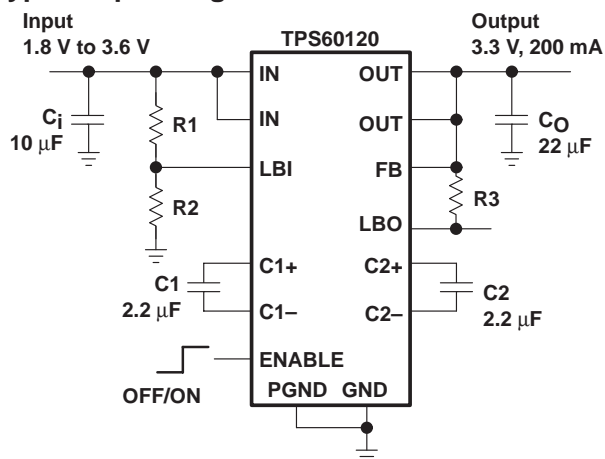

Please be aware that an important notice concerning availability, standard warranty, and use in critical applications of Texas Instruments semiconductor products and disclaimers thereto appears at the end of this data sheet.

PowerPAD is a trademark of Texas Instruments Incorporated.

PRODUCTION DATA information is current as of publication date. Products conform to specifications per the terms of Texas Instruments standard warranty. Production processing does not necessarily include testing of all parameters.

**TEXAS
INSTRUMENTS**

POST OFFICE BOX 655303 • DALLAS, TEXAS 75265

Copyright © 1999, Texas Instruments Incorporated

TPS60120, TPS60121, TPS60122, TPS60123 REGULATED 3.3 V, 200-mA HIGH EFFICIENCY CHARGE PUMP DC/DC CONVERTERS

SLVS257A – NOVEMBER 1999 – REVISED DECEMBER 1999

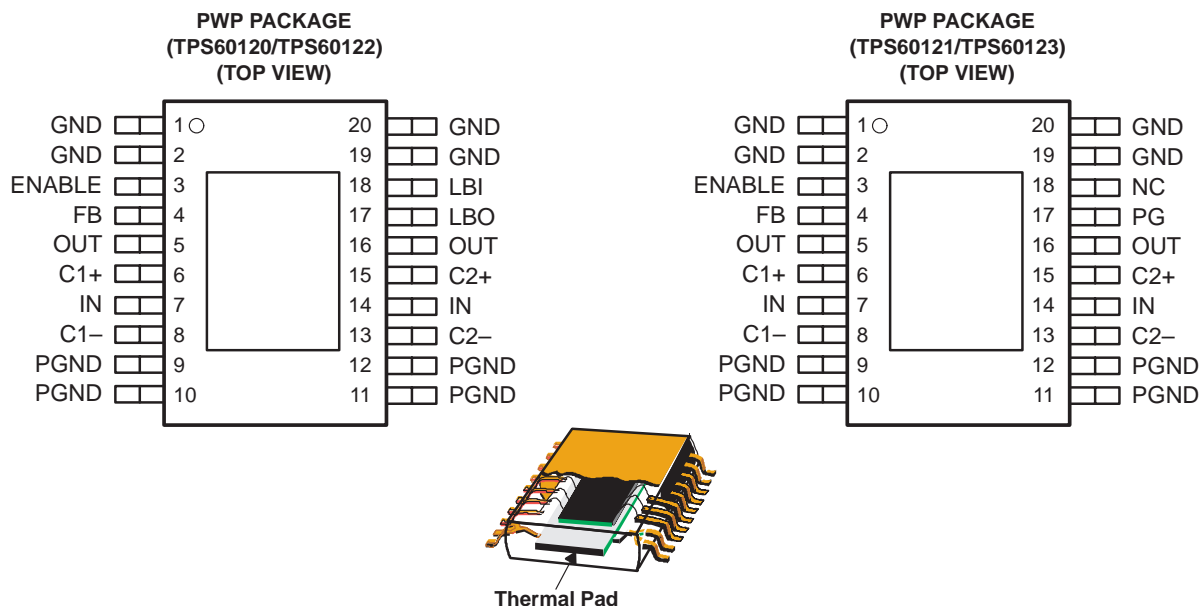

AVAILABLE OPTIONS

T _A	PART NUMBER†	PACKAGE	DEVICE FEATURES
-40°C to 85°C	TPS60120PWP	PWP 20-Pin thermally enhanced TSSOP	2-Cell to 3.3 V, 200 mA
	TPS60121PWP		Low battery detector
	TPS60122PWP		Power good detector
	TPS60123PWP		2-Cell to 3.3 V, 100 mA
			Low battery detector
			Power good detector

† The PWP package is available taped and reeled. Add R suffix to device type (e.g. TPS60120PWPR) to order quantities of 2000 devices per reel.

TPS60120, TPS60121, TPS60122, TPS60123 REGULATED 3.3 V, 200-mA HIGH EFFICIENCY CHARGE PUMP DC/DC CONVERTERS

SLVS257A – NOVEMBER 1999 – REVISED DECEMBER 1999

functional block diagram

TPS60120/TPS60122

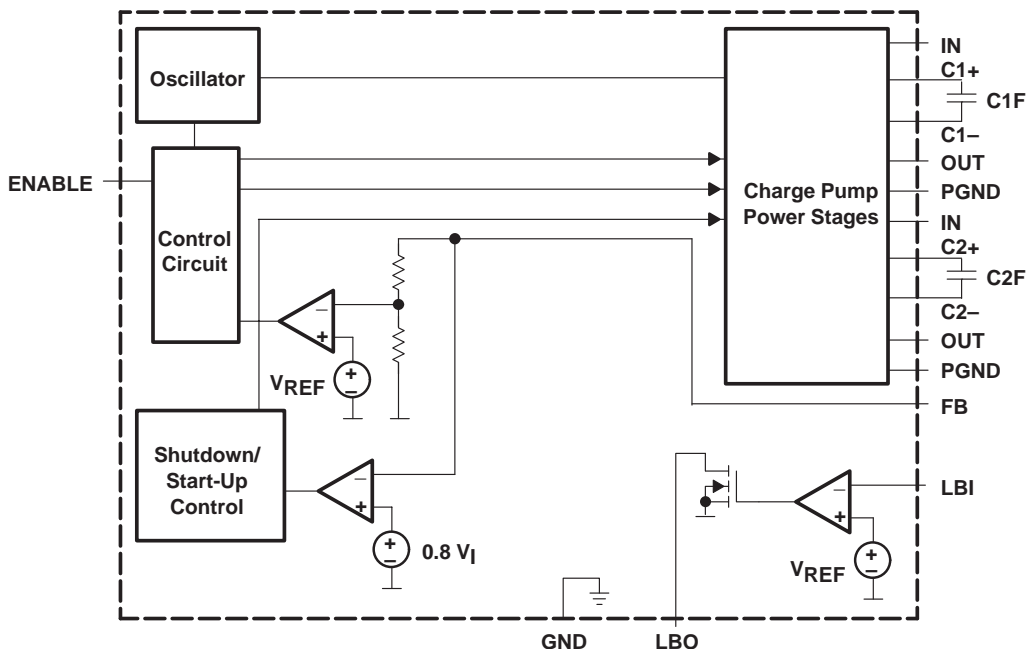

TPS60121/TPS60123

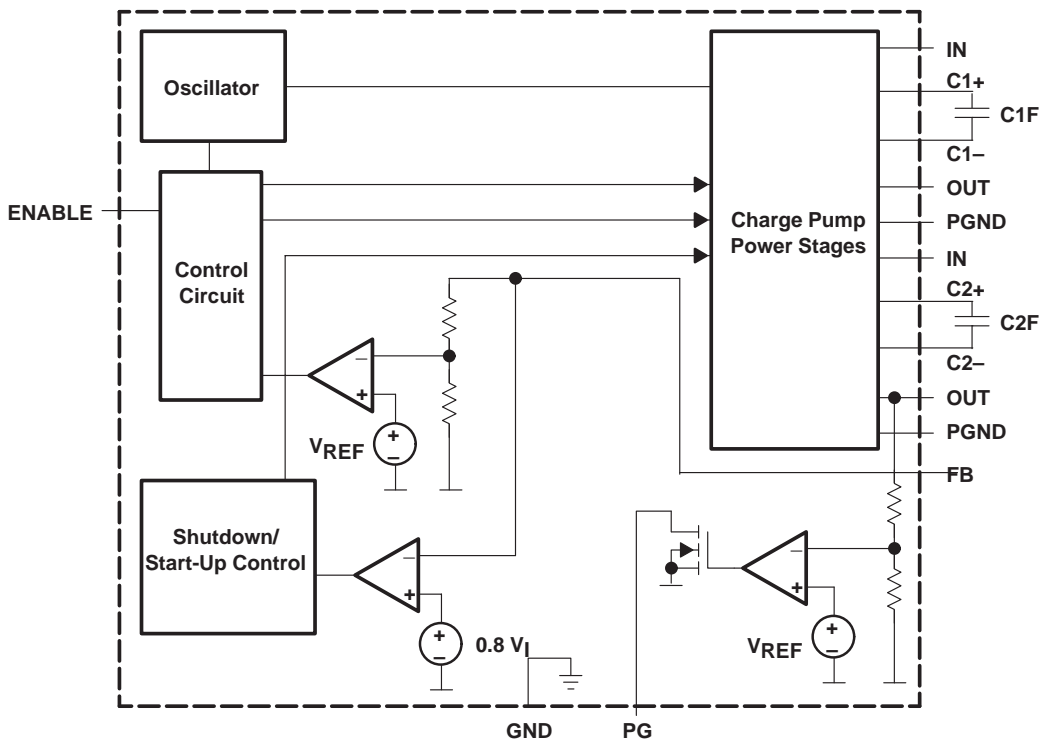

TPS60120, TPS60121, TPS60122, TPS60123 REGULATED 3.3 V, 200-mA HIGH EFFICIENCY CHARGE PUMP DC/DC CONVERTERS

SLVS257A – NOVEMBER 1999 – REVISED DECEMBER 1999

Terminal Functions

TERMINAL NAME	NO.	I/O	DESCRIPTION
C1+	6		Positive terminal of the flying capacitor C1
C1–	8		Negative terminal of the flying capacitor C1
C2+	15		Positive terminal of the flying capacitor C2
C2–	13		Negative terminal of the flying capacitor C2
ENABLE	3	I	ENABLE input. Connect ENABLE to IN for normal operation. When ENABLE is a logic low, the device turns off and the supply current decreases to 0.05 μ A. The output is disconnected from the input when the device is placed in shutdown.
FB	4	I	Feedback input. Connect FB to OUT as close to the load as possible to achieve best regulation. Resistive divider is on the chip to match the internal reference voltage of 1.21 V.
GND	1, 2, 19, 20		Ground. Analog ground for internal reference and control circuitry. Connect to PGND through a short trace.
IN	7, 14	I	Supply input. Connect to an input supply in the 1.8-V to 3.6-V range. Bypass IN to PGND with a ($C_O/2$) μ F capacitor. Connect both IN through a short trace.
LBO/PG	17	O	Low battery detector output or power good output. Open drain output of the low battery or power-good comparator. It can sink 1 mA. A 100-k Ω to 1-M Ω pullup is recommended. Leave terminal unconnected if not used.
LBI/NC	18	I	Low battery detector input (TPS60120/TPS60122 only). The input is compared to the internal 1.21-V reference voltage. Connect terminal to ground if the low-battery detector function is not used. On the TPS60121 and TPS60123, this terminal is not connected.
OUT	5, 16	O	Regulated 3.3-V power output. Connect both OUT terminals through a short trace and bypass OUT to GND with the output filter capacitor C_O .
PGND	9–12		Power ground. Charge-pump current flows through this pin. Connect all PGND pins together.

detailed description

operating principle

The TPS6012x charge pumps provide a regulated 3.3-V output from a 1.8-V to 3.6-V input. They deliver a maximum load current of 200 mA or 100 mA, respectively. Designed specifically for space-critical, battery-powered applications, the complete charge pump circuit requires only four external capacitors. The circuit is optimized for efficiency over a wide input voltage range.

The TPS6012x charge pumps consist of an oscillator, a 1.21-V bandgap reference, an internal resistive feedback circuit, an error amplifier, high current MOSFET switches, a shutdown/start-up circuit, a low-battery or power-good comparator, and a control circuit (see the functional block diagram).

The device consists of two single-ended charge pumps. The power stages of the charge pump are automatically configured to amplify the input voltage with a conversion factor of 1.5 or 2. The conversion ratio depends on input voltage and output current. With input voltages lower than approximately 2.4 V, the converter will run in a voltage doubler mode with a gain of two. With a higher input voltage, the converter operates with a gain of 1.5 V. This assures high efficiency over the wide input voltage range of a two-cell battery stack and is further described in the *adaptive mode switching* section.

adaptive mode switching

The ON-resistance of the MOSFETs that are in the charge path of the flying capacitors is regulated when the charge pump operates in voltage doubler-mode. It is changed depending on the output voltage that is fed back into the control loop. This way, the time-constant during the charging phase can be modified and increased versus a time-constant for fully switched-on MOSFETs. The ON-resistance of both switches and the capacitance of the flying capacitor define the time constant. The MOSFET switches in the discharge path of the charge pump are always fully switched on to their minimum $r_{DS(on)}$. With the time-constant during charge phase being larger than the time constant in discharge phase, the voltage on the flying capacitors stabilizes to the lowest possible value necessary to get a stable V_O .



POST OFFICE BOX 655303 • DALLAS, TEXAS 75265

TPS60120, TPS60121, TPS60122, TPS60123 REGULATED 3.3 V, 200-mA HIGH EFFICIENCY CHARGE PUMP DC/DC CONVERTERS

SLVS257A – NOVEMBER 1999 – REVISED DECEMBER 1999

adaptive mode switching (continued)

The voltage on the flying capacitors is measured and compared with the supply voltage V_I . If the voltage across the flying capacitors is smaller than half of the supply voltage, then the charge pump switches into the 1.5x conversion-mode. The charge pump switches back from a 1.5x conversion-mode to a voltage doubler mode if the load current in 1.5x conversion-mode can no more be delivered.

With this control mode the device runs in doubler-mode at low V_I and in 1.5x conversion-mode at high V_I to optimize the efficiency. The most desirable doubler mode is automatically selected depending on both V_I and I_L . This means that at light loads the device selects the 1.5x conversion-mode already at smaller supply voltages than at heavy loads.

The TPS60120 output voltage is regulated using the *ACTIVE-CYCLE* regulation. An active cycle controlled Charge pump utilizes two methods to control the output voltage. At high load currents it varies the on resistances of the internal switches and keeps the ratio ON/OFF time (=frequency) constant. That means the charge pump runs at a fixed frequency. It also keeps the output voltage ripple as low as in linear-mode. At light loads the internal resistance and also the amount of energy transferred per pulse is fixed and the charge pump regulates the voltage by means of a variable ratio of ON-to-OFF time. In this operating point, it runs like a skip mode controlled charge pump with a very high internal resistance, which also enables a low ripple in this operation mode. Since the charge pump does effectively switch at lower frequencies at light loads, it achieves a low quiescent current.

pulse-skip mode

In pulse-skip mode the error amplifier disables switching of the power stages when it detects an output higher than 3.3 V. The oscillator halts and the IC then skips switching cycles until the output voltage drops below 3.3 V. Then the error amplifier reactivates the oscillator and starts switching the power stages again. The pulse-skip regulation mode minimizes operating current because it does not switch continuously and deactivates all functions except bandgap reference, error amplifier, and low-battery/power-good comparator when the output is higher than 3.3 V. When switching is disabled from the error amplifier, the load is also isolated from the input. In pulse-skip mode, a special current control circuitry limits the peak current. This assures moderate output voltage ripple and also prevents the device from drawing excessive current spikes out of the battery.

start-up procedure

During start-up, i.e., when ENABLE is set from logic low to logic high, the output capacitor is charged up with a limited current until the output voltage V_O reaches $0.8 \times V_I$. When the start-up comparator detects this voltage limit, the IC begins switching. This start-up charging of the output capacitor ensures a short start-up time and eliminates the need of a Schottky diode between IN and OUT. The IC starts with a maximum load, which is defined by a 16- Ω resistor or 33- Ω resistor, respectively.

shutdown

Driving ENABLE low places the device in shutdown mode. This disables all switches, the oscillator, and control logic. The device typically draws 0.05 μA (1 μA max) of supply current in this mode. Leakage current drawn from the output is as low as 1 μA max. The device exits shutdown once ENABLE is set to a high level. The typical no-load shutdown exit time is 10 μs . When the device is in shutdown, the load is isolated from the input.

undervoltage lockout

The TPS6012x devices have an undervoltage lockout feature that deactivates the device and places it in shutdown mode when the input voltage falls below 1.6 V.

low-battery detector (TPS60120 and TPS60122)

The internal low-battery comparator trips at $1.21 \text{ V} \pm 5\%$ when the voltage on LBI ramps down. The battery voltage at which the comparator initiates a low battery warning at the LBO output can easily be programmed with a resistive divider as shown in Figure 1. The sum of resistors R1 and R2 is recommended to be in the 100 k Ω to 1 M Ω range.



TPS60120, TPS60121, TPS60122, TPS60123 REGULATED 3.3 V, 200-mA HIGH EFFICIENCY CHARGE PUMP DC/DC CONVERTERS

SLVS257A – NOVEMBER 1999 – REVISED DECEMBER 1999

low-battery detector (TPS60120 and TPS60122) (continued)

LBO is an open drain output. An external pullup resistor to OUT, in the 100 kΩ to 1 MΩ range, is recommended. During start-up, the LBO output signal is invalid for the first 500 μs. LBO is high impedance when the device is disabled.

If the low-battery comparator function is not used, connect LBI to ground and leave LBO unconnected.

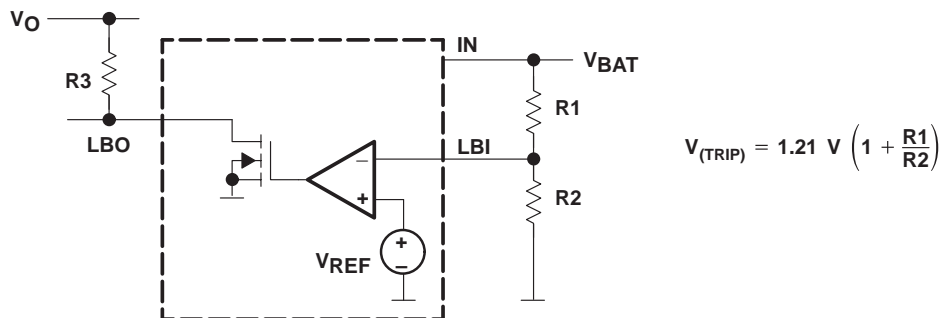

Figure 1. Programming of the Low-Battery Comparator Trip Voltage

Formulas to calculate the resistive divider for low battery detection, with $V_{LBI} = 1.15\text{ V} - 1.27\text{ V}$:

$$R2 = 1\text{ M}\Omega \times \frac{V_{LBI}}{V_{Bat}}$$

$$R1 = 1\text{ M}\Omega - R2$$

Formulas to calculate the minimum and maximum battery voltage that triggers the low battery detector:

$$V_{Bat(min)} = V_{LBI(min)} \times \frac{R1_{(min)} + R2_{(max)}}{R2_{(max)}}$$

$$V_{Bat(max)} = V_{LBI(max)} \times \frac{R1_{(max)} + R2_{(min)}}{R2_{(min)}}$$

Table 1. Recommended Values for the Resistive Divider From the E96 Series ($\pm 1\%$), $V_{LBI} = 1.15\text{ V} - 1.27\text{ V}$

V_{BAT}/V	$R1/k\Omega$	$R2/k\Omega$	$V_{BAT (MIN)}/V$		$V_{BAT(MAX)}/V$	
1.8	357	732	1.700	-5.66%	1.902	5.67%
1.9	365	634	1.799	-5.32%	2.016	6.11%
2.0	412	634	1.883	-5.86%	2.112	5.6%
2.1	432	590	1.975	-5.95%	2.219	5.67%
2.2	442	536	2.080	-5.45%	2.338	6.27%

Using $\pm 1\%$ accurate resistors, the total accuracy of the trip voltage is about $\pm 6\%$, considering the $\pm 4\%$ accuracy the integrated voltage reference adds and considering that not every calculated resistor value is available.

A 100 nF bypass capacitor should be connected in parallel to R2 if large line transients are expected. These voltage drops can inadvertently trigger the low-battery comparator and produce a wrong low-battery warning signal at the LBO terminal.

TPS60120, TPS60121, TPS60122, TPS60123 REGULATED 3.3 V, 200-mA HIGH EFFICIENCY CHARGE PUMP DC/DC CONVERTERS

SLVS257A – NOVEMBER 1999 – REVISED DECEMBER 1999

power-good detector (TPS60121 and TPS60123)

The PG terminal is an open-drain output that is pulled low when the output is out of regulation. When the output voltage rises to about 90% of its nominal voltage, the power-good output is released. PG is high impedance when the device is disabled. A pullup resistor must be connected between PG and OUT. The pullup resistor should be in the 100 kΩ to 1 MΩ range. If the power-good function is not used, then PG should remain unconnected.

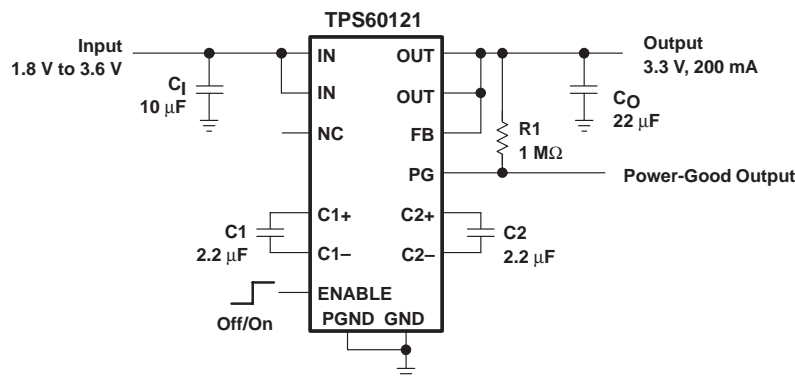

Figure 2. Typical Operating Circuit Using Power-Good Comparator

absolute maximum ratings (see Note 1)†

Input voltage range, V_I (IN, OUT, ENABLE, FB, LBI, LBO/PG)	-0.3 V to 5.5 V
Differential input voltage, V_{ID} (C1+, C2+ to GND)	-0.3 V to ($V_O + 0.3$ V)
Differential input voltage, V_{ID} (C1-, C2- to GND)	-0.3 V to ($V_I + 0.3$ V)
Continuous total power dissipation	See dissipation rating table
Continuous output current TPS60120, TPS60121	300 mA
Continuous output current TPS60122, TPS60123	150 mA
Storage temperature range, T_{stg}	-55°C to 150°C
Lead temperature 1,6 mm (1/16 inch) from case for 10s	260°C
Maximum junction temperature, T_J	150°C

† Stresses beyond those listed under "absolute maximum ratings" may cause permanent damage to the device. These are stress ratings only, and functional operation of the device at these or any other conditions beyond those indicated under "recommended operating conditions" is not implied. Exposure to absolute-maximum-rated conditions for extended periods may affect device reliability.

NOTE 1: $V(ENABLE)$, $V(LBI)$ and $V(LBO/PG)$ can exceed V_I up to the maximum rated voltage without increasing the leakage current drawn by these inputs.

DISSIPATION RATING TABLE 1 FREE-AIR TEMPERATURE (see Figure 3)

PACKAGE	$T_A \leq 25^\circ\text{C}$ POWER RATING	DERATING FACTOR ABOVE $T_A = 25^\circ\text{C}$	$T_A = 70^\circ\text{C}$ POWER RATING	$T_A = 85^\circ\text{C}$ POWER RATING
PWP	700 mW	5.6 mW/°C	448 mW	364 mW

DISSIPATION RATING TABLE 2 FREE-AIR TEMPERATURE (see Figure 4)

PACKAGE	$T_C \leq 62.5^\circ\text{C}$ POWER RATING	DERATING FACTOR ABOVE $T_C = 62.5^\circ\text{C}$	$T_C = 70^\circ\text{C}$ POWER RATING	$T_C = 85^\circ\text{C}$ POWER RATING
PWP	25 mW	285.7 mW/°C	22.9 mW	18.5 mW



TPS60120, TPS60121, TPS60122, TPS60123
REGULATED 3.3 V, 200-mA HIGH EFFICIENCY CHARGE PUMP
DC/DC CONVERTERS

SLVS257A – NOVEMBER 1999 – REVISED DECEMBER 1999

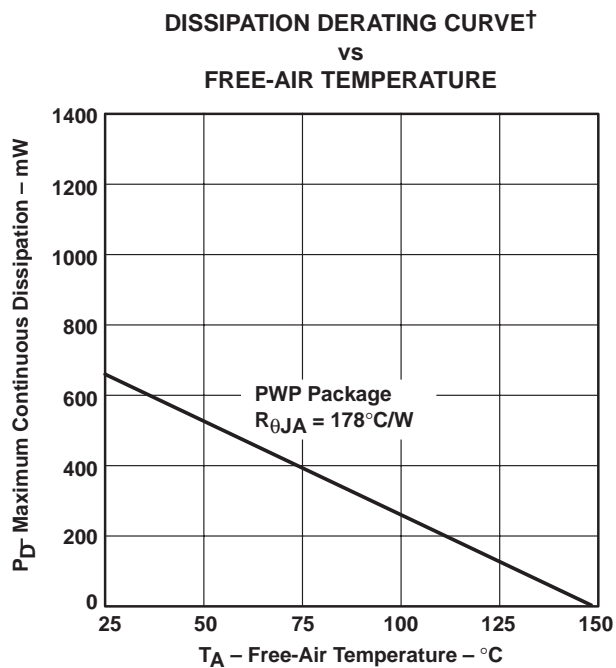

Figure 3

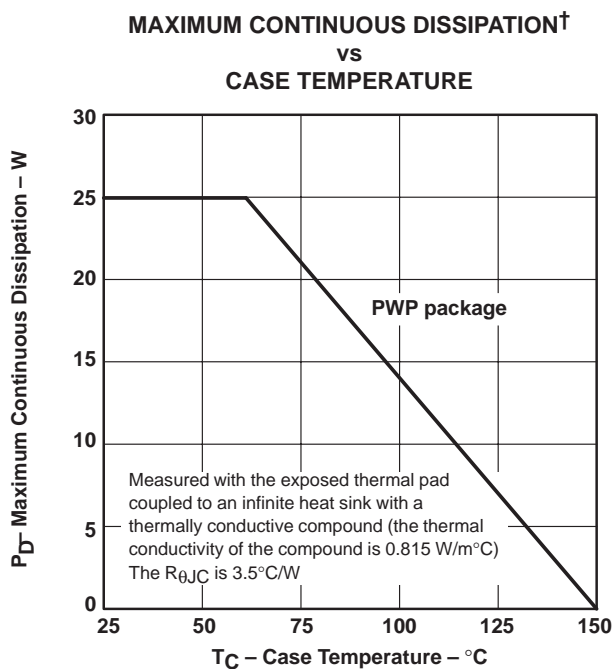

Figure 4

† Dissipation rating tables and figures are provided for maintenance of junction temperature at or below absolute maximum temperature of 150°C. It is recommended not to exceed a junction temperature of 125°C.

recommended operating conditions

		MIN	MAX	UNIT
Input voltage, V _I		1.8	3.6	V
Output current, I _O	TPS60120 and TPS60121		200	mA
	TPS60122 and TPS60123		100	
Operating junction temperature, T _J			125	°C

TPS60120, TPS60121, TPS60122, TPS60123
REGULATED 3.3 V, 200-mA HIGH EFFICIENCY CHARGE PUMP
DC/DC CONVERTERS

SLVS257A – NOVEMBER 1999 – REVISED DECEMBER 1999

electrical characteristics at $C_1 = 10 \mu\text{F}$, $C_{1F} = C_{2F} = 2.2 \mu\text{F}$, $C_O = 22 \mu\text{F}$, $T_C = -40^\circ\text{C}$ to 85°C , $V_I = 2 \text{ V}$, $V_{FB} = V_O$ and $V_{(\text{ENABLE})} = V_I$ (unless otherwise noted)

PARAMETER		TEST CONDITIONS	MIN	TYP	MAX	UNIT
V_I	Input voltage		1.8		3.6	V
$V_{(\text{UVLO})}$	Input undervoltage lockout threshold	$T_C = 25^\circ\text{C}$		1.6	1.8	V
$I_{O(\text{MAX})}$	Maximum output current	TPS60120/TPS60121	200			mA
		TPS60122/TPS60123	100			mA
V_O	Output voltage	$1.8 \text{ V} < V_I < 2 \text{ V}$, $0 < I_O < I_{O(\text{MAX})}/2$ $T_C = 0^\circ\text{C}$ to 70°C	3.17		3.43	V
		$2 \text{ V} < V_I < 3.3 \text{ V}$, $0 < I_O < I_{O(\text{MAX})}$	3.17		3.43	
		$3.3 \text{ V} < V_I < 3.6 \text{ V}$, $0 < I_O < I_{O(\text{MAX})}$	3.17		3.47	
$I_{\text{lkg}(\text{OUT})}$	Output leakage current	$V_I = 2.4 \text{ V}$, $V_{(\text{ENABLE})} = 0 \text{ V}$			1	μA
I_Q	Quiescent current (no-load input current)	$V_I = 2.4 \text{ V}$		55	90	μA
$I_{Q(\text{SDN})}$	Shutdown supply current	$V_I = 2.4 \text{ V}$, $V_{(\text{ENABLE})} = 0 \text{ V}$		0.05	1	μA
$f_{\text{OSC}(\text{INT})}$	Internal switching frequency	$V_I = 2.4 \text{ V}$	210	320	450	kHz
V_{IL}	Enable input voltage low	$V_I = 1.8 \text{ V}$			$0.3 \times V_I$	V
V_{IH}	Enable input voltage high	$V_I = 3.6 \text{ V}$	$0.7 \times V_I$			V
$I_{\text{lkg}(\text{ENABLE})}$	Enable input leakage current	$V_{(\text{ENABLE})} = V_{\text{GND}}$ or V_I		0.01	0.1	μA
	Output load regulation	$V_I = 2.4 \text{ V}$, $1 \text{ mA} < I_O < I_{O(\text{MAX})}$ $T_C = 25^\circ\text{C}$		0.003%		/mA
	Output line regulation	$2 \text{ V} < V_I < 3.3 \text{ V}$, $I_O = 100 \text{ mA}$, $T_C = 25^\circ\text{C}$		0.3%		/V
	Short circuit current limit	$V_I < 2.4 \text{ V}$, $V_O = 0 \text{ V}$, $T_C = 25^\circ\text{C}$		115		mA
$V_{(\text{LBTRIP})}$	Low battery trip voltage	TPS60120/TPS60122 $V_I = 1.8 \text{ V}$ to 2.2 V , Hysteresis 0.8% for rising LBI, $T_C = 0^\circ\text{C}$ to 70°C	1.15	1.21	1.27	V
$I_{\text{I}(\text{LBI})}$	LBI input current	TPS60120/TPS60122 $V_{(\text{LBI})} = 1.3 \text{ V}$			100	nA
$V_{O(\text{LBO})}$	LBO output voltage low (see Note 2)	TPS60120/TPS60122 $V_{(\text{LBI})} = 0 \text{ V}$, $I_{(\text{LBO,SINK})} = 1 \text{ mA}$			0.4	V
$I_{\text{lkg}(\text{LBO})}$	LBO leakage current	TPS60120/TPS60122 $V_{(\text{LBI})} = 1.3 \text{ V}$, $V_{(\text{LBO})} = 3.3 \text{ V}$		0.01	0.1	μA
$V_{(\text{PGTRIP})}$	Power-good trip voltage	TPS60121/TPS60123 $T_C = 0^\circ\text{C}$ to 70°C	$0.86 \times V_O$	$0.90 \times V_O$	$0.94 \times V_O$	V
$V_{\text{hys}(\text{PG})}$	Power-good trip voltage hysteresis	TPS60121/TPS60123 V_O ramping negative, $T_{\text{CA}} = 0^\circ\text{C}$ to 70°C		0.8%		
$V_{O(\text{PG})}$	Power-good output voltage low (see Note 2)	TPS60121/TPS60123 $V_O = 0 \text{ V}$, $I_{(\text{PG,SINK})} = 1 \text{ mA}$			0.4	V
$I_{\text{lkg}(\text{PG})}$	Power-good leakage current	TPS60121/TPS60123 $V_O = 3.3 \text{ V}$, $V_{(\text{PG})} = 3.3 \text{ V}$		0.01	0.1	μA

NOTE 2: During start-up the LBO and PG output signal is invalid for the first 500 μs .



TPS60120, TPS60121, TPS60122, TPS60123
REGULATED 3.3 V, 200-mA HIGH EFFICIENCY CHARGE PUMP
DC/DC CONVERTERS

SLVS257A – NOVEMBER 1999 – REVISED DECEMBER 1999

PARAMETER MEASUREMENT INFORMATION

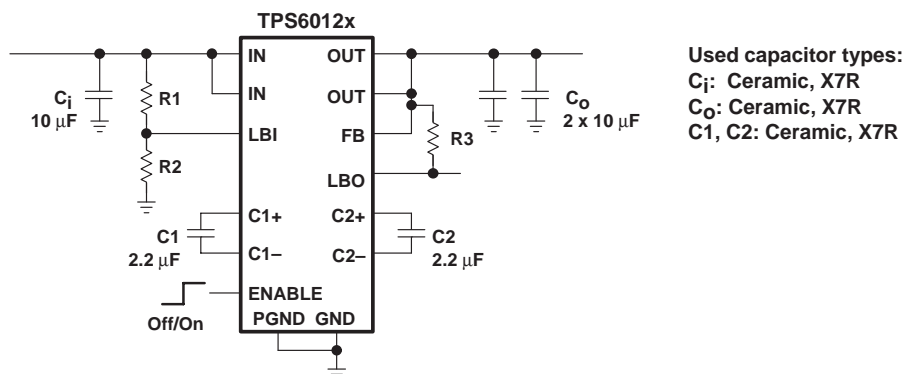

Figure 5. Circuit Used For Typical Characteristics Measurements

TYPICAL CHARACTERISTICS

Table of Graphs

			FIGURE
η	Efficiency	vs Output Current (TPS60120 and TPS60122)	6, 7
		vs Input Voltage (TPS60120 and TPS60122)	8, 9
I	Supply Current	vs Input Voltage	10
V_O	Output Voltage	vs Output Current (TPS60120 and TPS60122)	11, 12
V_O	Output Voltage	vs Input Voltage (TPS60120 and TPS60122)	13, 14
V_O	Output Voltage Ripple	vs Time	15 – 17
V_{PP}	Output Voltage Ripple Amplitude	vs Input Voltage	18
$f_{(OSC)}$	Oscillator Frequency	vs Input Voltage	19
	Load Transient Response		20
	Line Transient Response		21
V_O	Output Voltage	vs Time (Start-Up Timing)	22

TPS60120, TPS60121, TPS60122, TPS60123 REGULATED 3.3 V, 200-mA HIGH EFFICIENCY CHARGE PUMP DC/DC CONVERTERS

SLVS257A – NOVEMBER 1999 – REVISED DECEMBER 1999

TYPICAL CHARACTERISTICS

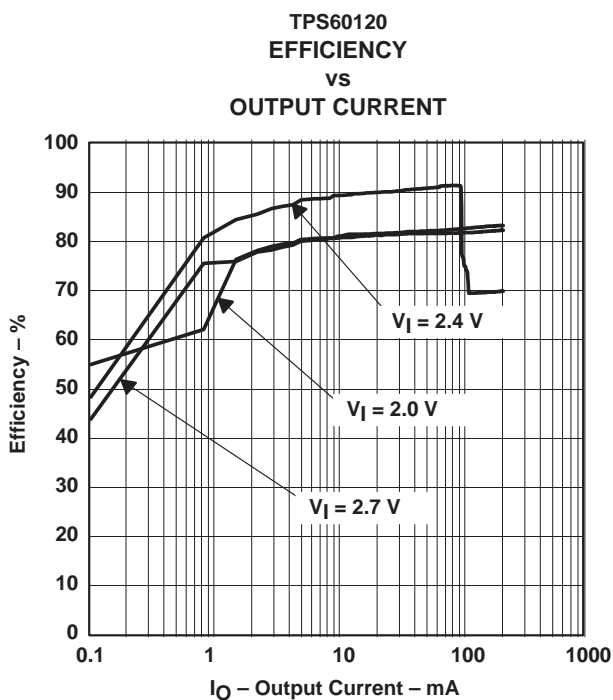

Figure 6

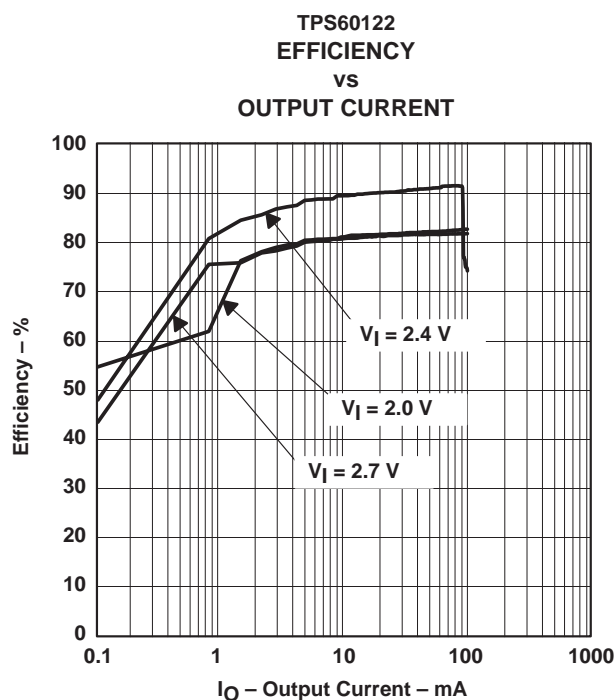

Figure 7

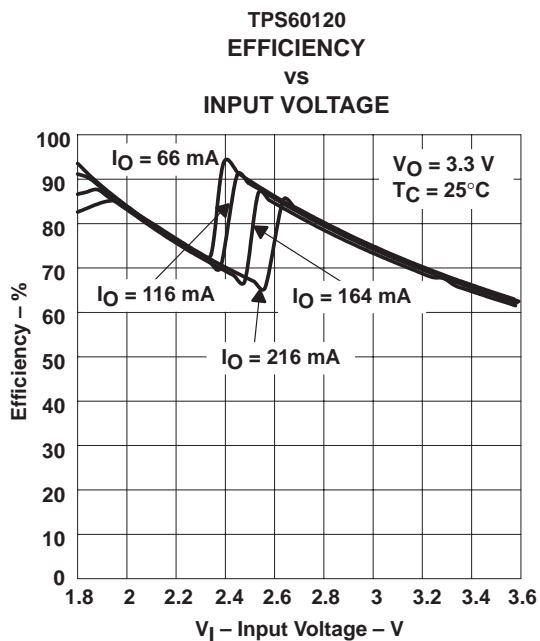

Figure 8

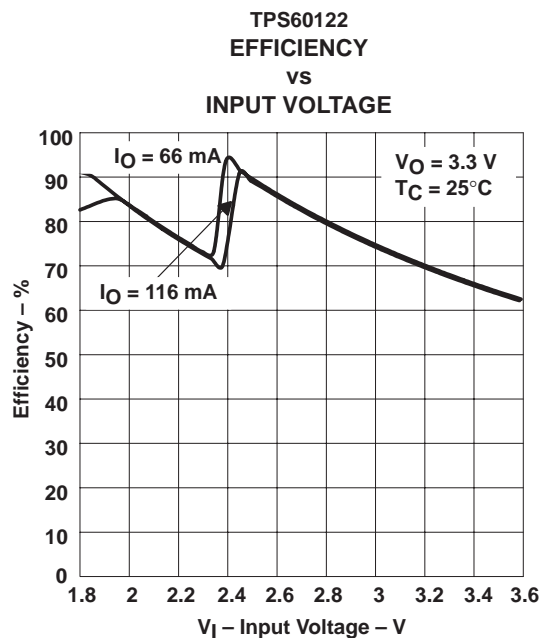

Figure 9



TPS60120, TPS60121, TPS60122, TPS60123
REGULATED 3.3 V, 200-mA HIGH EFFICIENCY CHARGE PUMP
DC/DC CONVERTERS

SLVS257A – NOVEMBER 1999 – REVISED DECEMBER 1999

TYPICAL CHARACTERISTICS

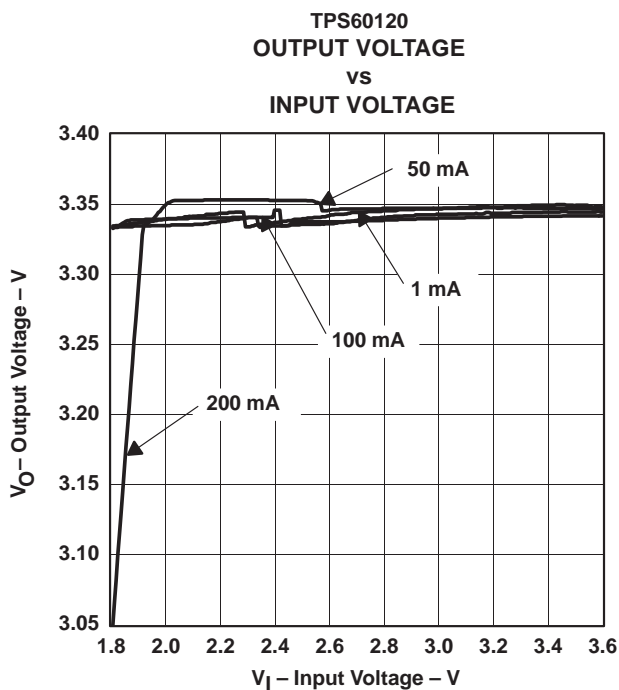
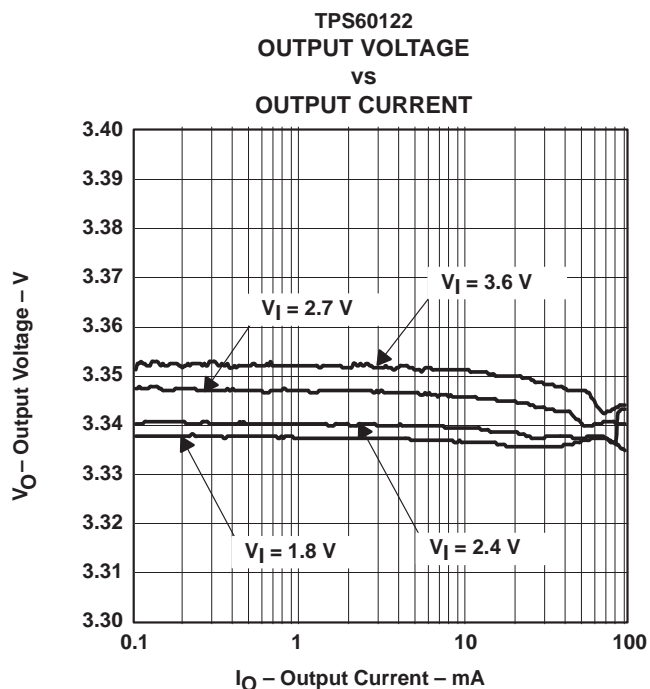
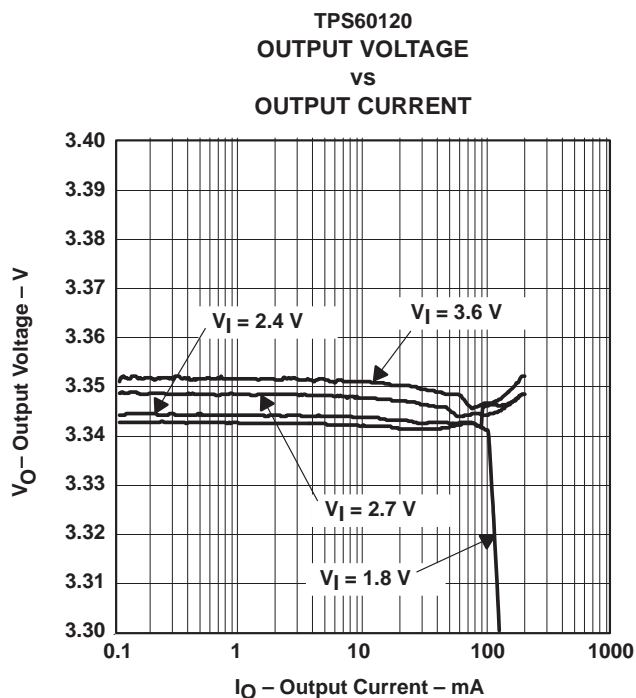
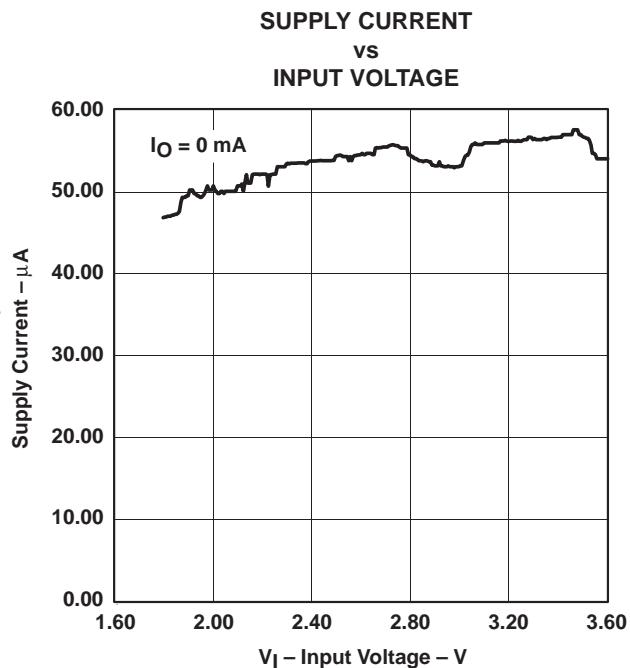

TPS60120, TPS60121, TPS60122, TPS60123
 REGULATED 3.3 V, 200-mA HIGH EFFICIENCY CHARGE PUMP
 DC/DC CONVERTERS

SLVS257A – NOVEMBER 1999 – REVISED DECEMBER 1999

TYPICAL CHARACTERISTICS

TPS60122
 OUTPUT VOLTAGE
 VS
 INPUT VOLTAGE

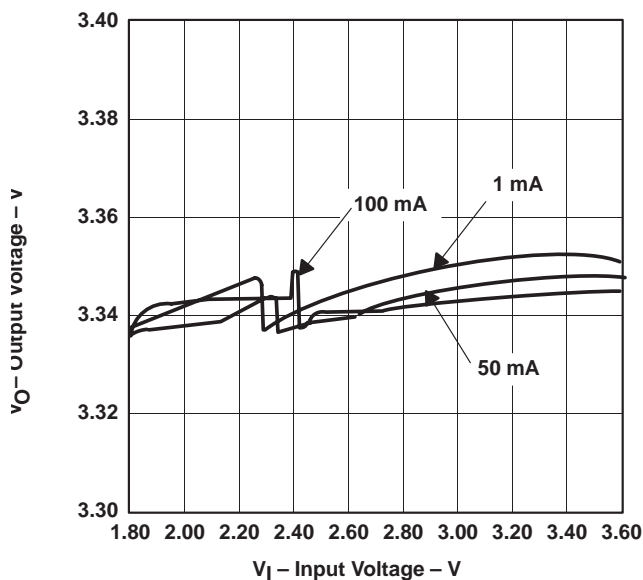

Figure 14

OUTPUT VOLTAGE RIPPLE
 VS
 TIME

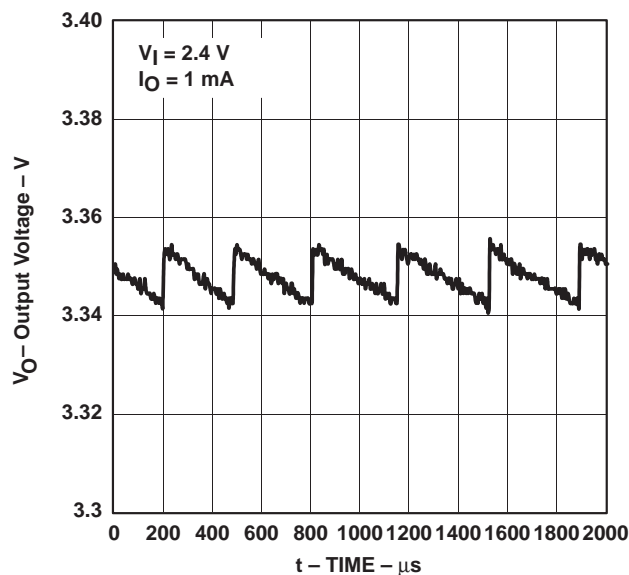

Figure 15

OUTPUT VOLTAGE RIPPLE
 VS
 TIME

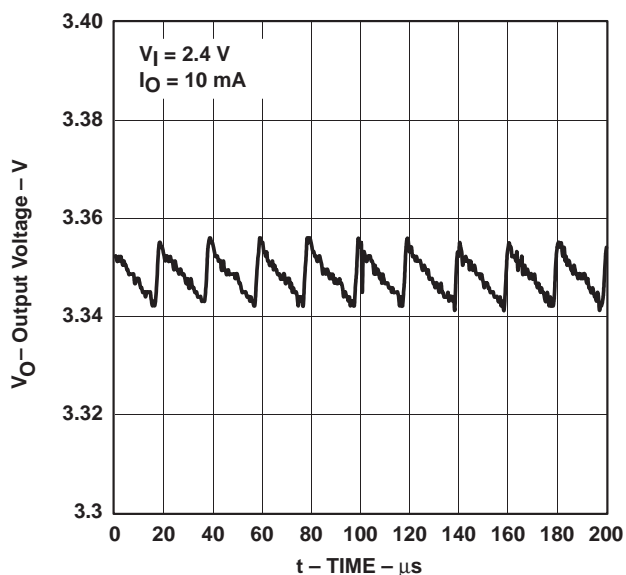

Figure 16

OUTPUT VOLTAGE RIPPLE
 VS
 TIME

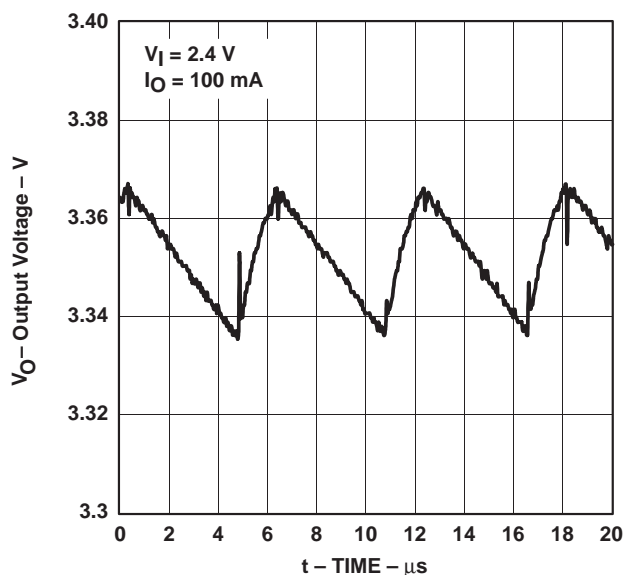

Figure 17



TPS60120, TPS60121, TPS60122, TPS60123
REGULATED 3.3 V, 200-mA HIGH EFFICIENCY CHARGE PUMP
DC/DC CONVERTERS

SLVS257A – NOVEMBER 1999 – REVISED DECEMBER 1999

TYPICAL CHARACTERISTICS

OUTPUT VOLTAGE RIPPLE AMPLITUDE
vs
INPUT VOLTAGE

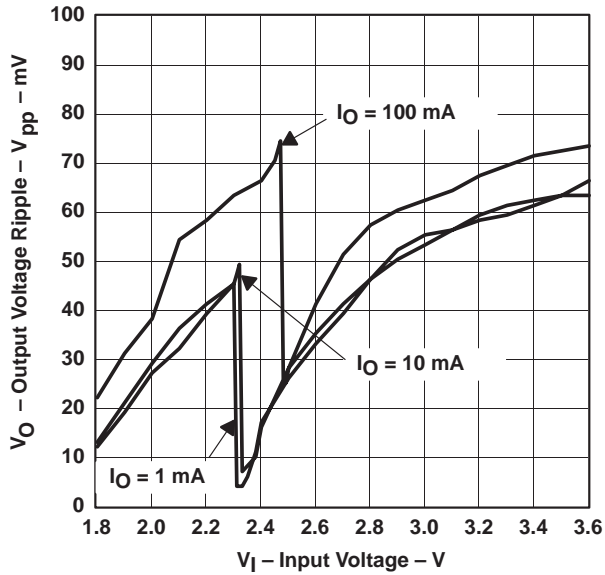

Figure 18

OSCILLATOR FREQUENCY
vs
INPUT VOLTAGE

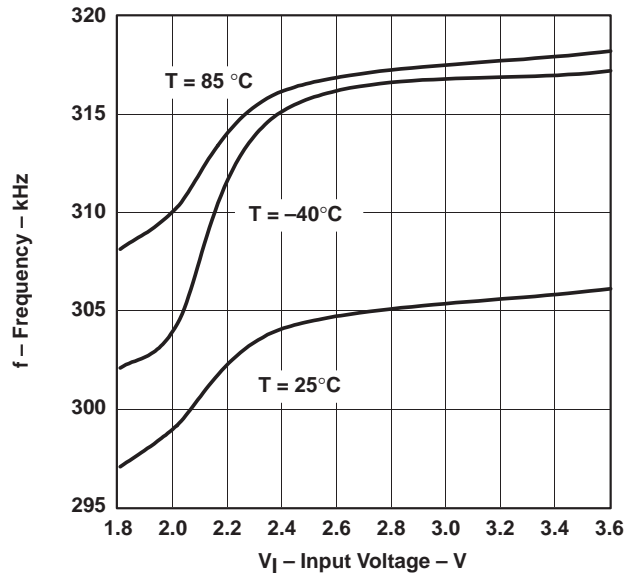

Figure 19

LOAD TRANSIENT RESPONSE

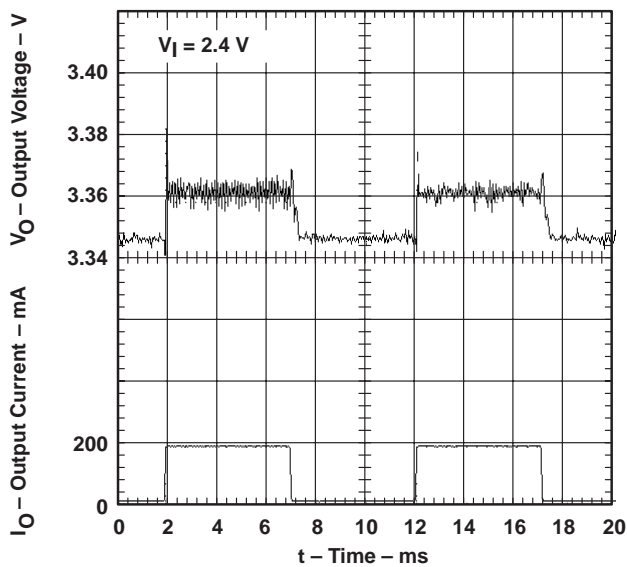

Figure 20

LINE TRANSIENT RESPONSE

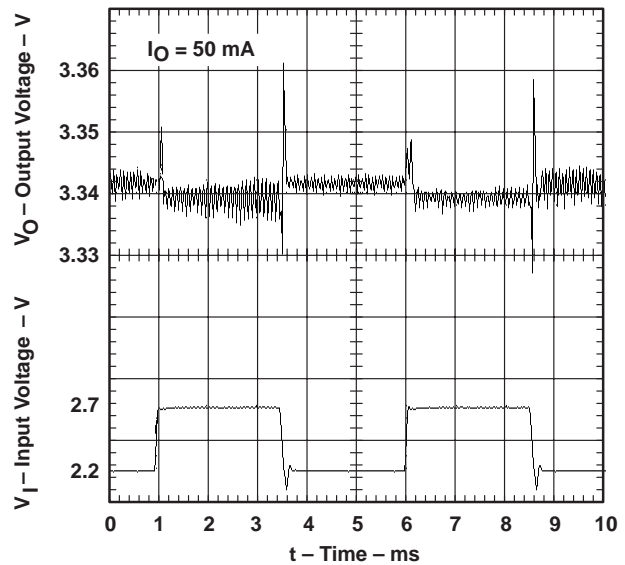

Figure 21



TPS60120, TPS60121, TPS60122, TPS60123
REGULATED 3.3 V, 200-mA HIGH EFFICIENCY CHARGE PUMP
DC/DC CONVERTERS

SLVS257A – NOVEMBER 1999 – REVISED DECEMBER 1999

TYPICAL CHARACTERISTICS

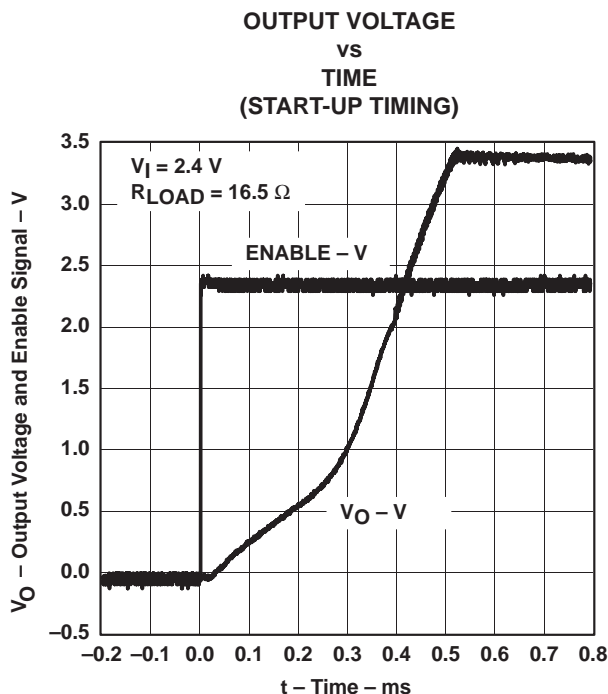

Figure 22

APPLICATION INFORMATION

capacitor selection

The TPS6012x charge pumps require only four external capacitors as shown in the basic application circuit. Their values and types are closely linked to the output current and output noise/ripple requirements. For lowest noise and ripple, low ESR ($<0.1 \Omega$) capacitors should be used for input and output capacitors.

The input capacitor improves system efficiency by reducing the input impedance. It also stabilizes the input current of the power source. The input capacitor should be chosen according to the power supply used and the distance from the power source to the converter IC. The input capacitor also has an impact on the output ripple requirements. The lower the ESR of the input capacitor C_i , the lower is the output ripple. C_i is recommended to be about two to four times as large as $C_{(XF)}$.

The output capacitor C_o can be selected from 5-times to 50-times larger than $C_{(XF)}$, depending on the ripple tolerance. The larger C_o and the lower its ESR, the lower will be the output voltage ripple. C_i and C_o can be either ceramic or low-ESR tantalum; aluminum capacitors are not recommended.



TPS60120, TPS60121, TPS60122, TPS60123
REGULATED 3.3 V, 200-mA HIGH EFFICIENCY CHARGE PUMP
DC/DC CONVERTERS

SLVS257A – NOVEMBER 1999 – REVISED DECEMBER 1999

APPLICATION INFORMATION

capacitor selection (continued)

Generally, the flying capacitors $C_{(XF)}$ will be the smallest. Only ceramic capacitors are recommended because they are low ESR and because they retain their capacitance at the switching frequency. Because the device regulates the output voltage with the pulse-skip technique, a larger flying capacitor will lead to a higher output voltage ripple if the size of the output capacitor is not increased. Be aware that, depending on the material used to manufacture them, ceramic capacitors might lose their capacitance over temperature and voltage. Ceramic capacitors of type X7R or X5R material will keep their capacitance over temperature and voltage, whereas Z5U or Y5V-type capacitors will decrease in capacitance. Table 2 lists recommended capacitor values.

Table 2. Recommended Capacitor Values

PART	V _I (V)	I _O (mA)	C _i (μF)		C _(XF) (μF)	C _o (μF)		V _{ppTYP} (mV)
			TANTALUM	CERAMIC (X7R)	CERAMIC (X7R)	TANTALUM	CERAMIC (X7R)	
TPS60120 TPS60121	2.4	150	4.7	4.7	2.2	22	4.7	65
						22	40	
		200	10	2.2	22	4.7	80	
					10	22	35	
TPS60122 TPS60123	2.4	50		1		10	70	
		100			4.7		80	

The TPS6012x devices are charge pumps that regulate the output voltage using the pulse-skip operating mode. The output voltage ripple is therefore dependent on the values and the ESR of the input, output and flying capacitors. The only possibility to reduce the output voltage ripple is to choose the appropriate capacitors. The lowest output voltage ripple can be achieved with ceramic capacitors due to their low ESR and their frequency characteristic.

Ceramic capacitors typically have an ESR that is more than 10 times lower than tantalum capacitors and they retain their capacitance at frequencies more than 10 times higher than tantalum capacitors. Many different tantalum capacitors act as an inductance for frequencies higher than 200 kHz. This behavior increases the output voltage ripple. Therefore the best choice for a minimized ripple is the ceramic capacitor. For applications that do not need higher performance in output voltage ripple, tantalum capacitors with a low ESR are a possibility for input and output capacitor, but a ceramic capacitor should be connected in parallel. Be aware that the ESR of tantalum capacitors is indirectly proportional to the physical size of the capacitor.

Table 2 is a good starting point for choosing the capacitors. If the output voltage ripple is too high for the application, it can be improved by selecting the appropriate capacitors. The first step is to increase the capacitance at the output. If the ripple is still too high, the second step would be to increase the capacitance at the input.

For the TPS60120 and TPS60121, the smallest board space can be achieved using Sprague's 595D-series tantalum capacitors for input and output. However, with the trend towards high capacitance ceramic capacitors in smaller size packages, these types of capacitors may become more competitive in size. The smallest size for the TPS60122 and TPS60123 can be achieved using the recommended ceramic capacitors.

Tables 3 and 4 lists the manufacturers of recommended capacitors. In most applications surface-mount tantalum capacitors will be the right choice. However, ceramic capacitors provide the lowest output voltage ripple due to their typically lower ESR.



TPS60120, TPS60121, TPS60122, TPS60123
REGULATED 3.3 V, 200-mA HIGH EFFICIENCY CHARGE PUMP
DC/DC CONVERTERS

SLVS257A – NOVEMBER 1999 – REVISED DECEMBER 1999

APPLICATION INFORMATION

capacitor selection (continued)

Table 3. Recommended Capacitors

MANUFACTURER	PART NUMBER	CAPACITANCE	CASE SIZE	TYPE
Taiyo Yuden	LMK212BJ105KG-T	1 μF	0805	Ceramic
	LMK212BJ225MG-T	2.2 μF	0805	Ceramic
	LMK316BJ475KL-T	4.7 μF	1206	Ceramic
	LMK325BJ106MN-T	10 μF	1210	Ceramic
	LMK432BJ226MM-T	22 μF	1812	Ceramic
AVX	0805ZC105KAT2A	1 μF	0805	Ceramic
	1206ZC225KAT2A	2.2 μF	1206	Ceramic
	TPSC475035R0600	4.7 μF	Case C	Tantalum
	TPSC106025R0500	10 μF	Case C	Tantalum
	TPSC226016R0375	22 μF	Case C	Tantalum
Sprague	595D106X0016B2T	10 μF	Case B	Tantalum
	595D226X06R3B2T	22 μF	Case B	Tantalum
	595D226X0020C2T	22 μF	Case B	Tantalum
Kemet	T494C156K010AS	10 μF	Case C	Tantalum
	T494C226M010AS	22 μF	Case C	Tantalum

NOTE: Case code compatibility with EIA 535BAAC and CECC30801 molded chips.

Table 4. Recommended Capacitor Manufacturers

MANUFACTURER	CAPACITOR TYPE	INTERNET SITE
Taiyo Yuden	X7R/X5R ceramic	http://www.t-yuden.com/
AVX	X7R/X5R ceramic	http://www.avxcorp.com/
	TPS-series tantalum	
Sprague	595D-series tantalum	http://www.vishay.com/
	593D-series tantalum	
Kemet	T494-series tantalum	http://www.kemet.com/

power dissipation

The power dissipated in the TPS6012x depends on output current and mode of operation (1.5x or doubler voltage conversion mode). It is described by the following:

$$P_{DISS} = \left(\frac{1}{\eta} - 1\right) V_O \times I_O \quad (\text{Efficiency } \eta \text{ mainly depends on } V_I \text{ and also on } I_O. \text{ See efficiency graphs.})$$

P_{DISS} must be less than that allowed by the package rating. See the absolute maximum ratings for 20-pin PWP package power-dissipation limits and deratings.



TPS60120, TPS60121, TPS60122, TPS60123
REGULATED 3.3 V, 200-mA HIGH EFFICIENCY CHARGE PUMP
DC/DC CONVERTERS

SLVS257A – NOVEMBER 1999 – REVISED DECEMBER 1999

APPLICATION INFORMATION

board layout

Careful board layout is necessary due to the high transient currents and switching frequency of the converter. All capacitors should be soldered in close proximity to the IC. Connect ground and power ground pins through a short, low-impedance trace. A PCB layout proposal for a two-layer board is given in Figure 23. The bottom layer of the board carries only ground potential for best performance. The layout also provides improved performance as the exposed frame is soldered to the PCB.

An evaluation module for the TPS60120 is available and can be ordered under product code TPS60120EVM-142. The EVM uses the layout shown in Figure 23. The layout also provides improved thermal performance as the exposed leadframe of the PowerPAD package can be soldered to the PCB.

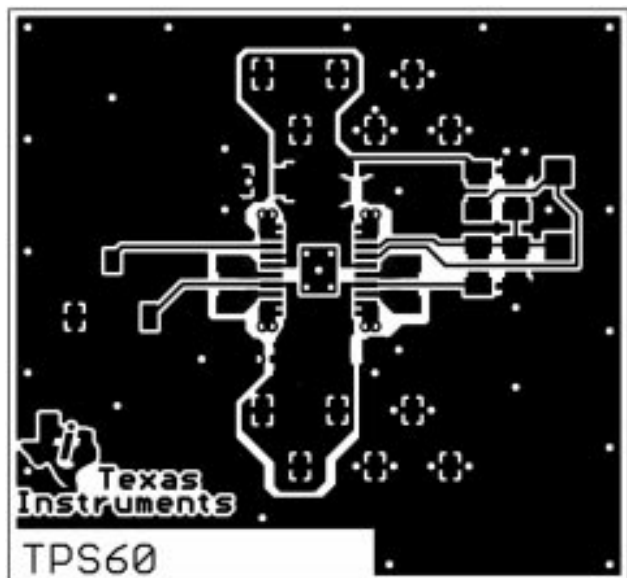

Figure 23. Recommended PCB Layout for TPS6012X

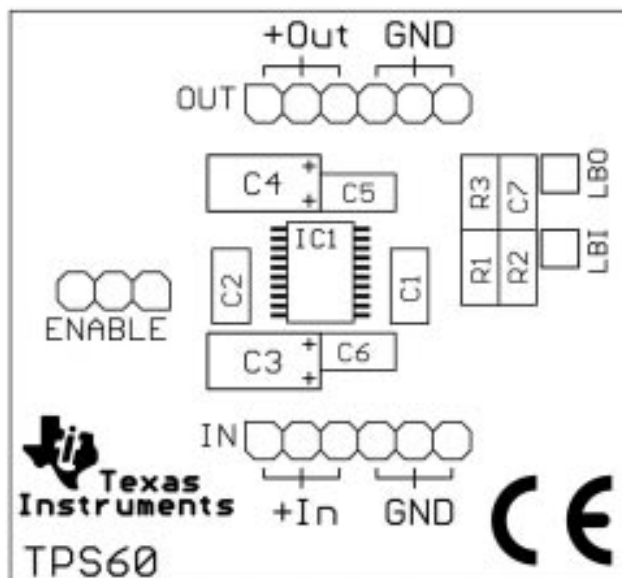

Figure 24. Component Placement

Table 5. Component Identification

IC1	TPS6012x
C1, C2	Flying capacitors
C3, C6	Input capacitors
C4, C5	Output capacitors
C7	Stabilization capacitor for LBI
R1, R2	Resistive divider for LBI
R3	Pullup resistor for LBO

The best performance of the converter is achieved with the additional bypass capacitors C5 and C6 at input and output. Capacitor C7 should be included if the large line transients are expected. The capacitors are not required. They can be omitted in most applications.

TPS60120, TPS60121, TPS60122, TPS60123 REGULATED 3.3 V, 200-mA HIGH EFFICIENCY CHARGE PUMP DC/DC CONVERTERS

SLVS257A – NOVEMBER 1999 – REVISED DECEMBER 1999

APPLICATION INFORMATION

application proposals

paralleling of two TPS6012x to deliver 400 mA total output current

Two TPS6012x devices can be connected in parallel to yield higher load currents. The circuit of Figure 25 can deliver up to 400 mA at an output voltage of 3.3 V. The devices can share the output capacitors, but each one requires its own transfer capacitors and input capacitor. If both a TPS60120 and a TPS60121 are used, it is possible to monitor the battery voltage with the TPS60120 using the low-battery comparator function and to supervise the output voltage with the TPS60121 using the power-good comparator. Make the layout of the charge pumps as similar as possible, and position the output capacitor the same distance from both devices.

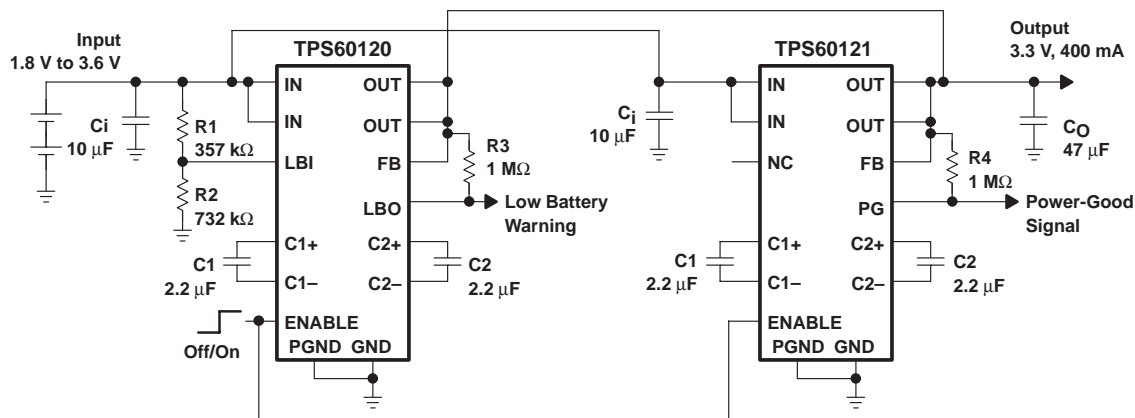

Figure 25. Paralleling of Two TPS6012x Charge Pumps

TPS60120, TPS60121, TPS60122, TPS60123 REGULATED 3.3 V, 200-mA HIGH EFFICIENCY CHARGE PUMP DC/DC CONVERTERS

SLVS257A – NOVEMBER 1999 – REVISED DECEMBER 1999

APPLICATION INFORMATION

TPS6012x operated with ultra-low quiescent current

Because the output of the TPS6012x is isolated from the input when the devices are disabled, and because the internal resistive divider is disconnected in shutdown, an ultra-low quiescent current mode can be implemented. In this mode, the output voltage is sustained because the converter is periodically enabled to refresh the output capacitor. The necessary external control signal that is applied to the ENABLE pin is generated from a microcontroller like the ultra-low power microcontroller MSP430. For a necessary supply current for the system of 1 mA and a minimum supply voltage of 3 V with a 22- μ F output capacitor, the refresh has to be done after a maximum of 3.5 ms. Longer refresh periods can be achieved with a larger output capacitor.

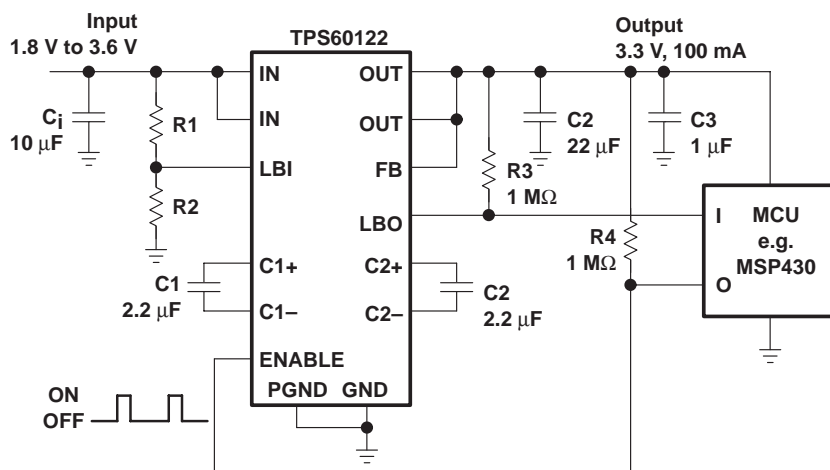

Figure 26. TPS60122 in Ultra-Low Quiescent Current Mode

regulated discharge of the output capacitors after disabling of the TPS6012x

During shutdown of the charge pump TPS6012x, the output is isolated from the input. Therefore, the discharging of the output capacitor depends on the load and on the leakage current of the capacitor. In certain applications it is necessary to completely remove the supply voltage from the load in shutdown mode. That means the output capacitor of the charge pump has to be actively discharged when the charge pump is disabled. Figure 27 shows one solution to this problem.

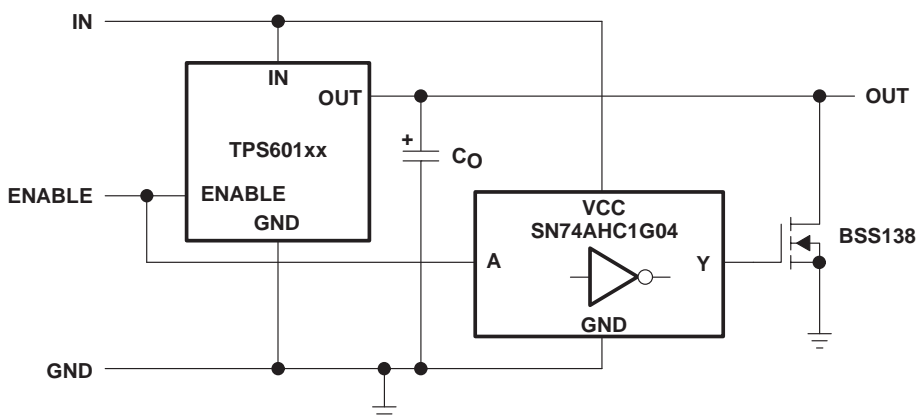

Figure 27. Block Diagram of the Regulated Discharge of the Output Capacitor

TPS60120, TPS60121, TPS60122, TPS60123 REGULATED 3.3 V, 200-mA HIGH EFFICIENCY CHARGE PUMP DC/DC CONVERTERS

SLVS257A – NOVEMBER 1999 – REVISED DECEMBER 1999

APPLICATION INFORMATION

related information

application reports

For more application information see:

- PowerPAD™ Application Report, Literature Number SLMA002
- *TPS6010x/TPS6011x Charge Pump Application Report*, Literature Number SLVA070
- Designer Note Page: Powering the TMS320C5420 Using the TPS60100, TPS76918, and the TPS3305-18, Literature Number SLVA082.

device family products

Other devices in this family are:

PART NUMBER	DATASHEET LITERATURE CODE	DESCRIPTION
TPS60100	SLVS213B	Regulated 3.3-V, 200-mA low-noise charge pump dc-dc converter
TPS60101	SLVS214A	Regulated 3.3-V, 100-mA low-noise charge pump dc-dc converter
TPS60110	SLVS215A	Regulated 5-V, 300-mA low-noise charge pump dc-dc converter
TPS60111	SLVS216A	Regulated 5-V, 150-mA low-noise charge pump dc-dc converter
TPS60130	SLVS258	Regulated 5-V, 300-mA high efficiency charge pump dc-dc converter with low-battery comparator
TPS60131	SLVS258	Regulated 5-V, 300-mA high efficiency charge pump dc-dc converter with power-good comparator
TPS60132	SLVS258	Regulated 5-V, 150-mA high efficiency charge pump dc-dc converter with low-battery comparator
TPS60133	SLVS258	Regulated 5-V, 150-mA high efficiency charge pump dc-dc converter with power-good comparator



TPS60120, TPS60121, TPS60122, TPS60123
REGULATED 3.3 V, 200-mA HIGH EFFICIENCY CHARGE PUMP
DC/DC CONVERTERS

SLVS257A – NOVEMBER 1999 – REVISED DECEMBER 1999

MECHANICAL DATA

PWP (R-PDSO-G)**

PowerPAD™ PLASTIC SMALL-OUTLINE

20 PINS SHOWN

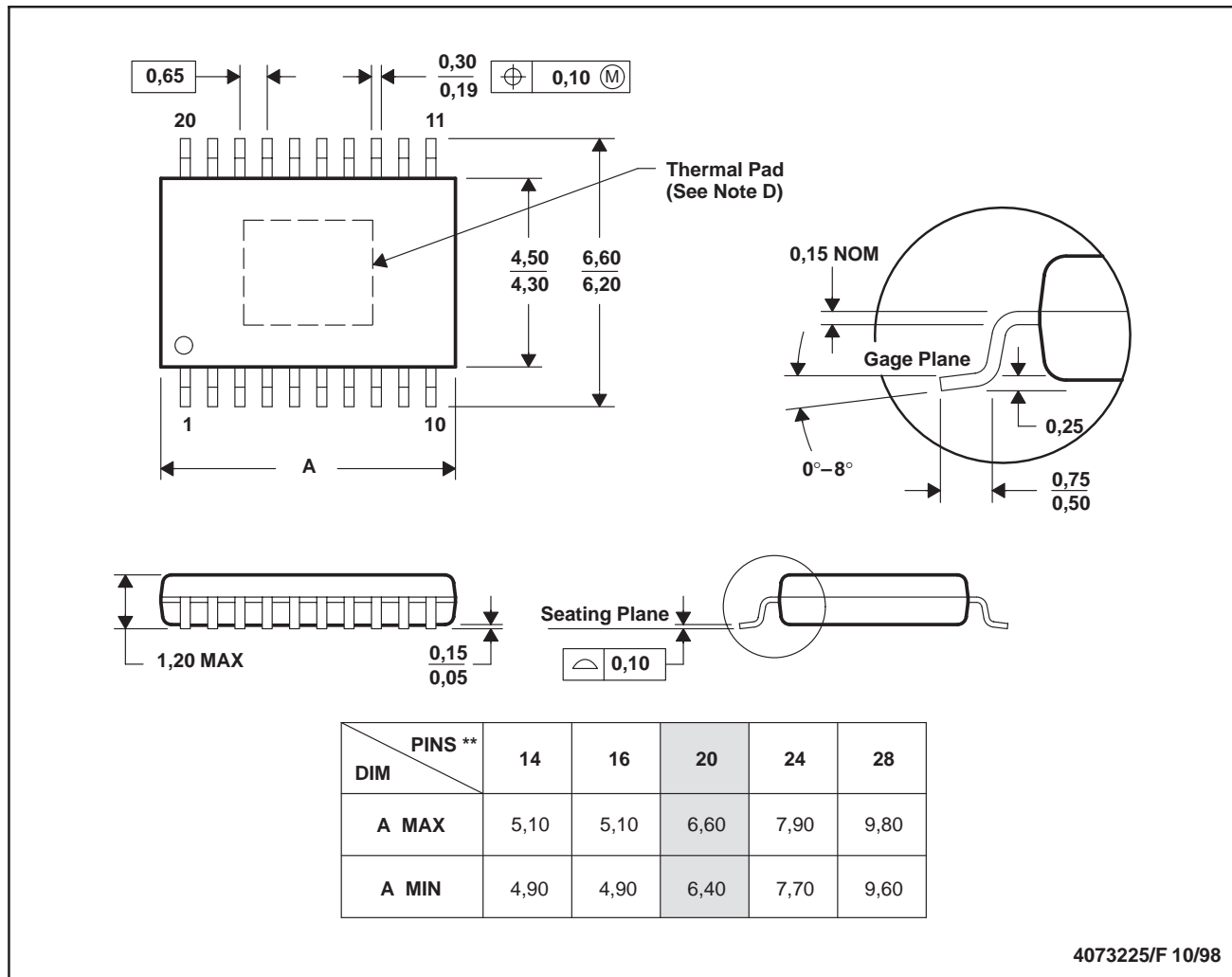

4073225/F 10/98

- NOTES: A. All linear dimensions are in millimeters.
 B. This drawing is subject to change without notice.
 C. Body dimensions do not include mold flash or protrusions.
 D. The package thermal performance may be enhanced by bonding the thermal pad to an external thermal plane. This pad is electrically and thermally connected to the backside of the die and possibly selected leads.
 E. Falls within JEDEC MO-153

PowerPAD is a trademark of Texas Instruments Incorporated.



POST OFFICE BOX 655303 • DALLAS, TEXAS 75265

IMPORTANT NOTICE

Texas Instruments and its subsidiaries (TI) reserve the right to make changes to their products or to discontinue any product or service without notice, and advise customers to obtain the latest version of relevant information to verify, before placing orders, that information being relied on is current and complete. All products are sold subject to the terms and conditions of sale supplied at the time of order acknowledgement, including those pertaining to warranty, patent infringement, and limitation of liability.

TI warrants performance of its semiconductor products to the specifications applicable at the time of sale in accordance with TI's standard warranty. Testing and other quality control techniques are utilized to the extent TI deems necessary to support this warranty. Specific testing of all parameters of each device is not necessarily performed, except those mandated by government requirements.

CERTAIN APPLICATIONS USING SEMICONDUCTOR PRODUCTS MAY INVOLVE POTENTIAL RISKS OF DEATH, PERSONAL INJURY, OR SEVERE PROPERTY OR ENVIRONMENTAL DAMAGE ("CRITICAL APPLICATIONS"). TI SEMICONDUCTOR PRODUCTS ARE NOT DESIGNED, AUTHORIZED, OR WARRANTED TO BE SUITABLE FOR USE IN LIFE-SUPPORT DEVICES OR SYSTEMS OR OTHER CRITICAL APPLICATIONS. INCLUSION OF TI PRODUCTS IN SUCH APPLICATIONS IS UNDERSTOOD TO BE FULLY AT THE CUSTOMER'S RISK.

In order to minimize risks associated with the customer's applications, adequate design and operating safeguards must be provided by the customer to minimize inherent or procedural hazards.

TI assumes no liability for applications assistance or customer product design. TI does not warrant or represent that any license, either express or implied, is granted under any patent right, copyright, mask work right, or other intellectual property right of TI covering or relating to any combination, machine, or process in which such semiconductor products or services might be or are used. TI's publication of information regarding any third party's products or services does not constitute TI's approval, warranty or endorsement thereof.