

**SN54153, SN54LS153, SN54S153
SN74153, SN74LS153, SN74S153
DUAL 4-LINE TO 1-LINE DATA SELECTORS/MULTIPLEXERS**

DECEMBER 1972 — REVISED MARCH 1988

- Permits Multiplexing from N lines to 1 line
- Performs Parallel-to-Serial Conversion
- Strobe (Enable) Line Provided for Cascading (N lines to n lines)
- High-Fan-Out, Low-Impedance, Totem-Pole Outputs
- Fully Compatible with most TTL Circuits

SN54153, SN54LS153, SN54S153 . . . J OR W PACKAGE
SN74153 . . . N PACKAGE
SN74LS153, SN74S153 . . . D OR N PACKAGE

(TOP VIEW)

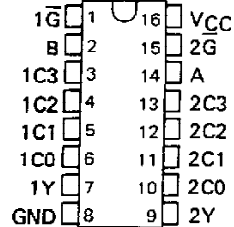

SN54LS153, SN54S153 . . . FK PACKAGE
(TOP VIEW)

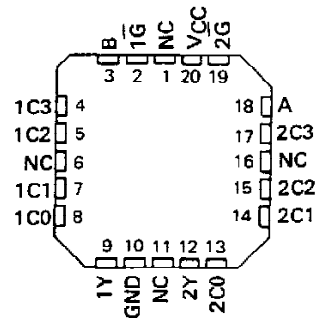

NC - No internal connection

TYPE	TYPICAL AVERAGE PROPAGATION DELAY TIMES			TYPICAL POWER DISSIPATION
	FROM DATA	FROM STROBE	FROM SELECT	
'153	14 ns	17 ns	22 ns	180 mW
'LS153	14 ns	19 ns	22 ns	31 mW
'S153	6 ns	9.5 ns	12 ns	225 mW

description

Each of these monolithic, data selectors/multiplexers contains inverters and drivers to supply fully complementary, on-chip, binary decoding data selection to the AND-OR gates. Separate strobe inputs are provided for each of the two four-line sections.

FUNCTION TABLE

SELECT INPUTS		DATA INPUTS				STROBE	OUTPUT
B	A	C0	C1	C2	C3	Ḡ	Y
X	X	X	X	X	X	H	L
L	L	L	X	X	X	L	L
L	L	H	X	X	X	L	H
L	H	X	L	X	X	L	L
L	H	X	H	X	X	L	H
H	L	X	X	L	X	L	L
H	L	X	X	H	X	L	H
H	H	X	X	X	L	L	L
H	H	X	X	X	H	L	H

Select inputs A and B are common to both sections.
H = high level, L = low level, X = irrelevant

absolute maximum ratings over operating free-air temperature range (unless otherwise noted)

Supply voltage, V _{CC} (See Note 1)	7 V
Input voltage: '153, 'S153	5.5 V
'LS153	7 V
Operating free-air temperature range: SN54'	-55°C to 125°C
SN74'	0°C to 70°C
Storage temperature range	-65°C to 150°C

NOTE 1: Voltage values are with respect to network ground terminal.

PRODUCTION DATA documents contain information current as of publication date. Products conform to specifications per the terms of Texas Instruments standard warranty. Production processing does not necessarily include testing of all parameters.



POST OFFICE BOX 855012 • DALLAS, TEXAS 75265

SN54153, SN54LS153, SN54S153
SN74153, SN74LS153, SN74S153
DUAL 4-LINE TO 1-LINE DATA SELECTORS/MULTIPLEXERS

logic symbol[†]

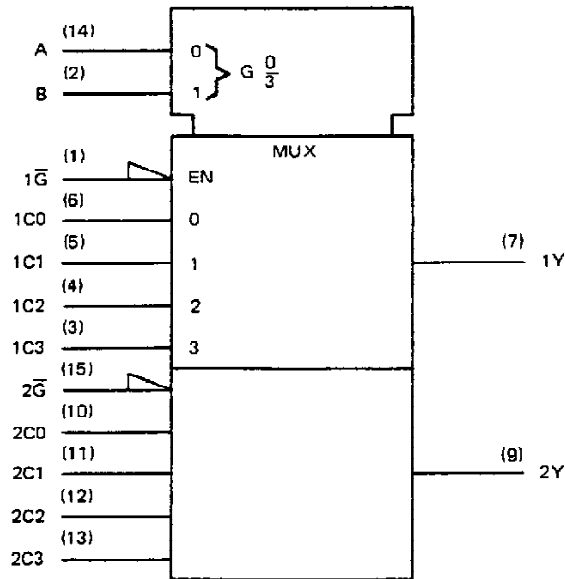

[†]This symbol is in accordance with ANSI/IEEE Std. 91-1984 and IEC Publication 617-12.

logic diagrams (positive logic)

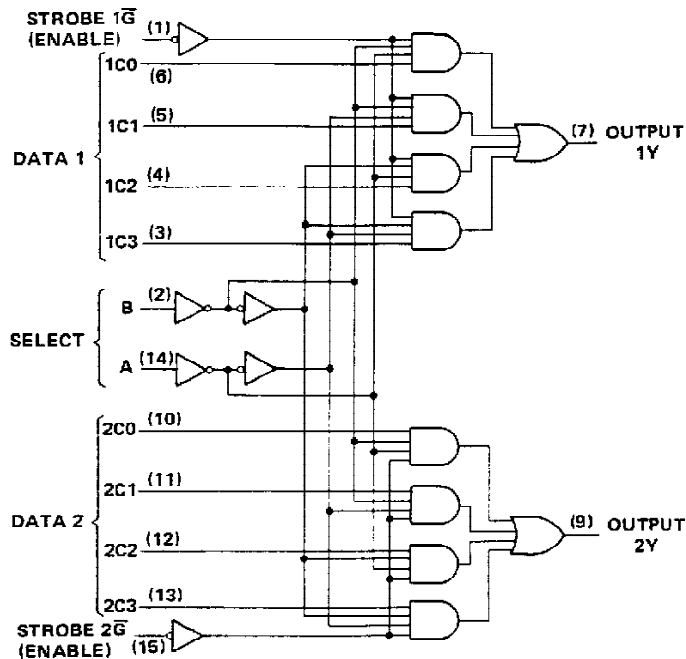

Pin numbers shown are for D, J, N, and W packages.



POST OFFICE BOX 655012 • DALLAS, TEXAS 75205

**SN54153, SN54LS153, SN54S153
SN74153, SN74LS153, SN74S153
DUAL 4-LINE TO 1-LINE DATA SELECTORS/MULTIPLEXERS**

schematics of inputs and outputs

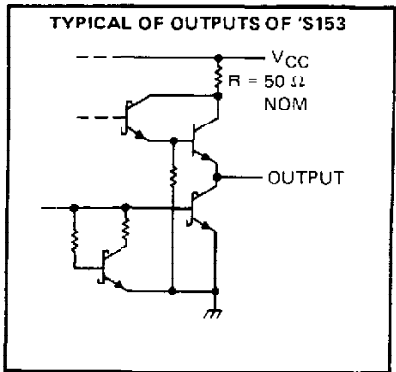
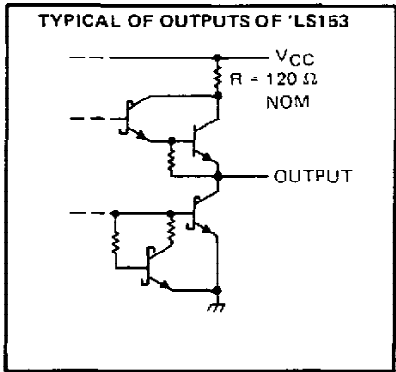
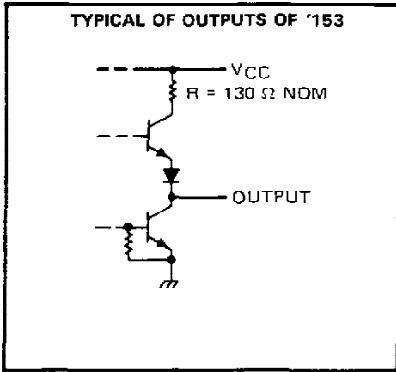
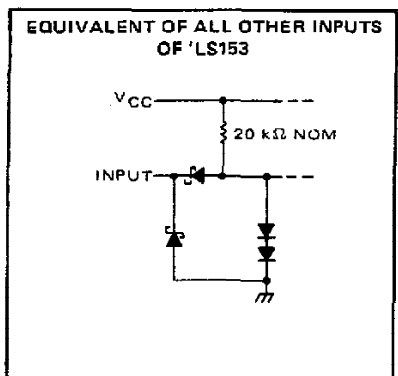
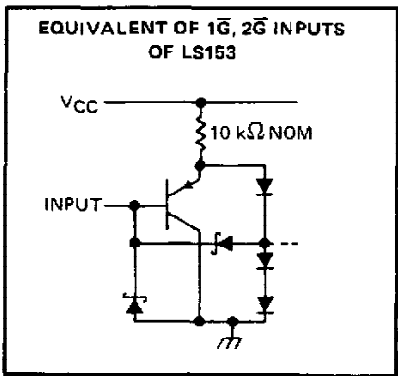
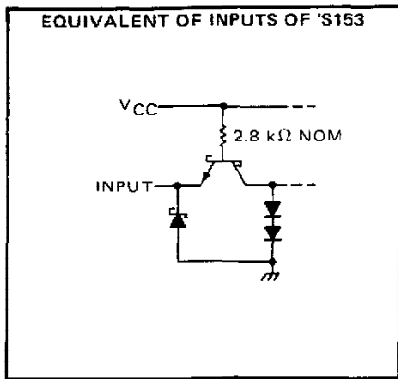
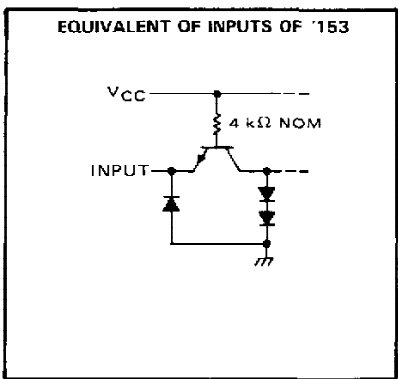

SN54153, SN74153 DUAL 4-LINE TO 1-LINE DATA SELECTORS/MULTIPLEXERS

recommended operating conditions

	SN54153			SN74153			UNIT
	MIN	NOM	MAX	MIN	NOM	MAX	
Supply voltage, V _{CC}	4.5	5	5.5	4.75	5	5.25	V
High-level output current, I _{OH}			-800			-800	μA
Low-level output current, I _{OL}			16			16	mA
Operating free-air temperature, T _A	-55		125	0		70	°C

electrical characteristics over recommended operating free-air temperature range (unless otherwise noted)

PARAMETER	TEST CONDITIONS†	SN54153			SN74153			UNIT
		MIN	TYP‡	MAX	MIN	TYP‡	MAX	
V _{IH} High-level input voltage		2			2			V
V _{IL} Low-level input voltage				0.8			0.8	V
V _{IK} Input clamp voltage	V _{CC} = MIN, I _I = -12 mA			-1.5			-1.5	V
V _{OH} High-level output voltage	V _{CC} = MIN, V _{IH} = 2 V, V _{IL} = 0.8 V, I _{OH} = -800 μA	2.4	3.4		2.4	3.4		V
V _{OL} Low-level output voltage	V _{CC} = MIN, V _{IH} = 2 V, V _{IL} = 0.8 V, I _{OL} = 16 mA		0.2	0.4		0.2	0.4	V
I _I Input current at maximum input voltage	V _{CC} = MAX, V _I = 5.5 V			1			1	mA
I _{IH} High-level input current	V _{CC} = MAX, V _I = 2.4 V			40			40	μA
I _{IL} Low-level input current	V _{CC} = MAX, V _I = 0.4 V			-1.6			-1.6	mA
I _{OS} Short-circuit output current§	V _{CC} = MAX	-20		-55	-18		-57	mA
I _{CCL} Supply current, output low	V _{CC} = MAX, See Note 2		36	52		36	60	mA

† For conditions shown as MIN or MAX, use the appropriate value specified under recommended operating conditions.

‡ All typical values are at V_{CC} = 5 V, T_A = 25°C.

§ Not more than one output should be shorted at a time.

NOTE 2: I_{CCL} is measured with the outputs open and all inputs grounded.

switching characteristics, V_{CC} = 5 V, T_A = 25°C

PARAMETER†	FROM (INPUT)	TO (OUTPUT)	TEST CONDITIONS	MIN	TYP	MAX	UNIT
t _{PLH}	Data	Y	C _L = 30 pF, R _L = 400 Ω, See Note 3		12	18	ns
t _{PHL}	Data	Y			15	23	ns
t _{PLH}	Select	Y			22	34	ns
t _{PHL}	Select	Y			22	34	ns
t _{PLH}	Strobe \bar{G}	Y			19	30	ns
t _{PHL}	Strobe \bar{G}	Y			15	23	ns

† t_{PLH} = propagation delay time, low-to-high-level output

t_{PHL} = propagation delay time, high-to-low-level output

NOTE 3: Load circuits and voltage waveforms are shown in Section 1.



POST OFFICE BOX 655012 • DALLAS, TEXAS 75265

SN54LS153, SN74LS153
DUAL 4-LINE TO 1-LINE DATA SELECTORS/MULTIPLEXERS

recommended operating conditions

	SN54LS153			SN74LS153			UNIT
	MIN	NOM	MAX	MIN	NOM	MAX	
V _{CC} Supply voltage	4.5	5	5.5	4.75	5	5.25	V
V _{IH} High-level input voltage	2			2			V
V _{IL} Low-level input voltage			0.7			0.8	V
I _{OH} High-level output current			-0.4			-0.4	mA
I _{OL} Low-level output current			4			8	mA
T _A Operating free-air temperature	-55		125	0		70	°C

electrical characteristics over recommended operating free-air temperature range (unless otherwise noted)

PARAMETER	TEST CONDITIONS †		SN54LS153			SN74LS153			UNIT
			MIN	TYP ‡	MAX	MIN	TYP ‡	MAX	
V _{IK}	V _{CC} = MIN, I _I = -18 mA				-1.5			-1.5	V
V _{OH}	V _{CC} = MIN, V _{IH} = 2 V, V _{IL} = MAX I _{OH} = -0.4 mA		2.5	3.4		2.7	3.4		V
V _{OL}	V _{CC} = MIN, V _{IH} = 2 V, V _{IL} = MAX	I _{OL} = 4 mA	0.25		0.4	0.25		0.4	V
		I _{OL} = 8 mA				0.35		0.5	
I _I	V _{CC} = MAX, V _I = 7 V					0.1			mA
I _{IH}	V _{CC} = MAX, V _I = 2.7 V					20			μA
I _{IL}	1G, 2G	V _{CC} = MAX, V _I = 0.4 V				-0.2			mA
	All other					-0.4			
I _{OS} §	V _{CC} = MAX		-20		-100	-20		-100	mA
I _{CCL}	V _{CC} = MAX, See Note 2		6.2		10	6.2		10	mA

† For conditions shown as MIN or MAX, use the appropriate value specified under recommended operating conditions.

‡ All typical values are at V_{CC} = 5 V, T_A = 25°C.

§ Not more than one output should be shorted at a time.

NOTE 2: I_{CCL} is measured with the outputs open and all inputs grounded.

switching characteristics, V_{CC} = 5 V, T_A = 25°C

PARAMETER †	FROM (INPUT)	TO (OUTPUT)	TEST CONDITIONS			MIN	TYP	MAX	UNIT
t _{PLH}	Data	Y	C _L = 15 pF, R _L = 2 kΩ, See Note 3			10	15		ns
t _{PHL}	Data	Y				17	26		ns
t _{PLH}	Select	Y				19	29		ns
t _{PHL}	Select	Y				25	38		ns
t _{PLH}	Strobe \overline{G}	Y				16	24		ns
t _{PHL}	Strobe G	Y				21	32		ns

† t_{PLH} = propagation delay time, low-to-high-level output

t_{PHL} = propagation delay time, high-to-low-level output

NOTE 3: Load circuits and voltage waveforms are shown in Section 1.

SN54S153, SN74S153 DUAL 4-LINE TO 1-LINE DATA SELECTORS/MULTIPLEXERS

recommended operating conditions

	SN54S153			SN74S153			UNIT
	MIN	NOM	MAX	MIN	NOM	MAX	
Supply voltage, V _{CC}	4.5	5	5.5	4.75	5	5.25	V
High-level output current, I _{OH}			-1			-1	mA
Low-level output current, I _{OL}			20			20	mA
Operating free-air temperature, T _A	-55		125	0		70	°C

electrical characteristics over recommended operating free-air temperature range (unless otherwise noted)

PARAMETER	TEST CONDITIONS†	MIN	TYP‡	MAX	UNIT
V _{IH} High-level input voltage		2			V
V _{IL} Low-level input voltage				0.8	V
V _{IK} Input clamp voltage	V _{CC} = MIN, I _I = -18 mA			-1.2	V
V _{OH} High-level output voltage	V _{CC} = MIN, V _{IH} = 2 V, I _{OH} = -1 mA				
	Series 54S	2.5	3.4		V
V _{OL} Low-level output voltage	V _{CC} = MIN, V _{IH} = 2 V, I _{OL} = 20 mA				
	Series 74S	2.7	3.4		V
I _I Input current at maximum input voltage	V _{CC} = MAX, V _I = 5.5 V			1	mA
I _{IH} High-level input current	V _{CC} = MAX, V _I = 2.7 V			50	μA
I _{IL} Low-level input current	V _{CC} = MAX, V _I = 0.5 V			-2	mA
I _{OS} Short-circuit output current‡	V _{CC} = MAX	-40		-100	mA
I _{CCL} Supply current, low-level output	V _{CC} = MAX, See Note 2		45	70	mA

†For conditions shown as MIN or MAX, use the appropriate value specified under recommended operating conditions.

‡All typical values are at V_{CC} = 5 V, T_A = 25°C.

§Not more than one output should be shorted at a time and duration of short-circuit should not exceed one second.

NOTE 2: I_{CCL} is measured with the outputs open and all inputs grounded.

switching characteristics, V_{CC} = 5 V, T_A = 25°C

PARAMETER¶	FROM (INPUT)	TO (OUTPUT)	TEST CONDITIONS	MIN	TYP	MAX	UNIT
t _{PLH}	Data	Y	C _L = 15 pF, R _L = 280 Ω. See Note 3		6	9	ns
t _{PHL}	Data	Y			6	9	ns
t _{PLH}	Select	Y			11.5	18	ns
t _{PHL}	Select	Y			12	18	ns
t _{PLH}	Strobe \bar{G}	Y			10	15	ns
t _{PHL}	Strobe \bar{G}	Y			9	13.5	ns

¶t_{PLH} = propagation delay time, low-to-high-level output

t_{PHL} = propagation delay time, high-to-low-level output

NOTE 3: Load circuits and voltage waveforms are shown in Section 1.

IMPORTANT NOTICE

Texas Instruments (TI) reserves the right to make changes to its products or to discontinue any semiconductor product or service without notice, and advises its customers to obtain the latest version of relevant information to verify, before placing orders, that the information being relied on is current.

TI warrants performance of its semiconductor products and related software to the specifications applicable at the time of sale in accordance with TI's standard warranty. Testing and other quality control techniques are utilized to the extent TI deems necessary to support this warranty. Specific testing of all parameters of each device is not necessarily performed, except those mandated by government requirements.

Certain applications using semiconductor products may involve potential risks of death, personal injury, or severe property or environmental damage ("Critical Applications").

TI SEMICONDUCTOR PRODUCTS ARE NOT DESIGNED, INTENDED, AUTHORIZED, OR WARRANTED TO BE SUITABLE FOR USE IN LIFE-SUPPORT APPLICATIONS, DEVICES OR SYSTEMS OR OTHER CRITICAL APPLICATIONS.

Inclusion of TI products in such applications is understood to be fully at the risk of the customer. Use of TI products in such applications requires the written approval of an appropriate TI officer. Questions concerning potential risk applications should be directed to TI through a local SC sales office.

In order to minimize risks associated with the customer's applications, adequate design and operating safeguards should be provided by the customer to minimize inherent or procedural hazards.

TI assumes no liability for applications assistance, customer product design, software performance, or infringement of patents or services described herein. Nor does TI warrant or represent that any license, either express or implied, is granted under any patent right, copyright, mask work right, or other intellectual property right of TI covering or relating to any combination, machine, or process in which such semiconductor products or services might be or are used.

IMPORTANT NOTICE

Texas Instruments and its subsidiaries (TI) reserve the right to make changes to their products or to discontinue any product or service without notice, and advise customers to obtain the latest version of relevant information to verify, before placing orders, that information being relied on is current and complete. All products are sold subject to the terms and conditions of sale supplied at the time of order acknowledgement, including those pertaining to warranty, patent infringement, and limitation of liability.

TI warrants performance of its semiconductor products to the specifications applicable at the time of sale in accordance with TI's standard warranty. Testing and other quality control techniques are utilized to the extent TI deems necessary to support this warranty. Specific testing of all parameters of each device is not necessarily performed, except those mandated by government requirements.

CERTAIN APPLICATIONS USING SEMICONDUCTOR PRODUCTS MAY INVOLVE POTENTIAL RISKS OF DEATH, PERSONAL INJURY, OR SEVERE PROPERTY OR ENVIRONMENTAL DAMAGE ("CRITICAL APPLICATIONS"). TI SEMICONDUCTOR PRODUCTS ARE NOT DESIGNED, AUTHORIZED, OR WARRANTED TO BE SUITABLE FOR USE IN LIFE-SUPPORT DEVICES OR SYSTEMS OR OTHER CRITICAL APPLICATIONS. INCLUSION OF TI PRODUCTS IN SUCH APPLICATIONS IS UNDERSTOOD TO BE FULLY AT THE CUSTOMER'S RISK.

In order to minimize risks associated with the customer's applications, adequate design and operating safeguards must be provided by the customer to minimize inherent or procedural hazards.

TI assumes no liability for applications assistance or customer product design. TI does not warrant or represent that any license, either express or implied, is granted under any patent right, copyright, mask work right, or other intellectual property right of TI covering or relating to any combination, machine, or process in which such semiconductor products or services might be or are used. TI's publication of information regarding any third party's products or services does not constitute TI's approval, warranty or endorsement thereof.