

SN54ALS157A, SN54ALS158 SN74ALS157A, SN74ALS158, SN74AS157, SN74AS158 QUADRUPLE 1-OF-2 DATA SELECTORS/MULTIPLEXERS

SDAS081C – APRIL 1982 – REVISED DECEMBER 1994

- Buffered Inputs and Outputs
- Package Options Include Plastic Small-Outline (D) Packages, Ceramic Chip Carriers (FK), and Standard Plastic (N) and Ceramic (J) 300-mil DIPs

description

These data selectors/multiplexers contain inverters and drivers to supply full data selection to the four output gates. A separate strobe (\overline{G}) input is provided. A 4-bit word is selected from one of two sources and is routed to the four outputs. The 'ALS157A and SN74AS157 present true data. The 'ALS158 and SN74AS158 present inverted data to minimize propagation delay time.

The SN54ALS157A and SN54ALS158 are characterized for operation over the full military temperature range of -55°C to 125°C . The SN74ALS157A, SN74ALS158, SN74AS157, and SN74AS158 are characterized for operation from 0°C to 70°C .

SN54ALS157A, SN54ALS158 . . . J PACKAGE
SN74ALS157A, SN74ALS158,
SN74AS157, SN74AS158 . . . D OR N PACKAGE
(TOP VIEW)

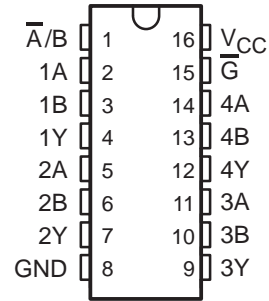

SN54ALS157A, SN54ALS158 . . . FK PACKAGE
(TOP VIEW)

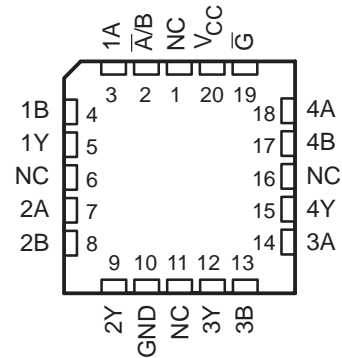

NC – No internal connection

FUNCTION TABLE

INPUTS		OUTPUT Y			
\overline{G}	$\overline{A/B}$	DATA		'ALS157A SN74AS157	'ALS158 SN74AS158
		A	B		
H	X	X	X	L	H
L	L	L	X	L	H
L	L	H	X	H	L
L	H	X	L	L	H
L	H	X	H	H	L

SN54ALS157A, SN54ALS158
SN74ALS157A, SN74ALS158, SN74AS157, SN74AS158
QUAD 1-OF-2 DATA SELECTORS/MULTIPLEXERS

SDAS081C – APRIL 1982 – REVISED DECEMBER 1994

logic symbols†

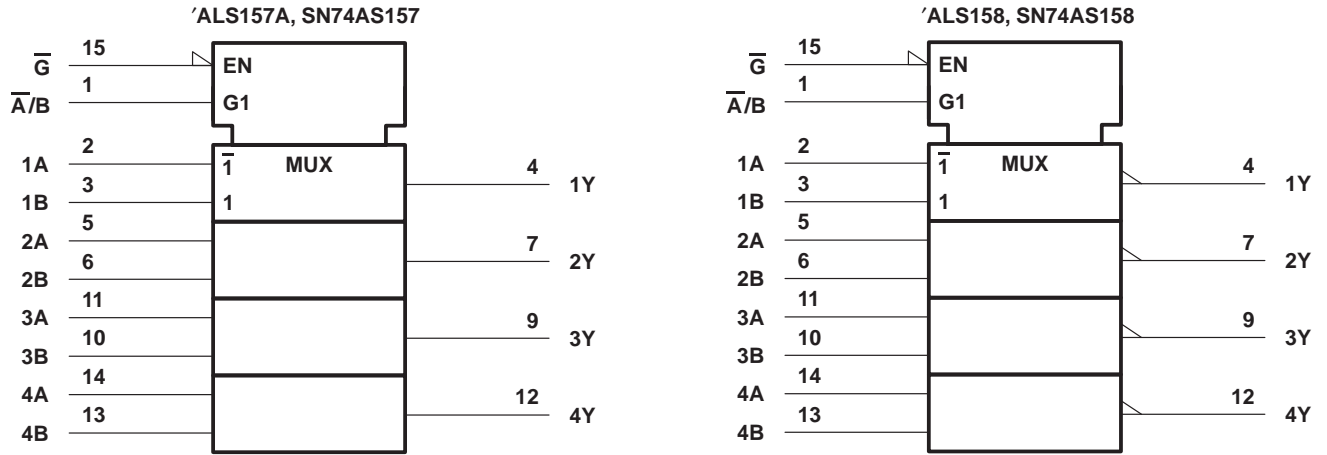

† These symbols are in accordance with ANSI/IEEE Std 91-1984 and IEC Publication 617-12. Pin numbers shown are for the D, J, and N packages.

SN54ALS157A, SN54ALS158
SN74ALS157A, SN74ALS158, SN74AS157, SN74AS158
QUAD 1-OF-2 DATA SELECTORS/MULTIPLEXERS

SDAS081C - APRIL 1982 - REVISED DECEMBER 1994

logic diagrams (positive logic)

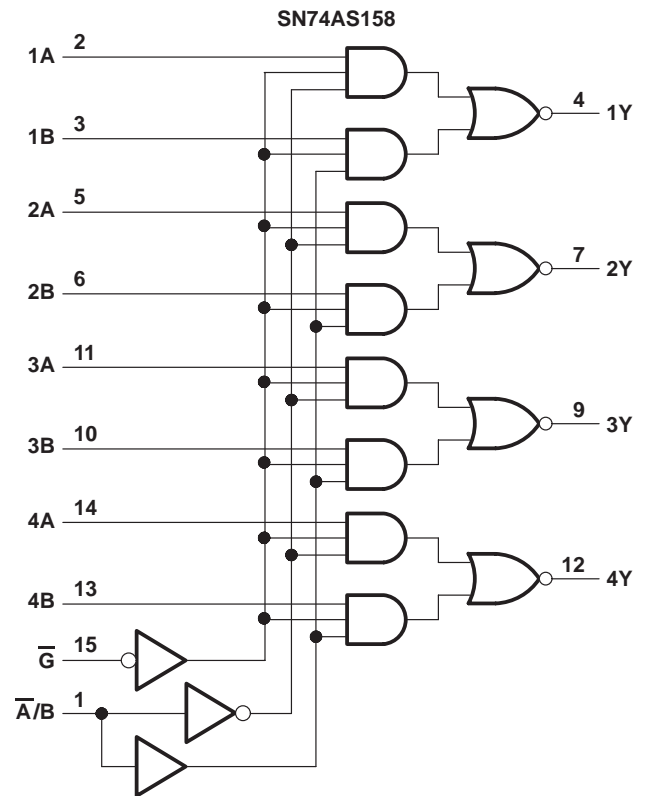
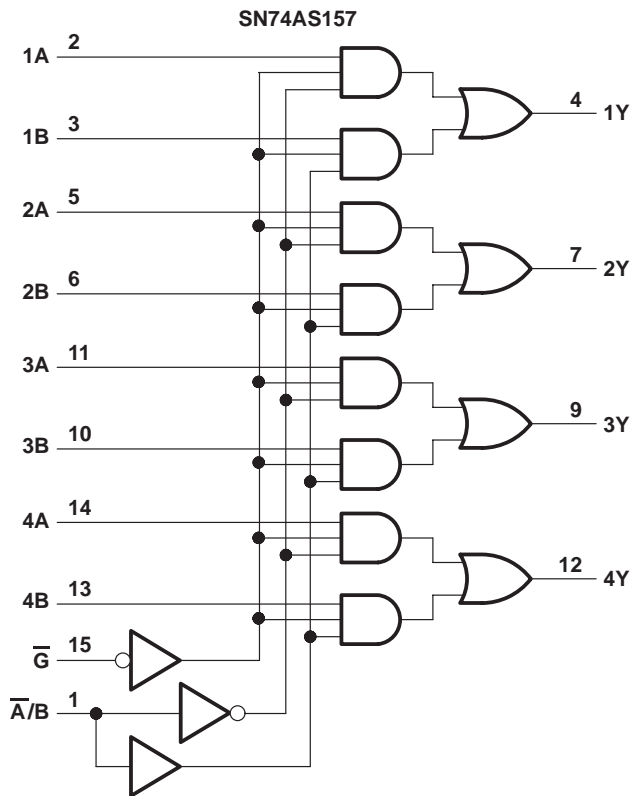
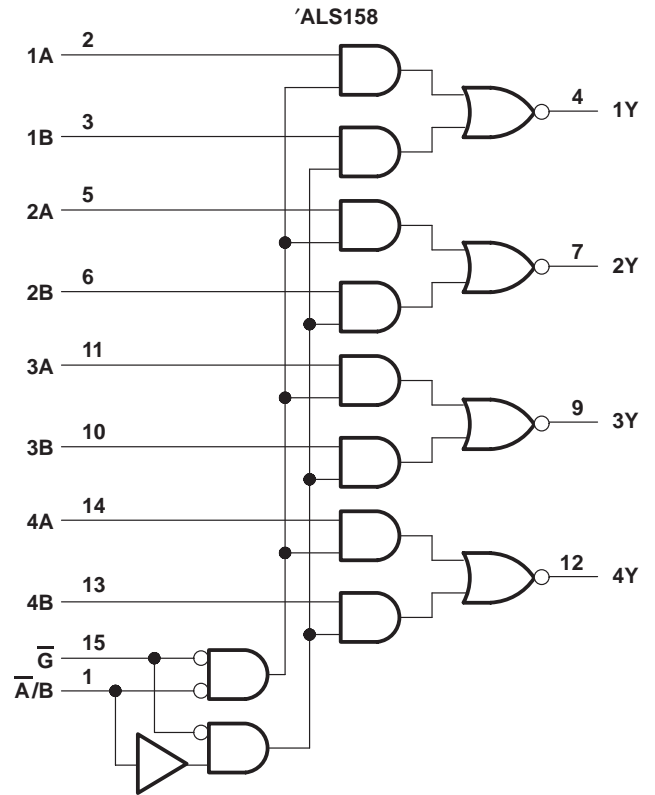
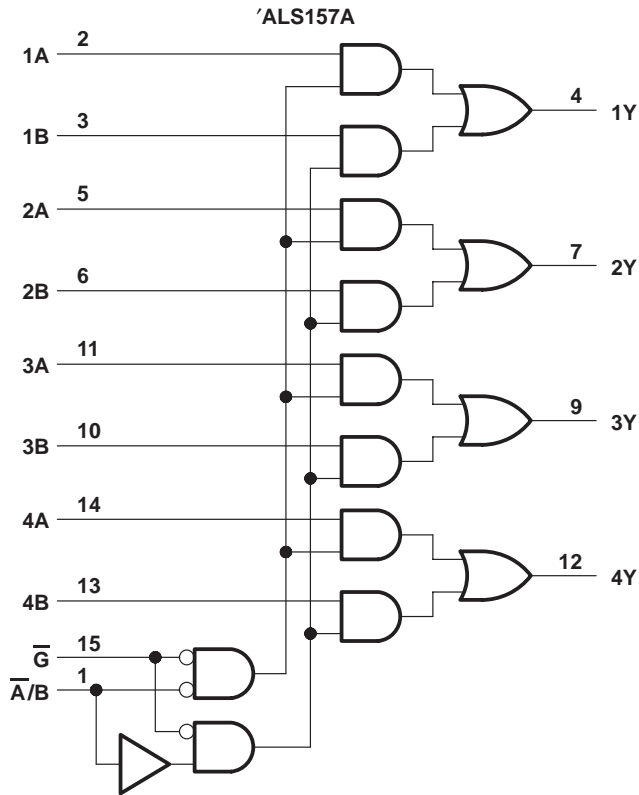

Pin numbers shown are for the D, J, and N packages.

SN54ALS157A, SN54ALS158
SN74ALS157A, SN74ALS158, SN74AS157, SN74AS158
QUAD 1-OF-2 DATA SELECTORS/MULTIPLEXERS

SDAS081C – APRIL 1982 – REVISED DECEMBER 1994

absolute maximum ratings over operating free-air temperature range (unless otherwise noted)†

Supply voltage, V_{CC}	7 V
Input voltage, V_I	7 V
Operating free-air temperature range, T_A : SN54ALS157A, SN54ALS158	-55°C to 125°C
SN74ALS157A, SN74ALS158	0°C to 70°C
Storage temperature range	-65°C to 150°C

† Stresses beyond those listed under “absolute maximum ratings” may cause permanent damage to the device. These are stress ratings only, and functional operation of the device at these or any other conditions beyond those indicated under “recommended operating conditions” is not implied. Exposure to absolute-maximum-rated conditions for extended periods may affect device reliability.

recommended operating conditions

		SN54ALS157A SN54ALS158			SN74ALS157A SN74ALS158			UNIT
		MIN	NOM	MAX	MIN	NOM	MAX	
V_{CC}	Supply voltage	4.5	5	5.5	4.5	5	5.5	V
V_{IH}	High-level input voltage	2			2			V
V_{IL}	Low-level input voltage			0.7			0.8	V
I_{OH}	High-level output current			-0.4			-0.4	mA
I_{OL}	Low-level output current			4			8	mA
T_A	Operating free-air temperature	-55		125	0		70	°C

electrical characteristics over recommended operating free-air temperature range (unless otherwise noted)

PARAMETER	TEST CONDITIONS	SN54ALS157A SN54ALS158			SN74ALS157A SN74ALS158			UNIT
		MIN	TYP‡	MAX	MIN	TYP‡	MAX	
V_{IK}	$V_{CC} = 4.5 V$, $I_I = -18 mA$			-1.2			-1.2	V
V_{OH}	$V_{CC} = 4.5 V$ to $5.5 V$, $I_{OH} = -0.4 mA$	$V_{CC} - 2$			$V_{CC} - 2$			V
V_{OL}	$V_{CC} = 4.5 V$		0.25	0.4		0.25	0.4	V
		$I_{OL} = 4 mA$				0.35	0.5	
I_I	$V_{CC} = 5.5 V$, $V_I = 7 V$			0.1			0.1	mA
I_{IH}	$V_{CC} = 5.5 V$, $V_I = 2.7 V$			20			20	μA
I_{IL}	$V_{CC} = 5.5 V$, $V_I = 0.4 V$			-0.1			-0.1	mA
I_O^{\S}	$V_{CC} = 5.5 V$, $V_O = 2.25 V$	-20		-112	-30		-112	mA
I_{CC}	'ALS157A	$V_{CC} = 5.5 V$, See Note 1	6	11	6	11	mA	
	'ALS158		5	10	5	10		

‡ All typical values are at $V_{CC} = 5 V$, $T_A = 25^\circ C$.

§ The output conditions have been chosen to produce a current that closely approximates one half of the true short-circuit output current, I_{OS} .

NOTE 1: I_{CC} is measured with 4.5 V applied to all inputs and all outputs open.



SN54ALS157A, SN54ALS158
SN74ALS157A, SN74ALS158, SN74ALS157, SN74ALS158
QUAD 1-OF-2 DATA SELECTORS/MULTIPLEXERS

SDAS081C – APRIL 1982 – REVISED DECEMBER 1994

switching characteristics (see Figure 1)

PARAMETER	FROM (INPUT)	TO (OUTPUT)	$V_{CC} = 5\text{ V}$, $C_L = 50\text{ pF}$, $R_L = 500\ \Omega$, $T_A = 25^\circ\text{C}$	$V_{CC} = 4.5\text{ V to }5.5\text{ V}$, $C_L = 50\text{ pF}$, $R_L = 500\ \Omega$, $T_A = \text{MIN to MAX}^\dagger$				UNIT
			'ALS157A	SN54ALS157A		SN74ALS157A		
			TYP	MIN	MAX	MIN	MAX	
t_{PLH}	A or B	Y	9	4	17	4	14	ns
t_{PHL}			6	2	15	2	12	
t_{PLH}	\bar{A}/B	Y	15	7	28	7	24	ns
t_{PHL}			9	4	20	4	17	
t_{PLH}	\bar{G}	Y	14	7	25	7	20	ns
t_{PHL}			10	4	18	4	13	

† For conditions shown as MIN or MAX, use the appropriate value specified under recommended operating conditions.

switching characteristics (see Figure 1)

PARAMETER	FROM (INPUT)	TO (OUTPUT)	$V_{CC} = 5\text{ V}$, $C_L = 50\text{ pF}$, $R_L = 500\ \Omega$, $T_A = 25^\circ\text{C}$	$V_{CC} = 4.5\text{ V to }5.5\text{ V}$, $C_L = 50\text{ pF}$, $R_L = 500\ \Omega$, $T_A = \text{MIN to MAX}^\dagger$				UNIT
			'ALS158	SN54ALS158		SN74ALS158		
			TYP	MIN	MAX	MIN	MAX	
t_{PLH}	A or B	Y	9	4	18	4	15	ns
t_{PHL}			5	2	12	2	8	
t_{PLH}	\bar{A}/B	Y	13	5	22	5	18	ns
t_{PHL}			13	5	22	5	18	
t_{PLH}	\bar{G}	Y	13	5	22	5	18	ns
t_{PHL}			13	5	22	5	18	

† For conditions shown as MIN or MAX, use the appropriate value specified under recommended operating conditions.

SN54ALS157A, SN54ALS158
SN74ALS157A, SN74ALS158, SN74AS157, SN74AS158
QUAD 1-OF-2 DATA SELECTORS/MULTIPLEXERS

SDAS081C – APRIL 1982 – REVISED DECEMBER 1994

absolute maximum ratings over operating free-air temperature range (unless otherwise noted)†

Supply voltage, V_{CC}	7 V
Input voltage, V_I	7 V
Operating free-air temperature range, T_A : SN74AS157, SN74AS158	0°C to 70°C
Storage temperature range	-65°C to 150°C

† Stresses beyond those listed under “absolute maximum ratings” may cause permanent damage to the device. These are stress ratings only, and functional operation of the device at these or any other conditions beyond those indicated under “recommended operating conditions” is not implied. Exposure to absolute-maximum-rated conditions for extended periods may affect device reliability.

recommended operating conditions

		SN74AS157 SN74AS158			UNIT
		MIN	NOM	MAX	
V_{CC}	Supply voltage	4.5	5	5.5	V
V_{IH}	High-level input voltage	2			V
V_{IL}	Low-level input voltage			0.8	V
I_{OH}	High-level output current			-2	mA
I_{OL}	Low-level output current			20	mA
T_A	Operating free-air temperature	0		70	°C

electrical characteristics over recommended operating free-air temperature range (unless otherwise noted)

PARAMETER	TEST CONDITIONS	SN74AS157 SN74AS158			UNIT
		MIN	TYP‡	MAX	
V_{IK}	$V_{CC} = 4.5\text{ V}$, $I_I = -18\text{ mA}$			-1.2	V
V_{OH}	$V_{CC} = 4.5\text{ V to } 5.5\text{ V}$, $I_{OH} = -2\text{ mA}$	$V_{CC} - 2$			V
V_{OL}	$V_{CC} = 4.5\text{ V}$, $I_{OL} = 20\text{ mA}$		0.35	0.5	V
I_I	\bar{A}/B	$V_{CC} = 5.5\text{ V}$, $V_I = 7\text{ V}$		0.2	mA
	A, B, or \bar{G}			0.1	
I_{IH}	\bar{A}/B	$V_{CC} = 5.5\text{ V}$, $V_I = 2.7\text{ V}$		40	μA
	A, B, or \bar{G}			20	
I_{IL}	\bar{A}/B	$V_{CC} = 5.5\text{ V}$, $V_I = 0.4\text{ V}$		-1	mA
	A, B, or \bar{G}			-0.5	
$I_{O\S}$	$V_{CC} = 5.5\text{ V}$, $V_O = 2.25\text{ V}$	-30		-112	mA
I_{CC}	SN74AS157	$V_{CC} = 5.5\text{ V}$		17.5	mA
	SN74AS158			15.6	

‡ All typical values are at $V_{CC} = 5\text{ V}$, $T_A = 25^\circ\text{C}$.

§ The output conditions have been chosen to produce a current that closely approximates one half of the true short-circuit output current, I_{OS} .



SN54ALS157A, SN54ALS158
SN74ALS157A, SN74ALS158, SN74AS157, SN74AS158
QUAD 1-OF-2 DATA SELECTORS/MULTIPLEXERS

SDAS081C – APRIL 1982 – REVISED DECEMBER 1994

switching characteristics (see Figure 1)

PARAMETER	FROM (INPUT)	TO (OUTPUT)	V _{CC} = 4.5 V to 5.5 V, C _L = 50 pF, R _L = 500 Ω, T _A = MIN to MAX†		UNIT
			SN74AS157		
			MIN	MAX	
t _{PLH}	A or B	Y	1	6	ns
t _{PHL}			1	5.5	
t _{PLH}	\bar{A}/B	Y	2	11	ns
t _{PHL}			2	10	
t _{PLH}	\bar{G}	Y	2	10.5	ns
t _{PHL}			2	7.5	

† For conditions shown as MIN or MAX, use the appropriate value specified under recommended operating conditions.

switching characteristics (see Figure 1)

PARAMETER	FROM (INPUT)	TO (OUTPUT)	V _{CC} = 4.5 V to 5.5 V, C _L = 50 pF, R _L = 500 Ω, T _A = MIN to MAX†		UNIT
			SN74AS158		
			MIN	MAX	
t _{PLH}	A or B	Y	1	5	ns
t _{PHL}			1	4.5	
t _{PLH}	\bar{A}/B	Y	2	9.5	ns
t _{PHL}			2	10.5	
t _{PLH}	\bar{G}	Y	2	6.5	ns
t _{PHL}			2	10	

† For conditions shown as MIN or MAX, use the appropriate value specified under recommended operating conditions.

SN54ALS157A, SN54ALS158
 SN74ALS157A, SN74ALS158, SN74AS157, SN74AS158
 QUAD 1-OF-2 DATA SELECTORS/MULTIPLEXERS

SDAS081C – APRIL 1982 – REVISED DECEMBER 1994

PARAMETER MEASUREMENT INFORMATION
 SERIES 54ALS/74ALS AND 54AS/74AS DEVICES

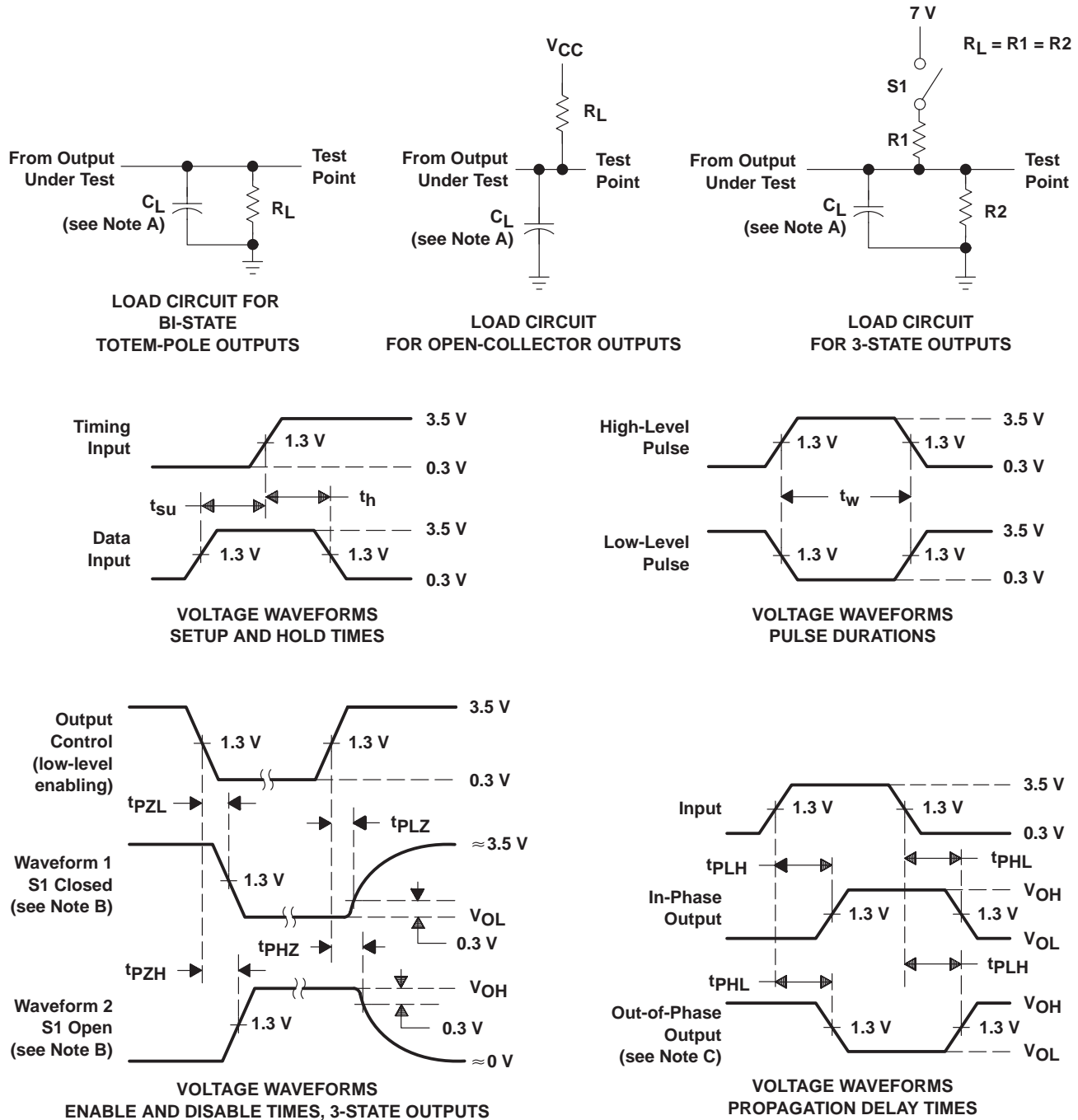

- NOTES: A. C_L includes probe and jig capacitance.
 B. Waveform 1 is for an output with internal conditions such that the output is low except when disabled by the output control. Waveform 2 is for an output with internal conditions such that the output is high except when disabled by the output control.
 C. When measuring propagation delay items of 3-state outputs, switch S1 is open.
 D. All input pulses have the following characteristics: $PRR \leq 1$ MHz, $t_r = t_f = 2$ ns, duty cycle = 50%.
 E. The outputs are measured one at a time with one transition per measurement.

Figure 1. Load Circuits and Voltage Waveforms

IMPORTANT NOTICE

Texas Instruments and its subsidiaries (TI) reserve the right to make changes to their products or to discontinue any product or service without notice, and advise customers to obtain the latest version of relevant information to verify, before placing orders, that information being relied on is current and complete. All products are sold subject to the terms and conditions of sale supplied at the time of order acknowledgement, including those pertaining to warranty, patent infringement, and limitation of liability.

TI warrants performance of its semiconductor products to the specifications applicable at the time of sale in accordance with TI's standard warranty. Testing and other quality control techniques are utilized to the extent TI deems necessary to support this warranty. Specific testing of all parameters of each device is not necessarily performed, except those mandated by government requirements.

CERTAIN APPLICATIONS USING SEMICONDUCTOR PRODUCTS MAY INVOLVE POTENTIAL RISKS OF DEATH, PERSONAL INJURY, OR SEVERE PROPERTY OR ENVIRONMENTAL DAMAGE ("CRITICAL APPLICATIONS"). TI SEMICONDUCTOR PRODUCTS ARE NOT DESIGNED, AUTHORIZED, OR WARRANTED TO BE SUITABLE FOR USE IN LIFE-SUPPORT DEVICES OR SYSTEMS OR OTHER CRITICAL APPLICATIONS. INCLUSION OF TI PRODUCTS IN SUCH APPLICATIONS IS UNDERSTOOD TO BE FULLY AT THE CUSTOMER'S RISK.

In order to minimize risks associated with the customer's applications, adequate design and operating safeguards must be provided by the customer to minimize inherent or procedural hazards.

TI assumes no liability for applications assistance or customer product design. TI does not warrant or represent that any license, either express or implied, is granted under any patent right, copyright, mask work right, or other intellectual property right of TI covering or relating to any combination, machine, or process in which such semiconductor products or services might be or are used. TI's publication of information regarding any third party's products or services does not constitute TI's approval, warranty or endorsement thereof.