



# Off-line Power Supply Controller

## FEATURES

- Transformerless Off-line Applications
- Ideal Primary-side Bias Supply
- Efficient BiCMOS Design
- Wide Input Range
- Fixed or Adjustable Low Voltage Output
- Uses Low Cost SMD Inductors
- Short Circuit Protected
- Optional Isolation Capability

## DESCRIPTION

The UCC1889 controller is optimized for use as an off-line, low power, low voltage, regulated bias supply. The unique circuit topology utilized in this device can be visualized as two cascaded flyback converters, each operating in the discontinuous mode, and both driven from a single external power switch. The significant benefit of this approach is the ability to achieve voltage conversion ratios of 400V to 12V with no transformer and low internal losses.

The control algorithm utilized by the UCC1889 is to force the switch on time to be inversely proportional to the input line voltage while the switch off time is made inversely proportional to the output voltage. This action is automatically controlled by an internal feedback loop and reference. The cascaded configuration allows a voltage conversion from 400V to 12V to be achieved with a switch duty cycle greater than 10%. This topology also offers inherent short circuit protection since as the output voltage falls to zero, the switch off time approaches infinity.

The output voltage can be easily set to 12V or 18V. Moreover, it can be programmed for other output voltages less than 18V with a few additional components. An isolated version can be achieved with this topology as described further in Unitrode Application Note U-149.

## OPERATION

With reference to the application diagram below, when input voltage is first applied, the  $R_{ON}$  current into  $T_{ON}$  is directed to  $V_{CC}$  where it charges the external capacitor,  $C_3$ , connected to  $V_{CC}$ . As voltage builds on  $V_{CC}$ , an internal undervoltage lockout holds the circuit off and the output at  $DRIVE$  low until  $V_{CC}$  reaches 8.4V. At this time,  $DRIVE$  goes high turning on the power switch,  $Q_1$ , and redirecting the current into  $T_{ON}$  to the timing capacitor,  $C_T$ .  $C_T$  charges to a fixed threshold with a current  $I_{CHG} = 0.8 \cdot (V_{IN} - 4.5V) / R_{ON}$ . Since  $DRIVE$  will only be high for as long as  $C_T$  charges, the power switch on time will be inversely proportional to line voltage. This provides a constant line voltage-switch on time product.

## TYPICAL APPLICATION

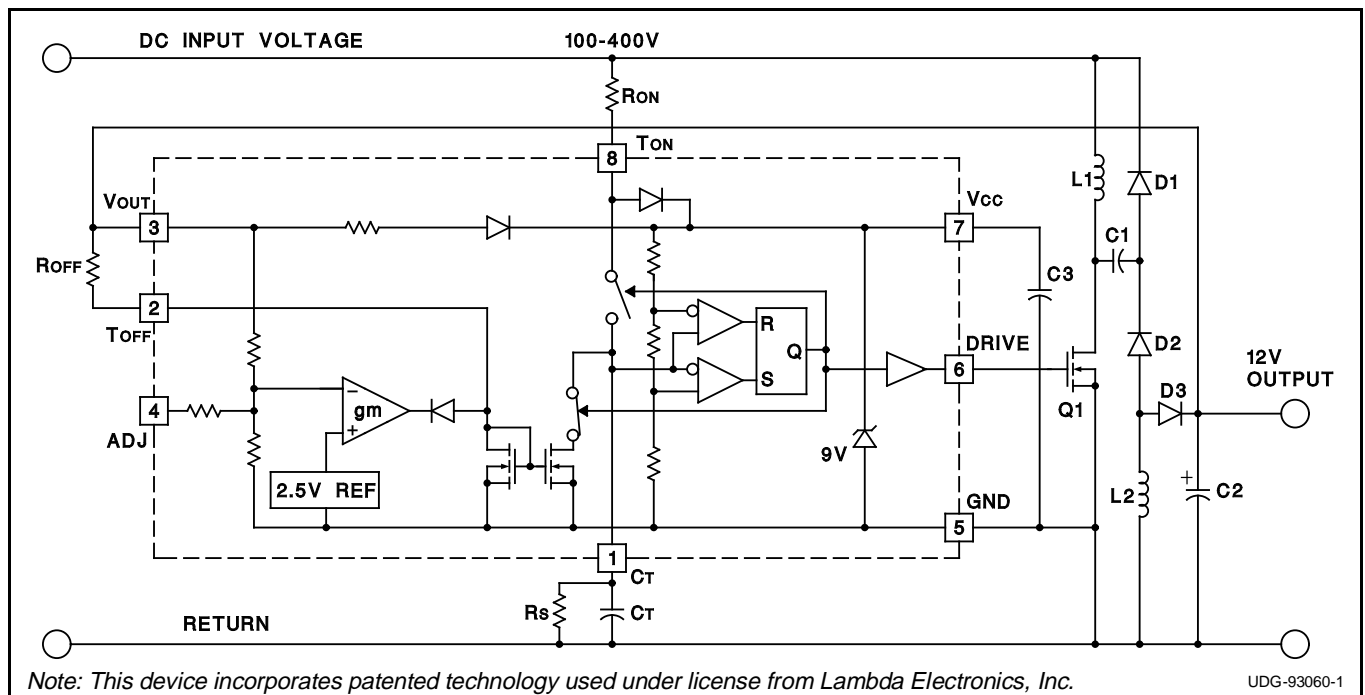

**OPERATION (cont.)**

At the end of the on time, Q1 is turned off and the RON current into TON is again diverted to VCC. Thus the current through RON, which charges CT during the on time, contributes to supplying control power during the off time.

The power switch off time is controlled by the discharge of CT which, in turn, is programmed by the regulated output voltage. The relationship between CT discharge current, IDCHG, and output voltage is illustrated as follows:

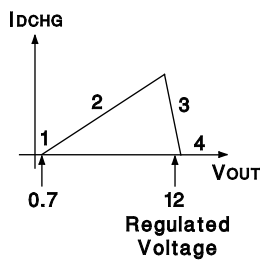

1. When VOUT = 0, the off time is infinite. This feature provides inherent short circuit protection. However, to ensure output voltage startup when the output is not a short, a high value resistor, Rs, is placed in parallel with CT to establish a minimum switching frequency.
2. As VOUT rises above approximately 0.7V to its regulated value, IDCHG is defined by ROFF, and therefore is equal to:

$$IDCHG = (VOUT - 0.7V) / ROFF$$

As VOUT increases, IDCHG increases resulting in the reduction of off time. The frequency of operation increases and VOUT rises quickly to its regulated value.

3. In this region, a transconductance amplifier reduces IDCHG in order to maintain VOUT in regulation.
4. If VOUT should rise above its regulation range, IDCHG falls to zero and the circuit returns to the minimum frequency established by Rs and CT.

The range of switching frequencies is established by RON, ROFF, Rs, and CT as follows:

$$\text{Frequency} = 1 / (TON + TOFF)$$

$$TON = RON \cdot CT \cdot 4.6 V / (VIN - 4.5V)$$

$$TOFF (\text{max}) = 1.4 \cdot Rs \cdot CT$$

Regions 1 and 4

$$TOFF = ROFF \cdot CT \cdot 3.7 V / (VOUT - 0.7V)$$

Region 2, excluding the effects of Rs which have a minimal impact on TOFF.

The above equations assume that VCC equals 9V. The voltage at TON increases from approximately 2.5V to 6.5V while CT is charging. To take this into account, VIN is adjusted by 4.5V in the calculation of TON. The voltage at TOFF is approximately 0.7V.

**DESIGN EXAMPLE**

The UCC3889 regulates a 12 volt, 1 Watt nonisolated DC output from AC inputs between 80 and 265 volts. In this example, the IC is programmed to deliver a maximum on time gate drive pulse width of 2.4 microseconds which occurs at 80 VAC. The corresponding switching frequency is approximately 100kHz at low line, and overall efficiency is approximately 50%. Additional design information is available in Unitrode Application Note U-149.

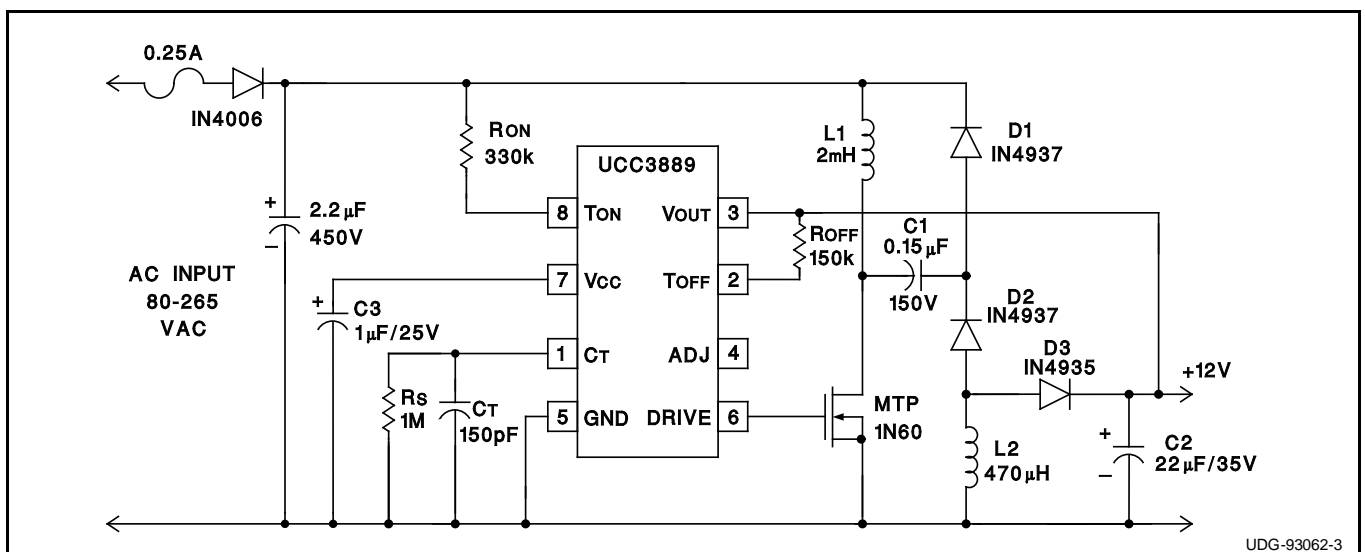

UDG-93062-3

**ABSOLUTE MAXIMUM RATINGS**

ICC..... 5mA  
 Current into TON Pin ..... 1.5mA  
 Voltage on VOUT Pin ..... 20V  
 Current into TOFF Pin ..... 250µA  
 Storage Temperature ..... -65°C to +150°C

*Note: Unless otherwise indicated, voltages are referenced to ground and currents are positive into, negative out of, the specified terminals.*

**CONNECTION DIAGRAM**

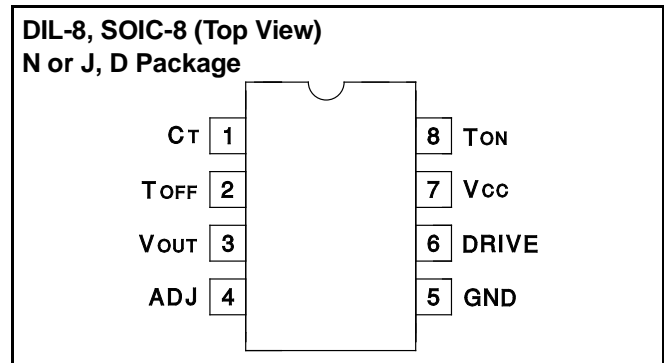

**ELECTRICAL CHARACTERISTICS** Unless otherwise stated, these specifications hold for TA = 0°C to 70°C for the UCC3889, -40°C to +85°C for the UCC2889, and -55°C to +125°C for the UCC1889. No load at DRIVE pin (CLOAD=0).

PARAMETER	TEST CONDITIONS	MIN	TYP	MAX	UNITS
<b>General</b>					
Vcc Zener Voltage	ICC < 1.5mA	8.6	9.0	9.3	V
Startup Current	VOUT = 0		150	250	µA
Operating Current I(VOUT)	VOUT = 11V, F = 150kHz		1.2	2.5	mA
<b>Under-Voltage-Lockout</b>					
Start Threshold	VOUT = 0	8.0	8.4	8.8	V
Minimum Operating Voltage after Start	VOUT = 0	6.0	6.3	6.6	V
Hysteresis	VOUT = 0	1.8			V
<b>Oscillator</b>					
Amplitude	VCC = 9V	3.5	3.7	3.9	V
CT to DRIVE high Propagation Delay	Overdrive = 0.2V		100	200	ns
CT to DRIVE low Propagation Delay	Overdrive = 0.2V		50	100	ns
<b>Driver</b>					
VOL	I = 20mA, Vcc = 9V		0.15	0.4	V
	I = 100mA, Vcc = 9V		0.7	1.8	V
VOH	I = -20mA, Vcc = 9V	8.5	8.8		V
	I = -100mA, Vcc = 9V	6.1	7.8		V
Rise Time	CLOAD = 1nF		35	70	ns
Fall Time	CLOAD = 1nF		30	60	ns
<b>Line Voltage Detection</b>					
Charge Coefficient: ICHG / I(TON)	VCT = 3V, DRIVE = High, I(TON) = 1mA	0.73	0.79	0.85	
Minimum Line Voltage for Fault	RON = 330k	60	80	100	V
Minimum Current I(TON) for Fault	RON = 330k		220		µA
On Time During Fault	CT = 150pF, VLINE = Min - 1V		2		µs
Oscillator Restart Delay after Fault			0.5		ms
<b>Vout Error Amp</b>					
VOUT Regulated 12V (ADJ Open)	VCC = 9V, IDCHG = I(TOFF)/2	11.2	11.9	12.8	V
VOUT Regulated 18V (ADJ = 0V)	VCC = 9V, IDCHG = I(TOFF)/2	16.5	17.5	19.5	V
Discharge Ratio: IDCHG / I(TOFF)	I(TOFF) = 50µA	0.95	1.01	1.07	
Voltage at TOFF	I(TOFF) = 50µA	0.6	0.95	1.3	V
Regulation gm (Note 1)	Max IDCHG = 50µA		1.0		mA/V
	Max IDCHG = 125µA	0.8	1.7	2.9	mA/V

*Note 1: gm is defined as  $\frac{\Delta IDCHG}{\Delta VOUT}$  for the values of VOUT when VOUT is in regulation. The two points used to calculate gm are for IDCHG at 65% and 35% of its maximum value.*

**PIN DESCRIPTIONS**

**ADJ:** The ADJ pin is used to provide a 12V or an 18V regulated supply without additional external components. To select the 12V option, ADJ pin is left open. To select the 18V option, ADJ pin must be grounded. For other output voltages less than 18V, a resistor divider between VOUT, ADJ and GND is needed. Note, however, that for output voltages less than VCC, the device needs additional bootstrapping to VCC from an external source such as the line voltage. If so, precautions must be taken to ensure that total ICC does not exceed 5mA.

**CT (timing capacitor):** The signal voltage across CT has a peak-to-peak swing of 3.7V for 9V VCC. As the voltage on CT crosses the oscillator upper threshold, DRIVE goes low. As the voltage on CT crosses the oscillator lower threshold, DRIVE goes high.

**DRIVE:** This output is a CMOS stage capable of sinking 200mA peak and sourcing 150mA peak. The output voltage swing is 0 to VCC.

**GND (chip ground):** All voltages are measured with respect to GND.

**TOFF (regulated output control):** TOFF sets the discharge current of the timing capacitor through an external

resistor connected between VOUT and TOFF.

**TON (line voltage control):** TON serves three functions. When CT is discharging (off time), the current through TON is routed to VCC. When CT is charging (on time), the current through TON is split 80% to set the CT charge time and 20% to sense minimum line voltage which occurs for a TON current of 220µA. For a minimum line voltage of 80V, RON is 330kΩ.

The CT voltage slightly affects the value of the charge current during the on time. During this time, the voltage at the TON pin increases from approximately 2.5V to 6.5V.

**VCC (chip supply voltage):** The supply voltage of the device at pin VCC is internally clamped at 9V. Normally, VCC is not directly powered from an external voltage source such as the line voltage. In the event that VCC is directly connected to a voltage source for additional bootstrapping, precautions must be taken to ensure that total ICC does not exceed 5mA.

**VOUT (regulated output):** The VOUT pin is directly connected to the power supply output voltage. When VOUT is greater than VCC, VOUT bootstraps VCC.

**BLOCK DIAGRAM**

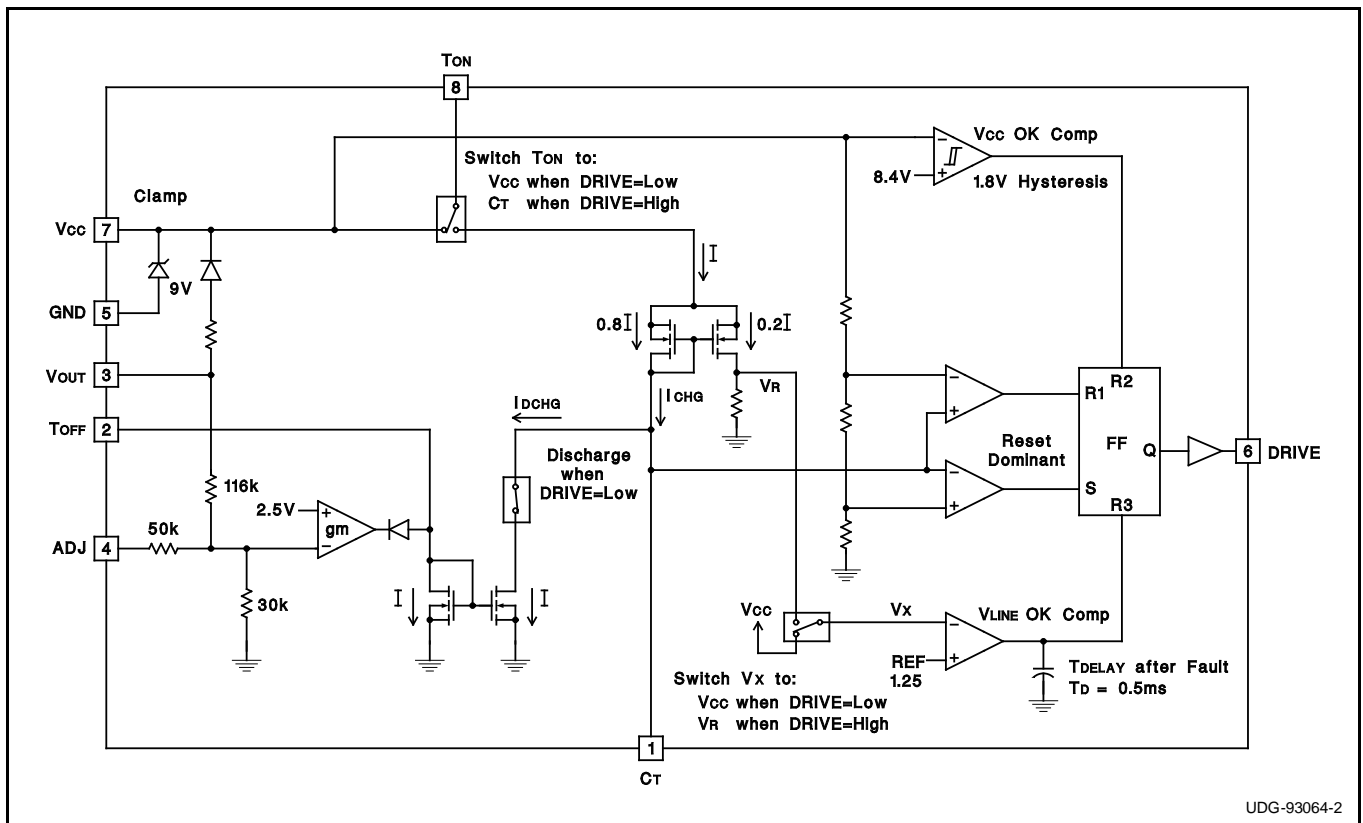

TYPICAL WAVEFORMS

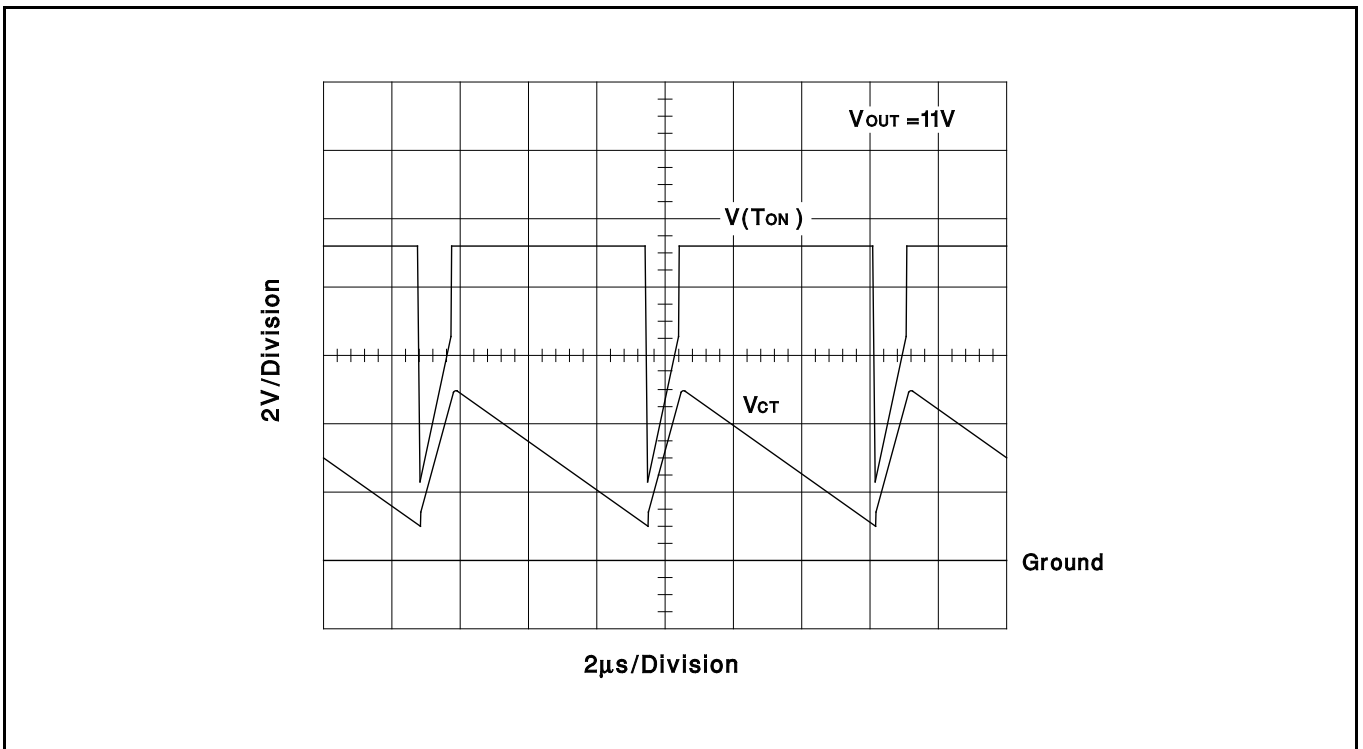
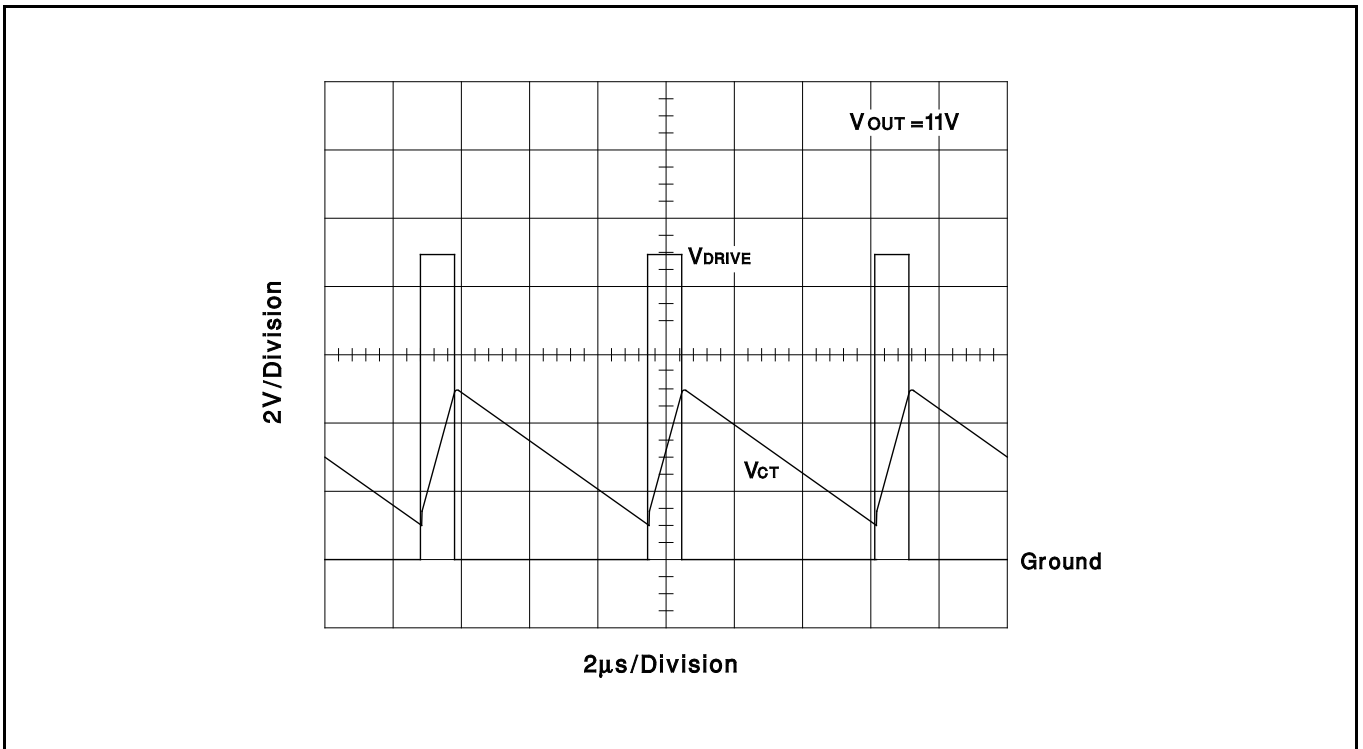

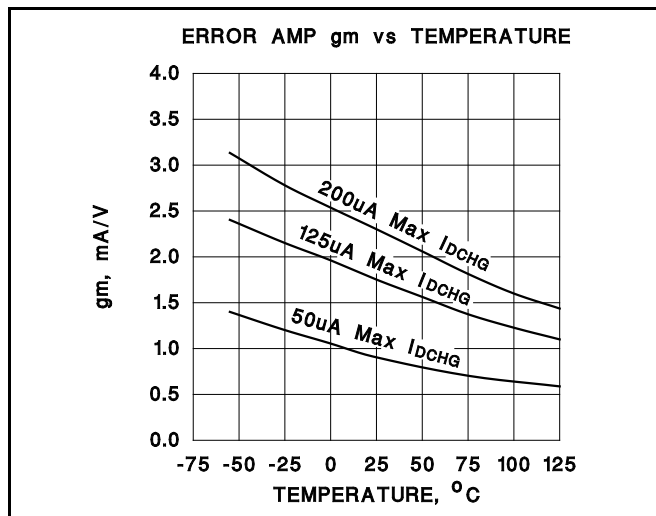
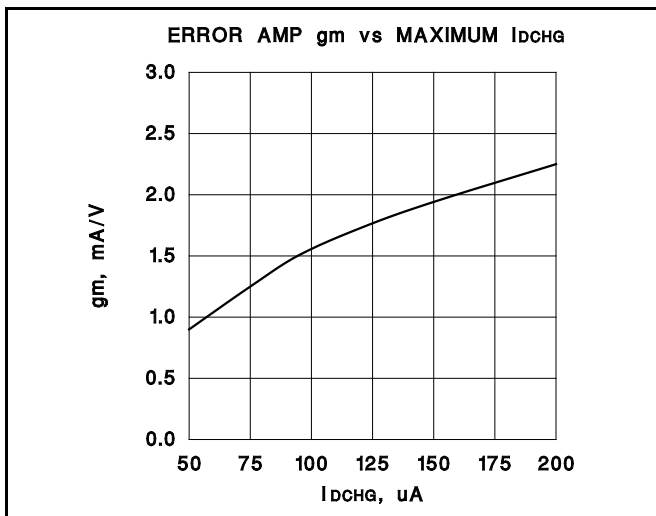
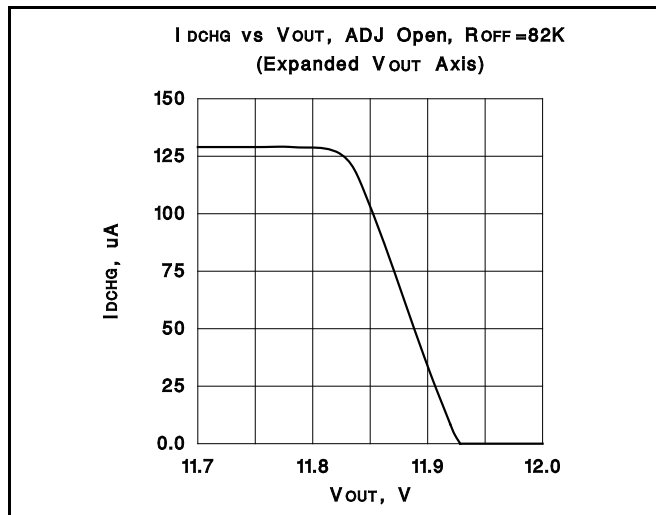
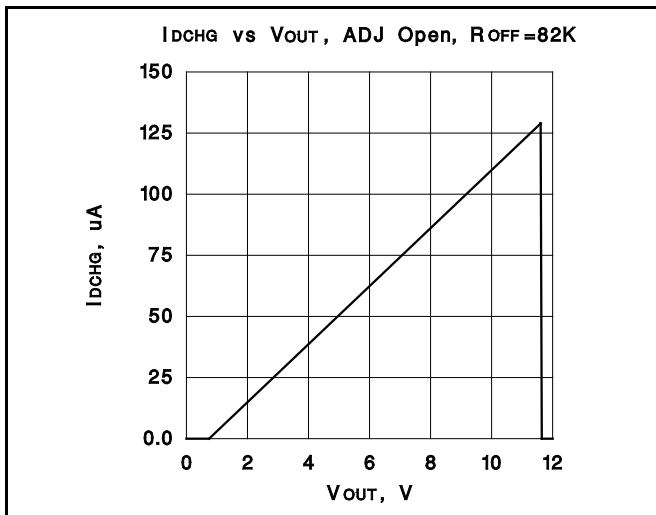
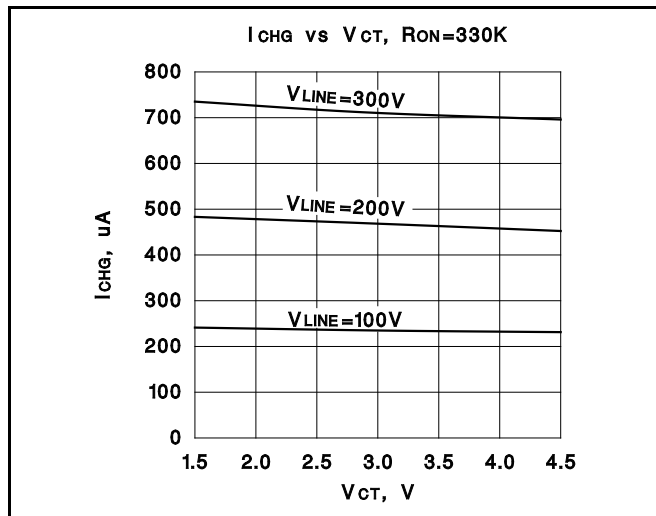
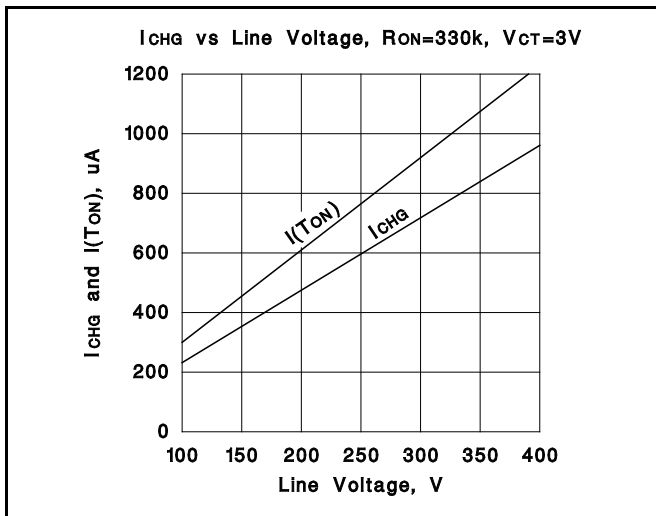

## **IMPORTANT NOTICE**

Texas Instruments and its subsidiaries (TI) reserve the right to make changes to their products or to discontinue any product or service without notice, and advise customers to obtain the latest version of relevant information to verify, before placing orders, that information being relied on is current and complete. All products are sold subject to the terms and conditions of sale supplied at the time of order acknowledgement, including those pertaining to warranty, patent infringement, and limitation of liability.

TI warrants performance of its semiconductor products to the specifications applicable at the time of sale in accordance with TI's standard warranty. Testing and other quality control techniques are utilized to the extent TI deems necessary to support this warranty. Specific testing of all parameters of each device is not necessarily performed, except those mandated by government requirements.

CERTAIN APPLICATIONS USING SEMICONDUCTOR PRODUCTS MAY INVOLVE POTENTIAL RISKS OF DEATH, PERSONAL INJURY, OR SEVERE PROPERTY OR ENVIRONMENTAL DAMAGE ("CRITICAL APPLICATIONS"). TI SEMICONDUCTOR PRODUCTS ARE NOT DESIGNED, AUTHORIZED, OR WARRANTED TO BE SUITABLE FOR USE IN LIFE-SUPPORT DEVICES OR SYSTEMS OR OTHER CRITICAL APPLICATIONS. INCLUSION OF TI PRODUCTS IN SUCH APPLICATIONS IS UNDERSTOOD TO BE FULLY AT THE CUSTOMER'S RISK.

In order to minimize risks associated with the customer's applications, adequate design and operating safeguards must be provided by the customer to minimize inherent or procedural hazards.

TI assumes no liability for applications assistance or customer product design. TI does not warrant or represent that any license, either express or implied, is granted under any patent right, copyright, mask work right, or other intellectual property right of TI covering or relating to any combination, machine, or process in which such semiconductor products or services might be or are used. TI's publication of information regarding any third party's products or services does not constitute TI's approval, warranty or endorsement thereof.