

# Phase Locked Frequency Controller

## FEATURES

- Precision Phase Locked Frequency Control System
- Crystal Oscillator
- Programmable Reference Frequency Dividers
- Phase Detector with Absolute Frequency Steering
- Separate Divider Outputs and Phase Detector Input Pins
- Double Edge Option on the Frequency Feedback Sensing Amplifier
- Two High Current Op Amps
- 5V Reference Output

## DESCRIPTION

The UC1635 family of integrated circuits was designed for use in precision speed control of DC motors. An extension to the UC1633 line of phase locked controllers, these devices provide access to both of the digital phase detector's inputs, and include a reference frequency divider output pin. With this added flexibility, this family of controllers can be used to obtain phase synchronization of multiple motors.

A reference frequency can be generated using the device's crystal oscillator and programmable dividers. The oscillator operates using a broad range of crystals, or, can function as a buffer stage to an external frequency source.

The phase detector responds proportionally to the phase error between the detector's minus input pin and the sense amplifier output. This phase detector includes absolute frequency steering to provide maximum drive signals when any frequency error exists. This feature allows optimum start-up and lock times to be realized.

Two op-amps are included that can be configured to provide necessary loop filtering. The outputs of these op-amps will source or sink in excess of 16mA, so they can provide a low impedance control signal to driving circuits.

Additional features include a double edge option on the sense amplifier that can be used to double the loop reference frequency for increased loop bandwidths. A 5V reference output can be used to accurately set DC operating levels.

## BLOCK DIAGRAM

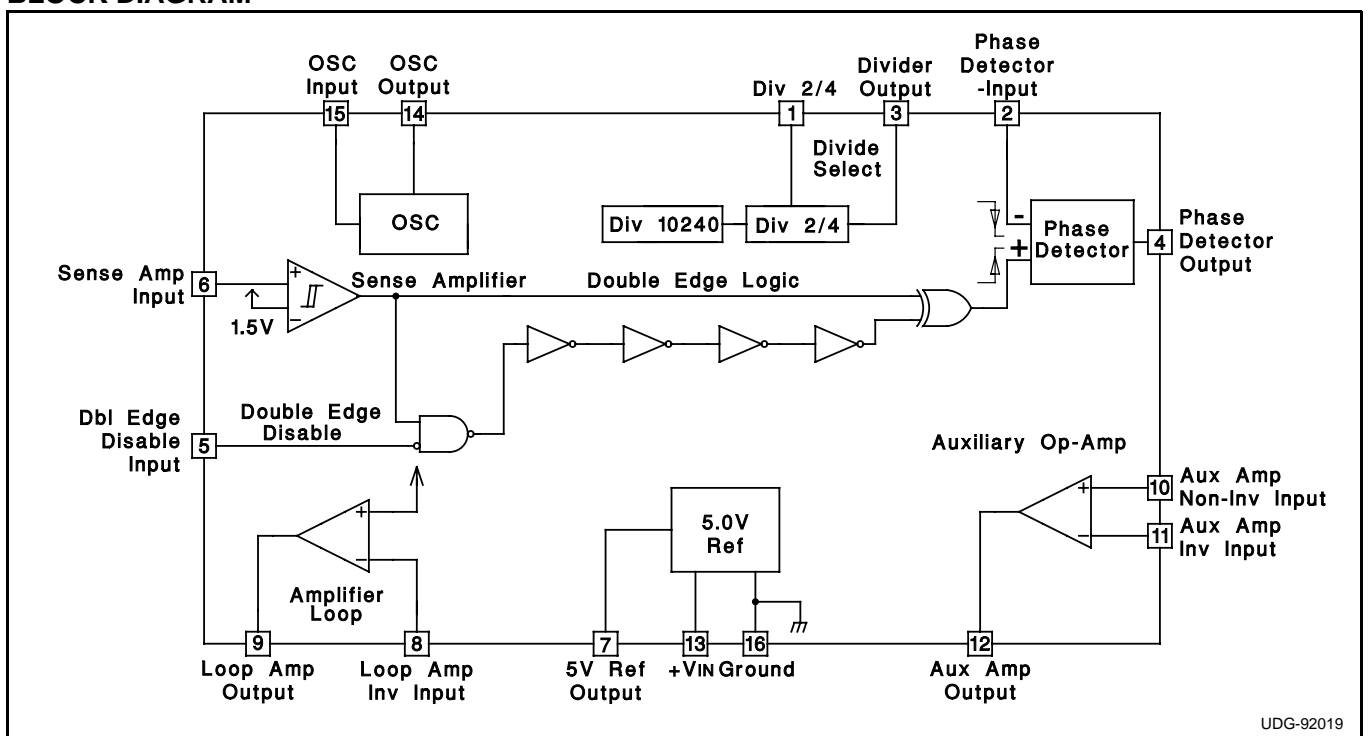

UDG-92019

### ABSOLUTE MAXIMUM RATINGS

Input Supply Voltage (+VIN)	+20V
Reference Output Current	-30mA
Op-Amp Output Currents	±30mA
Op-Amp Input Voltages	-0.3 to +20V
Phase Detector Input Voltage	-0.3V to +5V
Phase Detector Output Current	±10mA
Lock Indicator Output Current	+15mA
Lock Indicator Output Voltage	+20V
Divide Select Input Voltages	-0.3V to +10V
Double Edge Disable Input Voltage	-0.3V to +10V
Oscillator Input Voltage	-0.3V to +5V
Sense Amplifier Input Voltage	-0.3V to +20V
Power Dissipation at TA = 25°C, (Note 2)	1000mW
Power Dissipation at Tc = 25°C, (Note 2)	2000mW
Operating Junction Temperature	-55° to 150°C
Storage Temperature	-65° to +150°C
Lead Temperature (Soldering, 10 Seconds)	300°C

Note 1: Voltages are referenced to ground, (Pin 16). Currents are positive into, negative out of, the specified terminals.

Note 2: Consult Unintegrated Circuits databook for information regarding thermal specifications and limitations of packages.

### CONNECTION DIAGRAMS

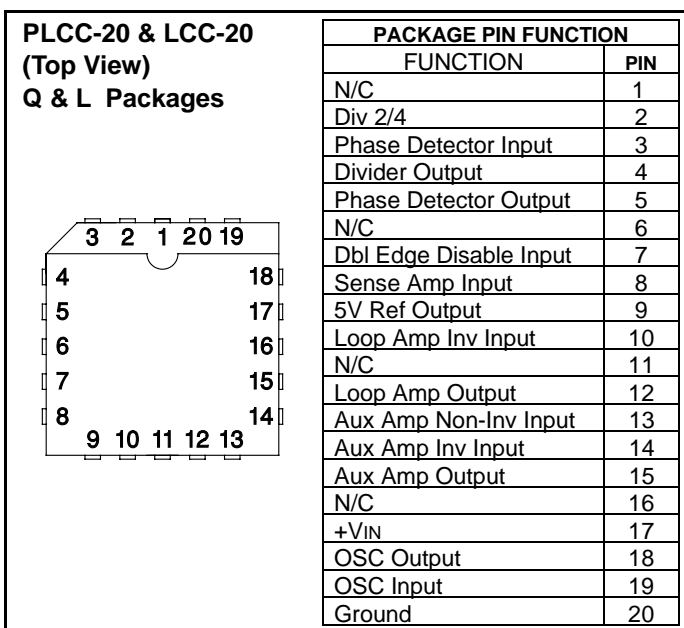
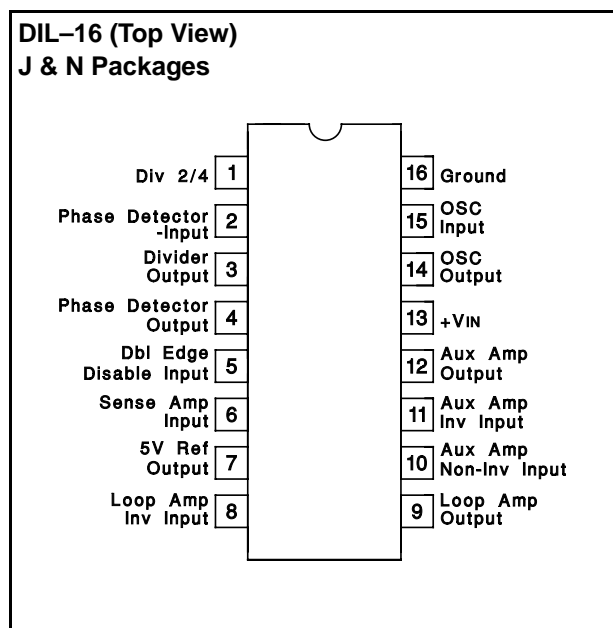
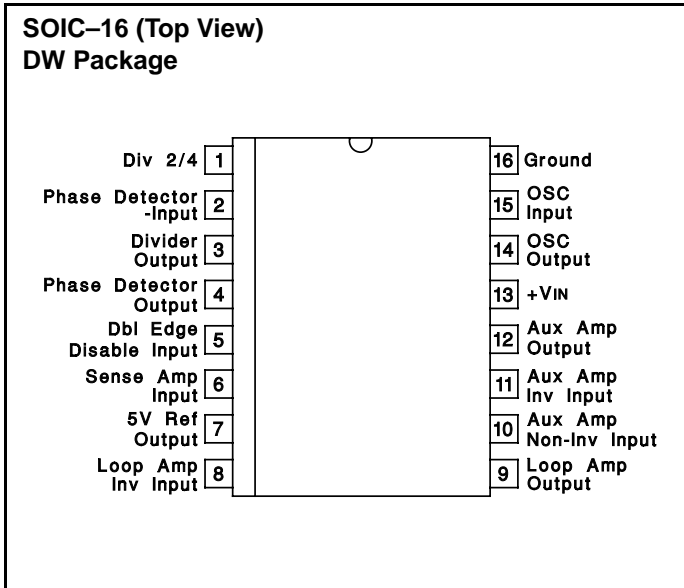

### ELECTRICAL CHARACTERISTICS:

Unless otherwise stated, specifications hold for TA = 0°C to +70°C for the UC3635, -25°C to +85°C for the UC2635 and -55°C to +125°C for the UC1635, +VIN = 12V. TA = TJ.

PARAMETER	TEST CONDITIONS	MIN	TYP	MAX	UNITS
Supply Current	+VIN = 15V		20	28	mA
<b>Reference</b>					
Output Voltage (VREF)		4.75	5.0	5.25	V
Load Regulation	IOUT = 0 to 7mA		5.0	20	mV
Line Regulation	+VIN = 8 to 15V		2.0	20	mV
Short Circuit Current	VOUT = 0V	15	35		mA

**ELECTRICAL CHARACTERISTICS:** Unless otherwise stated, specifications hold for  $T_A = 0^\circ\text{C}$  to  $+70^\circ\text{C}$  for the UC3635,  $-25^\circ\text{C}$  to  $+85^\circ\text{C}$  for the UC2635 and  $-55^\circ\text{C}$  to  $+125^\circ\text{C}$  for the UC1635,  $+V_{IN} = 12\text{V}$ .  $T_A = T_J$ .

PARAMETER	TEST CONDITIONS	MIN	TYP	MAX	UNITS
<b>Oscillator</b>					
DC Voltage Gain	Oscillator Input to Oscillator Output	12	16	20	dB
Input DC Level ( $V_{IB}$ )	Oscillator Input Pin Open, $T_J = 25^\circ\text{C}$	1.15	1.3	1.45	V
Input Impedance (Note 2)	$V_{IN} = V_{IB} \pm 0.5\text{V}$ , $T_J = 25^\circ\text{C}$	1.3	1.6	1.9	$\text{k}\Omega$
Output DC Level	Oscillator Input Pin Open, $T_J = 25^\circ\text{C}$	1.2	1.4	1.6	V
Maximum Operating Frequency		10			MHz
<b>Dividers</b>					
Maximum Input Frequency	Input = 1Vpp at Oscillator Input	10			MHz
Div 2/4 Input Current	Input = 5V (Div. by 2)		150	500	$\mu\text{A}$
	Input = 0V (Div. by 4)	-5.0	0.0	5.0	$\mu\text{A}$
Div 2/4 Threshold		0.5	1.6	2.2	V
Divider Output	High Level (w/6.8k Load to GND)	4.0	4.5		V
	Low Level (Open Collector Leakage)			10	$\mu\text{A}$
<b>Sense Amplifier</b>					
Threshold Voltage	Percent of $V_{REF}$	27	30	33	%
Threshold Hysteresis			10		mV
Input Bias Current	Input = 1.5V	-1.0	-0.2		$\mu\text{A}$
<b>Double Edge Disable Input</b>					
Input Current	Input = 5V (Disabled)		150	500	$\mu\text{A}$
	Input = 0V (Enabled)	-5.0	0.0	5.0	$\mu\text{A}$
Threshold Voltage		0.5	1.6	2.2	V
<b>Phase Detector</b>					
-Input Threshold	Detector Responds to Falling Edge	0.5	1.6	2.2	V
-Input Current	Input = 2.2V		100	250	$\mu\text{A}$
High Output Level	Positive Phase/Freq. Error, Volts Below $V_{REF}$		0.2	0.5	V
Low Output Level	Negative Phase/Freq. Error		0.2	0.5	V
Mid Output Level	Zero Phase/Freq. Error, Percent of $V_{REF}$	47	50	53	%
High Level Maximum Source Current	$V_{OUT} = 4.3\text{V}$	2.0	8.0		mA
Low Level Maximum Sink Current	$V_{OUT} = 0.7\text{V}$	2.0	5.0		mA
Mid Level Output Impedance (Note 3)	$I_{OUT} = -200$ to $+200\mu\text{A}$ , $T_J = 25^\circ\text{C}$	4.5	6.0	7.5	$\text{k}\Omega$
<b>Loop Amplifier</b>					
Non-Inv Reference Voltage	Percent of $V_{REF}$	47	50	53	%
Input Bias Current	Input = 2.5V	-0.8	-0.2		$\mu\text{A}$
AVOL		60	75		dB
PSRR	$+V_{IN} = 8$ to $15\text{V}$	70	100		dB
Short Circuit Current	Source, $V_{OUT} = 0\text{V}$	16	35		mA
	Sink, $V_{OUT} = 5\text{V}$	16	30		mA

Note 3: These impedance levels will vary with  $T_J$  at about  $1700\text{ppm}/^\circ\text{C}$ .

**ELECTRICAL CHARACTERISTICS (cont.):** Unless otherwise stated, specifications hold for  $T_A = 0^\circ\text{C}$  to  $+70^\circ\text{C}$  for the UC3635,  $-25^\circ\text{C}$  to  $+85^\circ\text{C}$  for the UC2635 and  $-55^\circ\text{C}$  to  $+125^\circ\text{C}$  for the UC1635,  $+V_{in} = 12\text{V}$ .  $T_A = T_J$ .

PARAMETER	TEST CONDITIONS	MIN	TYP	MAX	UNITS
<b>Auxiliary Op-Amp</b>					
Input Offset Voltage	$V_{CM} = 2.5\text{V}$			8	mV
Input Bias Current	$V_{CM} = 2.5\text{V}$	-0.8	-0.2		$\mu\text{A}$
Input Offset Current	$V_{CM} = 2.5\text{V}$		.01	0.1	$\mu\text{A}$
AVOL		70	120		dB
PSRR	$+V_{IN} = 8$ to $15\text{V}$	70	100		dB
CMRR	$V_{CM} = 0$ to $10\text{V}$	70	100		dB
Short Circuit Current	Source, $V_{OUT} = 0\text{V}$	16	35		mA
	Sink, $V_{OUT} = 5\text{V}$	16	30		mA

**Application and Operation Information**  
(For Additional Application Information see the UC1633 Data Sheet)  
(Pin numbers refer to DIL and SOIC packages)

**Phase Detector Input Detail**

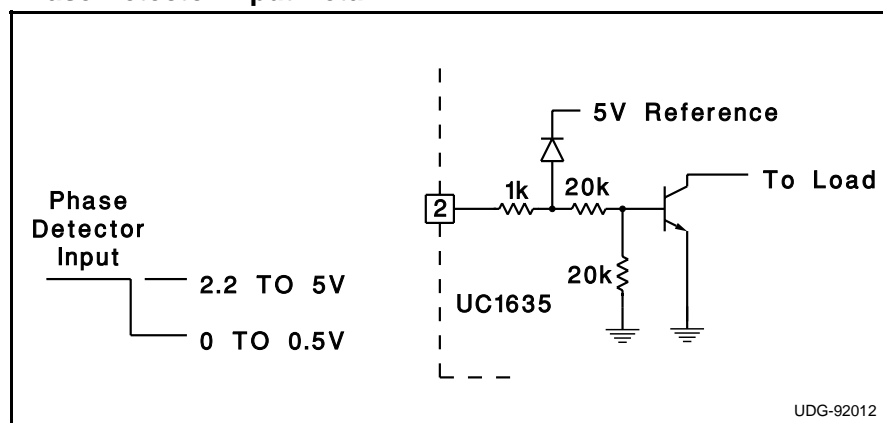

**Reference Divider Output Detail**

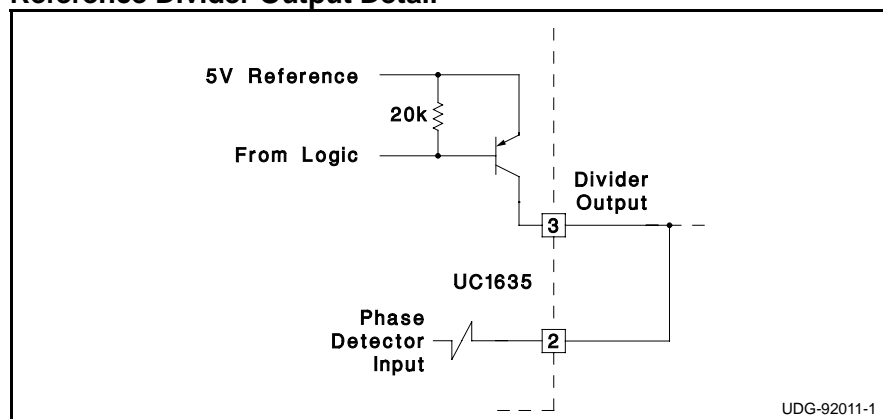

## **IMPORTANT NOTICE**

Texas Instruments and its subsidiaries (TI) reserve the right to make changes to their products or to discontinue any product or service without notice, and advise customers to obtain the latest version of relevant information to verify, before placing orders, that information being relied on is current and complete. All products are sold subject to the terms and conditions of sale supplied at the time of order acknowledgement, including those pertaining to warranty, patent infringement, and limitation of liability.

TI warrants performance of its semiconductor products to the specifications applicable at the time of sale in accordance with TI's standard warranty. Testing and other quality control techniques are utilized to the extent TI deems necessary to support this warranty. Specific testing of all parameters of each device is not necessarily performed, except those mandated by government requirements.

CERTAIN APPLICATIONS USING SEMICONDUCTOR PRODUCTS MAY INVOLVE POTENTIAL RISKS OF DEATH, PERSONAL INJURY, OR SEVERE PROPERTY OR ENVIRONMENTAL DAMAGE ("CRITICAL APPLICATIONS"). TI SEMICONDUCTOR PRODUCTS ARE NOT DESIGNED, AUTHORIZED, OR WARRANTED TO BE SUITABLE FOR USE IN LIFE-SUPPORT DEVICES OR SYSTEMS OR OTHER CRITICAL APPLICATIONS. INCLUSION OF TI PRODUCTS IN SUCH APPLICATIONS IS UNDERSTOOD TO BE FULLY AT THE CUSTOMER'S RISK.

In order to minimize risks associated with the customer's applications, adequate design and operating safeguards must be provided by the customer to minimize inherent or procedural hazards.

TI assumes no liability for applications assistance or customer product design. TI does not warrant or represent that any license, either express or implied, is granted under any patent right, copyright, mask work right, or other intellectual property right of TI covering or relating to any combination, machine, or process in which such semiconductor products or services might be or are used. TI's publication of information regarding any third party's products or services does not constitute TI's approval, warranty or endorsement thereof.