

# TPS2811, TPS2812, TPS2813, TPS2814, TPS2815 DUAL HIGH-SPEED MOSFET DRIVERS

SLVS132D – NOVEMBER 1995 – REVISED NOVEMBER 1997

- Industry-Standard Driver Replacement
- 25-ns Max Rise/Fall Times and 40-ns Max Propagation Delay – 1-nF Load,  $V_{CC} = 14\text{ V}$
- 2-A Peak Output Current,  $V_{CC} = 14\text{ V}$
- 5- $\mu\text{A}$  Supply Current — Input High or Low
- 4-V to 14-V Supply-Voltage Range; Internal Regulator Extends Range to 40 V (TPS2811, TPS2812, TPS2813)
- $-40^{\circ}\text{C}$  to  $125^{\circ}\text{C}$  Ambient-Temperature Operating Range

## description

The TPS28xx series of dual high-speed MOSFET drivers are capable of delivering peak currents of 2 A into highly capacitive loads. This performance is achieved with a design that inherently minimizes shoot-through current and consumes an order of magnitude less supply current than competitive products.

The TPS2811, TPS2812, and TPS2813 drivers include a regulator to allow operation with supply inputs between 14 V and 40 V. The regulator output can power other circuitry, provided power dissipation does not exceed package limitations. When the regulator is not required, REG\_IN and REG\_OUT can be left disconnected or both can be connected to  $V_{CC}$  or GND.

The TPS2814 and the TPS2815 have 2-input gates that give the user greater flexibility in controlling the MOSFET. The TPS2814 has AND input gates with one inverting input. The TPS2815 has dual-input NAND gates.

TPS28xx series drivers, available in 8-pin PDIP, SOIC, and TSSOP packages and as unmounted ICs, operate over a ambient temperature range of  $-40^{\circ}\text{C}$  to  $125^{\circ}\text{C}$ .

TPS2811, TPS2812, TPS2813 . . . D, P, AND PW PACKAGES (TOP VIEW)

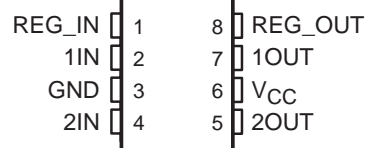

TPS2814 . . . D, P, AND PW PACKAGES (TOP VIEW)

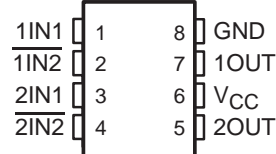

TPS2815 . . . D, P, AND PW PACKAGES (TOP VIEW)

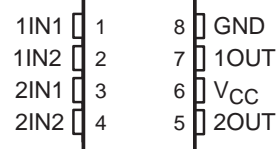

## AVAILABLE OPTIONS

T <sub>A</sub>	INTERNAL REGULATOR	LOGIC FUNCTION	PACKAGED DEVICES			CHIP FORM (Y)
			SMALL OUTLINE (D)	PLASTIC DIP (P)	TSSOP (PW)	
$-40^{\circ}\text{C}$ to $125^{\circ}\text{C}$	Yes	Dual inverting drivers Dual noninverting drivers One inverting and one noninverting driver	TPS2811D TPS2812D TPS2813D	TPS2811P TPS2812P TPS2813P	TPS2811PWLE TPS2812PWLE TPS2813PWLE	TPS2811Y TPS2812Y TPS2813Y
	No	Dual 2-input AND drivers, one inverting input on each driver Dual 2-input NAND drivers	TPS2814D TPS2815D	TPS2814P TPS2815P	TPS2814PWLE TPS2815PWLE	TPS2814Y TPS2815Y

The D package is available taped and reeled. Add R suffix to device type (e.g., TPS2811DR). The PW package is only available left-end taped and reeled and is indicated by the LE suffix on the device type (e.g., TPS2811PWLE).



Please be aware that an important notice concerning availability, standard warranty, and use in critical applications of Texas Instruments semiconductor products and disclaimers thereto appears at the end of this data sheet.

PRODUCTION DATA information is current as of publication date. Products conform to specifications per the terms of Texas Instruments standard warranty. Production processing does not necessarily include testing of all parameters.

**TEXAS  
INSTRUMENTS**

POST OFFICE BOX 655303 • DALLAS, TEXAS 75265

Copyright © 1997, Texas Instruments Incorporated

# TPS2811, TPS2812, TPS2813, TPS2814, TPS2815 DUAL HIGH-SPEED MOSFET DRIVERS

SLVS132D – NOVEMBER 1995 – REVISED NOVEMBER 1997

## functional block diagram

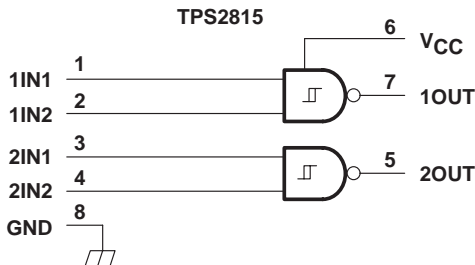
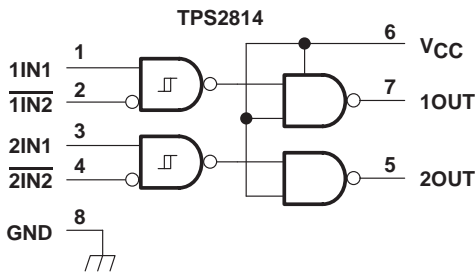
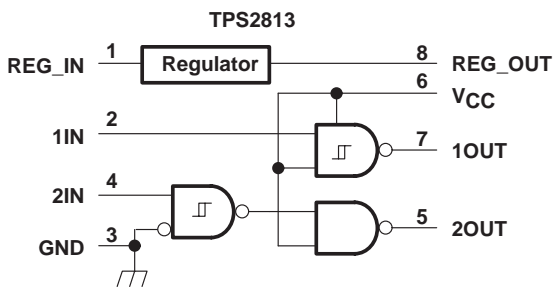
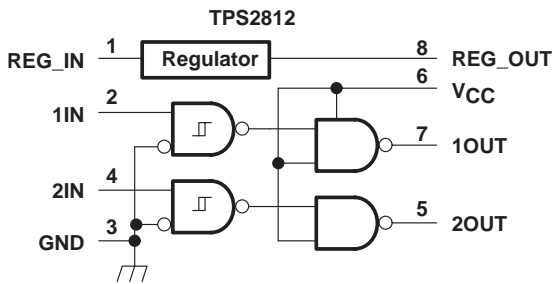
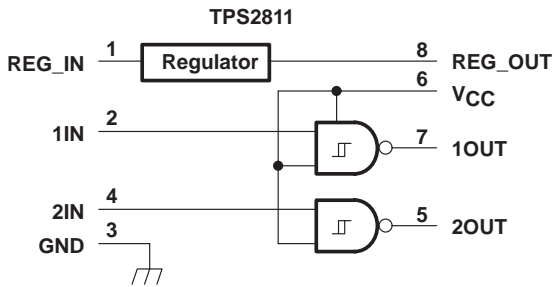

## regulator diagram (TPS2811, TPS2812, TPS2813 only)

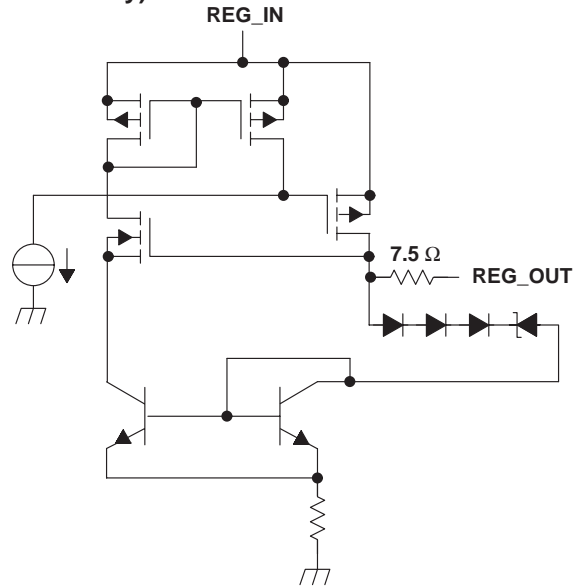

## input stage diagram

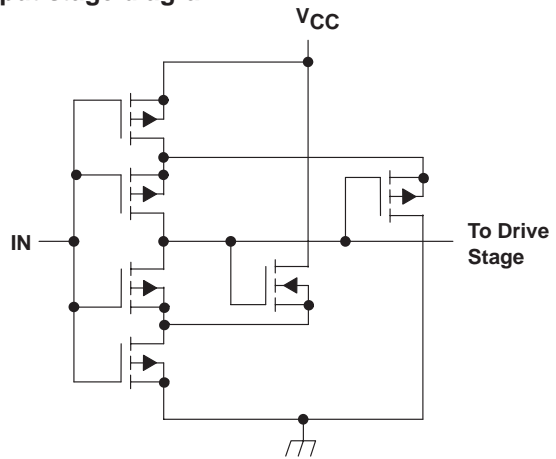

## output stage diagram

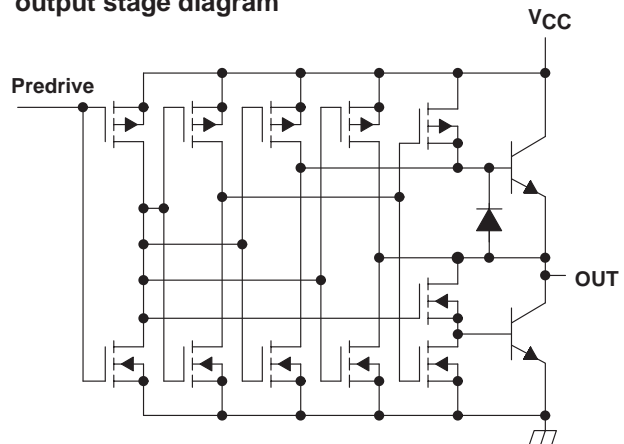

# TPS2811, TPS2812, TPS2813, TPS2814, TPS2815 DUAL HIGH-SPEED MOSFET DRIVERS

SLVS132D – NOVEMBER 1995 – REVISED NOVEMBER 1997

## TPS28xxY chip information

This chip, when properly assembled, displays characteristics similar to those of the TPS28xx. Thermal compression or ultrasonic bonding may be used on the doped aluminum bonding pads. The chip may be mounted with conductive epoxy or a gold-silicon preform.

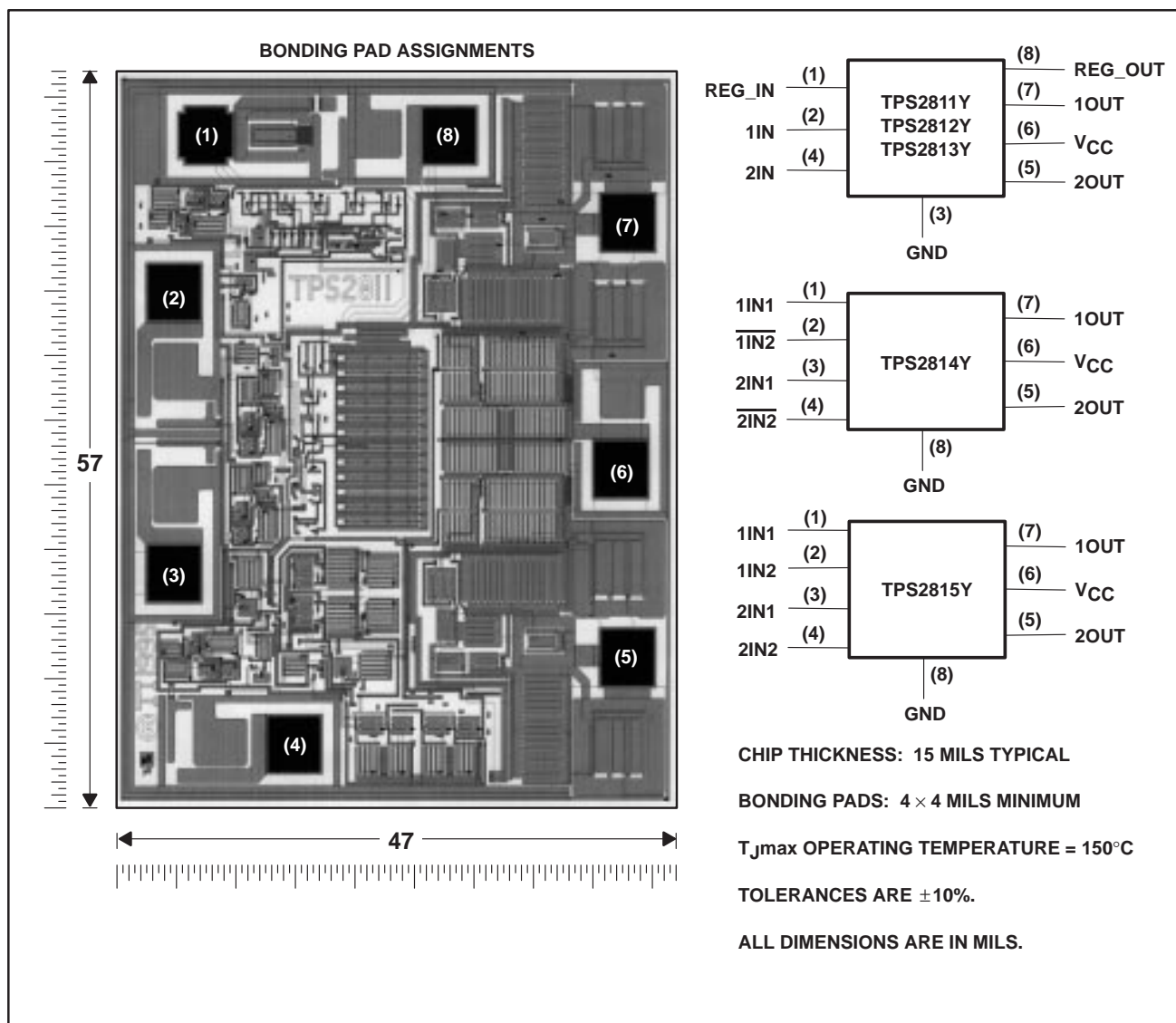

# TPS2811, TPS2812, TPS2813, TPS2814, TPS2815 DUAL HIGH-SPEED MOSFET DRIVERS

SLVS132D – NOVEMBER 1995 – REVISED NOVEMBER 1997

## Terminal Functions

### TPS2811, TPS2812, TPS2813

TERMINAL NAME	TERMINAL NUMBERS			DESCRIPTION
	TPS2811 Dual Inverting Drivers	TPS2812 Dual Noninverting Drivers	TPS2813 Complimentary Drivers	
REG_IN	1	1	1	Regulator input
1IN	2	2	2	Input 1
GND	3	3	3	Ground
2IN	4	4	4	Input 2
2OUT	5 = $\overline{2IN}$	5 = 2IN	5 = 2IN	Output 2
VCC	6	6	6	Supply voltage
1OUT	7 = $\overline{1IN}$	7 = 1IN	7 = $\overline{1IN}$	Output 1
REG_OUT	8	8	8	Regulator output

### TPS2814, TPS2815

TERMINAL NAME	TERMINAL NUMBERS		DESCRIPTION
	TPS2814 Dual AND Drivers with Single Inverting Input	TPS2815 Dual NAND Drivers	
1IN1	1	1	Noninverting input 1 of driver 1
$\overline{1IN2}$	2	-	Inverting input 2 of driver 1
1IN2	-	2	Noninverting input 2 of driver 1
2IN1	3	3	Noninverting input 1 of driver 2
$\overline{2IN2}$	4	-	Inverting input 2 of driver 2
2IN2	-	4	Noninverting input 2 of driver 2
2OUT	5 = $2IN1 \bullet \overline{2IN2}$	5 = $\overline{2IN1} \bullet 2IN2$	Output 2
VCC	6	6	Supply voltage
1OUT	7 = $1IN1 \bullet \overline{1IN2}$	7 = $\overline{1IN1} \bullet 1IN2$	Output 1
GND	8	8	Ground

DISSIPATION RATING TABLE

PACKAGE	T <sub>A</sub> ≤ 25°C POWER RATING	DERATING FACTOR ABOVE T <sub>A</sub> = 25°C	T <sub>A</sub> = 70°C POWER RATING	T <sub>A</sub> = 85°C POWER RATING
P	1090 mW	8.74 mW/°C	697 mW	566 mW
D	730 mW	5.84 mW/°C	467 mW	380 mW
PW	520 mW	4.17 mW/°C	332 mW	270 mW



POST OFFICE BOX 655303 • DALLAS, TEXAS 75265

# TPS2811, TPS2812, TPS2813, TPS2814, TPS2815 DUAL HIGH-SPEED MOSFET DRIVERS

SLVS132D – NOVEMBER 1995 – REVISED NOVEMBER 1997

## absolute maximum ratings over operating free-air temperature range (unless otherwise noted)<sup>†</sup>

Regulator input voltage range, REG_IN	–0.3 V to 42 V
Supply voltage, V <sub>CC</sub>	–0.3 V to 15 V
Input voltage range, 1IN, 2IN, 1IN1, 1IN2, $\overline{1IN2}$ , 2IN1, 2IN2, $\overline{2IN2}$	–0.3 V to V <sub>CC</sub>
Continuous regulator output current, REG_OUT	25 mA
Continuous output current, 1OUT, 2OUT	±100 mA
Continuous total power dissipation	See Dissipation Rating Table
Operating ambient temperature range, T <sub>A</sub>	–40°C to 125°C
Storage temperature range, T <sub>stg</sub>	–65°C to 150°C
Lead temperature 1,6 mm (1/16 inch) from case for 10 seconds	260°C

<sup>†</sup> Stresses beyond those listed under “absolute maximum ratings” may cause permanent damage to the device. These are stress ratings only, and functional operation of the device at these or any other conditions beyond those indicated under “recommended operating conditions” is not implied. Exposure to absolute-maximum-rated conditions for extended periods may affect device reliability.

NOTE 1: All voltages are with respect to device GND pin.

## recommended operating conditions

	MIN	MAX	UNIT
Regulator input voltage range	8	40	V
Supply voltage, V <sub>CC</sub>	4	14	V
Input voltage, 1IN1, 1IN2, $\overline{1IN2}$ , 2IN1, 2IN2, $\overline{2IN2}$ , 1IN, 2IN	–0.3	V <sub>CC</sub>	V
Continuous regulator output current, REG_OUT	0	20	mA
Ambient temperature operating range	–40	125	°C

## TPS28xx electrical characteristics over recommended operating ambient temperature range, V<sub>CC</sub> = 10 V, REG\_IN open for TPS2811/12/13, C<sub>L</sub> = 1 nF (unless otherwise noted)

### inputs

PARAMETER	TEST CONDITIONS	MIN	TYP <sup>†</sup>	MAX	UNIT
Positive-going input threshold voltage	V <sub>CC</sub> = 5 V		3.3	4	V
	V <sub>CC</sub> = 10 V		5.8	9	V
	V <sub>CC</sub> = 14 V		8.3	13	V
Negative-going input threshold voltage	V <sub>CC</sub> = 5 V	1	1.6		V
	V <sub>CC</sub> = 10 V	1	4.2		V
	V <sub>CC</sub> = 14 V	1	6.2		V
Input hysteresis	V <sub>CC</sub> = 5 V		1.6		V
Input current	Inputs = 0 V or V <sub>CC</sub>	–1	0.2	1	μA
Input capacitance			5	10	pF

<sup>†</sup> Typicals are for T<sub>A</sub> = 25°C unless otherwise noted.

### outputs

PARAMETER	TEST CONDITIONS	MIN	TYP <sup>†</sup>	MAX	UNIT
High-level output voltage	I <sub>O</sub> = –1 mA	9.75	9.9		V
	I <sub>O</sub> = –100 mA	8	9.1		
Low-level output voltage	I <sub>O</sub> = 1 mA		0.18	0.25	V
	I <sub>O</sub> = 100 mA		1	2	
Peak output current	V <sub>CC</sub> = 10 V		2		A

<sup>†</sup> Typicals are for T<sub>A</sub> = 25°C unless otherwise noted.



# TPS2811, TPS2812, TPS2813, TPS2814, TPS2815 DUAL HIGH-SPEED MOSFET DRIVERS

SLVS132D – NOVEMBER 1995 – REVISED NOVEMBER 1997

## regulator (TPS2811/2812/2813 only)

PARAMETER	TEST CONDITIONS	MIN	TYP†	MAX	UNIT
Output voltage	$14 \leq \text{REG\_IN} \leq 40 \text{ V}$ , $0 \leq I_O \leq 20 \text{ mA}$	10	11.5	13	V
Output voltage in dropout	$I_O = 10 \text{ mA}$ , $\text{REG\_IN} = 10 \text{ V}$	9	9.6		V

† Typical values are for  $T_A = 25^\circ\text{C}$  unless otherwise noted.

## supply current

PARAMETER	TEST CONDITIONS	MIN	TYP†	MAX	UNIT
Supply current into $V_{CC}$	Inputs high or low		0.2	5	$\mu\text{A}$
Supply current into $\text{REG\_IN}$	$\text{REG\_IN} = 20 \text{ V}$ , $\text{REG\_OUT}$ open		40	100	$\mu\text{A}$

† Typical values are for  $T_A = 25^\circ\text{C}$  unless otherwise noted.

## TPS28xxY electrical characteristics at $T_A = 25^\circ\text{C}$ , $V_{CC} = 10 \text{ V}$ , $\text{REG\_IN}$ open for TPS2811/12/13, $C_L = 1 \text{ nF}$ (unless otherwise noted)

### inputs

PARAMETER	TEST CONDITIONS	MIN	TYP	MAX	UNIT
Positive-going input threshold voltage	$V_{CC} = 5 \text{ V}$		3.3		V
	$V_{CC} = 10 \text{ V}$		5.8		V
	$V_{CC} = 14 \text{ V}$		8.2		V
Negative-going input threshold voltage	$V_{CC} = 5 \text{ V}$		1.6		V
	$V_{CC} = 10 \text{ V}$		3.3		V
	$V_{CC} = 14 \text{ V}$		4.2		V
Input hysteresis	$V_{CC} = 5 \text{ V}$		1.2		V
Input current	Inputs = 0 V or $V_{CC}$		0.2		$\mu\text{A}$
Input capacitance			5		pF

### outputs

PARAMETER	TEST CONDITIONS	MIN	TYP	MAX	UNIT
High-level output voltage	$I_O = -1 \text{ mA}$		9.9		V
	$I_O = -100 \text{ mA}$		9.1		
Low-level output voltage	$I_O = 1 \text{ mA}$		0.18		V
	$I_O = 100 \text{ mA}$		1		
Peak output current	$V_{CC} = 10.5 \text{ V}$		2		A

## regulator (TPS2811, 2812, 2813)

PARAMETER	TEST CONDITIONS	MIN	TYP	MAX	UNIT
Output voltage	$14 \leq \text{REG\_IN} \leq 40 \text{ V}$ , $0 \leq I_O \leq 20 \text{ mA}$		11.5		V
Output voltage in dropout	$I_O = 10 \text{ mA}$ , $\text{REG\_IN} = 10 \text{ V}$		9.6		V

## power supply current

PARAMETER	TEST CONDITIONS	MIN	TYP	MAX	UNIT
Supply current into $V_{CC}$	Inputs high or low		0.2		$\mu\text{A}$
Supply current into $\text{REG\_IN}$	$\text{REG\_IN} = 20 \text{ V}$ , $\text{REG\_OUT}$ open		40		$\mu\text{A}$



# TPS2811, TPS2812, TPS2813, TPS2814, TPS2815 DUAL HIGH-SPEED MOSFET DRIVERS

SLVS132D – NOVEMBER 1995 – REVISED NOVEMBER 1997

**switching characteristics for all devices over recommended operating ambient temperature range, REG\_IN open for TPS2811/12/13, C<sub>L</sub> = 1 nF (unless otherwise specified)**

PARAMETER		TEST CONDITIONS	MIN	TYP	MAX	UNIT
t <sub>r</sub>	Rise time	V <sub>CC</sub> = 14 V		14	25	ns
		V <sub>CC</sub> = 10 V		15	30	
		V <sub>CC</sub> = 5 V		20	35	
t <sub>f</sub>	Fall time	V <sub>CC</sub> = 14 V		15	25	ns
		V <sub>CC</sub> = 10 V		15	30	
		V <sub>CC</sub> = 5 V		18	35	
t <sub>PHL</sub>	Prop delay time high-to-low-level output	V <sub>CC</sub> = 14 V		25	40	ns
		V <sub>CC</sub> = 10 V		25	45	
		V <sub>CC</sub> = 5 V		34	50	
t <sub>PLH</sub>	Prop delay time low-to-high-level output	V <sub>CC</sub> = 14 V		24	40	ns
		V <sub>CC</sub> = 10 V		26	45	
		V <sub>CC</sub> = 5 V		36	50	

## PARAMETER MEASUREMENT INFORMATION

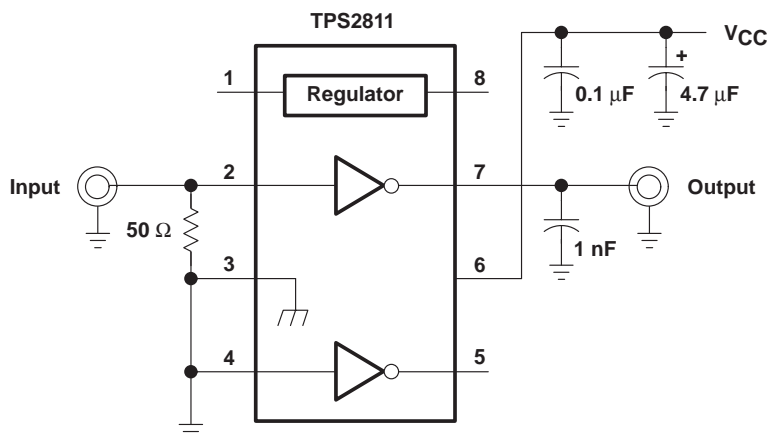

NOTE A: Input rise and fall times should be ≤10 ns for accurate measurement of ac parameters.

**Figure 1. Test Circuit For Measurement of Switching Characteristics**

# TPS2811, TPS2812, TPS2813, TPS2814, TPS2815 DUAL HIGH-SPEED MOSFET DRIVERS

SLVS132D – NOVEMBER 1995 – REVISED NOVEMBER 1997

## PARAMETER MEASUREMENT INFORMATION

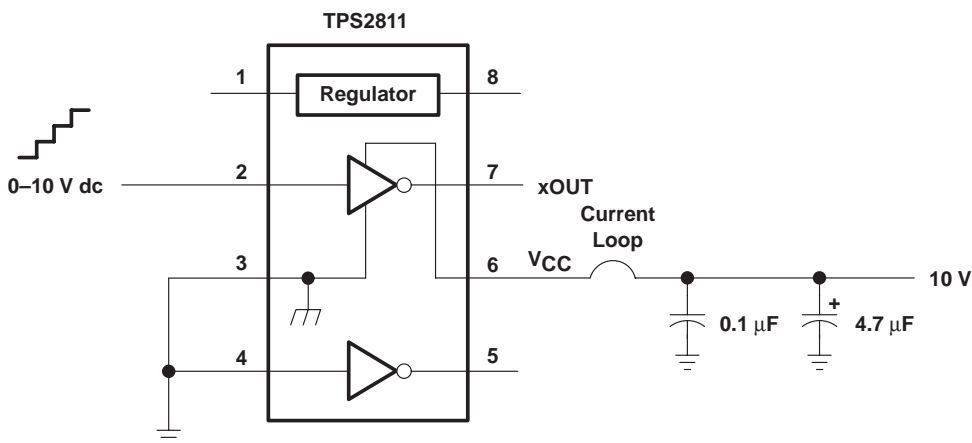

Figure 2. Shoot-through Current Test Setup

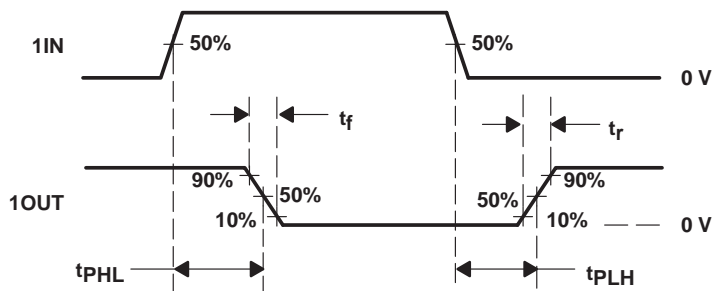

Figure 3. Typical Timing Diagram (TPS2811)

## TYPICAL CHARACTERISTICS

### Tables of Characteristics Graphs and Application Information

#### typical characteristics

PARAMETER	vs PARAMETER 2	FIGURE	PAGE
Rise time	Supply voltage	4	10
Fall time	Supply voltage	5	10
Propagation delay time	Supply voltage	6, 7	10
Supply current	Supply voltage	8	11
	Load capacitance	9	11
	Ambient temperature	10	11
Input threshold voltage	Supply voltage	11	11
Regulator output voltage	Regulator input voltage	12, 13	12
Regulator quiescent current	Regulator input voltage	14	12
Peak source current	Supply voltage	15	12
Peak sink current	Supply voltage	16	13
Shoot-through current	Input voltage, high-to-low	17	13
	Input voltage, low-to-high	18	13



POST OFFICE BOX 655303 • DALLAS, TEXAS 75265



# TPS2811, TPS2812, TPS2813, TPS2814, TPS2815 DUAL HIGH-SPEED MOSFET DRIVERS

SLVS132D – NOVEMBER 1995 – REVISED NOVEMBER 1997

## TYPICAL CHARACTERISTICS

### Tables of Characteristics Graphs and Application Information (Continued)

#### general applications

PARAMETER	vs PARAMETER 2		FIGURE	PAGE
Switching test circuits and application information			19, 20	15
Voltage of 1OUT vs 2OUT	Time	Low-to-high	21, 23, 25	16, 17
		High-to-low	22, 24, 26	16, 17

#### circuit for measuring paralleled switching characteristics

PARAMETER	vs PARAMETER 2		FIGURE	PAGE
Switching test circuits and application information			27	17
Input voltage vs output voltage	Time	Low-to-high	28, 30	18
		High-to-low	29, 31	18

#### Hex-1 to Hex-4 application information

PARAMETER	vs PARAMETER 2		FIGURE	PAGE
Driving test circuit and application information			32	19
Drain-source voltage vs drain current	Time	Hex-1 size	33	20
		Hex-2 size	36	20
		Hex-3 size	39	21
		Hex-4 size	41	22
		Hex-4 size parallel drive	45	23
Drain-source voltage vs gate-source voltage at turn-on	Time	Hex-1 size	34	20
		Hex-2 size	37	21
		Hex-3 size	40	21
		Hex-4 size	43	22
		Hex-4 size parallel drive	46	23
Drain-source voltage vs gate-source voltage at turn-off	Time	Hex-1 size	35	20
		Hex-2 size	38	21
		Hex-3 size	42	22
		Hex-4 size	44	22
		Hex-4 size parallel drive	47	23

#### synchronous buck regulator application

PARAMETER	vs PARAMETER 2		FIGURE	PAGE
3.3-V 3-A Synchronous-Rectified Buck Regulator Circuit			48	24
Q1 drain voltage vs gate voltage at turn-on	Time		49	26
Q1 drain voltage vs gate voltage at turn-off			50	26
Q1 drain voltage vs Q2 gate-source voltage			51, 52, 53	26, 27
Output ripple voltage vs inductor current		3 A	54	27
		5 A	55	27



# TPS2811, TPS2812, TPS2813, TPS2814, TPS2815 DUAL HIGH-SPEED MOSFET DRIVERS

SLVS132D – NOVEMBER 1995 – REVISED NOVEMBER 1997

## TYPICAL CHARACTERISTICS

RISE TIME  
vs  
SUPPLY VOLTAGE

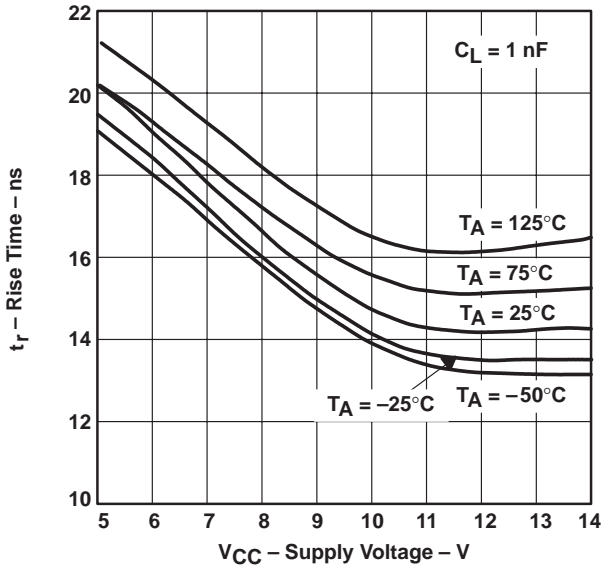

Figure 4

FALL TIME  
vs  
SUPPLY VOLTAGE

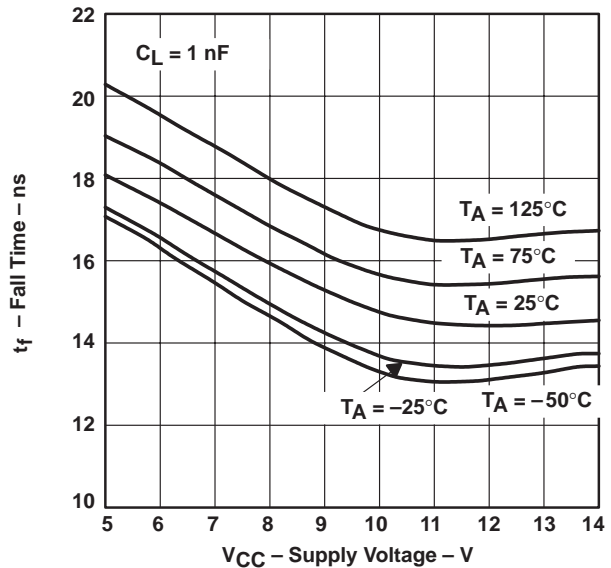

Figure 5

PROPAGATION DELAY TIME,  
HIGH-TO-LOW-LEVEL OUTPUT  
vs  
SUPPLY VOLTAGE

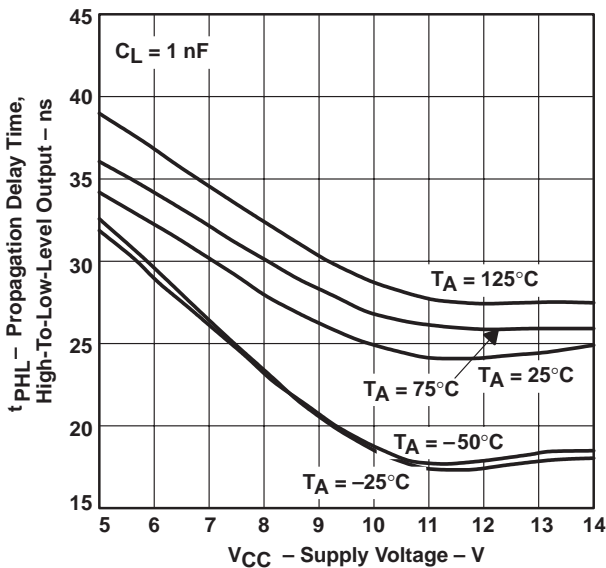

Figure 6

PROPAGATION DELAY TIME,  
LOW-TO-HIGH-LEVEL OUTPUT  
vs  
SUPPLY VOLTAGE

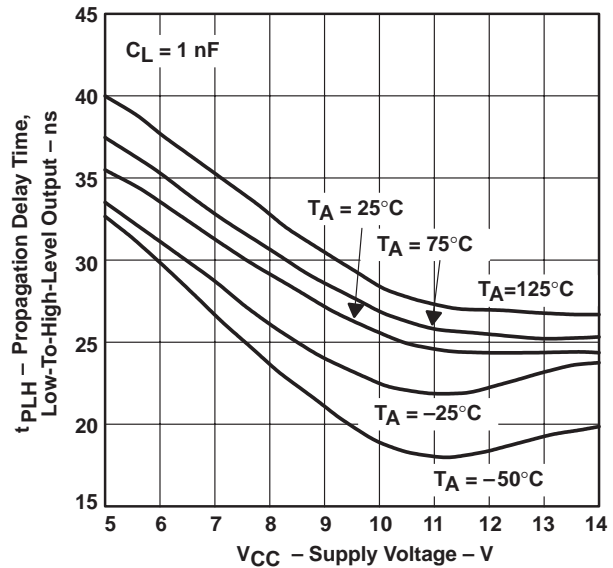

Figure 7

TYPICAL CHARACTERISTICS

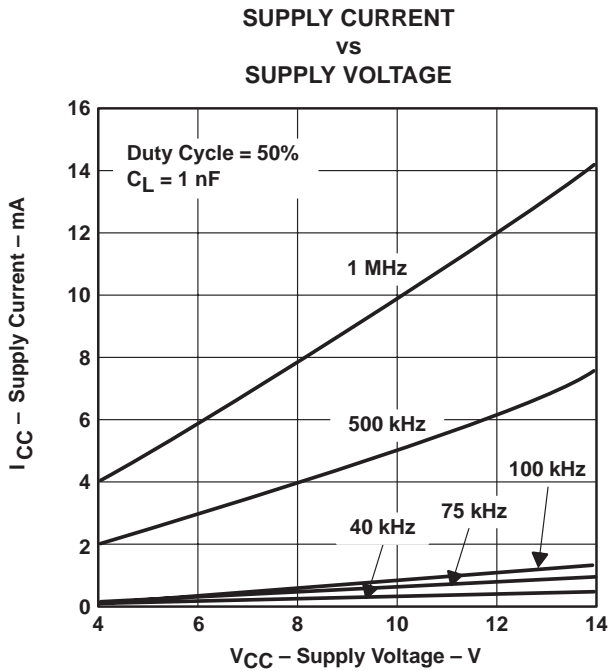

Figure 8

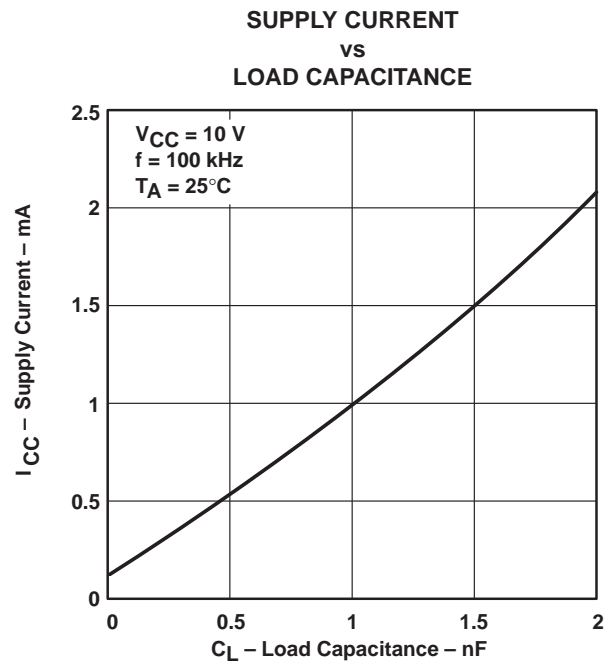

Figure 9

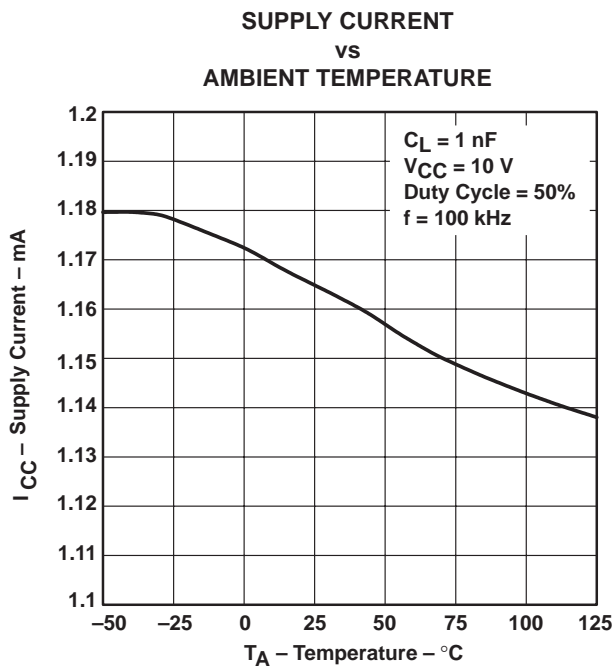

Figure 10

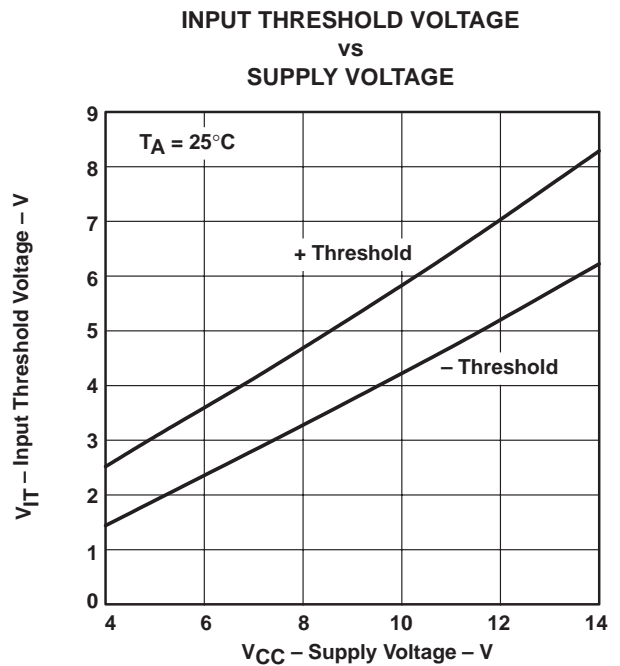

Figure 11

# TPS2811, TPS2812, TPS2813, TPS2814, TPS2815 DUAL HIGH-SPEED MOSFET DRIVERS

SLVS132D – NOVEMBER 1995 – REVISED NOVEMBER 1997

## TYPICAL CHARACTERISTICS

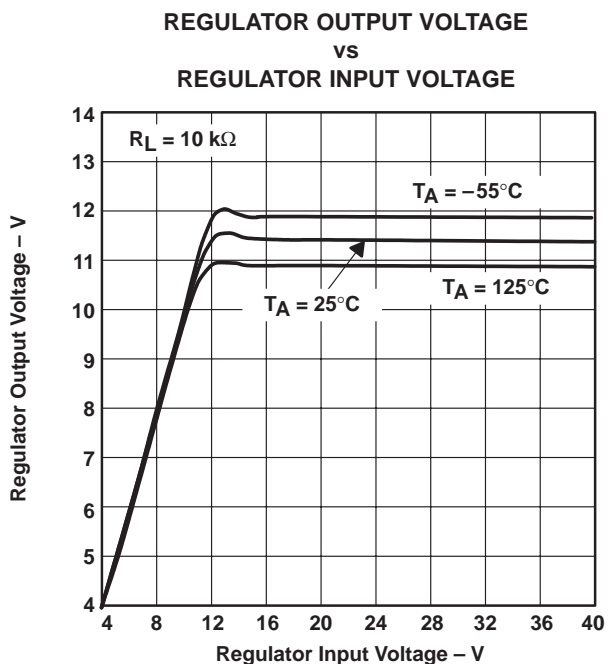

Figure 12

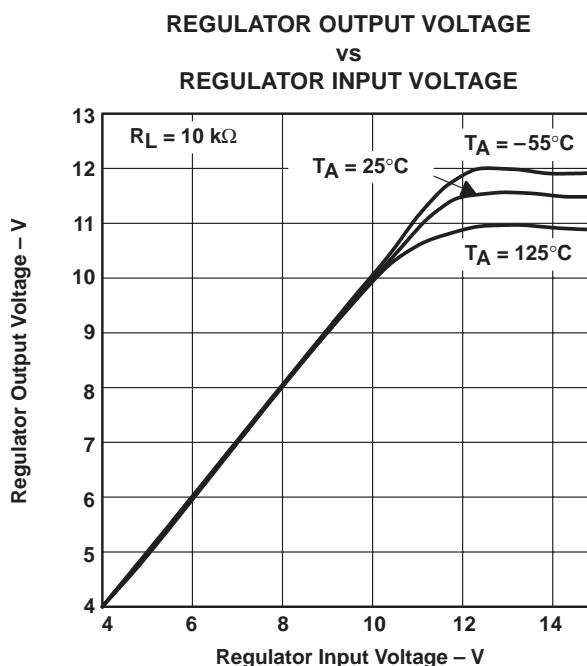

Figure 13

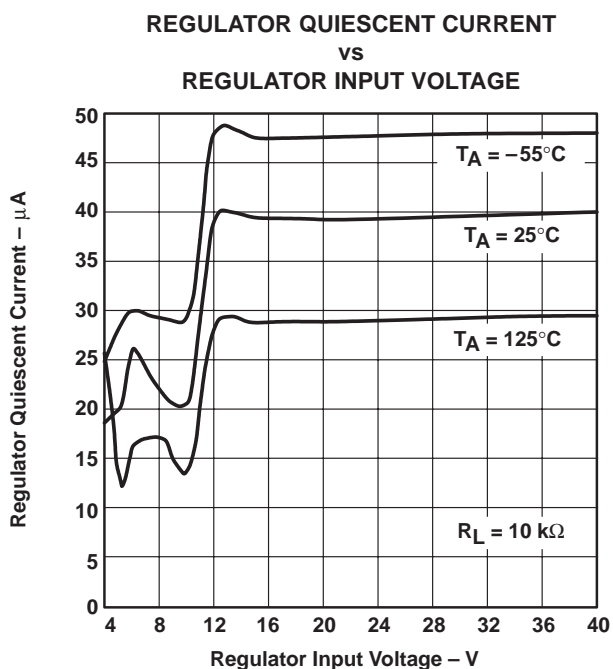

Figure 14

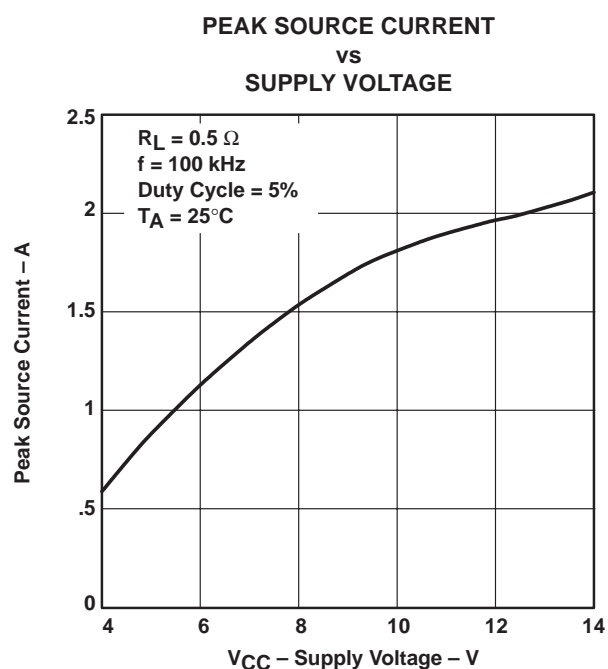

Figure 15



TYPICAL CHARACTERISTICS

PEAK SINK CURRENT  
 VS  
 SUPPLY VOLTAGE

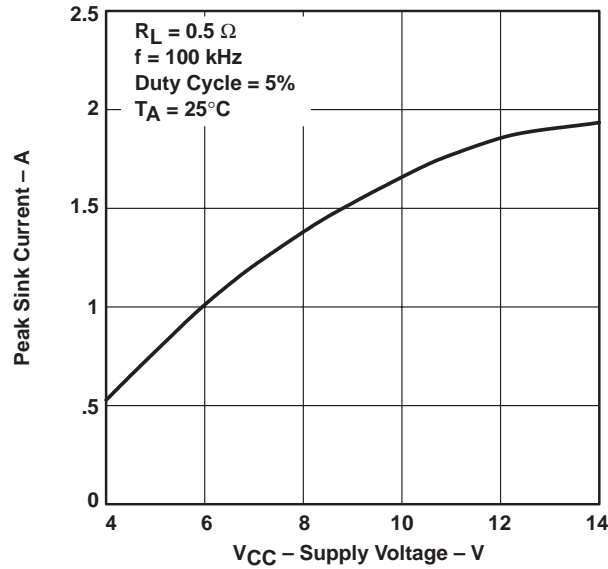

Figure 16

SHOOT-THROUGH CURRENT  
 VS  
 INPUT VOLTAGE, HIGH-TO-LOW

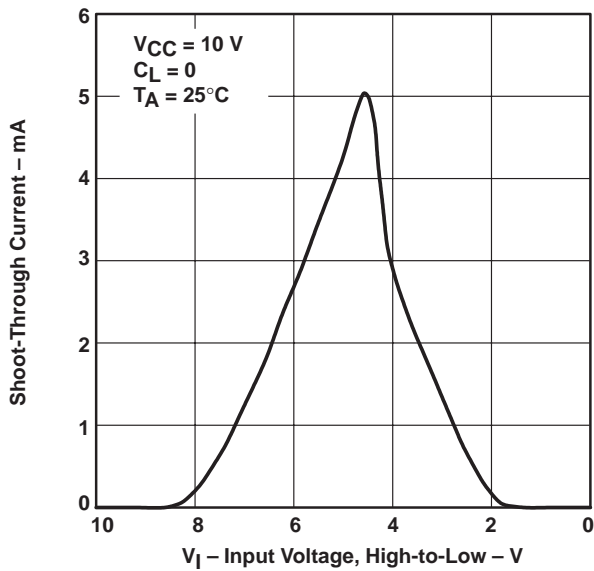

Figure 17

SHOOT-THROUGH CURRENT  
 VS  
 INPUT VOLTAGE, LOW-TO-HIGH

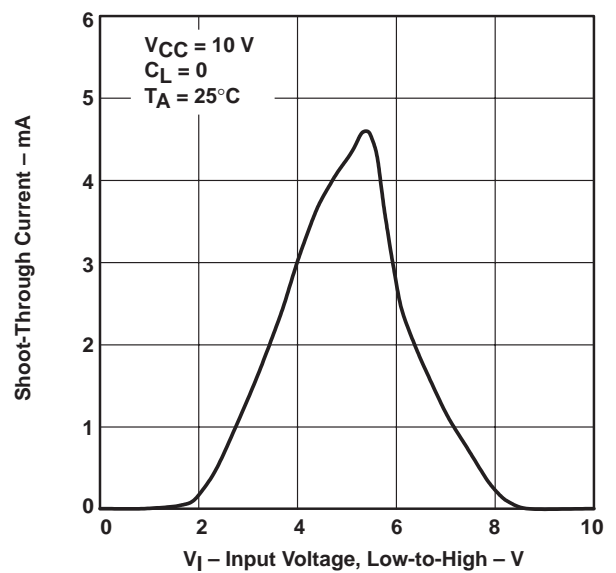

Figure 18

# TPS2811, TPS2812, TPS2813, TPS2814, TPS2815 DUAL HIGH-SPEED MOSFET DRIVERS

SLVS132D – NOVEMBER 1995 – REVISED NOVEMBER 1997

---

## APPLICATION INFORMATION

The TPS2811, TPS2812 and TPS2813 circuits each contain one regulator and two MOSFET drivers. The regulator can be used to limit  $V_{CC}$  to between 10 V and 13 V for a range of input voltages from 14 V to 40 V, while providing up to 20 mA of dc drive. The TPS2814 and TPS2815 both contain two drivers, each of which has two inputs. The TPS2811 has inverting drivers, the TPS2812 has noninverting drivers, and the TPS2813 has one inverting and one noninverting driver. The TPS2814 is a dual 2-input AND driver with one inverting input on each driver, and the TPS2815 is a dual 2-input NAND driver. These MOSFET drivers are capable of supplying up to 2.1 A or sinking up to 1.9 A (see Figures 15 and 16) of instantaneous current to n-channel or p-channel MOSFETs. The TPS2811 family of MOSFET drivers have very fast switching times combined with very short propagation delays. These features enhance the operation of today's high-frequency circuits.

The CMOS input circuit has a positive threshold of approximately 2/3 of  $V_{CC}$ , with a negative threshold of 1/3 of  $V_{CC}$ , and a very high input impedance in the range of  $10^9 \Omega$ . Noise immunity is also very high because of the Schmidt trigger switching. In addition, the design is such that the normal shoot-through current in CMOS (when the input is biased halfway between  $V_{CC}$  and ground) is limited to less than 6 mA. The limited shoot-through is evident in the graphs in Figures 17 and 18. The input stage shown in the functional block diagram better illustrates the way the front end works. The circuitry of the device is such that regardless of the rise and/or fall time of the input signal, the output signal will always have a fast transition speed; this basically isolates the waveforms at the input from the output. Therefore, the specified switching times are not affected by the slopes of the input waveforms.

The basic driver portion of the circuits operate over a supply voltage range of 4 V to 14 V with a maximum bias current of 5  $\mu$ A. Each driver consists of a CMOS input and a buffered output with a 2-A instantaneous drive capability. They have propagation delays of less than 30 ns and rise and fall times of less than 20 ns each. Placing a 0.1- $\mu$ F ceramic capacitor between  $V_{CC}$  and ground is recommended; this will supply the instantaneous current needed by the fast switching and high current surges of the driver when it is driving a MOSFET.

The output circuit is also shown in the functional block diagram. This driver uses a unique combination of a bipolar transistor in parallel with a MOSFET for the ability to swing from  $V_{CC}$  to ground while providing 2 A of instantaneous driver current. This unique parallel combination of bipolar and MOSFET output transistors provides the drive required at  $V_{CC}$  and ground to guarantee turn-off of even low-threshold MOSFETs. Typical bipolar-only output devices don't easily approach  $V_{CC}$  or ground.

The regulator, included in the TPS2811, TPS2812 and TPS2813, has an input voltage range of 14 V to 40 V. It produces an output voltage of 10 V to 13 V and is capable of supplying from 0 to 20 mA of output current. In grounded source applications, this extends the overall circuit operation to 40 V by clamping the driver supply voltage ( $V_{CC}$ ) to a safe level for both the driver and the MOSFET gate. The bias current for full operation is a maximum of 150  $\mu$ A. A 0.1- $\mu$ F capacitor connected between the regulator output and ground is required to ensure stability. For transient response, an additional 4.7- $\mu$ F electrolytic capacitor on the output and a 0.1- $\mu$ F ceramic capacitor on the input will optimize the performance of this circuit. When the regulator is not in use, it can be left open at both the input and the output, or the input can be shorted to the output and tied to either the  $V_{CC}$  or the ground pin of the chip.



POST OFFICE BOX 655303 • DALLAS, TEXAS 75265

APPLICATION INFORMATION

matching and paralleling connections

Figures 21 and 22 show the delays for the rise and fall time of each channel. As can be seen on a 5-ns scale, there is very little difference between the two channels at no load. Figures 23 and 24 show the difference between the two channels for a 1-nF load on each output. There is a slight delay on the rising edge, but little or no delay on the falling edge. As an example of extreme overload, Figures 25 and 26 show the difference between the two channels, or two drivers in the package, each driving a 10-nF load. As would be expected, the rise and fall times are significantly slowed down. Figures 28 and 29 show the effect of paralleling the two channels and driving a 1-nF load. A noticeable improvement is evident in the rise and fall times of the output waveforms. Finally, Figures 30 and 31 show the two drivers being paralleled to drive the 10-nF load and as could be expected the waveforms are improved. In summary, the paralleling of the two drivers in a package enhances the capability of the drivers to handle a larger load. Because of manufacturing tolerances, it is not recommended to parallel drivers that are not in the same package.

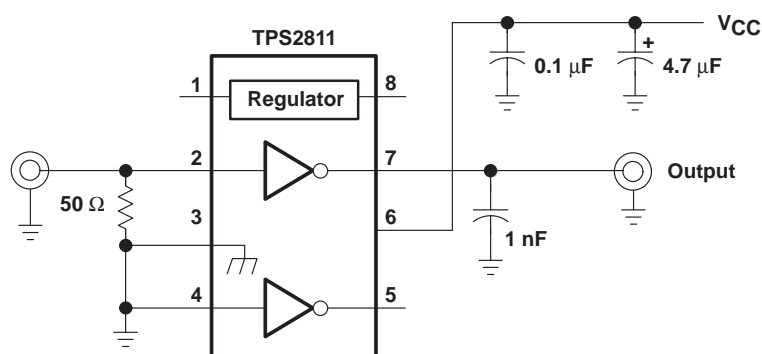
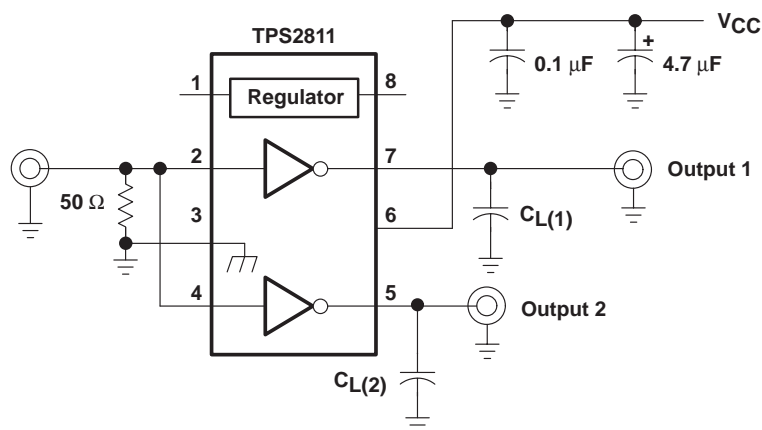

Figure 19. Test Circuit for Measuring Switching Characteristics



NOTE A: Input rise and fall times should be  $\leq 10$  ns for accurate measurement of ac parameters.

Figure 20. Test Circuit for Measuring Switching Characteristics with the Inputs Connected in Parallel

# TPS2811, TPS2812, TPS2813, TPS2814, TPS2815 DUAL HIGH-SPEED MOSFET DRIVERS

SLVS132D – NOVEMBER 1995 – REVISED NOVEMBER 1997

## APPLICATION INFORMATION

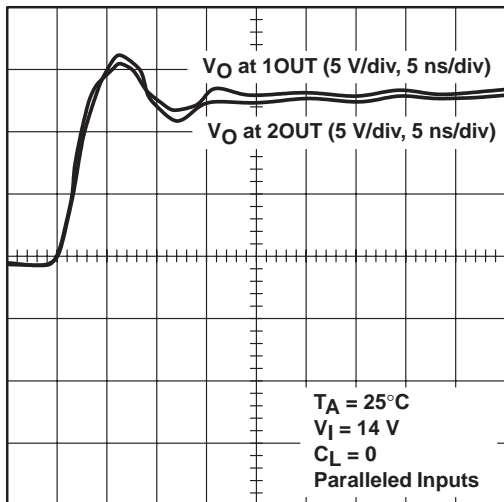

t – Time

Figure 21. Voltage of 1OUT vs Voltage at 2OUT, Low-to-High Output Delay

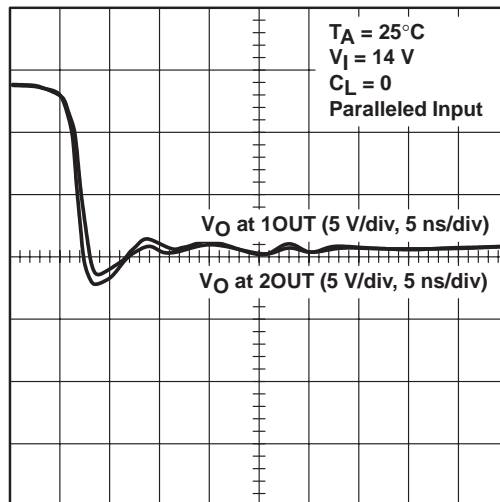

t – Time

Figure 22. Voltage at 1OUT vs Voltage at 2OUT, High-to-Low Output Delay

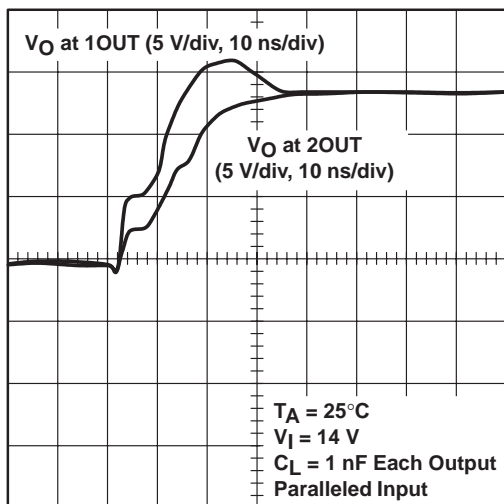

t – Time

Figure 23. Voltage at 1OUT vs Voltage at 2OUT, Low-to-High Output Delay

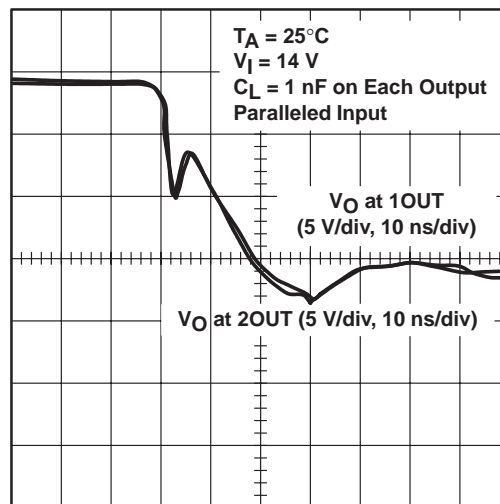

t – Time

Figure 24. Voltage at 1OUT vs Voltage at 2OUT, High-to-Low Output Delay



APPLICATION INFORMATION

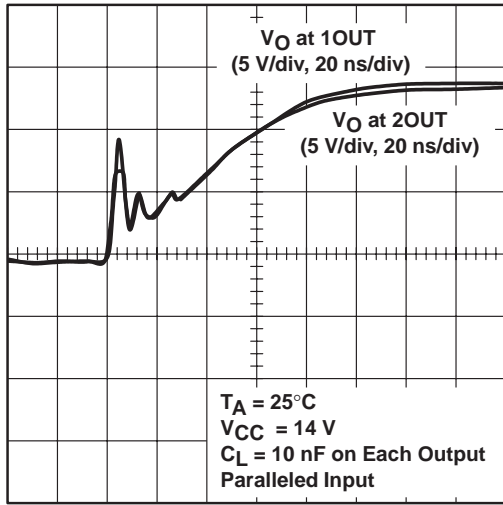

t – Time

Figure 25. Voltage at 1OUT vs Voltage at 2OUT, Low-to-High Output Delay

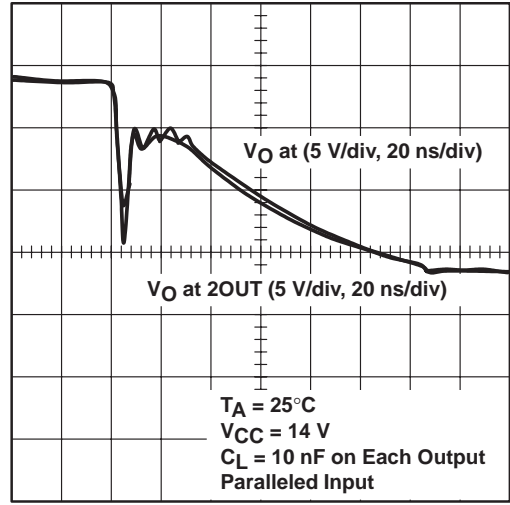

t – Time

Figure 26. Voltage at 1OUT vs Voltage at 2OUT, High-to-Low Output Delay

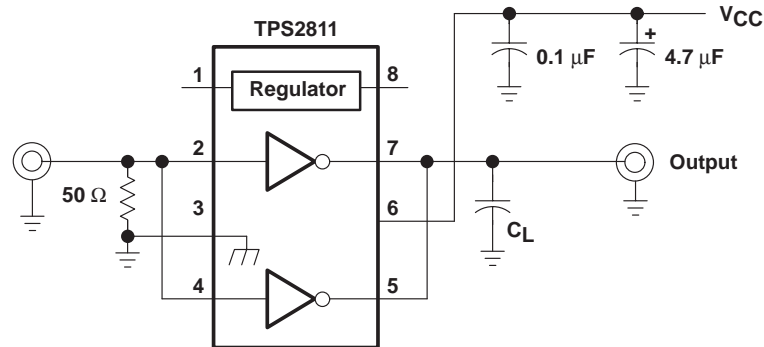

NOTE A: Input rise and fall times should be  $\leq 10$  ns for accurate measurement of ac parameters.

Figure 27. Test Circuit for Measuring Paralleled Switching Characteristics

# TPS2811, TPS2812, TPS2813, TPS2814, TPS2815 DUAL HIGH-SPEED MOSFET DRIVERS

SLVS132D – NOVEMBER 1995 – REVISED NOVEMBER 1997

## APPLICATION INFORMATION

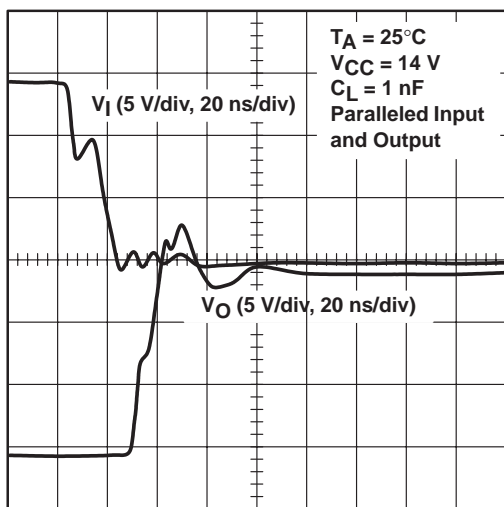

t – Time

**Figure 28. Input Voltage vs Output Voltage, Low-to-High Propagation Delay of Paralleled Drivers**

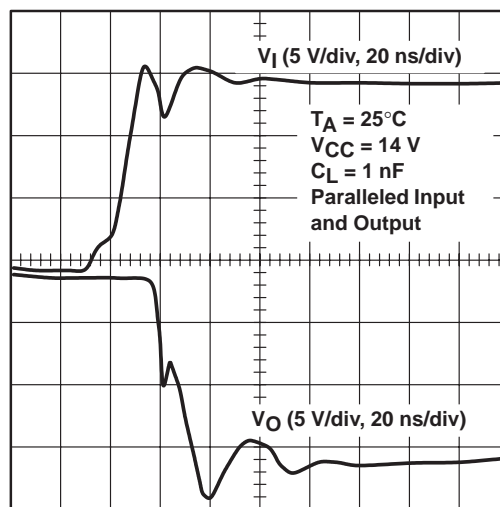

t – Time

**Figure 29. Input Voltage vs Output Voltage, High-to-Low Propagation Delay of Paralleled Drivers**

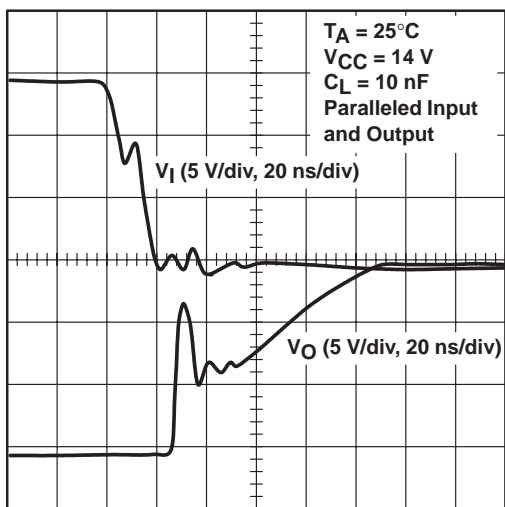

t – Time

**Figure 30. Input Voltage vs Output Voltage, Low-to-High Propagation Delay of Paralleled Drivers**

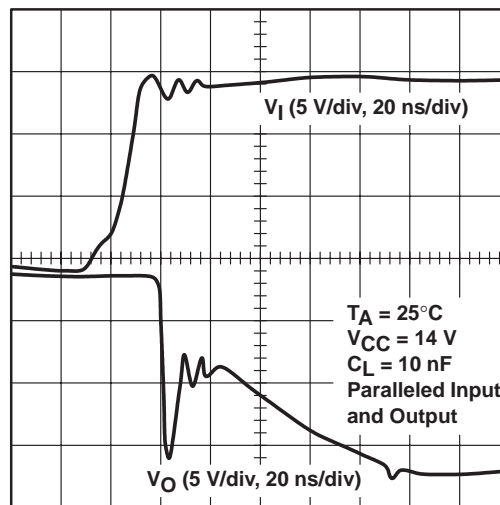

t – Time

**Figure 31. Input Voltage vs Output Voltage, High-to-Low Propagation Delay of Paralleled Drivers**

APPLICATION INFORMATION

Figures 33 through 47 illustrate the performance of the TPS2811 driving MOSFETs with clamped inductive loads, similar to what is encountered in discontinuous-mode flyback converters. The MOSFETs that were tested range in size from Hex-1 to Hex-4, although the TPS28xx family is only recommended for Hex-3 or below.

The test circuit is shown in Figure 32. The layout rules observed in building the test circuit also apply to real applications. Decoupling capacitor C1 is a 0.1- $\mu$ F ceramic device, connected between V<sub>CC</sub> and GND of the TPS2811, with short lead lengths. The connection between the driver output and the MOSFET gate, and between GND and the MOSFET source, are as short as possible to minimize inductance. Ideally, GND of the driver is connected directly to the MOSFET source. The tests were conducted with the pulse generator frequency set very low to eliminate the need for heat sinking, and the duty cycle was set to turn off the MOSFET when the drain current reached 50% of its rated value. The input voltage was adjusted to clamp the drain voltage at 80% of its rating.

As shown, the driver is capable of driving each of the Hex-1 through Hex-3 MOSFETs to switch in 20 ns or less. Even the Hex-4 is turned on in less than 20 ns. Figures 45, 46 and 47 show that paralleling the two drivers in a package enhances the gate waveforms and improves the switching speed of the MOSFET. Generally, one driver is capable of driving up to a Hex-4 size. The TPS2811 family is even capable of driving large MOSFETs that have a low gate charge.

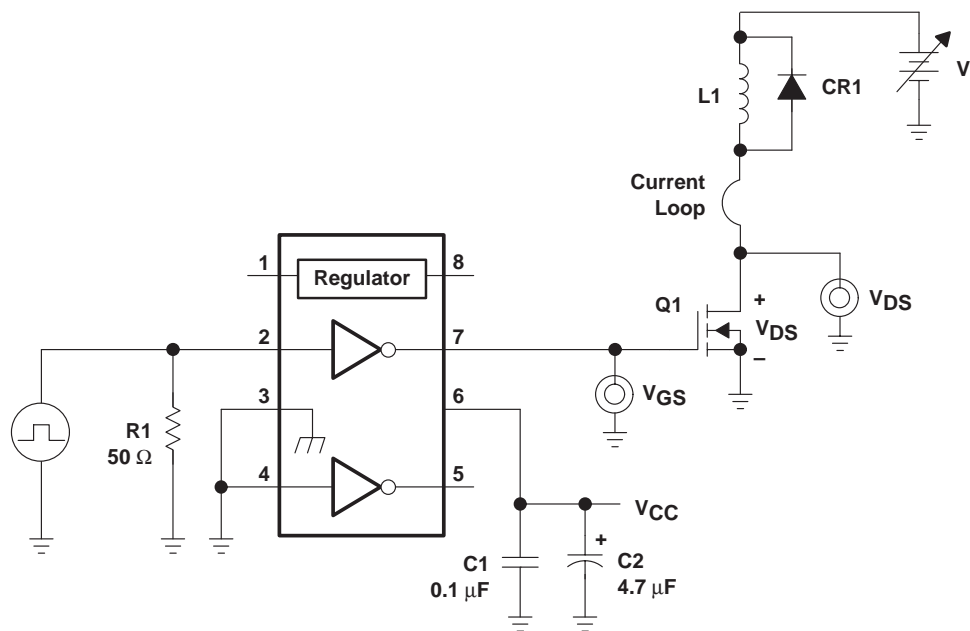
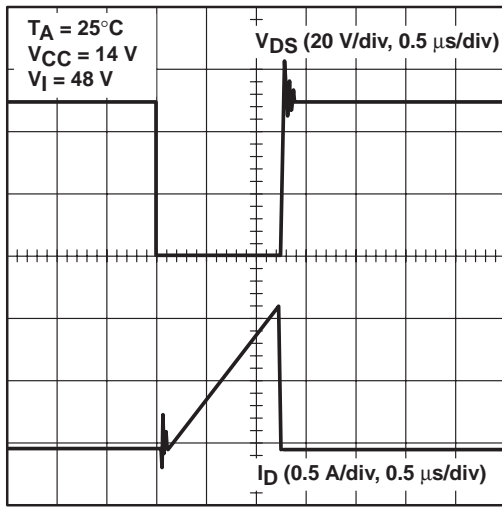

Figure 32. TPS2811 Driving Hex-1 through Hex-4 Devices

# TPS2811, TPS2812, TPS2813, TPS2814, TPS2815 DUAL HIGH-SPEED MOSFET DRIVERS

SLVS132D – NOVEMBER 1995 – REVISED NOVEMBER 1997

## APPLICATION INFORMATION



t – Time

Figure 33. Drain-Source Voltage vs Drain Current, TPS2811 Driving an IRFD014 (Hex-1 Size)

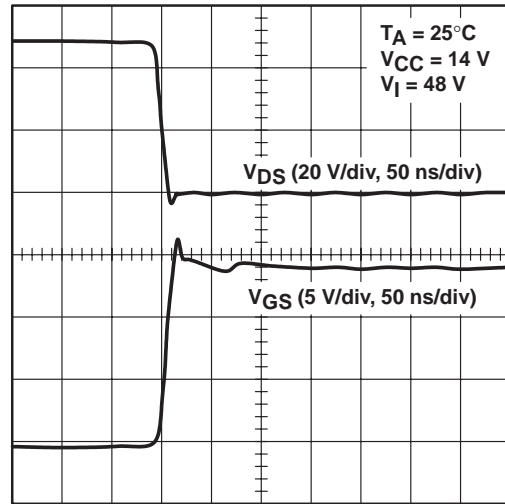

t – Time

Figure 34. Drain-Source Voltage vs Gate-Source Voltage, at Turn-on, TPS2811 Driving an IRFD014 (Hex-1 Size)

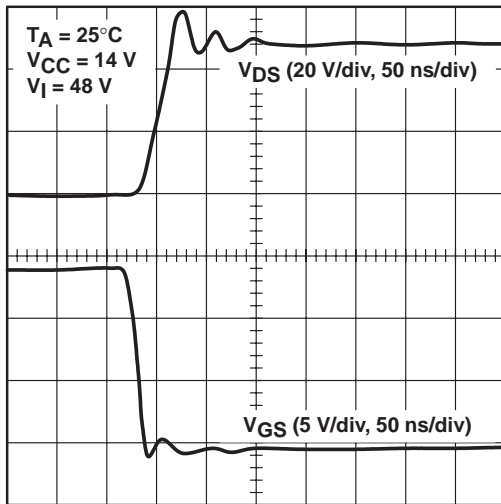

t – Time

Figure 35. Drain-Source Voltage vs Gate-Source Voltage, at Turn-off, TPS2811 Driving an IRFD014 (Hex-1 Size)

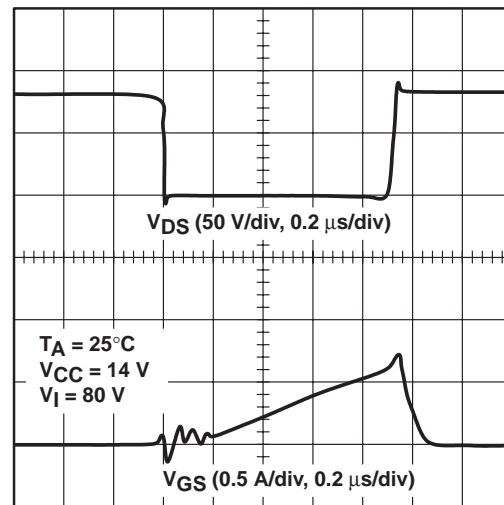

t – Time

Figure 36. Drain-Source Voltage vs Drain Current, TPS2811 Driving an IRFD120 (Hex-2 Size)

APPLICATION INFORMATION

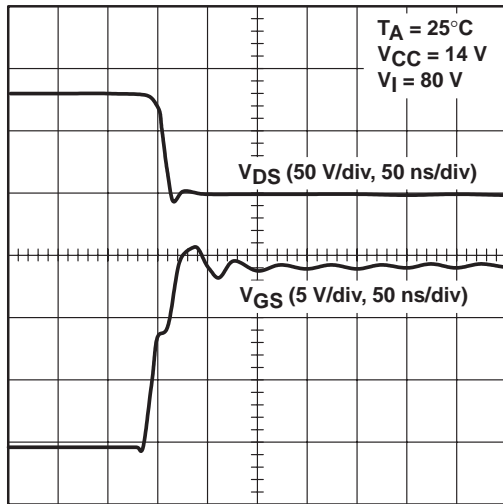

t – Time

Figure 37. Drain-Source Voltage vs Gate-Source Voltage, at Turn-on, TPS2811 Driving an IRFD120 (Hex-2 Size)

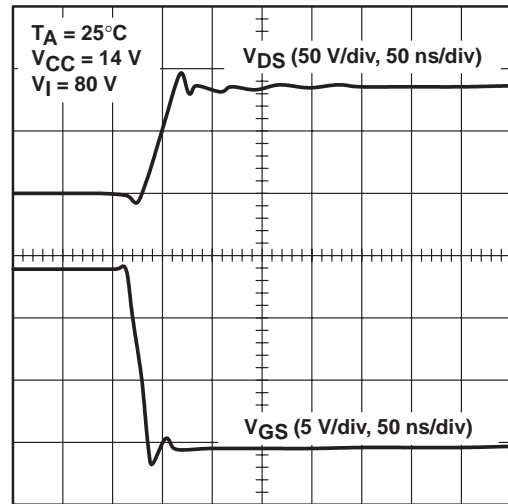

t – Time

Figure 38. Drain-Source Voltage vs Gate-Source Voltage, at Turn-off, TPS2811 Driving an IRFD120 (Hex-2 Size)

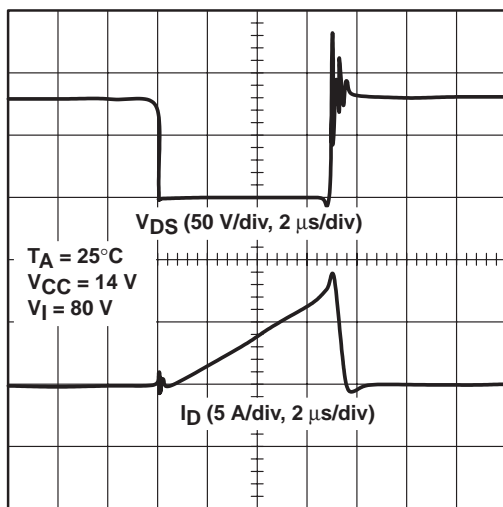

t – Time

Figure 39. Drain-Source Voltage vs Drain Current, TPS2811 Driving an IRF530 (Hex-3 Size)

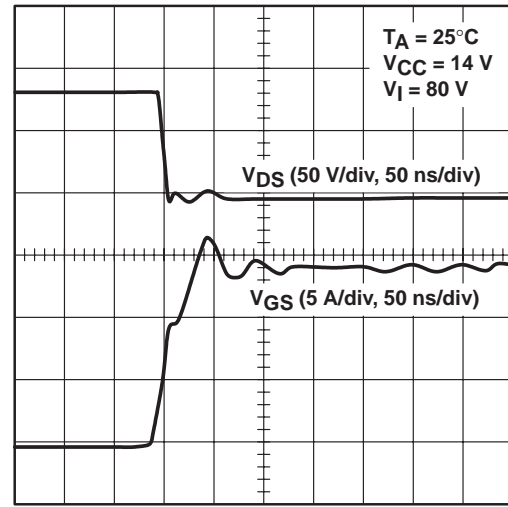

t – Time

Figure 40. Drain-Source Voltage vs Gate-Source Voltage, at Turn-on, TPS2811 Driving an IRF530 (Hex-3 Size)

# TPS2811, TPS2812, TPS2813, TPS2814, TPS2815 DUAL HIGH-SPEED MOSFET DRIVERS

SLVS132D – NOVEMBER 1995 – REVISED NOVEMBER 1997

## APPLICATION INFORMATION

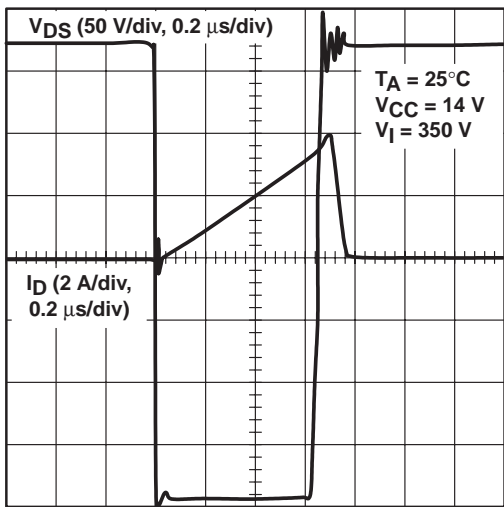

t – Time

**Figure 41. Drain-Source Voltage vs Drain Current, One Driver, TPS2811 Driving an IRF840 (Hex-4 Size)**

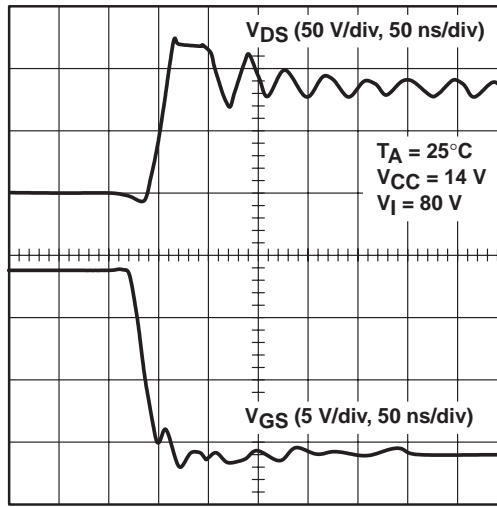

t – Time

**Figure 42. Drain-Source Voltage vs Gate-Source Voltage, at Turn-off, TPS2811 Driving an IRF530 (Hex-3 Size)**

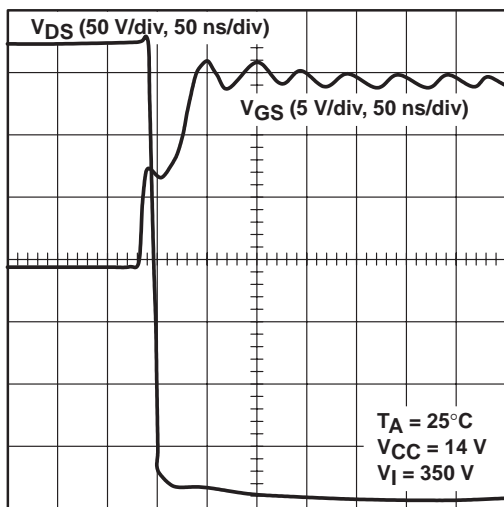

t – Time

**Figure 43. Drain-Source Voltage vs Gate-Source Voltage, at Turn-on, One Driver, TPS2811 Driving an IRF840 (Hex-4 Size)**

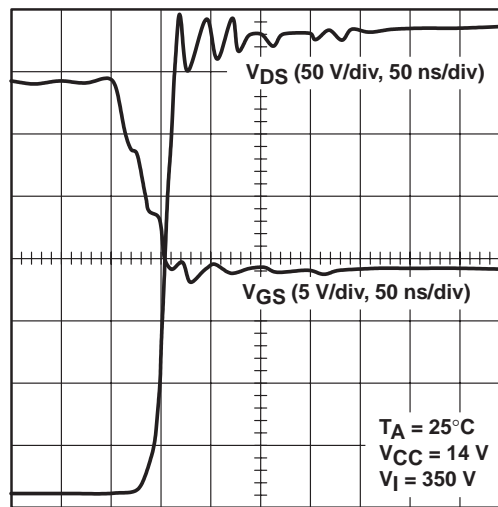

t – Time

**Figure 44. Drain-Source Voltage vs Gate-Source Voltage, at Turn-off, One Driver, TPS2811 Driving an IRF840 (Hex-4 Size)**

APPLICATION INFORMATION

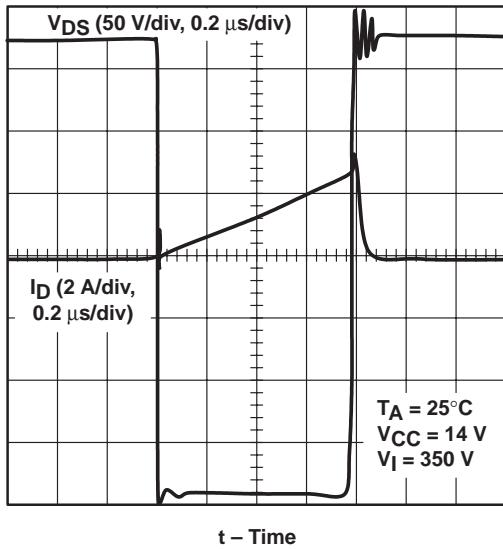

Figure 45. Drain-Source Voltage vs Drain Current, Parallel Drivers, TPS2811 Driving an IRF840 (Hex-4 Size)

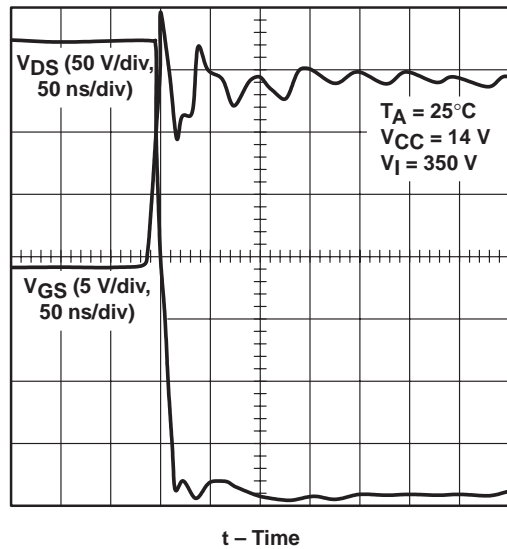

Figure 46. Drain-Source Voltage vs Gate-Source Voltage, at Turn-on, Parallel Drivers, TPS2811 Driving an IRF840 (Hex-4 Size)

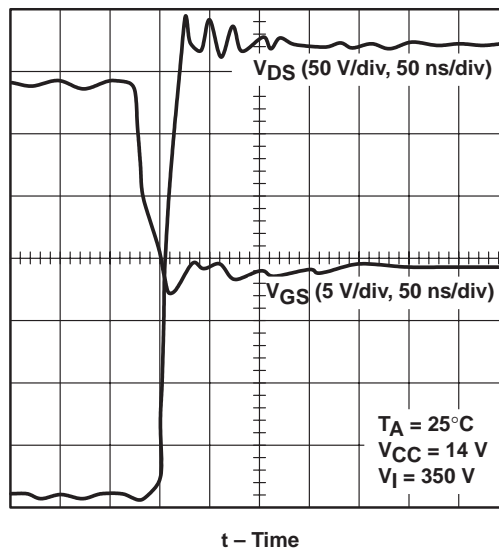

Figure 47. Drain-Source Voltage vs Gate-Source Voltage, at Turn-off, Parallel Drivers, TPS2811 Driving an IRF840 (Hex-4 Size)

# TPS2811, TPS2812, TPS2813, TPS2814, TPS2815 DUAL HIGH-SPEED MOSFET DRIVERS

SLVS132D – NOVEMBER 1995 – REVISED NOVEMBER 1997

## APPLICATION INFORMATION

### synchronous buck regulator

Figure 48 is the schematic for a 100-kHz synchronous-rectified buck converter implemented with a TL5001 pulse-width-modulation (PWM) controller and a TPS2812 driver. The bill of materials is provided in Table 1. The converter operates over an input range from 5.5 V to 12 V and has a 3.3-V output capable of supplying 3 A continuously and 5 A during load surges. The converter achieves an efficiency of 90.6% at 3 A and 87.6% at 5 A. Figures 49 and 50 show the power switch switching performance. The output ripple voltage waveforms are documented in Figures 54 and 55.

The TPS2812 drives both the power switch, Q2, and the synchronous rectifier, Q1. Large shoot-through currents, caused by power switch and synchronous rectifier remaining on simultaneously during the transitions, are prevented by small delays built into the drive signals, using CR2, CR3, R11, R12, and the input capacitance of the TPS2812. These delays allow the power switch to turn off before the synchronous rectifier turns on and vice versa. Figure 51 shows the delay between the drain of Q2 and the gate of Q1; expanded views are provided in Figures 52 and 53.

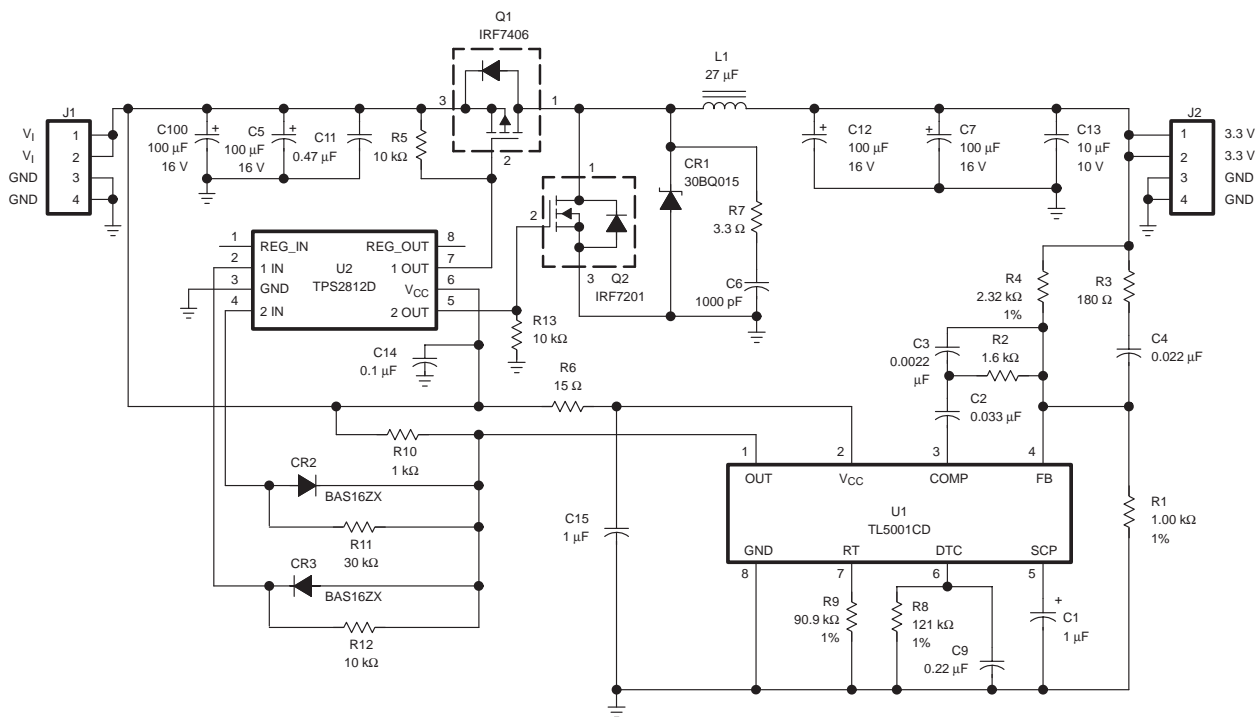

Figure 48. 3.3-V 3-A Synchronous-Rectified Buck Regulator Circuit



# TPS2811, TPS2812, TPS2813, TPS2814, TPS2815 DUAL HIGH-SPEED MOSFET DRIVERS

SLVS132D – NOVEMBER 1995 – REVISED NOVEMBER 1997

## APPLICATION INFORMATION

**Table 1. Bill of Materials,  
3.3-V, 3-A Synchronous-Rectified Buck Converter**

REFERENCE	DESCRIPTION	VENDOR	
U1	TL5001CD, PWM	Texas Instruments,	972-644-5580
U2	TPS2812D, N.I. MOSFET Driver	Texas Instruments,	972-644-5580
CR1	3 A, 15 V, Schottky, 30BQ015	International Rectifier,	310-322-3331
CR2,CR3	Signal Diode, BAS16ZX	Zetex,	516-543-7100
C1	1 $\mu$ F, 16 V, Tantalum		
C2	0.033 $\mu$ F, 50 V		
C3	0.0022 $\mu$ F, 50 V		
C4	0.022 $\mu$ F, 50 V		
C5,C7,C10,C12	100 $\mu$ F, 16 V, Tantalum, TPSE107M016R0100	AVX,	800-448-9411
C6	1000 pF, 50 V		
C9	0.22 $\mu$ F, 50 V		
C11	0.47 $\mu$ F, 50 V, Z5U		
C13	10 $\mu$ F, 10 V, Ceramic, CC1210CY5V106Z	TDK,	708-803-6100
C14	0.1 $\mu$ F, 50 V		
C15	1.0 $\mu$ F, 50 V		
J1,J2	4-Pin Header		
L1	27 $\mu$ H, 3 A/5 A, SML5040	Nova Magnetics, Inc.,	972-272-8287
Q1	IRF7406, P-FET	International Rectifier,	310-322-3331
Q2	IRF7201, N-FET	International Rectifier,	310-322-3331
R1	1.00 k $\Omega$ , 1%		
R2	1.6 k $\Omega$		
R3	180 $\Omega$		
R4	2.32 k $\Omega$ , 1 %		
R5,R12,R13	10 k $\Omega$		
R6	15 $\Omega$		
R7	3.3 $\Omega$		
R8	121 k $\Omega$ , 1%		
R9	90.9 k $\Omega$ , 1%		
R10	1 k $\Omega$		
R11	30 k $\Omega$		

NOTES: 2. Unless otherwise specified, capacitors are X7R ceramics.  
3. Unless otherwise specified, resistors are 5%, 1/10 W.



# TPS2811, TPS2812, TPS2813, TPS2814, TPS2815 DUAL HIGH-SPEED MOSFET DRIVERS

SLVS132D – NOVEMBER 1995 – REVISED NOVEMBER 1997

## APPLICATION INFORMATION

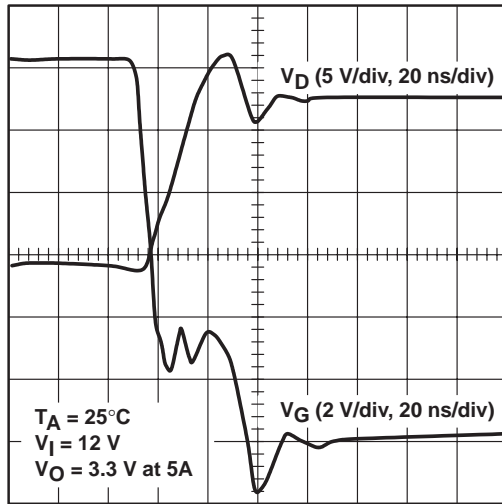

t – Time

Figure 49. Q1 Drain Voltage vs Gate Voltage, at Switch Turn-on

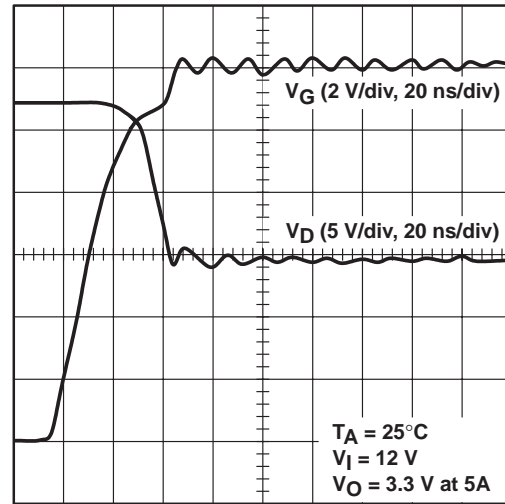

t – Time

Figure 50. Q1 Drain Voltage vs Gate Voltage, at Switch Turn-off

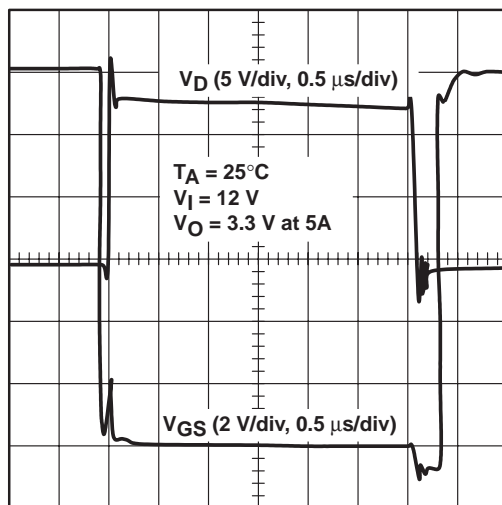

t – Time

Figure 51. Q1 Drain Voltage vs Q2 Gate-Source Voltage

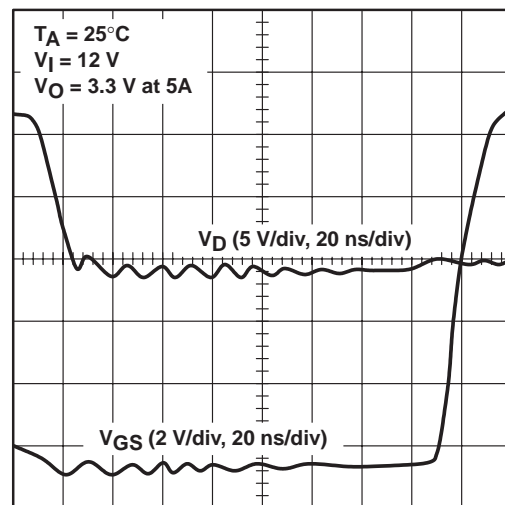

t – Time

Figure 52. Q1 Drain Voltage vs Q2 Gate-Source Voltage

APPLICATION INFORMATION

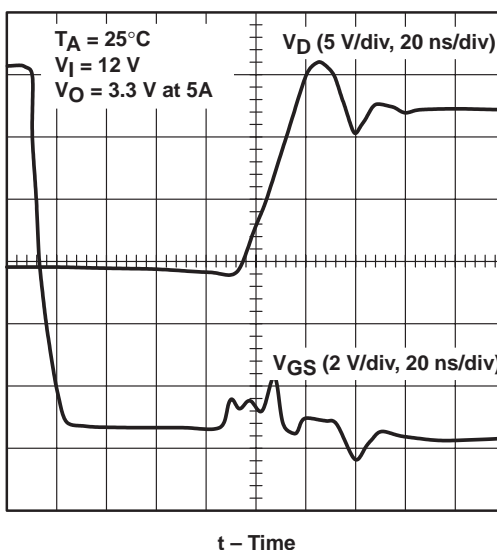

Figure 53. Q1 Drain Voltage vs Q2 Gate-Source Voltage

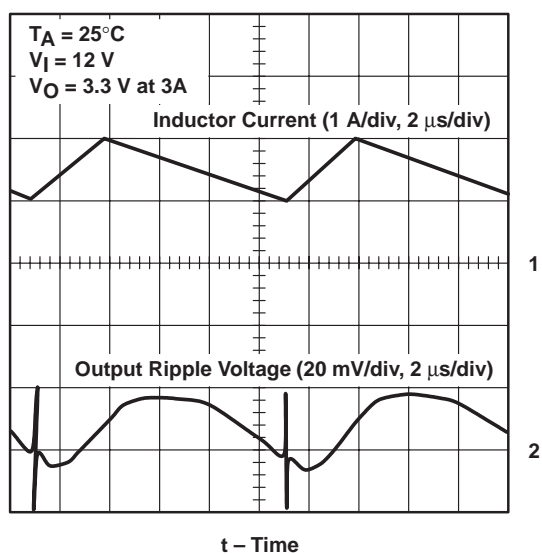

Figure 54. Output Ripple Voltage vs Inductor Current, at 3 A

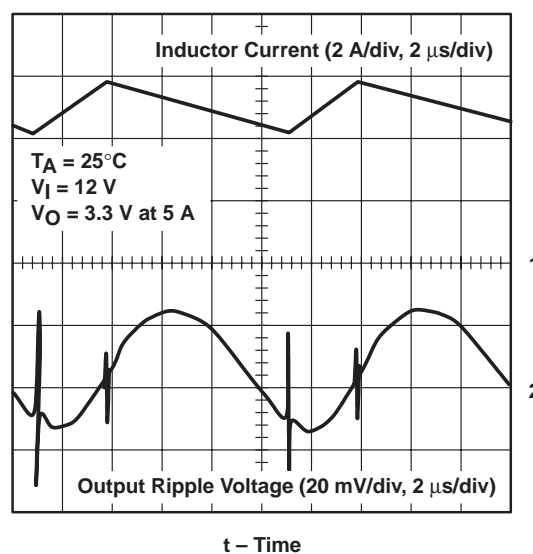

Figure 55. Output Ripple Voltage vs Inductor Current, at 5 A

# TPS2811, TPS2812, TPS2813, TPS2814, TPS2815 DUAL HIGH-SPEED MOSFET DRIVERS

SLVS132D – NOVEMBER 1995 – REVISED NOVEMBER 1997

## MECHANICAL DATA

D (R-PDSO-G\*\*)

PLASTIC SMALL-OUTLINE PACKAGE

14 PIN SHOWN

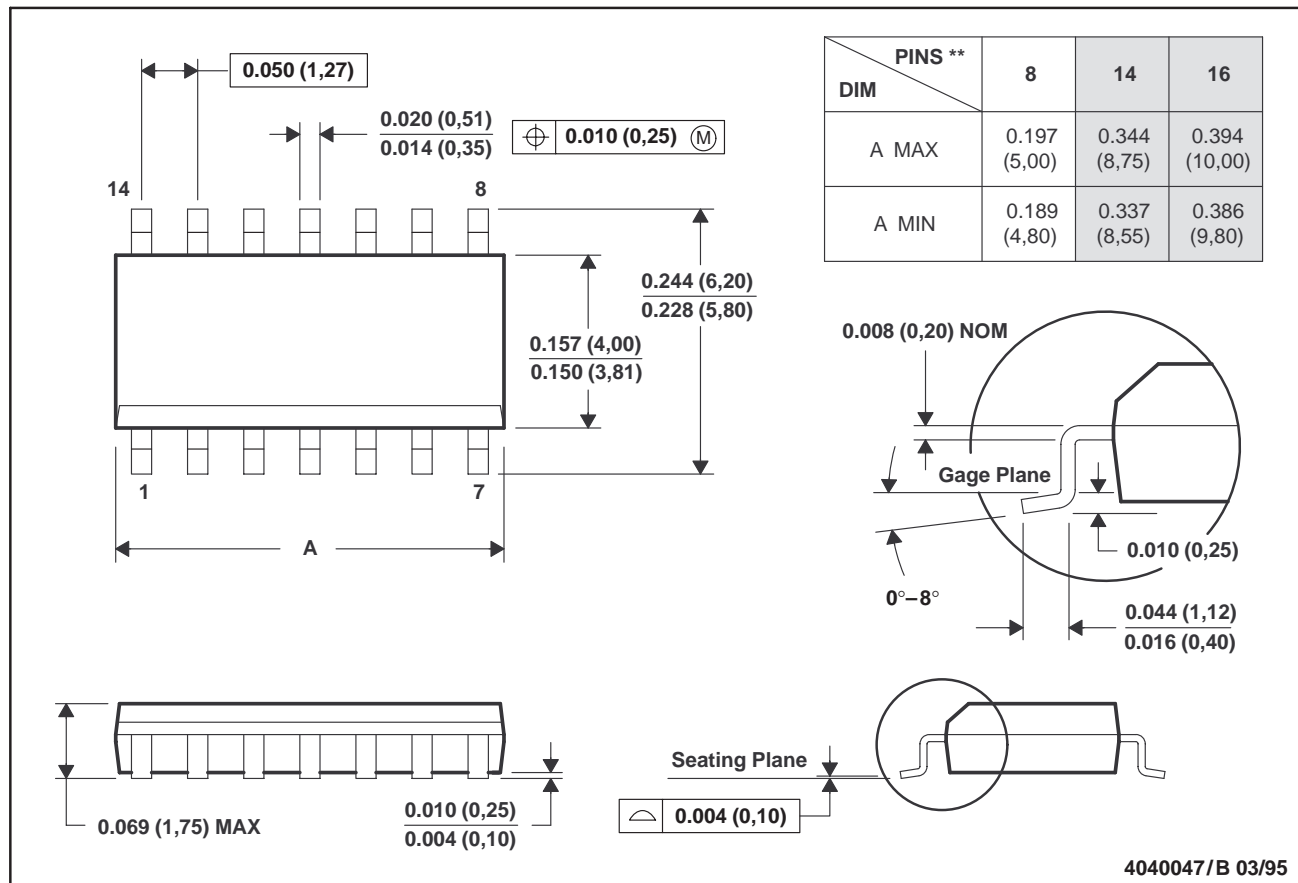

4040047/B 03/95

- NOTES:
- A. All linear dimensions are in inches (millimeters).
  - B. This drawing is subject to change without notice.
  - C. Body dimensions do not include mold flash or protrusion, not to exceed 0.006 (0,15).
  - D. Four center pins are connected to die mount pad.
  - E. Falls within JEDEC MS-012

# TPS2811, TPS2812, TPS2813, TPS2814, TPS2815 DUAL HIGH-SPEED MOSFET DRIVERS

SLVS132D – NOVEMBER 1995 – REVISED NOVEMBER 1997

## MECHANICAL DATA

P (R-PDIP-T8)

PLASTIC DUAL-IN-LINE PACKAGE

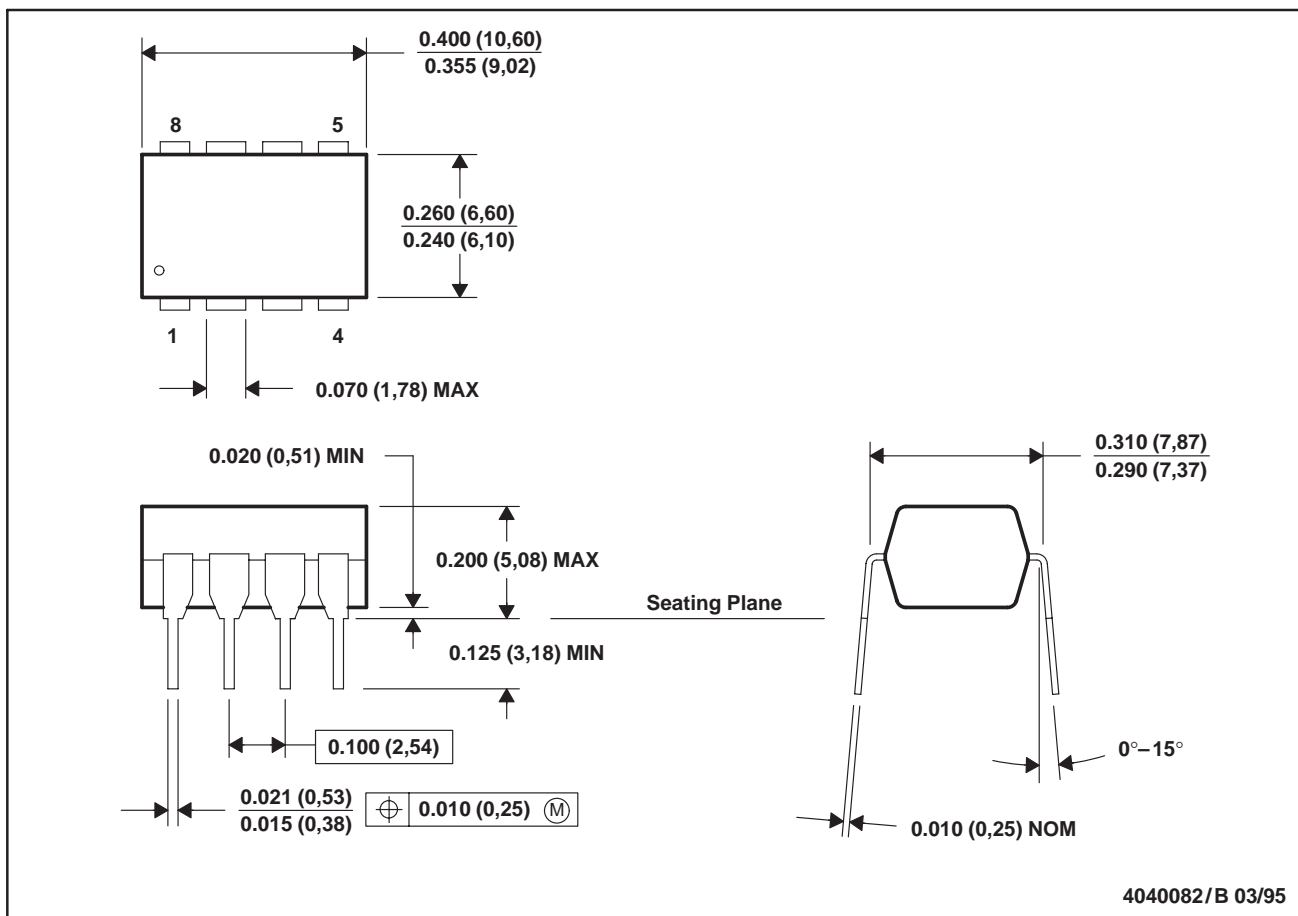

- NOTES: A. All linear dimensions are in inches (millimeters).  
B. This drawing is subject to change without notice.  
C. Falls within JEDEC MS-001

# TPS2811, TPS2812, TPS2813, TPS2814, TPS2815 DUAL HIGH-SPEED MOSFET DRIVERS

SLVS132D – NOVEMBER 1995 – REVISED NOVEMBER 1997

## MECHANICAL DATA

PW (R-PDSO-G\*\*)

PLASTIC SMALL-OUTLINE PACKAGE

14 PIN SHOWN

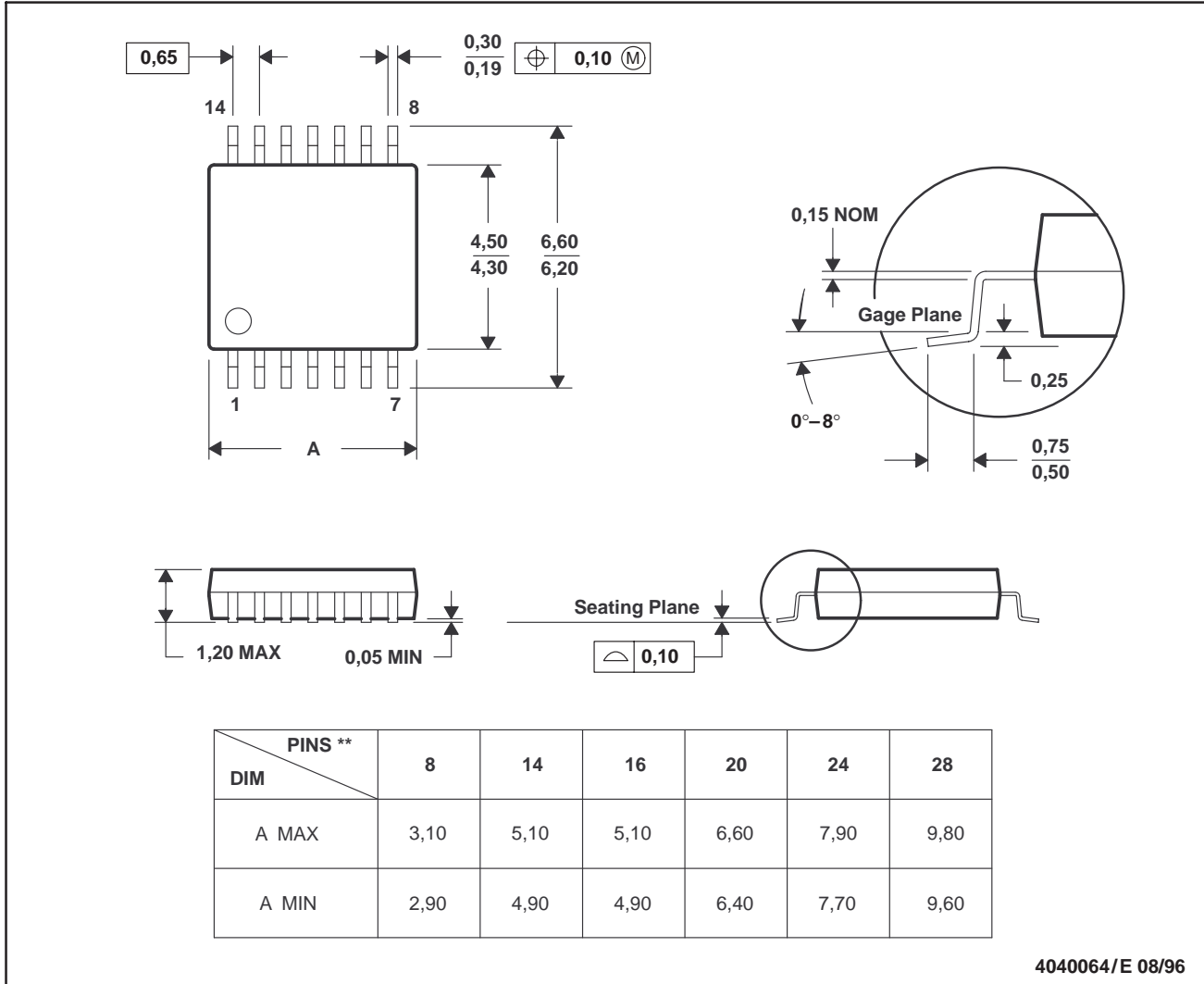

4040064/E 08/96

- NOTES: A. All linear dimensions are in millimeters.  
 B. This drawing is subject to change without notice.  
 C. Body dimensions do not include mold flash or protrusion not to exceed 0,15.  
 D. Falls within JEDEC MO-153

## **IMPORTANT NOTICE**

Texas Instruments and its subsidiaries (TI) reserve the right to make changes to their products or to discontinue any product or service without notice, and advise customers to obtain the latest version of relevant information to verify, before placing orders, that information being relied on is current and complete. All products are sold subject to the terms and conditions of sale supplied at the time of order acknowledgement, including those pertaining to warranty, patent infringement, and limitation of liability.

TI warrants performance of its semiconductor products to the specifications applicable at the time of sale in accordance with TI's standard warranty. Testing and other quality control techniques are utilized to the extent TI deems necessary to support this warranty. Specific testing of all parameters of each device is not necessarily performed, except those mandated by government requirements.

**CERTAIN APPLICATIONS USING SEMICONDUCTOR PRODUCTS MAY INVOLVE POTENTIAL RISKS OF DEATH, PERSONAL INJURY, OR SEVERE PROPERTY OR ENVIRONMENTAL DAMAGE ("CRITICAL APPLICATIONS"). TI SEMICONDUCTOR PRODUCTS ARE NOT DESIGNED, AUTHORIZED, OR WARRANTED TO BE SUITABLE FOR USE IN LIFE-SUPPORT DEVICES OR SYSTEMS OR OTHER CRITICAL APPLICATIONS. INCLUSION OF TI PRODUCTS IN SUCH APPLICATIONS IS UNDERSTOOD TO BE FULLY AT THE CUSTOMER'S RISK.**

In order to minimize risks associated with the customer's applications, adequate design and operating safeguards must be provided by the customer to minimize inherent or procedural hazards.

TI assumes no liability for applications assistance or customer product design. TI does not warrant or represent that any license, either express or implied, is granted under any patent right, copyright, mask work right, or other intellectual property right of TI covering or relating to any combination, machine, or process in which such semiconductor products or services might be or are used. TI's publication of information regarding any third party's products or services does not constitute TI's approval, warranty or endorsement thereof.