

# TRF8010 900-MHz RF TRANSMIT DRIVER

SLWS031B – JULY 1996 – REVISED MAY 1997

- Operates from 3.6-V and 4.8-V Power Supplies for AMPS/NADC and GSM Applications Respectively
- Unconditionally Stable
- Wide UHF Frequency Range  
800 MHz to 1000 MHz
- 21 dBm and 23 dBm Typical Output Power in AMPS/NADC and GSM Applications Respectively
- Linear Ramp Control
- Transmit Enable/Disable Control
- Advanced BiCMOS Processing Technology for Low-Power Consumption, High Efficiency, and Highly Linear Operation
- Minimum of External Components Required for Operation
- Surface-Mount Thermally Enhanced Package for Extremely Small Circuit Footprint

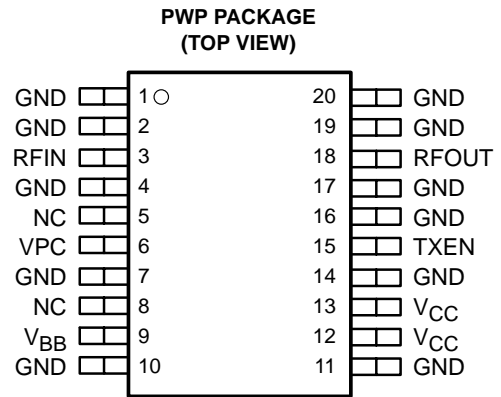

NC – No internal connection

## description

The TRF8010 is an RF transmit driver amplifier for 900-MHz digital, analog, and dual-mode communication applications. It consists of a two-stage amplifier and a linear ramp controller for burst control in TDMA (time division multiple access) applications. Very few external components are required for operation.

The TRF8010 amplifies the RF signal from the preceding modulator and upconverter stages in an RF section of a transmitter to a level that is sufficient to drive a final RF power output device. The output impedance of RFOUT is approximately 50 Ω. But, since RFOUT is connected to an open-collector output device, minimal external matching is required.

The device is enabled when the TXEN input is held high. A power control signal applied to the VPC input can ramp the RF output power up or down to meet ramp and spurious emission specifications in TDMA systems. The power control signal causes a linear change in output power as the voltage applied to VPC varies between 0 V and 3 V. With the RF input power applied to RFIN at 0 dBm and TXEN high, adjusting VPC from 0 V to 3 V increases the output power from a typical value of –54 dBm at VPC = 0 V to the output power appropriate for the application:

- 21 dBm typical for AMPS/NADC (Advanced Mobile Phone Service/North American Digital Cellular) operation
- 23 dBm typical for GSM (Global System for Mobile Communications) operation

Forward isolation with the RF input power applied to RFIN at 0 dBm, VPC = 0 V, and TXEN high is typically greater than 50 dB.



These devices have limited built-in ESD protection. The leads should be shorted together or the device placed in conductive foam during storage or handling to prevent electrostatic damage to the MOS gates.



Please be aware that an important notice concerning availability, standard warranty, and use in critical applications of Texas Instruments semiconductor products and disclaimers thereto appears at the end of this data sheet.

PRODUCTION DATA information is current as of publication date. Products conform to specifications per the terms of Texas Instruments standard warranty. Production processing does not necessarily include testing of all parameters.

 **TEXAS  
INSTRUMENTS**

POST OFFICE BOX 655303 • DALLAS, TEXAS 75265

Copyright © 1997, Texas Instruments Incorporated

# TRF8010

## 900-MHz RF TRANSMIT DRIVER

SLWS031B – JULY 1996– REVISED MAY 1997

### description (continued)

The TRF8010 is available in a small, surface-mount, thermally enhanced TSSOP 20-pin PWP (PowerPAD™) package and is characterized for operation from  $-40^{\circ}\text{C}$  to  $85^{\circ}\text{C}$ . The PWP package has a solderable pad that can improve the package thermal performance by bonding the pad to an external thermal plane. The pad also acts as a low-inductance electrical path to ground and, for the TRF8010, must be electrically connected to the PCB ground plane as a continuation of the regular package terminals that are designated GND.

### functional block diagram

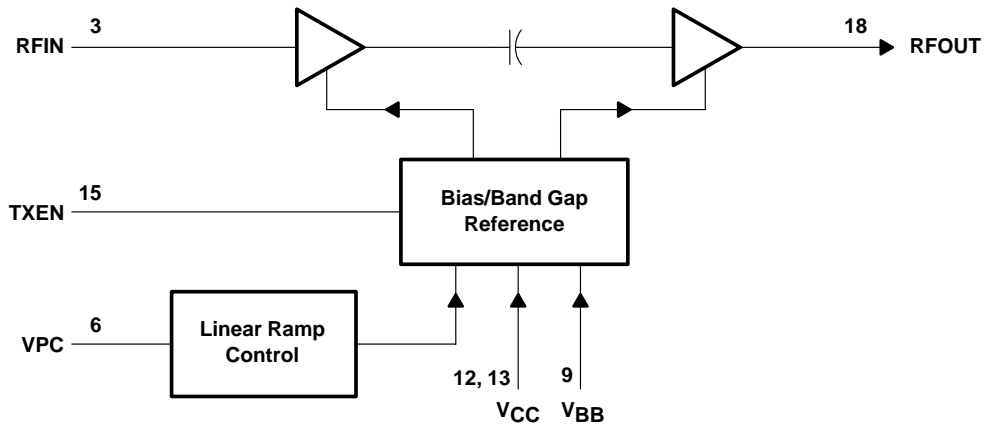

### Terminal Functions

TERMINAL NAME	TERMINAL NO.	I/O	DESCRIPTION
GND	1, 2, 4, 7, 10, 11, 14, 16, 17, 19, 20		Analog ground for all internal analog circuits. All signals are referenced to the ground terminals.
NC	5, 8		No connection. It is recommended that all NC terminals be connected to ground.
RFIN	3	I	RF input. RFIN accepts signals between 800 MHz and 1000 MHz.
RFOUT	18	O	RF output. RFOUT is an open-collector output and requires a decoupled connection to $V_{CC}$ for operation.
TXEN	15	I	Transmit enable input (digital). When TXEN is high, the output device is enabled.
$V_{BB}$	9		Control section supply voltage.
$V_{CC}$	12, 13		First stage bias.
VPC	6	I	Voltage power control. VPC is a signal between 0 V and 3 V that adjusts the output power from a typical value of $-54$ dBm to the maximum output power appropriate for the application.

PowerPAD is a trademark of Texas Instruments Incorporated.



POST OFFICE BOX 655303 • DALLAS, TEXAS 75265

# TRF8010 900-MHz RF TRANSMIT DRIVER

SLWS031B – JULY 1996 – REVISED MAY 1997

## absolute maximum ratings over operating free-air temperature range (unless otherwise noted)<sup>†</sup>

Supply voltage range, $V_{CC}$ (see Note 1)	–0.6 V to 5.6 V
Input voltage range at TXEN, VPC	–0.6 V to 5.6 V
Input power at RFIN	10 dBm
Thermal resistance, junction to case, $R_{\theta JC}$ (see Note 2)	3.5°C/W
Thermal resistance, junction to ambient, $R_{\theta JA}$ (see Note 3)	32°C/W
Continuous total power dissipation at $T_A = 25^\circ\text{C}$	3.9 W
Operating junction temperature, $T_J$	110°C
Junction temperature, $T_J$ max	150°C
Operating free-air temperature range, $T_A$	–40°C to 85°C
Storage temperature range, $T_{stg}$	–65°C to 100°C

<sup>†</sup> Stresses beyond those listed under “absolute maximum ratings” may cause permanent damage to the device. These are stress ratings only, and functional operation of the device at these or any other conditions beyond those indicated under “recommended operating conditions” is not implied. Exposure to absolute-maximum-rated conditions for extended periods may affect device reliability.

- NOTES: 1. Voltage values are with respect to GND.  
 2. No air flow and with infinite heatsink  
 3. With the thermal pad of the device soldered to a 1-ounce copper (Cu) ground plane on an FR4 board with no air flow

## recommended operating conditions

	MIN	NOM	MAX	UNIT
Supply voltage, $V_{CC}$ (see Note 1)	3		5	V
High-level input voltage at TXEN, $V_{IH}$	$V_{CC} - 0.8$			V
Low-level input voltage at TXEN, $V_{IL}$			0.8	V
Operating free-air temperature, $T_A$	–40		85	°C

NOTE 1: Voltage values are with respect to GND.

## electrical characteristics over full range of operating conditions

### supply current, $V_{CC} = 3.6\text{ V}$

PARAMETER		TEST CONDITIONS	MIN	TYP <sup>‡</sup>	MAX	UNIT
$I_{CC}$ Supply current from $V_{CC}$	Operating at maximum power out	TXEN high, VPC = 3 V		163		mA
	Operating at minimum power out	TXEN high, VPC = 0 V		7		mA

<sup>‡</sup> Typical values are at  $T_A = 25^\circ\text{C}$ .

### supply current, $V_{CC} = 4.8\text{ V}$

PARAMETER		TEST CONDITIONS	MIN	TYP <sup>‡</sup>	MAX	UNIT
$I_{CC}$ Supply current from $V_{CC}$	Operating at maximum power out	TXEN high, VPC = 3 V		155	210	mA
	Operating at minimum power out	TXEN high, VPC = 0 V		7		mA
	Power down	TXEN low, VPC = 0 V			0.05	mA

<sup>‡</sup> Typical values are at  $T_A = 25^\circ\text{C}$ .



# TRF8010

## 900-MHz RF TRANSMIT DRIVER

SLWS031B – JULY 1996– REVISED MAY 1997

### AMPS/NADC operation, $V_{CC} = 3.6\text{ V}$ , TXEN high, VPC = 3 V, $T_A = 25^\circ\text{C}$ (unless otherwise noted)

PARAMETER		TEST CONDITIONS	MIN	TYP	MAX	UNIT
Operating frequency range			824		849	MHz
$P_O$	Output power	$P_I = 0\text{ dBm}$		21		dBm
		$P_I = 0\text{ dBm}$ VPC = 0 V		-58		
Gain (small signal)		$P_I = -20\text{ dBm}$		27		dB
Power added efficiency (PAE)		$P_I = 0\text{ dBm}$		28%		
Input return loss (internally matched)		$P_I = -20\text{ dBm}$		11		dB
Output return loss (externally matched, small signal)		$P_I = -20\text{ dBm}$		11		dB
Noise power in 30 kHz bandwidth		45 MHz offset at $P_I = 0\text{ dBm}$		-97		dBm
Harmonics	$2f_0$	$P_I = 0\text{ dBm}$		-20		dBc
	$3f_0$			-50		

### GSM operation $V_{CC} = 4.8\text{ V}$ , TXEN high, VPC = 3 V, $T_A = 25^\circ\text{C}$ (unless otherwise noted)

PARAMETER		TEST CONDITIONS	MIN	TYP	MAX	UNIT
Extended GSM operating frequency range			870		925	MHz
$P_O$	Output power	$P_I = 0\text{ dBm}$	21.5	23	24.5	dBm
		$P_I = 0\text{ dBm}$ VPC = 0 V		-54		
Gain (small signal)		$P_I = -20\text{ dBm}$		28		dB
Power added efficiency (PAE)		$P_I = 0\text{ dBm}$		29%		
Input return loss (internally matched)		$P_I = -20\text{ dBm}$		11		dB
Output return loss (externally matched, small signal)		$P_I = -20\text{ dBm}$		11		dB
Harmonics	$2f_0$	$P_I = 0\text{ dBm}$		-28	-22	dBc
	$3f_0$			-40	-35	
Noise power in 30 kHz bandwidth	20 MHz above $f_0$	$P_I = 0\text{ dBm}$		-95		dBm
	10 MHz above $f_0$			-96		

### stability, AMPS/NADC and GSM operation

PARAMETER	TEST CONDITIONS	MIN	TYP	MAX	UNIT
Stability	Output VSWR $\leq 6:1$ all phases, $V_{CC} < 5.6\text{ V}$ , $P_O \leq 22\text{ dBm}$ , $P_I = 0\text{ dBm}$ , Output frequency band: 200 MHz – 1200 MHz		‡		

† VSWR = voltage standing wave ratio

‡ No parasitic oscillations (all spurious  $< -70\text{ dBc}$ )

### switching characteristics

#### AMPS/NADC and GSM operation, $V_{CC} = 3.6\text{ V}$ or $4.8\text{ V}$ , $T_A = 25^\circ\text{C}$

PARAMETER	TEST CONDITIONS	MIN	TYP	MAX	UNIT
$t_{on}$	Switching time, RF output OFF to ON TXEN = high, VPC stepped from 0 V to 3 V		1		$\mu\text{s}$
$t_{off}$	Switching time, RF output ON to OFF TXEN = high, VPC stepped from 3 V to 0 V		1		$\mu\text{s}$



POST OFFICE BOX 655303 • DALLAS, TEXAS 75265

TYPICAL CHARACTERISTICS

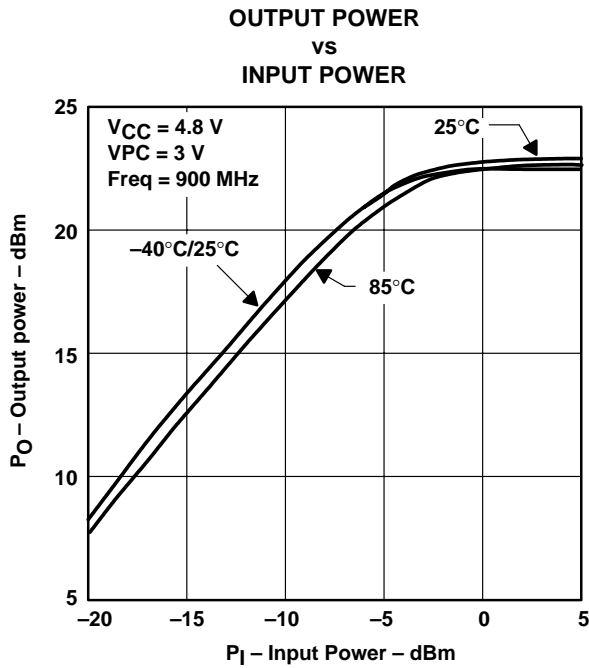

Figure 1

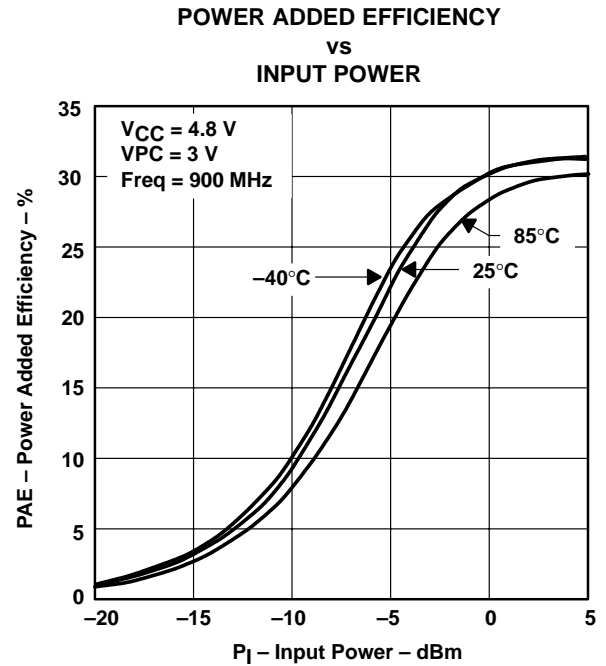

Figure 2

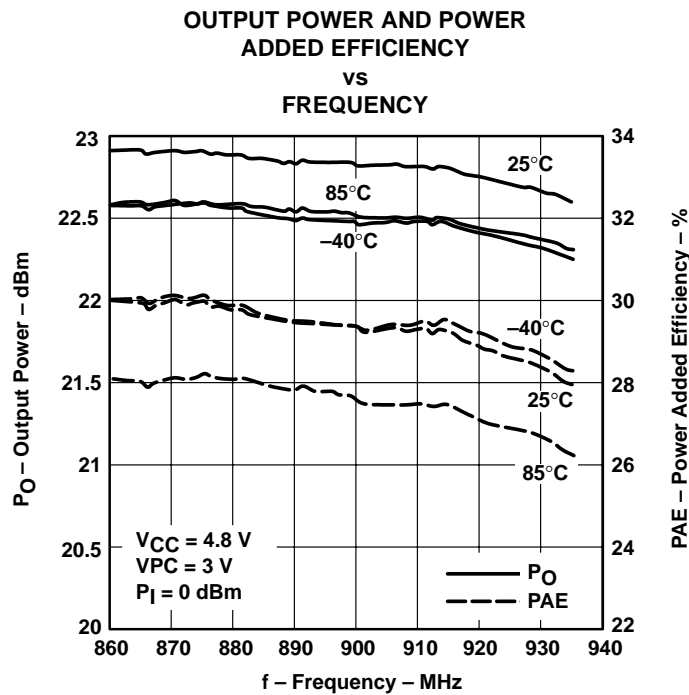
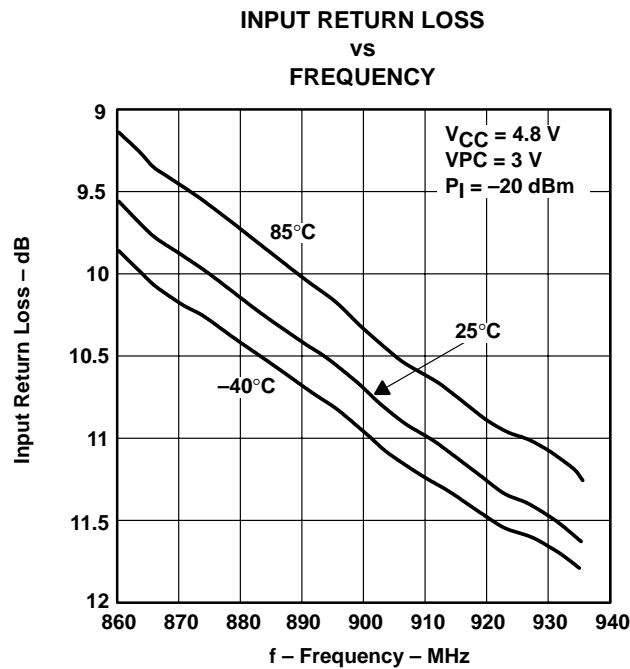
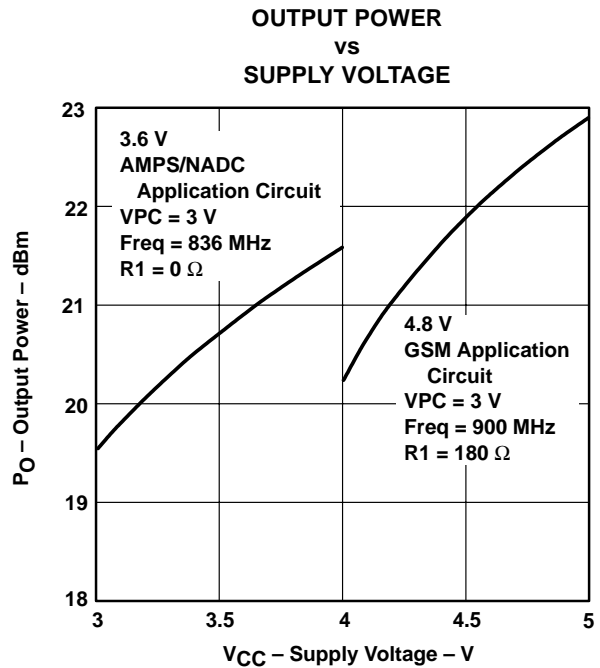
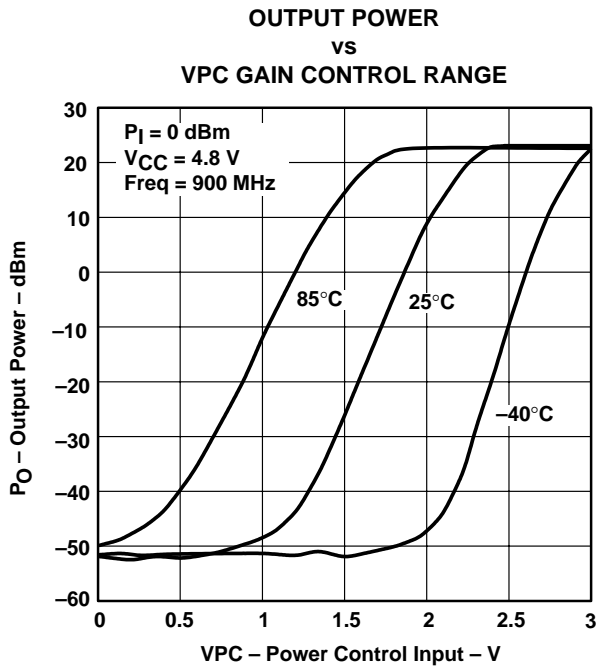

Figure 3

# TRF8010 900-MHz RF TRANSMIT DRIVER

SLWS031B – JULY 1996– REVISED MAY 1997

## TYPICAL CHARACTERISTICS



APPLICATION INFORMATION

A typical application example for AMPS/NADC cellular telephone systems is shown in Figure 7.

In all cases, a capacitor must be connected from the positive power supply to ground, as close as possible to the IC terminals for power supply bypassing. A dc-blocking capacitor is also required on the RF output. A list of components and their functions is given in Table 1.

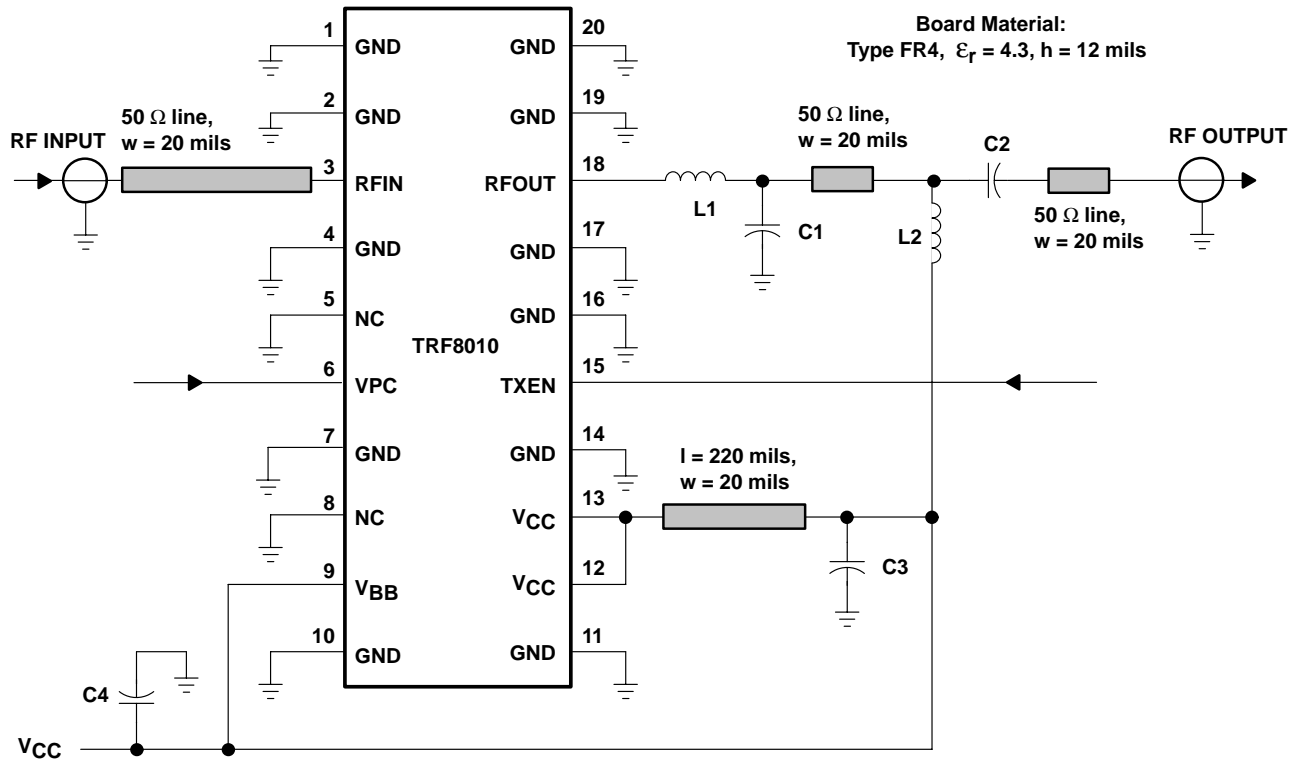

Figure 7. Typical AMPS/NADC Cellular Telephone Application

Table 1. External Component Selection (AMPS/NADC)

COMPONENT DESIGNATION	TYPICAL VALUE (AMPS/NADC)	FUNCTION
C1	3.3 pF	Output impedance matching capacitor
C2	100 pF	DC-blocking capacitor for RF output
C3	100 pF	Matching capacitor
C4	1000 pF	Power supply decoupling capacitor
L1	5.7 nH	Output impedance matching inductor
L2	100 nH	DC bias/RF choke

# TRF8010 900-MHz RF TRANSMIT DRIVER

SLWS031B – JULY 1996– REVISED MAY 1997

## APPLICATION INFORMATION

A typical application example for GSM cellular telephone systems is shown in Figure 8.

In all cases, a capacitor must be connected from the positive power supply to ground, as close as possible to the IC terminals for power supply bypassing. A dc-blocking capacitor is also required on the RF output. A list of components and their functions is given in Table 2.

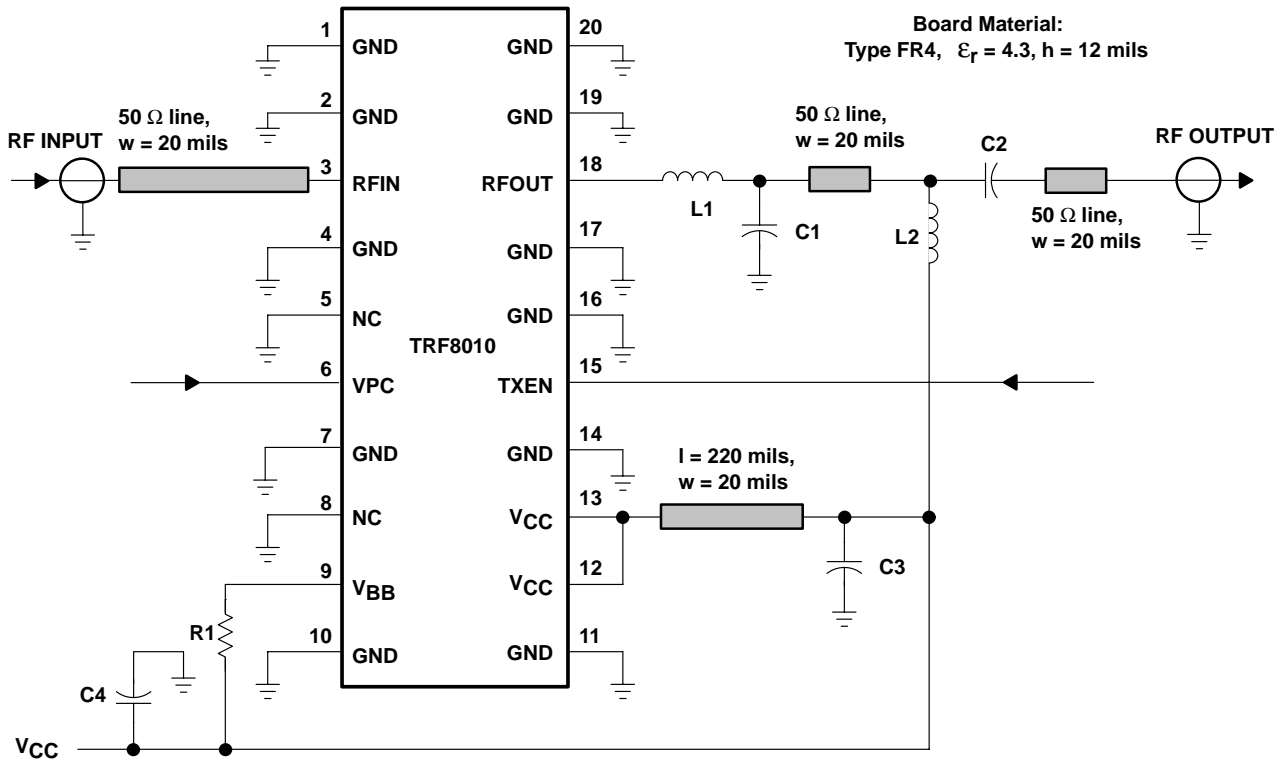

Figure 8. Typical GSM Cellular Telephone Application

Table 2. External Component Selection (GSM)

COMPONENT DESIGNATION	TYPICAL VALUE (GSM)	FUNCTION
C1	3.3 pF	Output impedance matching capacitor
C2	100 pF	DC-blocking capacitor for RF output
C3	100 pF	Matching capacitor
C4	1000 pF	Power supply decoupling capacitor
L1	6.8 nH	Output impedance matching inductor
L2	100 nH	DC bias/RF choke
R1	180 Ω	Bias supply resistor



# TRF8010 900-MHz RF TRANSMIT DRIVER

SLWS031B – JULY 1996 – REVISED MAY 1997

## MECHANICAL DATA

PWP (R-PDSO-G\*\*)

PowerPAD™ PLASTIC SMALL-OUTLINE PACKAGE

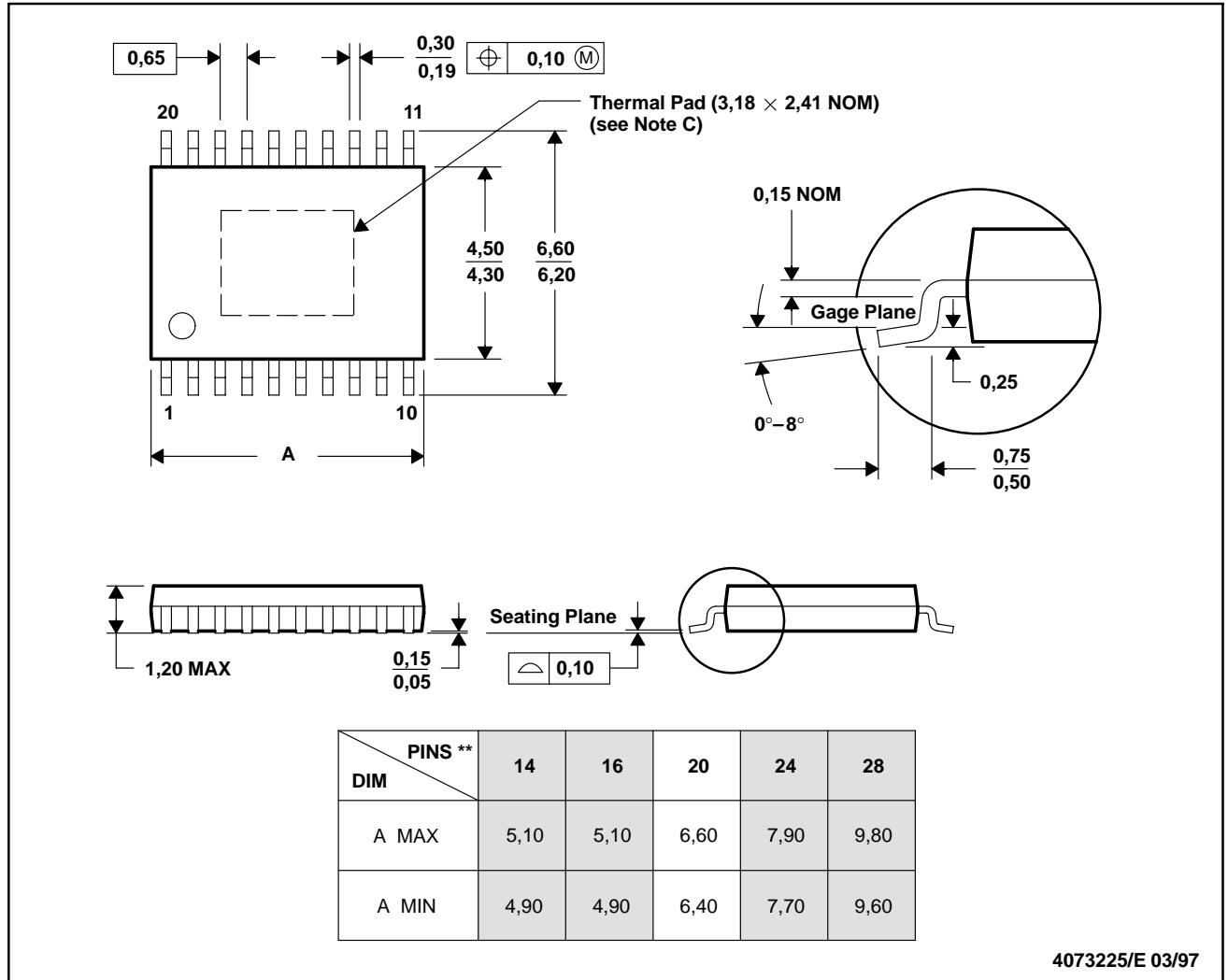

- NOTES: A. All linear dimensions are in millimeters.  
 B. This drawing is subject to change without notice.  
 C. The package thermal performance may be enhanced by bonding the thermal pad to an external thermal plane. This solderable pad is electrically and thermally connected to the backside of the die and leads 1, 10, 11, and 20.

PowerPAD is a trademark of Texas Instruments Incorporated.



POST OFFICE BOX 655303 • DALLAS, TEXAS 75265

## **IMPORTANT NOTICE**

Texas Instruments (TI) reserves the right to make changes to its products or to discontinue any semiconductor product or service without notice, and advises its customers to obtain the latest version of relevant information to verify, before placing orders, that the information being relied on is current.

TI warrants performance of its semiconductor products and related software to the specifications applicable at the time of sale in accordance with TI's standard warranty. Testing and other quality control techniques are utilized to the extent TI deems necessary to support this warranty. Specific testing of all parameters of each device is not necessarily performed, except those mandated by government requirements.

Certain applications using semiconductor products may involve potential risks of death, personal injury, or severe property or environmental damage ("Critical Applications").

**TI SEMICONDUCTOR PRODUCTS ARE NOT DESIGNED, INTENDED, AUTHORIZED, OR WARRANTED TO BE SUITABLE FOR USE IN LIFE-SUPPORT APPLICATIONS, DEVICES OR SYSTEMS OR OTHER CRITICAL APPLICATIONS.**

Inclusion of TI products in such applications is understood to be fully at the risk of the customer. Use of TI products in such applications requires the written approval of an appropriate TI officer. Questions concerning potential risk applications should be directed to TI through a local SC sales office.

In order to minimize risks associated with the customer's applications, adequate design and operating safeguards should be provided by the customer to minimize inherent or procedural hazards.

TI assumes no liability for applications assistance, customer product design, software performance, or infringement of patents or services described herein. Nor does TI warrant or represent that any license, either express or implied, is granted under any patent right, copyright, mask work right, or other intellectual property right of TI covering or relating to any combination, machine, or process in which such semiconductor products or services might be or are used.