

- Solid-State Reliability
- Supports Both Color and Monochrome Applications
- Three Independent Channels Available for Use With RGB Monitors
- Y Signal Generated From Three Independent Channels
- Clamp Pulse-Select Option
- White-Clip Function for Y Signal
- Gain Control for R, G, B, and Y
- Noise Suppression During Video-Blanking Periods

## description

The TL1051 is a bipolar monolithic integrated circuit designed for use in preprocessing three channels of TI CCD image sensors. It receives video inputs from the TI TL1593 three-channel sample-and-hold circuit and outputs three processed channel signals and a single multiplexed Y (luminance) signal. Processing functions of the TL1051 include gain, automatic gain control, clamp, white balance, and white clip.

The TL1051 is supplied in a 44-pin surface-mount plastic package and is characterized for operation from  $-20^{\circ}\text{C}$  to  $45^{\circ}\text{C}$ .

**FR PACKAGE  
(TOP VIEW)**

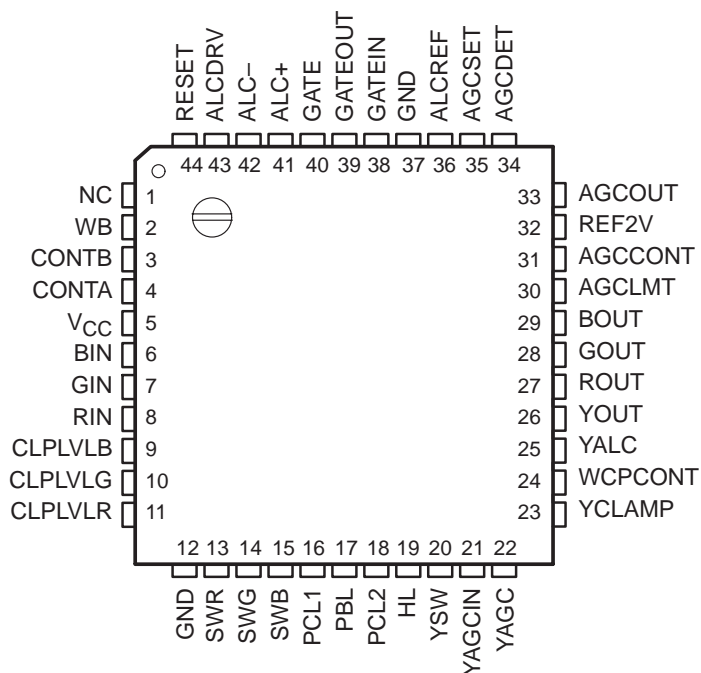

NC – No internal connection



This device contains circuits to protect its inputs and outputs against damage due to high static voltages or electrostatic fields. These circuits have been qualified to protect this device against electrostatic discharges (ESD) of up to 2 kV according to MIL-STD-883C, Method 3015; however, precautions should be taken to avoid application of any voltage higher than maximum-rated voltages to these high-impedance circuits. During storage or handling, the device leads should be shorted together or the device should be placed in conductive foam. In a circuit, unused inputs should always be connected to an appropriate logic voltage level, preferably either  $V_{CC}$  or ground. Specific guidelines for handling devices of this type are contained in the publication *Guidelines for Handling Electrostatic-Discharge-Sensitive (ESDS) Devices and Assemblies* available from Texas Instruments.

PRODUCTION DATA information is current as of publication date. Products conform to specifications per the terms of Texas Instruments standard warranty. Production processing does not necessarily include testing of all parameters.



POST OFFICE BOX 655303 • DALLAS, TEXAS 75265

Copyright © 1991, Texas Instruments Incorporated

# TL1051 VIDEO PREPROCESSOR CIRCUIT

SOCS032B – NOVEMBER 1991

## functional block diagram

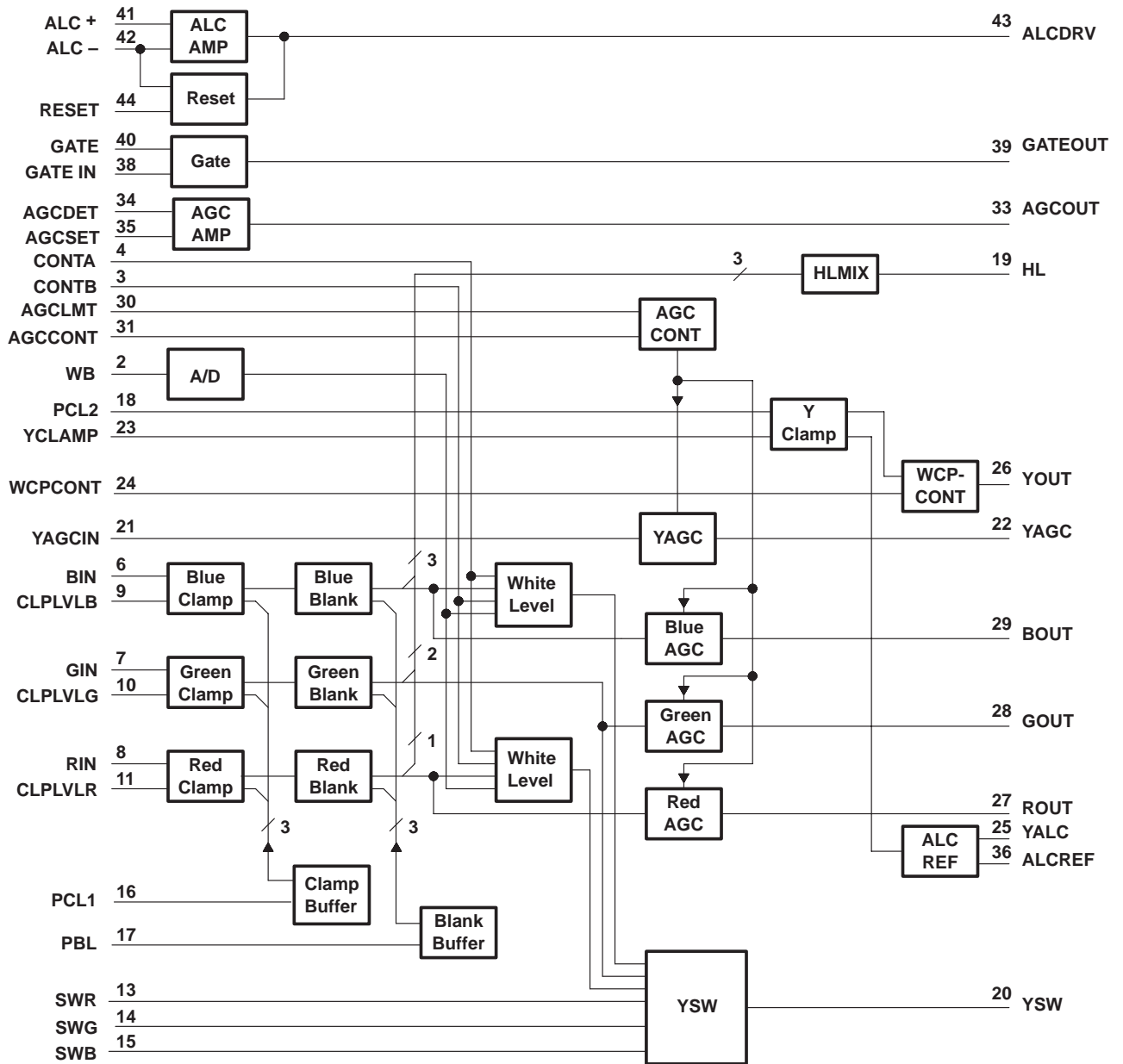

### Terminal Functions

TERMINAL		I/O	DESCRIPTION
NAME	NO.		
AGCCONT	31	I	AGC control
AGCDET	34	I	AGC detect
AGCLMT	30	I	AGC limit
AGCOUT	33	O	AGC out
AGCSET	35	I	AGC set
ALCDRV	43	O	ALC drive
ALCREF	36	O	ALC reference
ALC+	41	I	ALC noninverting input
ALC-	42	I	ALC inverting input
BIN	6	I	Blue channel in
BOUT	29	O	Blue channel out
CLPLVLB	9	I	DC clamp level – blue
CLPLVLG	10	I	DC clamp level – green
CLPLVLR	11	I	DC clamp level – red
CONTA	4	I	White balance digital control – A
CONTB	3	I	White balance digital control – B
GATE	40	I	Video gate control switch
GATEIN	38	I	Video gate in
GATEOUT	39	O	Video gate out
GIN	7	I	Green channel in
GND	12, 37		Ground
GOUT	28	O	Green channel out
HL	19	O	Highlight suppression (not used)
NC	1		No internal connection
PBL	17	I	Process blanking
PCL1	16	I	Clamp signal 1
PCL2	18	I	Clamp signal 2
REF2V	32	O	2-V reference
RESET	44	I	Reset
RIN	8	I	Red channel in
ROUT	27	O	Red channel out
SWB	15	I	Multiplex switch – blue
SWG	14	I	Multiplex switch – green
SWR	13	I	Multiplex switch – red
V <sub>CC</sub>	5		Power supply voltage
WB	2	I	White balance analog control
WCPCONT	24	I	White clip control
YAGC	22	O	YAGC out
YAGCIN	21	I	Y AGC in
YALC	25	O	Y automatic level control
YCLAMP	23	I	Y clamp
YOUT	26	O	Y signal out
YSW	20	O	Multiplexed Y out

# TL1051

## VIDEO PREPROCESSOR CIRCUIT

SOCS032B – NOVEMBER 1991

### detailed description

#### white-balance control

White balance in the monochrome mode can be adjusted with either terminal 2 (white-balance analog control) or with terminals 3 and 4 (white-balance digital controls B and A, respectively). If analog control is selected, terminals 3 and 4 should be left open and terminal 2 adjusted appropriately (see Figure 1 and Figure 2 for control characteristics). The white balance is controlled per the following table:

CONTB	CONTA	VOLTAGE LEVEL ON WB	RED	BLUE
L	L	2.4 V	-3 dB	-4 dB
L	H	2.7 V	-1 dB	-1.5 dB
H	L	3 V	1 dB	1.5 dB
H	H	3.5 V	3 dB	4 dB

#### analog inputs RIN, GIN, BIN

The TI TL1593 sample-and-hold circuit is normally the source for these inputs. The source signals should be ac coupled into the TL1051. Gain control should be used on at least two of the three channels in order to obtain an optimum balance.

#### clamp level

Input terminals 9, 10, and 11 (CLPLVLB, CLPLVLG, and CLPLVLR, respectively) should initially be set at approximately 2 V dc. The levels should then be balanced so that clock feedthrough on terminal 20 (YSW) is minimized under dark conditions.

#### multiplexed switching

Input terminals 13, 14, and 15 (SWR, SWG, and SWB, respectively) are the TTL-level signals used to multiplex the three channels.

#### clamping and process blanking

Input terminals 16, 17, and 18 (PCL1, PBL, and PCL2) are used for TTL clamp and blank signals. The dark references are clamped by the PCL1 signal. Unwanted noise in the video signal is eliminated by the PBL signal. The Y signal can then be reclamped with the PCL2 signal.

Depending on the application, gain and automatic gain control (AGC) may or may not be selected. The following descriptions cover both selections.

#### YSW

YSW output (terminal 20): Fast sampling of the video input signals with the TTL multiplex signals generates this high-bandwidth output without adjustable gain or AGC.

#### gain and AGC selected

YAGCIN input (terminal 21): If gain or AGC operation is selected, the YSW output (terminal 20) should be directly connected to YAGCIN.

YAGC output (terminal 22): The multiplexed signal with controllable gain (controlled by the AGCCONT input) is available at this terminal if terminals 20 (YSW) and 21 (YAGCIN) are connected. If further signal processing is desired, this terminal should be ac coupled to terminal 23 (YCLAMP).

YCLAMP input (terminal 23): The Y signal from YAGC can be reclamped at this point by applying a wider clamp pulse to terminal 18 (PCL2).

WCPCONT input (terminal 24): A dc voltage applied to this white clip control input causes the white clip function to be performed on the Y signal. See Figure 4 for the clip control characteristics.

YALC output (terminal 25): If either AGC or automatic level control (ALC) is selected, the Y signal at this point should be fed back to either the ALC or AGC block.

YOUT output (terminal 26): The white-clipped Y signal is available at this output.



### **analog output channels**

Terminals 27, 28, and 29 (ROUT, GOUT, and BOUT) are the individual analog output signals used in RGB color applications. Their gain can be affected by the control voltage applied to terminal 31 (AGCCONT).

### **AGC section**

The AGC amplifier is a high-gain amplifier that requires an appropriate feedback network.

AGCLMT input (terminal 30): A dc voltage applied to this terminal limits the amount of gain for R, G, B, and Y.

AGCCONT input (terminal 31): A dc voltage applied to this terminal sets the gain (see Figure 3). It is also possible to build a feedback network and obtain AGC action. In this case, the video signal is fed back through AGCCONT.

REF2V output (terminal 32): This terminal provides a 2-V reference output.

AGCOUT output (terminal 33): This is the output from the AGC block.

AGCDET input (terminal 34): Video from terminal 26 (YOUT) can be applied to this node to obtain feedback action.

AGCSET input (terminal 35): A dc voltage applied to this terminal sets the gain for AGC action.

### **gate section**

GATEIN input (terminal 38): If a gating function is desired, video from the YOUT output (terminal 26) can be applied to this terminal.

GATEOUT output (terminal 39): Video is passed from GATEIN to GATEOUT if GATE (terminal 40) is low. If GATE is high, GATEOUT is in the high-impedance state.

GATE input (terminal 40): A TTL signal can be applied to this input to control the active video (see the description of the GATEOUT terminal above).

### **ALC section**

An amplifier similar to that in the AGC section is available for use as an integrator. If used, a capacitor should be connected from the ALC-input (terminal 42) to the ALCDRV output (terminal 43). A reset switch is available at the RESET input (terminal 44). The ALC amplifier is a high-gain amplifier requiring an appropriate feedback network.

# TL1051

## VIDEO PREPROCESSOR CIRCUIT

SOCS032B – NOVEMBER 1991

### absolute maximum ratings over operating free-air temperature range (unless otherwise noted)†

Supply voltage, $V_{CC}$ (see Note 1)	8 V
Input voltage range, $V_I$	8 V
Operating free-air temperature range, $T_A$	–25°C to 75°C
Storage temperature range	–40°C to 125°C
Lead temperature 1,6 mm (1/16 inch) from case for 10 seconds	260°C

† Stresses beyond those listed under “absolute maximum ratings” may cause permanent damage to the device. These are stress ratings only, and functional operation of the device at these or any other conditions beyond those indicated under “recommended operating conditions” is not implied. Exposure to absolute-maximum-rated conditions for extended periods may affect device reliability.

NOTE 1: All voltage values are with respect to the GND terminal.

### recommended operating conditions

		MIN	NOM	MAX	UNIT
Supply voltage, $V_{CC}$		4.8	5	5.2	V
Input voltage, $V_I$	RIN, GIN, BIN	250			mV
	WB	0	3.05	5	V
	CLPLVLR, CLPLVLG, CLPLVLB	2			
	WCPCONT, AGCLMT, AGCCONT	0	3	5	
	AGCDET, AGCSET	3			
High-level input voltage, $V_{IH}$	3.5			V	
Low-level input voltage, $V_{IL}$	0.4			V	
Operating free-air temperature, $T_A$		–20		45	°C

### electrical characteristics over recommended operating free-air temperature range (unless otherwise noted)

#### all sections

PARAMETER		TEST CONDITIONS	MIN	TYP‡	MAX	UNIT
$I_{CC}$	Supply current	$V_{CC} = 5\text{ V}$		40	50	mA

#### Y-switch section

PARAMETER		TEST CONDITIONS	MIN	TYP‡	MAX	UNIT
White-clip level (see Note 2)			400%			
Gate-pulse impedance	SWB, SWG,		5			k $\Omega$
Gate-pulse capacitance	SWR		10			pF

#### clamp section

PARAMETER		TEST CONDITIONS	MIN	TYP‡	MAX	UNIT
Clamp-pulse current	PCL1		–0.2		0.2	mA
Clamp resistance	BIN, GIN, RIN	PCL1 = 1 $\mu\text{s}$	30			$\Omega$
Clamp-pulse input capacitance	PCL1		30			pF
Noise rejection	PCL1 to YSW		30			dB

‡ All typical values are at  $T_A = 25^\circ\text{C}$ .

NOTE 2: 250 mV = 100%.



# TL1051 VIDEO PREPROCESSOR CIRCUIT

SOCS032B – NOVEMBER 1991

**electrical characteristics over recommended operating free-air temperature range (unless otherwise noted) (continued)**

### blanking section

PARAMETER		TEST CONDITIONS	MIN	MAX	UNIT
Blanking-pulse current	PBL		-0.2	0.2	mA
Blanking-pulse input capacitance	PBL			30	pF
Noise rejection	PBL to YSW		30		dB

### white-balance section

PARAMETER		TEST CONDITIONS	MIN	MAX	UNIT
Input current	WB		-10	10	μA
Red channel gain	RIN, WB to YSW	WB = 3.5 V	2.6	3.5	dB
		WB = 3 V	0.5	1.5	
		WB = 2.7 V	-1.7	-0.6	
		WB = 2.4 V	-3.7	-2.7	
Blue channel gain	BIN, WB to YSW	WB = 3.5 V	-4.4	-3.1	dB
		WB = 3 V	-1.9	-0.8	
		WB = 2.7 V	1	1.9	
		WB = 2.4 V	3.5	4.5	

### AGC section

PARAMETER		TEST CONDITIONS	MIN	TYP†	MAX	UNIT
Gain delta between R, G, B channels			-0.5	0	0.5	dB
Gain control	RIN, GIN, BIN to ROUT, GOUT, BOUT, YAGC	AGCCONT = 1.5 V	-1	0	1	dB
		AGCCONT = 4.5 V	11.5	12.5	14.5	
AGC limit 1		AGCLMT = 0			0	dB
AGC limit 2		AGCLMT = 5 V	12.5			
RGB bandwidth	RIN, GIN, BIN to ROUT, GOUT, BOUT	AGCCONT = 2.5 V (AGC on)	2.9	3.6	MHz	
		AGCCONT = 0.5 V (AGC off)	3	5.1		
	RIN, GIN, BIN to YAGC	AGCCONT = 2.5 V (AGC on)	3.4	4.2		
		AGCCONT = 0.5 V (AGC off)	5	6.2		
Output impedance	ROUT, GOUT, BOUT			150	Ω	

### Y-clamp section

PARAMETER		TEST CONDITIONS	MIN	TYP†	MAX	UNIT
Clamp pulse current	PCL2		-0.2		0.2	mA
Clamp pulse capacitance	PCL2				50	pF

### white-clip section

PARAMETER		TEST CONDITIONS	MIN	TYP†	MAX	UNIT
White-clip point	YCL to YOUT	See Note 3	400%			
Knee point 1		WCPCONT open, See Note 3		118%		
Knee point 2		WCPCONT = 3 V, See Note 3	176%	236%		
Knee point 3		WCPCONT = 2 V, See Note 3		35%	59%	
Knee compression ratio			13.5	15.5	17.5	dB
Output impedance	YOUT				100	Ω

† All typical values are at  $T_A = 25^\circ\text{C}$ .

NOTE 3: 340 mV = 100%.



# TL1051

## VIDEO PREPROCESSOR CIRCUIT

SOCS032B – NOVEMBER 1991

electrical characteristics over recommended operating free-air temperature range (unless otherwise noted) (continued)

### ALC-clip section

PARAMETER		TEST CONDITIONS	MIN	TYP†	MAX	UNIT
V <sub>O</sub>	Output voltage	V <sub>CC</sub> = 4.8 V to 5.2 V	2.6	2.8	3	V
	Clip level		340			mV
	Output impedance	ALCREF, YALC	100			Ω

### AGCDET section (see Note 4)

PARAMETER		TEST CONDITIONS	MIN	TYP†	MAX	UNIT
Gain	AGCDET, AGCOUT		60			dB
AGC setpoint 1	AGCDET, AGCSET, AGCOUT	AGCSET = 3.5 V	41%			
AGC setpoint 2		AGCSET = 1.5 V	12%			
AGC setpoint 3		AGCSET open	24%			

### ALC-amplifier section

PARAMETER		TEST CONDITIONS	MIN	TYP†	MAX	UNIT
Maximum output voltage	ALCDRV		3.5			V
Minimum output voltage	ALCDRV		0.5			V
V <sub>IO</sub>	Input offset voltage	ALC+, ALC-	-8	0	8	mV
I <sub>B</sub>	Input bias current	ALC+, ALC-	200			nA
I <sub>I</sub>	Input current	RESET	-0.5			mA
Gain	ALC+, ALC-, ALCDRV		60			dB

† All typical values are at T<sub>A</sub> = 25° C.

NOTE 4: The YAGC output is 100% when the YAGCIN input = 250 mV.

operating characteristics over recommended operating temperature range (unless otherwise noted)

### Y-switch section

PARAMETER		TEST CONDITIONS	MIN	TYP	MAX	UNIT
Switching frequency, RIN, GIN, BIN to YSW		WB = 0 V to V <sub>CC</sub>	8	10		MHz
t <sub>pd</sub>	RIN or BIN to YSW		20		30	ns
	GIN to YSW		10		20	
	SWR, SWG, or SWB to YSW		5			
SWR, SWG, SWB acquisition time			20			ns
YSW output settling time			30			ns

### clamp section

PARAMETER		TEST CONDITIONS	MIN	MAX	UNIT
t <sub>pd</sub>	PCL1 to YSW		100		ns

### blanking section

PARAMETER		TEST CONDITIONS	MIN	MAX	UNIT
t <sub>pd</sub>	PBL to YSW		150		ns





# TL1051 VIDEO PREPROCESSOR CIRCUIT

SOCS032B – NOVEMBER 1991

**operating characteristics over recommended operating temperature range (unless otherwise noted) (continued)**

**Y-clamp section**

PARAMETER		TEST CONDITIONS	MIN	MAX	UNIT
$t_{pd}$	PCL2 to YOUT			500	ns

**white-clip section**

PARAMETER		TEST CONDITIONS	MIN	TYP	MAX	UNIT
Switching frequency, YCL to YOUT		WCPCONT open	6	8		MHz

**ALC-clip section**

PARAMETER		TEST CONDITIONS	MIN	MAX	UNIT
Switching frequency, YCL to YALC			2		MHz



# TL1051 VIDEO PREPROCESSOR CIRCUIT

SOCS032B – NOVEMBER 1991

## TYPICAL CHARACTERISTICS

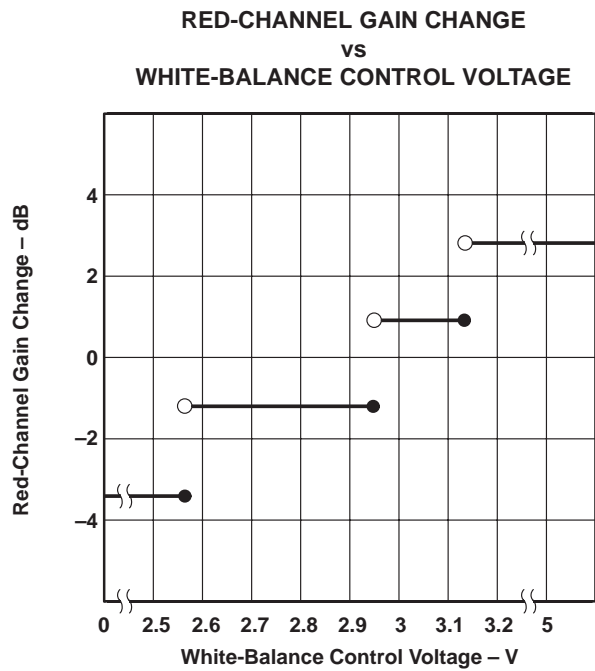

Figure 1

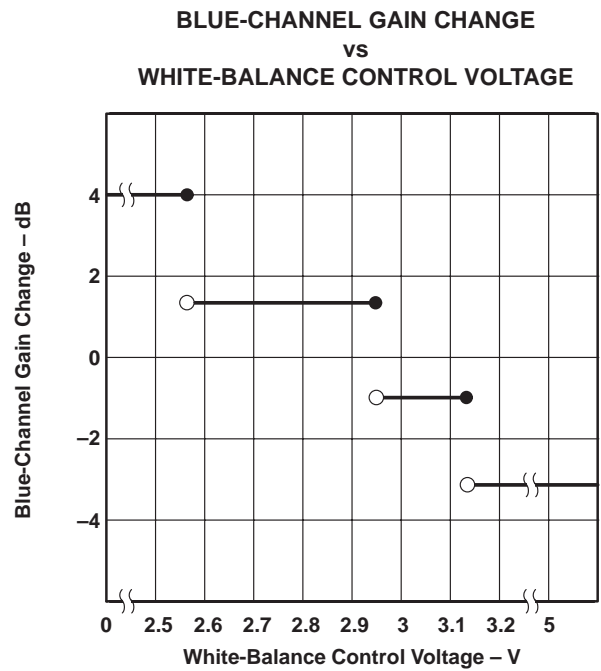

Figure 2

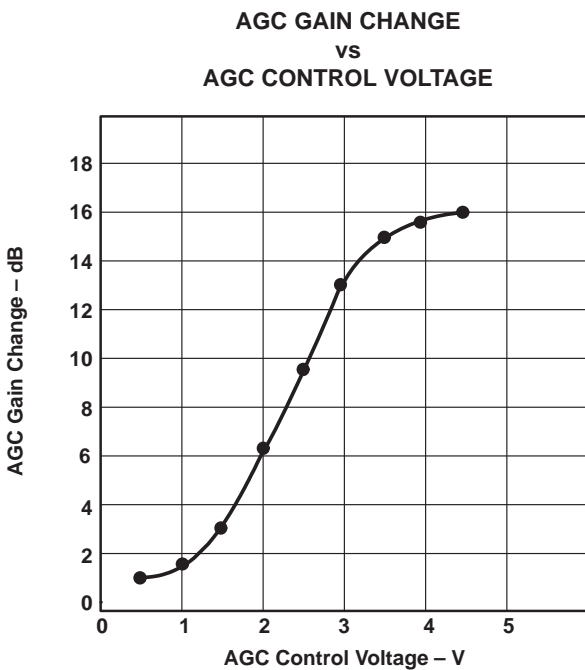

Figure 3

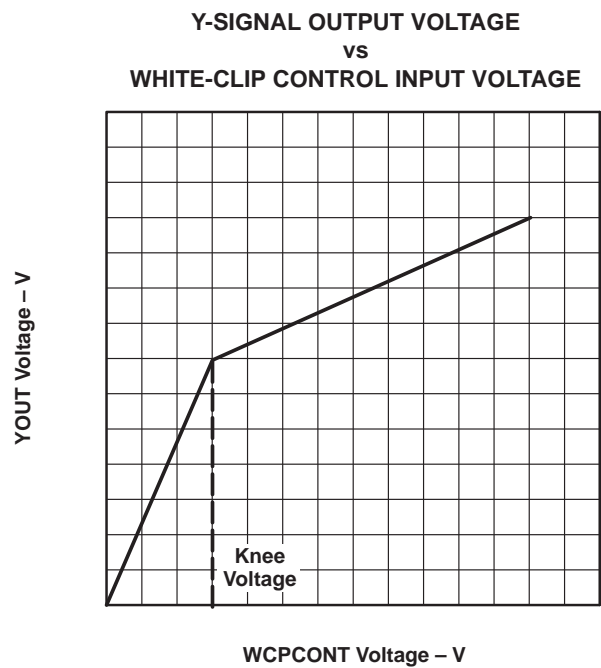
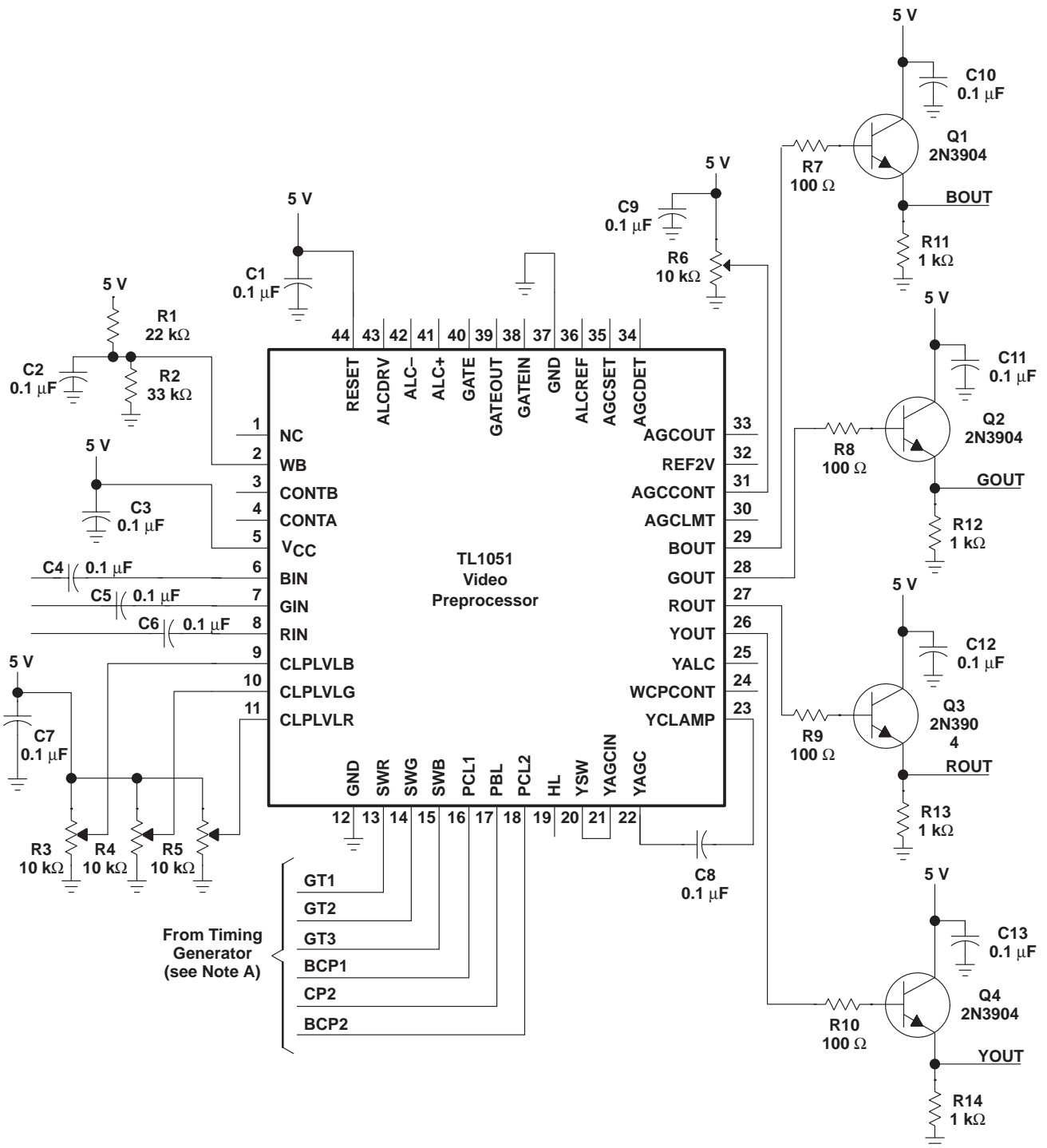

Figure 4

APPLICATION INFORMATION



NOTE A: This application circuit shows TTL signals originating from the TI SN28835 1/2-Inch NTSC Timer. However, the TL1051 video preprocessor interfaces equally well with a TI TMS3471C 2/3-Inch NTSC timer, a TI SN28837 1/2-Inch PAL timer, or a user-defined timing generator.

Figure 5. Typical Application Circuit

# TL1051 VIDEO PREPROCESSOR CIRCUIT

SOCS032B – NOVEMBER 1991

## MECHANICAL DATA

FR/S-PDFP-G44

PLASTIC QUAD FLATPACK

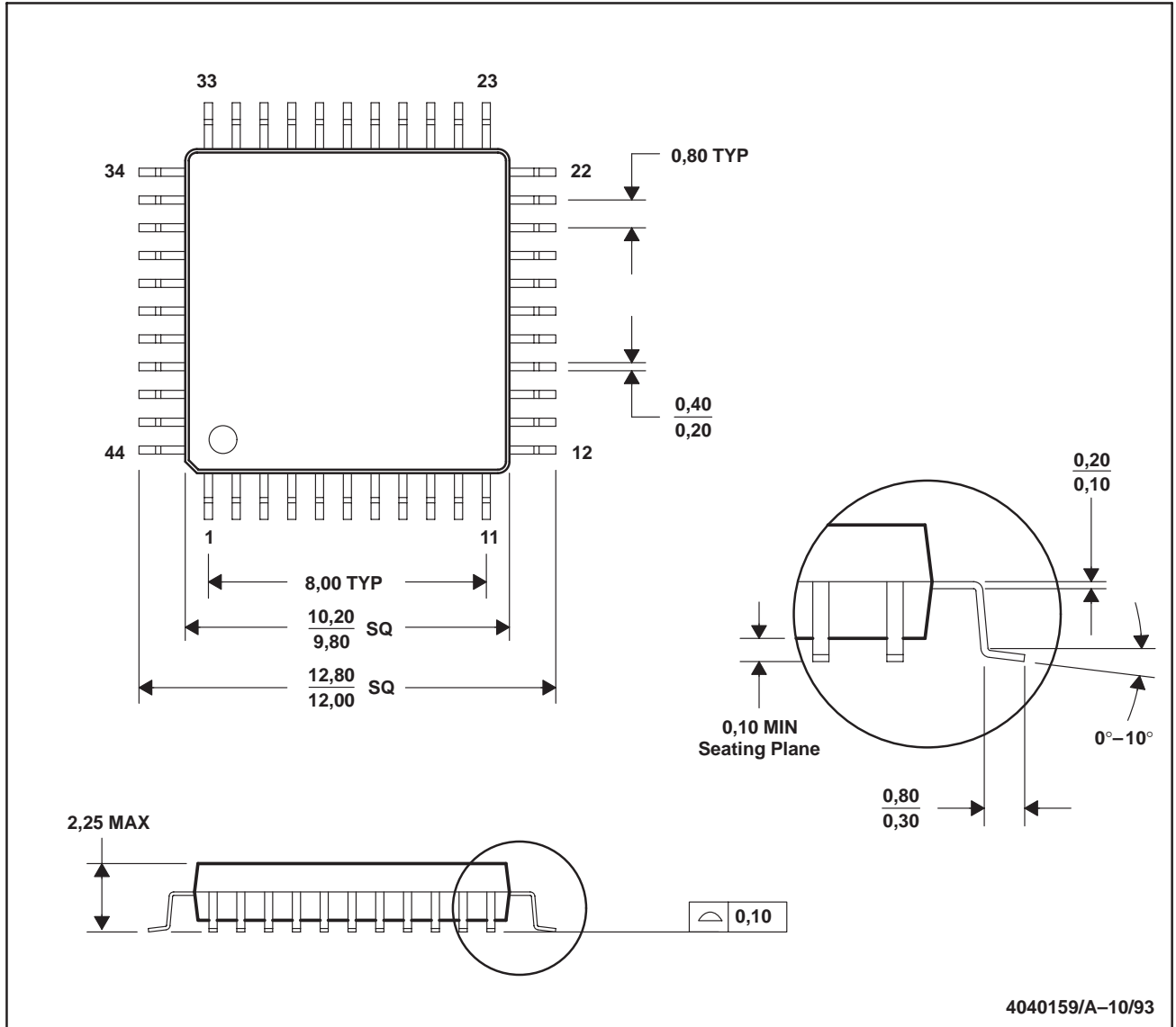

- NOTES: A. All linear dimensions are in millimeters.  
B. This drawing is subject to change without notice.

## IMPORTANT NOTICE

Texas Instruments and its subsidiaries (TI) reserve the right to make changes to their products or to discontinue any product or service without notice, and advise customers to obtain the latest version of relevant information to verify, before placing orders, that information being relied on is current and complete. All products are sold subject to the terms and conditions of sale supplied at the time of order acknowledgement, including those pertaining to warranty, patent infringement, and limitation of liability.

TI warrants performance of its semiconductor products to the specifications applicable at the time of sale in accordance with TI's standard warranty. Testing and other quality control techniques are utilized to the extent TI deems necessary to support this warranty. Specific testing of all parameters of each device is not necessarily performed, except those mandated by government requirements.

CERTAIN APPLICATIONS USING SEMICONDUCTOR PRODUCTS MAY INVOLVE POTENTIAL RISKS OF DEATH, PERSONAL INJURY, OR SEVERE PROPERTY OR ENVIRONMENTAL DAMAGE ("CRITICAL APPLICATIONS"). TI SEMICONDUCTOR PRODUCTS ARE NOT DESIGNED, AUTHORIZED, OR WARRANTED TO BE SUITABLE FOR USE IN LIFE-SUPPORT DEVICES OR SYSTEMS OR OTHER CRITICAL APPLICATIONS. INCLUSION OF TI PRODUCTS IN SUCH APPLICATIONS IS UNDERSTOOD TO BE FULLY AT THE CUSTOMER'S RISK.

In order to minimize risks associated with the customer's applications, adequate design and operating safeguards must be provided by the customer to minimize inherent or procedural hazards.

TI assumes no liability for applications assistance or customer product design. TI does not warrant or represent that any license, either express or implied, is granted under any patent right, copyright, mask work right, or other intellectual property right of TI covering or relating to any combination, machine, or process in which such semiconductor products or services might be or are used. TI's publication of information regarding any third party's products or services does not constitute TI's approval, warranty or endorsement thereof.