

18-Bit Registers

Features

- FCT-E speed at 4.4 ns
- Power-off disable outputs permits live insertion
- Edge-rate control circuitry for significantly improved noise characteristics
- Typical output skew < 250 ps
- ESD > 2000V
- TSSOP (19.6-mil pitch) and SSOP (25-mil pitch) packages
- Industrial temperature range of -40°C to $+85^{\circ}\text{C}$
- $V_{CC} = 5V \pm 10\%$

CY74FCT16823T Features:

- 64 mA sink current, 32 mA source current
- Typical V_{OLP} (ground bounce) < 1.0V at $V_{CC} = 5V$, $T_A = 25^{\circ}\text{C}$

CY74FCT162823T Features:

- **Balanced 24 mA output drivers**
- **Reduced system switching noise**
- **Typical V_{OLP} (ground bounce) < 0.6V at $V_{CC} = 5V$, $T_A = 25^{\circ}\text{C}$**

Functional Description

The CY74FCT16823T and the CY74FCT162823T 18-bit bus interface registers are designed for use in high-speed, low-power systems needing wide registers and parity. 18-bit operation is achieved by connecting the control lines of the two 9-bit registers. Flow-through pinout and small shrink packaging aids in simplifying board layout. The outputs are designed with a power-off disable feature to allow live insertion of boards.

The CY74FCT16823T is ideally suited for driving high-capacitance loads and low-impedance backplanes.

The CY74FCT162823T has 24-mA balanced output drivers with current limiting resistors in the outputs. This reduces the need for external terminating resistors and provides for minimal undershoot and reduced ground bounce. The CY74FCT162823T is ideal for driving transmission lines.

Logic Block Diagrams

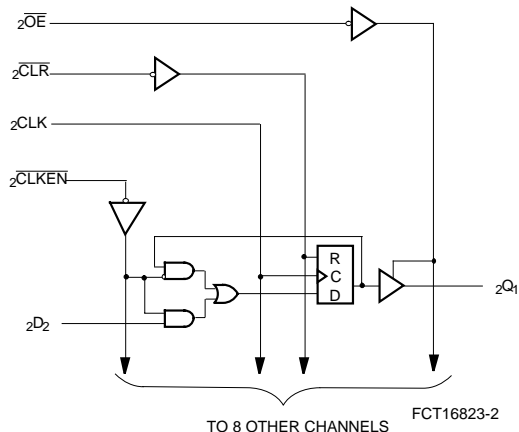
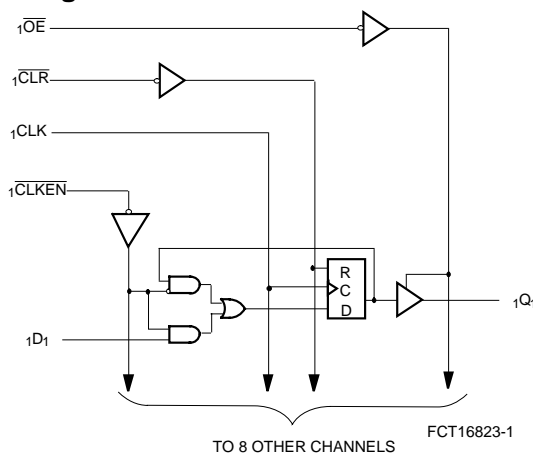

Pin Configuration SSOP/TSSOP Top View

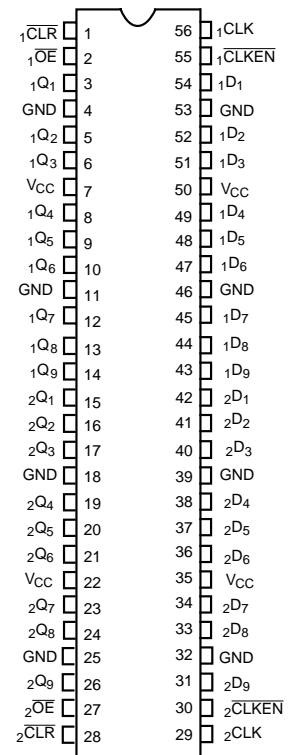

FCT16823-3

Pin Description

Name	Description
D	Data Inputs
CLK	Clock Inputs
$\overline{\text{CLKEN}}$	Clock Enable Inputs (Active LOW)
$\overline{\text{CLR}}$	Asynchronous Clear Inputs (Active LOW)
$\overline{\text{OE}}$	Output Enable Inputs (Active LOW)
Q	Three-State Outputs

Function Table^[1]

Inputs						Outputs
$\overline{\text{OE}}$	CLR	$\overline{\text{CLKEN}}$	CLK	D	Q	Function
H	X	X	X	X	Z	High Z
L	L	X	X	X	L	Clear
L	H	H	X	X	Q ^[2]	Hold
H	H	L	\lrcorner	L	Z	Load
H	H	L	\lrcorner	H	Z	
L	H	L	\lrcorner	L	L	
L	H	L	\lrcorner	H	H	

Maximum Ratings^[3, 4]

(Above which the useful life may be impaired. For user guidelines, not tested.)

Storage Temperature -55°C to +125°C
 Ambient Temperature with
 Power Applied -55°C to +125°C
 DC Input Voltage -0.5V to +7.0V
 DC Output Voltage -0.5V to +7.0V
 DC Output Current
 (Maximum Sink Current/Pin) -60 to +120 mA

Power Dissipation 1.0W
 Static Discharge Voltage >2001V
 (per MIL-STD-883, Method 3015)

Operating Range

Range	Ambient Temperature	V _{CC}
Industrial	-40°C to +85°C	5V ± 10%

Notes:

- H = HIGH Voltage Level.
 L = LOW Voltage Level.
 X = Don't Care.
 Z = HIGH Impedance.
 \lrcorner = LOW-to-HIGH transition.
- Output level before indicated steady-state input conditions were established.
- Operation beyond the limits set forth may impair the useful life of the device. Unless otherwise noted, these limits are over the operating free-air temperature range.
- Unused inputs must always be connected to an appropriate logic voltage level, preferably either V_{CC} or ground.

Electrical Characteristics Over the Operating Range

Parameter	Description	Test Conditions	Min.	Typ. ^[5]	Max.	Unit
V _{IH}	Input HIGH Voltage		2.0			V
V _{IL}	Input LOW Voltage				0.8	V
V _H	Input Hysteresis ^[6]			100		mV
V _{IK}	Input Clamp Diode Voltage	V _{CC} =Min., I _{IN} =-18 mA		-0.7	-1.2	V
I _{IH}	Input HIGH Current	V _{CC} =Max., V _I =V _{CC}			±1	μA
I _{IL}	Input LOW Current	V _{CC} =Max., V _I =GND			±1	μA
I _{OZH}	High Impedance Output Current (Three-State Output pins)	V _{CC} =Max., V _{OUT} =2.7V			±1	μA
I _{OZL}	High Impedance Output Current (Three-State Output pins)	V _{CC} =Max., V _{OUT} =0.5V			±1	μA
I _{OS}	Short Circuit Current ^[7]	V _{CC} =Max., V _{OUT} =GND	-80	-140	-200	mA
I _O	Output Drive Current ^[7]	V _{CC} =Max., V _{OUT} =2.5V	-50		-180	mA
I _{OFF}	Power-Off Disable	V _{CC} =0V, V _{OUT} ≤4.5V ^[8]			1	μA

Output Drive Characteristics for CY74FCT16823T

Parameter	Description	Test Conditions	Min.	Typ. ^[5]	Max.	Unit
V _{OH}	Output HIGH Voltage	V _{CC} =Min., I _{OH} =-3 mA	2.5	3.5		V
		V _{CC} =Min., I _{OH} =-15 mA	2.4	3.5		
		V _{CC} =Min., I _{OH} =-32 mA	2.0	3.0		
V _{OL}	Output LOW Voltage	V _{CC} =Min., I _{OL} =64 mA		0.2	0.55	V

Output Drive Characteristics for CY74FCT162823T

Parameter	Description	Test Conditions	Min.	Typ. ^[5]	Max.	Unit
I _{ODL}	Output LOW Voltage ^[7]	V _{CC} =5V, V _{IN} =V _{IH} or V _{IL} , V _{OUT} =1.5V	60	115	150	mA
I _{ODH}	Output HIGH Voltage ^[7]	V _{CC} =5V, V _{IN} =V _{IH} or V _{IL} , V _{OUT} =1.5V	-60	-115	-150	mA
V _{OH}	Output HIGH Voltage	V _{CC} =Min., I _{OH} =-24 mA	2.4	3.3		V
V _{OL}	Output LOW Voltage	V _{CC} =Min., I _{OL} =24 mA		0.3	0.55	V

Capacitance^[9] (T_A = +25°C, f = 1.0 MHz)

Parameter	Description	Test Conditions	Typ. ^[5]	Max.	Unit
C _{IN}	Input Capacitance	V _{IN} = 0V	4.5	6.0	pF
C _{OUT}	Output Capacitance	V _{OUT} = 0V	5.5	8.0	pF

Notes:

5. Typical values are at V_{CC}= 5.0V, T_A= +25°C ambient.
6. This input is specified but not tested.
7. Not more than one output should be shorted at a time. Duration of short should not exceed one second. The use of high-speed test apparatus and/or sample and hold techniques are preferable in order to minimize internal chip heating and more accurately reflect operational values. Otherwise prolonged shorting of a high output may raise the chip temperature well above normal and thereby cause invalid readings in other parametric tests. In any sequence of parameter tests, I_{OS} tests should be performed last.
8. Tested at +25°C.
9. This parameter is specified but not tested.

Power Supply Characteristics

Parameter	Description	Test Conditions ^[10]		Min.	Typ. ^[5]	Max.	Unit
I_{CC}	Quiescent Power Supply Current	$V_{CC}=\text{Max.}$	$V_{IN}\leq 0.2V$ $V_{IN}\geq V_{CC}-0.2V$	—	5	500	μA
ΔI_{CC}	Quiescent Power Supply Current (TTL inputs HIGH)	$V_{CC}=\text{Max.}$	$V_{IN}=3.4V$ ^[11]	—	0.5	1.5	mA
I_{CCD}	Dynamic Power Supply Current ^[12]	$V_{CC}=\text{Max.}$, One Input Toggling, 50% Duty Cycle, Outputs Open, $\overline{OE}=\text{CLKEN}=\text{GND}$	$V_{IN}=V_{CC}$ or $V_{IN}=\text{GND}$	—	75	120	$\mu A/\text{MHz}$
I_C	Total Power Supply Current ^[13]	$V_{CC}=\text{Max.}$, $f_0=10\text{ MHz}$, 50% Duty Cycle, Outputs Open, One Bit Toggling, $\overline{OE}=\text{CLKEN}=\text{GND}$ at $f_1=5\text{ MHz}$	$V_{IN}=V_{CC}$ or $V_{IN}=\text{GND}$	—	0.8	1.7	mA
			$V_{IN}=3.4V$ or $V_{IN}=\text{GND}$	—	1.3	3.2	
		$V_{CC}=\text{Max.}$, at $f_1=2.5\text{ MHz}$, 50% Duty Cycle, Outputs Open, Eighteen Bits Toggling, $\overline{OE}=\text{CLKEN}=\text{GND}$ $f_0=10\text{ MHz}$	$V_{IN}=V_{CC}$ or $V_{IN}=\text{GND}$	—	4.2	7.1 ^[14]	
			$V_{IN}=3.4V$ or $V_{IN}=\text{GND}$	—	9.2	22.1 ^[14]	

Notes:

10. For conditions shown as Max. or Min., use appropriate value specified under Electrical Characteristics for the applicable device type.
11. Per TTL driven input ($V_{IN}=3.4V$); all other inputs at V_{CC} or GND.
12. This parameter is not directly testable, but is derived for use in Total Power Supply calculations.
13. $I_C = I_{\text{QUIESCENT}} + I_{\text{INPUTS}} + I_{\text{DYNAMIC}}$
 $I_C = I_{CC} + \Delta I_{CC} D_H N_T + I_{CCD} (f_0/2 + f_1 N_1)$
 I_{CC} = Quiescent Current with CMOS input levels
 ΔI_{CC} = Power Supply Current for a TTL HIGH input ($V_{IN}=3.4V$)
 D_H = Duty Cycle for TTL inputs HIGH
 N_T = Number of TTL inputs at D_H
 I_{CCD} = Dynamic Current caused by an input transition pair (HLH or LHL)
 f_0 = Clock frequency for registered devices, otherwise zero
 f_1 = Input signal frequency
 N_1 = Number of inputs changing at f_1
 All currents are in milliamps and all frequencies are in megahertz.
14. Values for these conditions are examples of the I_{CC} formula. These limits are specified but not tested.

Switching Characteristics Over the Operating Range^[15]

Parameter	Description	Condition ^[16]	CY74FCT16823AT CY74FCT162823AT		Unit	Fig.No. ^[16]
			Min.	Max.		
t _{PLH} t _{PHL}	Propagation Delay CLK to Q	C _L =50 pF R _L =500Ω	1.5	10.0	ns	1, 5
		C _L =300 pF ^[17] R _L =500Ω	1.5	20.0		
t _{PHL}	Propagation Delay $\overline{\text{CLR}}$ to Q	C _L =50 pF R _L =500Ω	1.5	14.0	ns	1, 5
t _{PZH} t _{PZL}	Output Enable Time $\overline{\text{OE}}$ to Q	C _L =50 pF R _L =500Ω	1.5	12.0	ns	1, 7, 8
		C _L =300 pF ^[17] R _L =500Ω	1.5	23.0		
t _{PHZ} t _{PLZ}	Output Disable Time $\overline{\text{OE}}$ to Q	C _L =5 pF ^[17] R _L =500Ω	1.5	7.0	ns	1, 7, 8
		C _L =50 pF R _L =500Ω	1.5	8.0		
t _{SU}	Set-Up Time HIGH or LOW, D to CLK	C _L =50 pF R _L =500Ω	3.0	—	ns	4
t _H	Hold Time HIGH or LOW, D to CLK		1.5	—	ns	4
t _{SU}	Set-Up Time HIGH or LOW, $\overline{\text{CLKEN}}$ to CLK		3.0	—	ns	9
t _H	Hold Time HIGH or LOW $\overline{\text{CLKEN}}$ to CLK		0.0	—	ns	9
t _W	CLK Pulse Width HIGH or LOW		6.0	—	ns	5
t _W	$\overline{\text{CLR}}$ Pulse Width LOW		6.0	—	ns	5
t _{REM}	Recovery Time $\overline{\text{CLR}}$ to CLK		6.0	—	ns	6
t _{SK(O)}	Output Skew ^[18]		—	0.5	ns	—

Switching Characteristics Over the Operating Range^[15]

Parameter	Description	Condition ^[16]	CY74FCT16823CT CY74FCT162823CT		CY74FCT16823ET CY74FCT162823ET		Unit	Fig.No. ^[16]
			Min.	Max.	Min.	Max.		
t _{PLH} t _{PHL}	Propagation Delay CLK to Q	C _L =50 pF R _L =500Ω	1.5	6.0	1.5	4.4	ns	1, 5
		C _L =300 pF ^[17] R _L =500Ω	1.5	12.5	1.5	8.0		
t _{PHL}	Propagation Delay $\overline{\text{CLR}}$ to Q	C _L =50 pF R _L =500Ω	1.5	6.1	1.5	4.4	ns	1, 5
t _{PZH} t _{PZL}	Output Enable Time $\overline{\text{OE}}$ to Q	C _L =50 pF R _L =500Ω	1.5	5.5	1.5	4.4	ns	1, 7, 8
		C _L =300 pF ^[17] R _L =500Ω	1.5	12.5	1.5	9.0		
t _{PHZ} t _{PLZ}	Output Disable Time $\overline{\text{OE}}$ to Q	C _L =5 pF ^[17] R _L =500Ω	1.5	5.2	1.5	3.6	ns	1, 7, 8
		C _L =50 pF R _L =500Ω	1.5	6.5	1.5	3.6		

Switching Characteristics Over the Operating Range^[15] (continued)

Parameter	Description	Condition ^[16]	CY74FCT16823CT CY74FCT162823CT		CY74FCT16823ET CY74FCT162823ET		Unit	Fig.No. ^[16]
			Min.	Max.	Min.	Max.		
t _{SU}	Set-Up Time HIGH or LOW, D to CLK	C _L =50 pF R _L =500Ω	2.0	—	1.5	—	ns	4
t _H	Hold Time HIGH or LOW, D to CLK		1.5	—	0.0	—	ns	4
t _{SU}	Set-Up Time HIGH or LOW, $\overline{\text{CLKEN}}$ to CLK		3.0	—	2.5	—	ns	9
t _H	Hold Time HIGH or LOW CLKEN to CLK		0.0	—	0.0	—	ns	9
t _W	CLK Pulse Width HIGH or LOW		3.3	—	3.3	—	ns	5
t _W	$\overline{\text{CLR}}$ Pulse Width LOW		3.3	—	3.0	—	ns	5
t _{REM}	Recovery Time CLR to CLK		6.0	—	3.0	—	ns	6
t _{SK(O)}	Output Skew ^[18]		—	0.5	—	0.5	ns	—

Notes:

15. Minimum limits are specified but not tested on Propagation Delays.
16. See "Parameter Measurement Information" in the General Information section.
17. These limits are specified but not tested.
18. Skew between any two outputs of the same package switching in the same direction. This parameter is ensured by design.

Ordering Information CY74FCT16823

Speed (ns)	Ordering Code	Package Name	Package Type	Operating Range
4.4	CY74FCT16823ETPACT	Z56	56-Lead (240-Mil) TSSOP	Industrial
	CY74FCT16823ETPVC/PVCT	O56	56-Lead (300-Mil) SSOP	
6.0	CY74FCT16823CTPACT	Z56	56-Lead (240-Mil) TSSOP	Industrial
	CY74FCT16823CTPVC/PVCT	O56	56-Lead (300-Mil) SSOP	
10.0	CY74FCT16823ATPACT	Z56	56-Lead (240-Mil) TSSOP	Industrial

Ordering Information CY74FCT162823

Speed (ns)	Ordering Code	Package Name	Package Type	Operating Range
4.4	74FCT162823ETPACT	Z56	56-Lead (240-Mil) TSSOP	Industrial
	CY74FCT162823ETPVC	O56	56-Lead (300-Mil) SSOP	
	74FCT162823ETPVCT	O56	56-Lead (300-Mil) SSOP	
6.0	74FCT162823CTPACT	Z56	56-Lead (240-Mil) TSSOP	Industrial
	CY74FCT162823CTPVC	O56	56-Lead (300-Mil) SSOP	
	74FCT162823CTPVCT	O56	56-Lead (300-Mil) SSOP	
10.0	74FCT162823ATPACT	Z56	56-Lead (240-Mil) TSSOP	Industrial

Package Diagrams

56-Lead Shrunken Small Outline Package O56

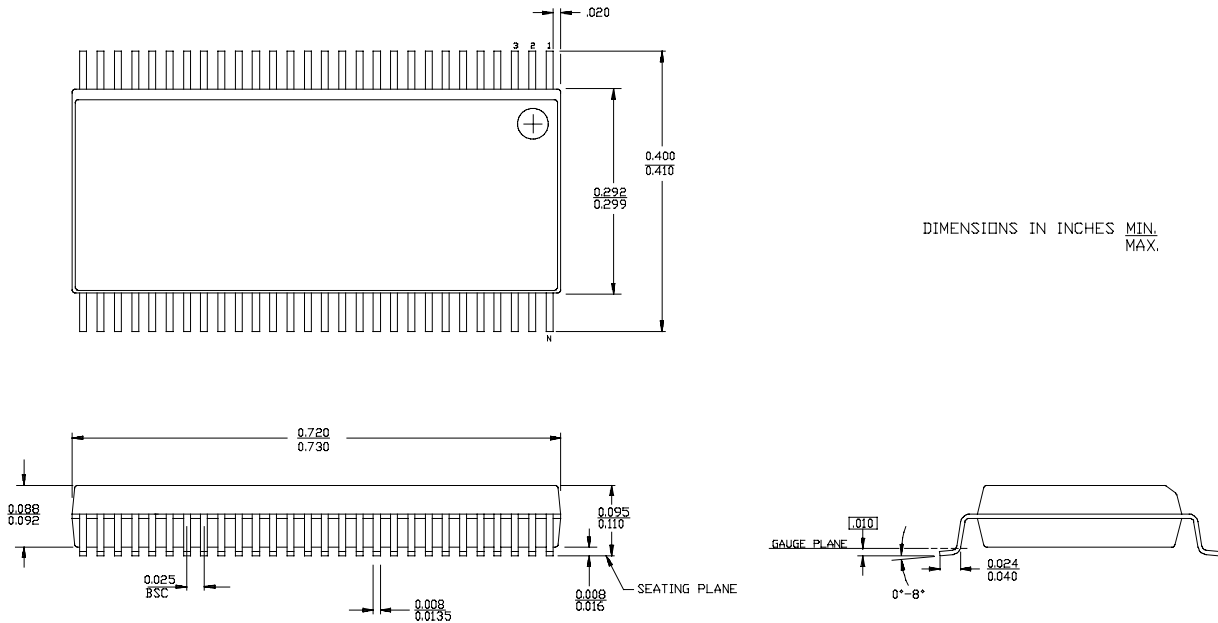

56-Lead Thin Shrunken Small Outline Package Z56

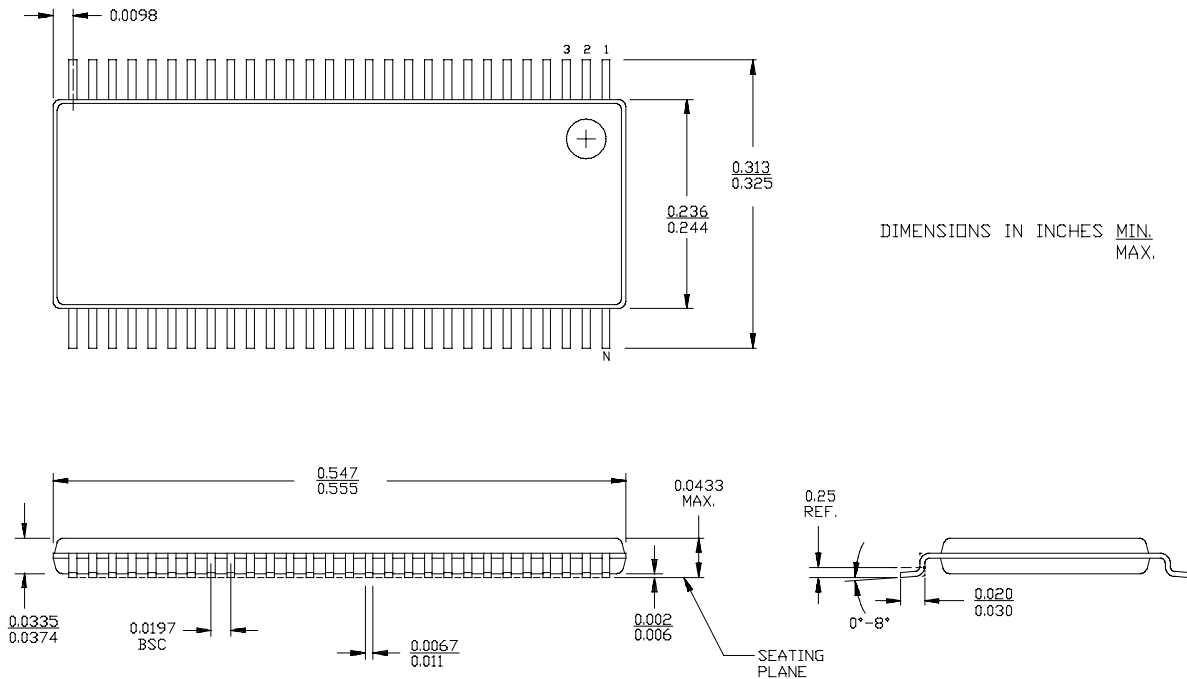

IMPORTANT NOTICE

Texas Instruments and its subsidiaries (TI) reserve the right to make changes to their products or to discontinue any product or service without notice, and advise customers to obtain the latest version of relevant information to verify, before placing orders, that information being relied on is current and complete. All products are sold subject to the terms and conditions of sale supplied at the time of order acknowledgement, including those pertaining to warranty, patent infringement, and limitation of liability.

TI warrants performance of its semiconductor products to the specifications applicable at the time of sale in accordance with TI's standard warranty. Testing and other quality control techniques are utilized to the extent TI deems necessary to support this warranty. Specific testing of all parameters of each device is not necessarily performed, except those mandated by government requirements.

CERTAIN APPLICATIONS USING SEMICONDUCTOR PRODUCTS MAY INVOLVE POTENTIAL RISKS OF DEATH, PERSONAL INJURY, OR SEVERE PROPERTY OR ENVIRONMENTAL DAMAGE ("CRITICAL APPLICATIONS"). TI SEMICONDUCTOR PRODUCTS ARE NOT DESIGNED, AUTHORIZED, OR WARRANTED TO BE SUITABLE FOR USE IN LIFE-SUPPORT DEVICES OR SYSTEMS OR OTHER CRITICAL APPLICATIONS. INCLUSION OF TI PRODUCTS IN SUCH APPLICATIONS IS UNDERSTOOD TO BE FULLY AT THE CUSTOMER'S RISK.

In order to minimize risks associated with the customer's applications, adequate design and operating safeguards must be provided by the customer to minimize inherent or procedural hazards.

TI assumes no liability for applications assistance or customer product design. TI does not warrant or represent that any license, either express or implied, is granted under any patent right, copyright, mask work right, or other intellectual property right of TI covering or relating to any combination, machine, or process in which such semiconductor products or services might be or are used. TI's publication of information regarding any third party's products or services does not constitute TI's approval, warranty or endorsement thereof.