

SN54HC109, SN74HC109 DUAL J-K POSITIVE-EDGE-TRIGGERED FLIP-FLOPS WITH CLEAR AND PRESET

D2684, DECEMBER 1982—REVISED JUNE 1989

- Package Options Include Plastic "Small Outline" Packages, Ceramic Chip Carriers, and Standard Plastic and Ceramic 300-mil DIPs
- Dependable Texas Instruments Quality and Reliability

description

These devices contain two independent J-K negative-edge-triggered flip-flops. A low level at the Preset or clear inputs sets or resets the outputs regardless of the levels of the other inputs. When Preset and Clear are inactive (high), data at the J and K inputs meeting the setup time requirements are transferred to the outputs on the positive-going edge of the clock pulse. Clock triggering occurs at a voltage level and is not directly related to the rise time of the clock pulse. Following the hold time interval, data at the J and K inputs may be changed without affecting the levels at the outputs. These versatile flip-flops can perform as toggle flip-flops by grounding K and tying J high. They also can perform as D-type flip-flops if J and K are tied together.

The SN54HC109 is characterized for operation over the full military temperature range of -55°C to 125°C . The SN74HC109 is characterized for operation from -40°C to 85°C .

FUNCTION TABLE

INPUTS					OUTPUTS	
PRE	CLR	CLK	J	K	Q	\bar{Q}
L	H	X	X	X	H	L
H	L	X	X	X	L	H
L	L	X	X	X	H [‡]	H [‡]
H	H	↑	L	L	L	H
H	H	↑	H	L	TOGGLE	
H	H	↑	L	H	Q ₀	\bar{Q}_0
H	H	↑	H	H	H	L
H	H	L	X	X	Q ₀	\bar{Q}_0

[‡]This configuration is nonstable; that is, it will not persist when Preset or Clear return to their inactive (high) level.

SN54HC109 . . . J PACKAGE
SN74HC109 . . . D OR N PACKAGE
(TOP VIEW)

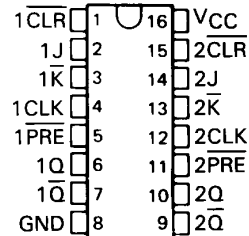

SN54HC109 . . . FK PACKAGE
(TOP VIEW)

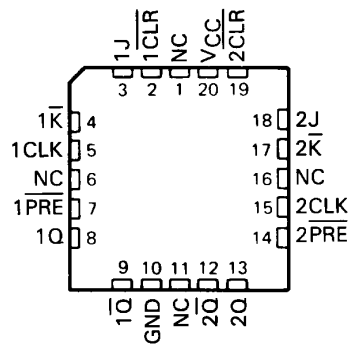

NC—No internal connection

logic symbol[†]

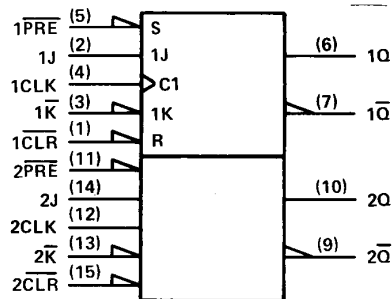

[†]This symbol is in accordance with ANSI/IEEE Std 91-1984 and IEC Publication 617-12.

Pin numbers shown are for D, J, and N packages.

2

HCMOS Devices

PRODUCTION DATA documents contain information current as of publication date. Products conform to specifications per the terms of Texas Instruments standard warranty. Production processing does not necessarily include testing of all parameters.

TEXAS
INSTRUMENTS

POST OFFICE BOX 655012 • DALLAS, TEXAS 75265

Copyright © 1989, Texas Instruments Incorporated

2-137

SN54HC109, SN74HC109
DUAL J-K POSITIVE-EDGE-TRIGGERED
FLIP-FLOPS WITH CLEAR AND PRESET

logic diagram, each flip-flop (positive logic)

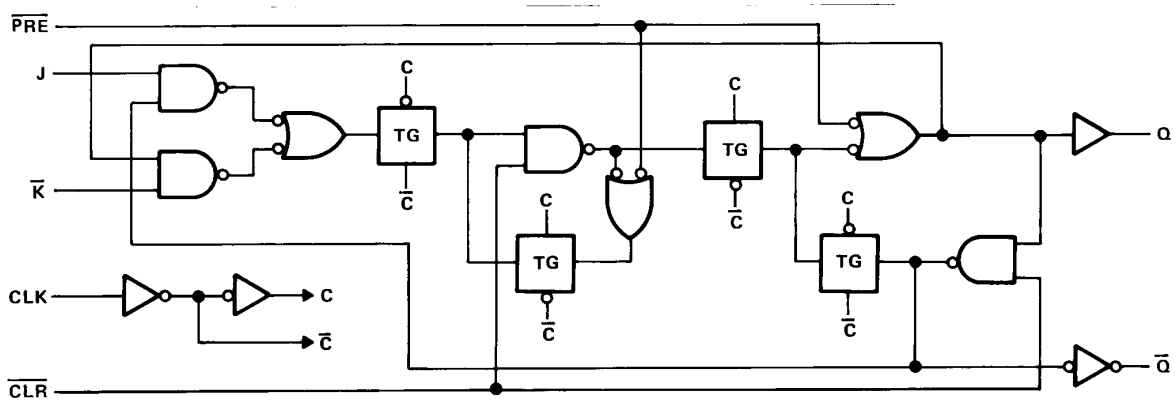

absolute maximum ratings over operating free-air temperature range†

Supply voltage, V_{CC}	-0.5 V to 7 V
Input clamp current, I_{IK} ($V_I < 0$ or $V_I > V_{CC}$)	± 20 mA
Output clamp current, I_{OK} ($V_O < 0$ or $V_O > V_{CC}$)	± 20 mA
Continuous output current, I_O ($V_O = 0$ to V_{CC})	± 25 mA
Continuous current through V_{CC} or GND pins	± 50 mA
Lead temperature 1,6 mm (1/16 in) from case for 60 s: FK or J package	300 °C
Lead temperature 1,6 mm (1/16 in) from case for 10 s: D or N package	260 °C
Storage temperature range	-65 °C to 150 °C

† Stresses beyond those listed under "absolute maximum ratings" may cause permanent damage to the device. These are stress ratings only, and functional operation of the device at these or any other conditions beyond those indicated under "recommended operating conditions" is not implied. Exposure to absolute-maximum-rated conditions for extended periods may affect device reliability.

recommended operating conditions

		SN54HC109			SN74HC109			UNIT
		MIN	NOM	MAX	MIN	NOM	MAX	
V_{CC}	Supply voltage	2	5	6	2	5	6	V
V_{IH}	High-level input voltage	$V_{CC} = 2$ V		1.5	$V_{CC} = 2$ V		1.5	V
		$V_{CC} = 4.5$ V		3.15	$V_{CC} = 4.5$ V		3.15	
		$V_{CC} = 6$ V		4.2	$V_{CC} = 6$ V		4.2	
V_{IL}	Low-level input voltage	$V_{CC} = 2$ V		0	0.3	$V_{CC} = 2$ V		V
		$V_{CC} = 4.5$ V		0	0.9	$V_{CC} = 4.5$ V		
		$V_{CC} = 6$ V		0	1.2	$V_{CC} = 6$ V		
V_I	Input voltage	0			V_{CC}			V
V_O	Output voltage	0			V_{CC}			V
t_t	Input transition (rise and fall) times	$V_{CC} = 2$ V		0	1000	$V_{CC} = 2$ V		ns
		$V_{CC} = 4.5$ V		0	500	$V_{CC} = 4.5$ V		
		$V_{CC} = 6$ V		0	400	$V_{CC} = 6$ V		
T_A	Operating free-air temperature	-55		125	-40		85	°C

SN54HC109, SN74HC109
DUAL J-K POSITIVE-EDGE-TRIGGERED
FLIP-FLOPS WITH CLEAR AND PRESET

electrical characteristics over recommended operating free-air temperature range (unless otherwise noted)

PARAMETER	TEST CONDITIONS	V _{CC}	T _A = 25°C			SN54HC109		SN74HC109		UNIT
			MIN	TYP	MAX	MIN	MAX	MIN	MAX	
V _{OH}	V _I = V _{IH} or V _{IL} , I _{OH} = -20 μA	2 V	1.9	1.998		1.9		1.9	V	
		4.5 V	4.4	4.499		4.4		4.4		
		6 V	5.9	5.999		5.9		5.9		
	V _I = V _{IH} or V _{IL} , I _{OH} = -4 mA	4.5 V	3.98	4.30		3.7		3.84		
	V _I = V _{IH} or V _{IL} , I _{OH} = -5.2 mA	6 V	5.48	5.80		5.2		5.34		
V _{OL}	V _I = V _{IH} or V _{IL} , I _{OL} = 20 μA	2 V		0.002	0.1		0.1		0.1	V
		4.5 V		0.001	0.1		0.1		0.1	
		6 V		0.001	0.1		0.1		0.1	
	V _I = V _{IH} or V _{IL} , I _{OL} = 4 mA	4.5 V		0.17	0.26		0.4		0.33	
	V _I = V _{IH} or V _{IL} , I _{OL} = 5.2 mA	6 V		0.15	0.26		0.4		0.33	
I _I	V _I = V _{CC} or 0	6 V		±0.1	±100		±1000		±1000	nA
I _{CC}	V _I = V _{CC} or 0, I _O = 0	6 V			4		80		40	μA
C _I		2 to 6 V		3	10		10		10	pF

timing requirements over recommended operating free-air temperature range (unless otherwise noted)

		V _{CC}	T _A = 25°C			SN54HC109		SN74HC109		UNIT
			MIN		MAX	MIN	MAX	MIN	MAX	
f _{clock}	Clock frequency	2 V	0		6	0	4.2	0	5	MHz
		4.5 V	0		31	0	21	0	25	
		6 V	0		36	0	25	0	29	
t _w	Pulse duration	PRE or CLR low	2 V	100			150		125	ns
			4.5 V	20			30		25	
			6 V	17			25		21	
	CLK high or low	2 V	80			120		100		
		4.5 V	16			24		20		
		6 V	14			20		17		
t _{su}	Setup time before CLK↑	Data (J, K)	2 V	100			150		125	ns
			4.5 V	20			30		25	
			6 V	17			25		21	
	PRE or CLR inactive	2 V	25			40		30		
		4.5 V	5			8		6		
		6 V	4			7		5		
t _h	Hold time, data after CLK↑	2 V	0			0		0	ns	
		4.5 V	0			0		0		
		6 V	0			0		0		

2

HCMOS Devices

SN54HC109, SN74HC109
DUAL J-K POSITIVE-EDGE-TRIGGERED
FLIP-FLOPS WITH CLEAR AND PRESET

switching characteristics over recommended operating free-air temperature range (unless otherwise noted), $C_L = 50$ pF (see Note 1)

PARAMETER	FROM (INPUT)	TO (OUTPUT)	V _{CC}	T _A = 25°C			SN54HC109		SN74HC109		UNIT
				MIN	TYP	MAX	MIN	MAX	MIN	MAX	
f _{max}			2 V	6	10		4.2		5	MHz	
			4.5 V	31	50		21		25		
			6 V	36	60		25		29		
t _{pd}	PRE or CLR	Q or Q̄	2 V		60	230		345		290	ns
			4.5 V		15	46		69		58	
			6 V		12	39		59		49	
t _{pd}	CLK	Q or Q̄	2 V		50	175		250		220	ns
			4.5 V		15	35		50		44	
			6 V		12	30		42		37	
t _t		Q or Q̄	2 V		28	75		110		95	ns
			4.5 V		8	15		22		19	
			6 V		6	13		19		16	

C _{pd}	Power dissipation capacitance per flip-flop	No load, T _A = 25°C	35 pF typ
-----------------	---	--------------------------------	-----------

NOTE 1: Load circuit and voltage waveforms are shown in Section 1.

IMPORTANT NOTICE

Texas Instruments and its subsidiaries (TI) reserve the right to make changes to their products or to discontinue any product or service without notice, and advise customers to obtain the latest version of relevant information to verify, before placing orders, that information being relied on is current and complete. All products are sold subject to the terms and conditions of sale supplied at the time of order acknowledgement, including those pertaining to warranty, patent infringement, and limitation of liability.

TI warrants performance of its semiconductor products to the specifications applicable at the time of sale in accordance with TI's standard warranty. Testing and other quality control techniques are utilized to the extent TI deems necessary to support this warranty. Specific testing of all parameters of each device is not necessarily performed, except those mandated by government requirements.

CERTAIN APPLICATIONS USING SEMICONDUCTOR PRODUCTS MAY INVOLVE POTENTIAL RISKS OF DEATH, PERSONAL INJURY, OR SEVERE PROPERTY OR ENVIRONMENTAL DAMAGE ("CRITICAL APPLICATIONS"). TI SEMICONDUCTOR PRODUCTS ARE NOT DESIGNED, AUTHORIZED, OR WARRANTED TO BE SUITABLE FOR USE IN LIFE-SUPPORT DEVICES OR SYSTEMS OR OTHER CRITICAL APPLICATIONS. INCLUSION OF TI PRODUCTS IN SUCH APPLICATIONS IS UNDERSTOOD TO BE FULLY AT THE CUSTOMER'S RISK.

In order to minimize risks associated with the customer's applications, adequate design and operating safeguards must be provided by the customer to minimize inherent or procedural hazards.

TI assumes no liability for applications assistance or customer product design. TI does not warrant or represent that any license, either express or implied, is granted under any patent right, copyright, mask work right, or other intellectual property right of TI covering or relating to any combination, machine, or process in which such semiconductor products or services might be or are used. TI's publication of information regarding any third party's products or services does not constitute TI's approval, warranty or endorsement thereof.