

# SMJ320C50/SMQ320C50 DIGITAL SIGNAL PROCESSOR

SGUS020 – JUNE 1996

- **Military Operating Temperature Range:**  
– 55°C to 125°C
- **Processed to MIL-PRF-38535**
- **Fast Instruction Cycle Time (30 ns and 40 ns)**
- **Source-Code Compatible With All 'C1x and 'C2x Devices**
- **RAM-Based Operation**
  - 9K × 16-Bit Single-Cycle On-Chip Program/Data RAM
  - 1056 × 16-Bit Dual-Access On-Chip Data RAM
- **2K × 16-Bit On-Chip Boot ROM**
- **224K × 16-Bit Maximum Addressable External Memory Space (64K Program, 64K Data, 64K I/O, and 32K Global)**
- **32-Bit Arithmetic Logic Unit (ALU)**
  - 32-bit Accumulator (ACC)
  - 32-Bit Accumulator Buffer (ACCB)
- **16-Bit Parallel Logic Unit (PLU)**
- **16 × 16-Bit Multiplier, 32-Bit Product**
- **11 Context-Switch Registers**
- **Two Buffers for Circular Addressing**
- **Full-Duplex Synchronous Serial Port**
- **Time-Division Multiplexed Serial Port (TDM)**
- **Timer With Control and Counter Registers**
- **16 Software Programmable Wait-State Generators**
- **Divide-by-One Clock Option**
- **IEEE 1149.1† Boundary Scan Logic**
- **Operations Are Fully Static**
- **Enhanced Performance Implanted CMOS (EPIC™) 0.72-μm Technology Fabricated by Texas Instruments**
- **Packaging**
  - 141-Pin Ceramic Grid Array (GFA Suffix)
  - 132-Lead Ceramic Quad Flat Package (HFG Suffix)
  - 132-Lead Plastic Quad Flat Package (PQ Suffix)

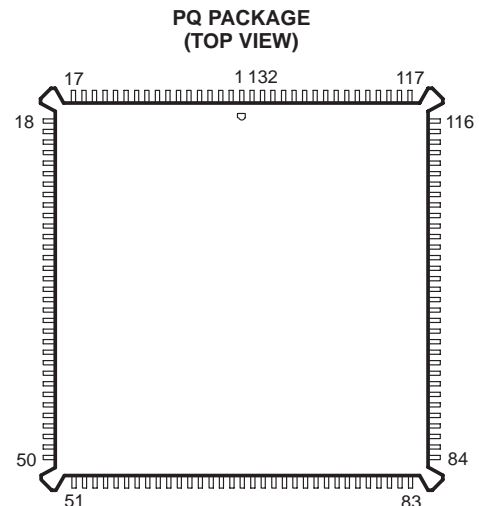
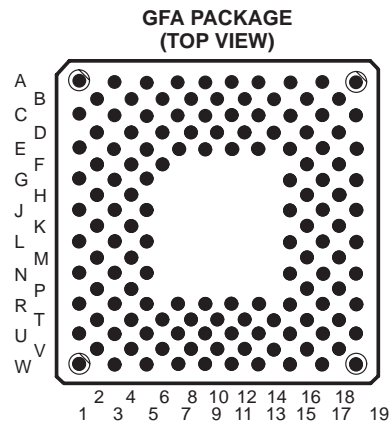
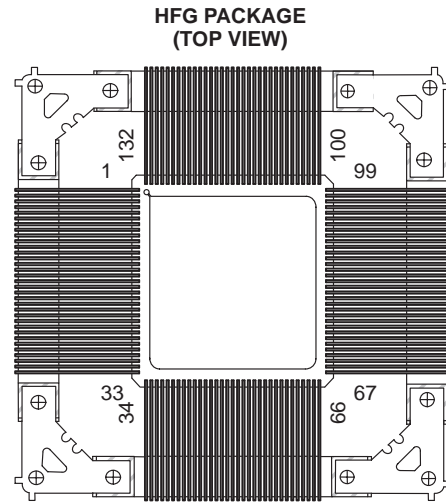

Please be aware that an important notice concerning availability, standard warranty, and use in critical applications of Texas Instruments semiconductor products and disclaimers thereto appears at the end of this data sheet.

† IEEE Standard 1149.1-1990 Standard-Test-Access Port and Boundary Scan Architecture  
EPIC and TI are trademarks of Texas Instruments Incorporated.

PRODUCTION DATA information is current as of publication date. Products conform to specifications per the terms of Texas Instruments standard warranty. Production processing does not necessarily include testing of all parameters.

**TEXAS  
INSTRUMENTS**

POST OFFICE BOX 1443 • HOUSTON, TEXAS 77251-1443

Copyright © 1996, Texas Instruments Incorporated

# SMJ320C50/SMQ320C50 DIGITAL SIGNAL PROCESSOR

SGUS020 – JUNE 1996

## description

The SMJ320C50 digital signal processor (DSP) is a high-performance, 16-bit, fixed-point processor manufactured in 0.72- $\mu\text{m}$  double-level metal CMOS technology. The SMJ320C50 is the first DSP from TI designed as a fully static device. Full-static CMOS design contributes to low power consumption while maintaining high performance, making it ideal for applications such as battery-operated communications systems, satellite systems, and advanced control algorithms.

A number of enhancements to the basic SMJ320C2x architecture give the 'C50 a minimum 2 $\times$  performance over the previous generation. A four-deep instruction pipeline, incorporating delayed branching, delayed call to subroutine, and delayed return from subroutine, allows the 'C50 to perform instructions in fewer cycles. The addition of a parallel logic unit (PLU) gives the 'C50 a method for manipulating bits in data memory without using the accumulator and ALU. The 'C50 has additional shifting and scaling capability for proper alignment of multiplicands or storage of values to data memory.

The 'C50 achieves its low-power consumption through the IDLE2 instruction. IDLE2 removes the functional clock from the internal hardware of the 'C50, which puts it into a total-sleep mode that uses only 7  $\mu\text{A}$ . A low-logic level on an external interrupt with a duration of at least five clock cycles ends the IDLE2 mode.

The 'C50 is available with two clock speeds. The clock frequencies are 50 MHz, providing a 40-ns cycle time, and 66 MHz, providing a 30-ns cycle time. The available options are listed in the following table.

### AVAILABLE OPTIONS

PART NUMBER	SPEED	SUPPLY VOLTAGE TOLERANCE	PACKAGE
SMJ320C50GFAM66	30-ns cycle time	$\pm 5\%$	Pin grid array
SMJ320C50HFGM66	30-ns cycle time	$\pm 5\%$	Quad flat package
SMJ320C50GFAM50	40 ns cycle time	$\pm 5\%$	Pin grid array
SMJ320C50HFGM50	40 ns cycle time	$\pm 5\%$	Quad flat package
SMQ320C50PQM66†	30 ns cycle time	$\pm 5\%$	Plastic Quad flat package

† When ordering use DESC P/N 5962-9455804N2D



functional block diagram

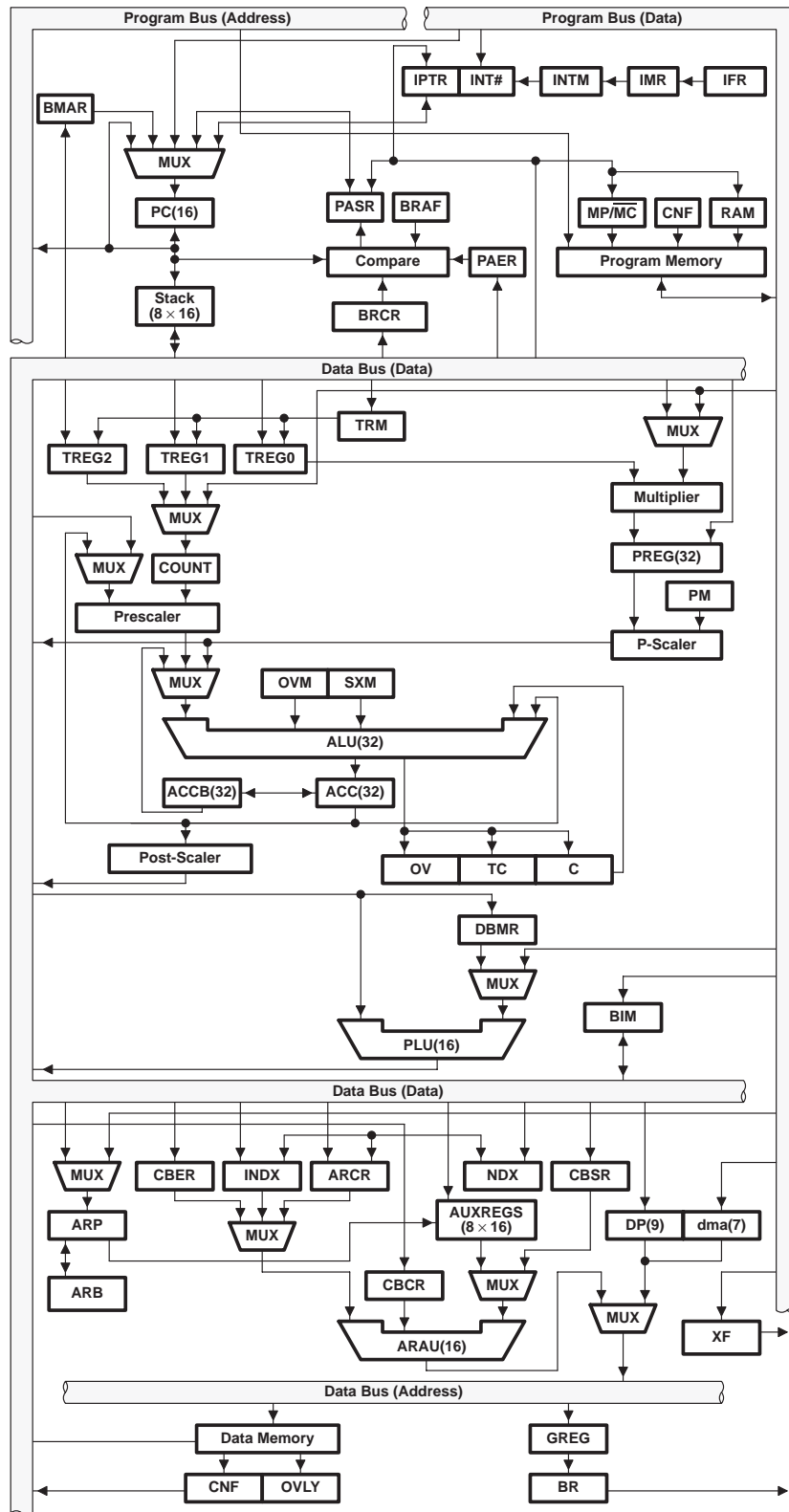

# SMJ320C50/SMQ320C50 DIGITAL SIGNAL PROCESSOR

SGUS020 – JUNE 1996

## pin assignments

PQ PKG	HFG PKG	GFA PKG	NAME	PQ PKG	HFG PKG	GFA PKG	NAME
18	1		NC†	57	40	W3	A2
19	2		NC†	58	41	U7	A3
20	3	D8	VSS3	59	42	V6	A4
21	4	D10	VSS4	60	43	W5	A5
22	5		NC†	61	44	U9	A6
23	6	E3	D7	62	45	V8	A7
24	7	D2	D6	63	46	W7	A8
25	8	C1	D5	64	47	W9	A9
26	9	G3	D4	65	48	E9	VDD7
27	10	F2	D3	66	49	E11	VDD8
28	11	E1	D2	67	50	V10	TDI
29	12	J3	D1	68	51	K4	VSS9
30	13	H2	D0(LSB)	69	52	M4	VSS10
31	14	G1	TMS	70	53		NC†
32	15	C3	VDD3	71	54	W11	CLKMD1
33	16	D4	VDD4	72	55	W13	A10
34	17	J1	TCK	73	56	V12	A11
35	18	D12	VSS5	74	57	U11	A12
36	19	F4	VSS6	75	58	W15	A13
37	20		NC†	76	59	V14	A14
38	21	L1	$\overline{\text{INT1}}$	77	60	U13	A15(MSB)
39	22	N1	$\overline{\text{INT2}}$	78	61		NC†
40	23	M2	$\overline{\text{INT3}}$	79	62		NC†
41	24	L3	$\overline{\text{INT4}}$	80	63	E13	VDD9
42	25	R1	$\overline{\text{NM}}$	81	64	G5	VDD10
43	26	P2	DR	82	65	V16	$\overline{\text{RD}}$
44	27	N3	TDR	83	66	U15	$\overline{\text{WE}}$
45	28	T2	FSR	84	67		NC†
46	29	R3	CLKR	85	68		NC†
47	30	E5	VDD5	86	69	P4	VSS11
48	31	E7	VDD6	87	70	T4	VSS12
49	32		NC†	88	71		NC†
50	33		NC†	89	72	R17	$\overline{\text{DS}}$
51	34		NC†	90	73	T18	$\overline{\text{IS}}$
52	35		NC†	91	74	U19	$\overline{\text{PS}}$
53	36	H4	VSS7	92	75	N17	$\overline{\text{R/W}}$
54	37	K2	VSS8	93	76	P18	$\overline{\text{STRB}}$
55	38	U5	A0	94	77	R19	$\overline{\text{BR}}$
56	39	V4	A1	95	78	L17	CLKIN2

† NC = No internal connection

GFA Package additional connections:

V<sub>DD</sub>: R11, E15, G15, J15, L15, N15, R13, R15, T16, U17, V18, W17, W19

V<sub>SS</sub>: T14, U1, U3, V2, W1, C17, C19, D14, D16, D18, F16, H16, K16, M16, P16



POST OFFICE BOX 1443 • HOUSTON, TEXAS 77251-1443

pin assignments (continued)

PQ PKG	HFG PKG	GFA PKG	NAME	PQ PKG	HFG PKG	GFA PKG	NAME
96	79	M18	X2/CLKIN	123	106	B16	TCLKX
97	80	N19	X1	124	107	A17	CLKX
98	81	J5	VDD11	125	108	C13	TFSR/TADD
99	82	L5	VDD12	126	109	B14	TCLKR
100	83	L19	TDO	127	110	A15	$\overline{RS}$
101	84	T6	VSS13	128	111	C11	READY
102	85	T8	VSS14	129	112	B12	$\overline{HOLD}$
103	86	K18	CLKMD2	130	113	A13	$\overline{BIO}$
104	87	J19	FSX	131	114	R7	VDD15
105	88	G19	TFSX/TFRM	132	115	R9	VDD16
106	89	H18	DX	1	116	A11	$\overline{IAQ}$
107	90	J17	TDX	2	117	A9	$\overline{TRST}$
108	91	E19	$\overline{HOLDA}$	3	118	B10	VSS1
109	92	F18	XF	4	119	D6	VSS2
110	93	G17	CLKOUT1	5	120	A7	MP/MC
111	94		NCT	6	121	B8	D15(MSB)
112	95	E17	$\overline{IACK}$	7	122	C9	D14
113	96	N5	VDD13	8	123	A5	D13
114	97	R5	VDD14	9	124	B6	D12
115	98		NCT	10	125	C7	D11
116	99		NCT	11	126	A3	D10
117	100		NCT	12	127	B4	D9
118	101	B18	EMU0	13	128	C5	D8
119	102	A19	EMU1/ $\overline{OFF}$	14	129	A1	VDD1
120	103	T10	VSS15	15	130	B2	VDD2
121	104	T12	VSS16	16	131		NCT
122	105	C15	TOUT	17	132		NCT

† NC = No internal connection

GFA Package additional connections:

VDD: R11, E15, G15, J15, L15, N15, R13, R15, T16, U17, V18, W17, W19

VSS: T14, U1, U3, V2, W1, C17, C19, D14, D16, D18, F16, H16, K16, M16, P16



# SMJ320C50/SMQ320C50 DIGITAL SIGNAL PROCESSOR

SGUS020 – JUNE 1996

## Terminal Functions

PIN		DESCRIPTION
NAME	TYPE†	
<b>ADDRESS AND DATA BUSES</b>		
A15 (MSB) A14 A13 A12 A11 A10 A9 A8 A7 A6 A5 A4 A3 A2 A1 A0 (LSB)	I/O/Z	Parallel address bus. Multiplexed to address external data, program memory, or I/O. A0–A15 are in the high-impedance state in hold mode and when $\overline{\text{OFF}}$ is active (low). These signals are used as inputs for external DMA access of the on-chip single-access RAM. They become inputs while $\overline{\text{HOLDA}}$ is active (low) if $\overline{\text{BR}}$ is driven low externally.
D15 (MSB) D14 D13 D12 D11 D10 D9 D8 D7 D6 D5 D4 D3 D2 D1 D0 (LSB)	I/O/Z	Parallel data bus. Multiplexed to transfer data between the core CPU and external data, program memory, or I/O devices. D0–D15 are in the high-impedance state when not outputting data, when $\overline{\text{RS}}$ or $\overline{\text{HOLD}}$ is asserted, or when $\overline{\text{OFF}}$ is active (low). These signals also are used in external DMA access of the on-chip single-access RAM.
<b>MEMORY CONTROL SIGNALS</b>		
$\overline{\text{DS}}$ $\overline{\text{PS}}$ $\overline{\text{IS}}$	O/Z	Data, program, and I/O space select signals. Always high unless asserted for communicating to a particular external space. $\overline{\text{DS}}$ , $\overline{\text{PS}}$ , and $\overline{\text{IS}}$ are in the high-impedance state in hold mode or when $\overline{\text{OFF}}$ is active (low).
READY	I	Data ready input. Indicates that an external device is prepared for the bus transaction to be completed. If the device is not ready (READY is low), the processor waits one cycle and checks READY again. READY also indicates a bus grant to an external device after a $\overline{\text{BR}}$ (bus request) signal.
R/ $\overline{\text{W}}$	I/O/Z	Read/write. R/ $\overline{\text{W}}$ indicates transfer direction during communication to an external device and is normally in read mode (high) unless asserted for performing a write operation. R/ $\overline{\text{W}}$ is in the high-impedance state in hold mode or when $\overline{\text{OFF}}$ is active (low). Used in external DMA access of the 9K RAM cell, this signal indicates the direction of the data bus for DMA reads (high) and writes (low) when $\overline{\text{HOLDA}}$ and $\overline{\text{IAQ}}$ are active (low).
$\overline{\text{STRB}}$	I/O/Z	Strobe. Always high unless asserted to indicate an external bus cycle, $\overline{\text{STRB}}$ is in the high-impedance state in the hold mode or when $\overline{\text{OFF}}$ is active (low). Used in external DMA access of the on-chip single-access RAM and while $\overline{\text{HOLDA}}$ and $\overline{\text{IAQ}}$ are active (low), $\overline{\text{STRB}}$ is used to select the memory access.
$\overline{\text{RD}}$	O/Z	Read select. $\overline{\text{RD}}$ indicates an active external read cycle and can connect directly to the output enable ( $\overline{\text{OE}}$ ) of external devices. This signal is active on all external program, data, and I/O reads. $\overline{\text{RD}}$ is in the high-impedance state in hold mode or when $\overline{\text{OFF}}$ is active (low).

† I = input, O = output, Z = high-impedance

NOTE: All input pins that are unused should be connected to  $V_{\text{DD}}$  or an external pullup resistor. The  $\overline{\text{BR}}$  pin has an internal pullup for performing DMA to the on-chip RAM. For emulation,  $\overline{\text{TRST}}$  has an internal pulldown, and TMS, TCK, and TDI have internal pullups. EMU0 and EMU1 require external pullups to support emulation.



Terminal Functions (continued)

PIN		DESCRIPTION
NAME	TYPE†	
<b>MEMORY CONTROL SIGNALS (CONTINUED)</b>		
$\overline{WE}$	O/Z	Write enable. The falling edge indicates that the device is driving the external data bus (D15–D0). Data can be latched by an external device on the rising edge of $\overline{WE}$ . This signal is active on all external program, data, and I/O writes. $\overline{WE}$ is in the high-impedance state in hold mode or when $\overline{OFF}$ is active (low).
<b>MULTIPROCESSING SIGNALS</b>		
$\overline{HOLD}$	I	Hold. $\overline{HOLD}$ is asserted to request control of the address, data, and control lines. When acknowledged by the 'C50, these lines go to the high-impedance state.
$\overline{HOLDA}$	O/Z	Hold acknowledge. $\overline{HOLDA}$ indicates to the external circuitry that the processor is in a hold state and that the address, data, and memory control lines are in the high-impedance state so that they are available to the external circuitry for access to local memory. This signal also goes to the high-impedance state when $\overline{OFF}$ is active (low).
$\overline{BR}$	I/O/Z	Bus request. $\overline{BR}$ is asserted during access of external global data memory space. $\overline{READY}$ is asserted when the global data memory is available for the bus transaction. $\overline{BR}$ can be used to extend the data memory address space by up to 32K words. $\overline{BR}$ goes to the high-impedance state when $\overline{OFF}$ is active low. $\overline{BR}$ is used in external DMA access of the on-chip single-access RAM. While $\overline{HOLDA}$ is active (low), $\overline{BR}$ is externally driven (low) to request access to the on-chip single-access RAM.
$\overline{IAQ}$	O/Z	Instruction acquisition. Asserted (active) when there is an instruction address on the address bus; goes into the high-impedance state when $\overline{OFF}$ is active (low). $\overline{IAQ}$ is also used in external DMA access of the on-chip single-access RAM. While $\overline{HOLDA}$ is active (low), $\overline{IAQ}$ acknowledges the $\overline{BR}$ request for access of the on-chip single-access RAM and stops indicating instruction acquisition.
$\overline{BIO}$	I	Branch control. $\overline{BIO}$ samples as the $\overline{BIO}$ condition and, if it is low, causes the device to execute the conditional instruction. $\overline{BIO}$ must be active during the fetch of the conditional instruction.
XF	O/Z	External flag (latched software-programmable signal). Set high or low by a specific instruction or by loading status register 1 (ST1). Used for signaling other processors in multiprocessor configurations or as a general-purpose output. XF goes to the high-impedance state when $\overline{OFF}$ is active (low) and is set high at reset.
$\overline{IACK}$	O/Z	Interrupt acknowledge. Indicates receipt of an interrupt and that the program counter is fetching the interrupt vector location designated by A15–A0. $\overline{IACK}$ goes to the high-impedance state when $\overline{OFF}$ is active (low).
<b>INITIALIZATION, INTERRUPT, AND RESET OPERATIONS</b>		
$\overline{INT4}$ $\overline{INT3}$ $\overline{INT2}$ $\overline{INT1}$	I	External interrupts. $\overline{INT1}$ – $\overline{INT4}$ are prioritized and maskable by the interrupt mask register (IMR) and interrupt mode bit (INTM, bit 9 of status register 0). These signals can be polled and reset by using the interrupt flag register.
$\overline{NMI}$	I	Nonmaskable interrupt. $\overline{NMI}$ is the external interrupt that cannot be masked via INTM or IMR. When $\overline{NMI}$ is activated, the processor traps to the appropriate vector location.
$\overline{RS}$	I	Reset. $\overline{RS}$ causes the device to terminate execution and forces the program counter to zero. When $\overline{RS}$ is brought to a high level, execution begins at location zero of program memory.
MP/ $\overline{MC}$	I	Microprocessor/microcomputer select. If active (low) at reset (microcomputer mode), the signal causes the internal program ROM to be mapped into program memory space. In the microprocessor mode, all program memory is mapped externally. This signal is sampled only during reset, and the mode that is set at reset can be overridden via the software control bit MP/ $\overline{MC}$ in the PMST register.
<b>OSCILLATOR/TIMER SIGNALS</b>		
CLKOUT1	O/Z	Master clock (or CLKIN2 frequency). CLKOUT1 cycles at the machine-cycle rate of the CPU. The internal machine cycle is bounded by the rising edges of this signal. This signal goes to the high-impedance state when $\overline{OFF}$ is active (low).

† I = input, O = output, Z = high-impedance

# SMJ320C50/SMQ320C50 DIGITAL SIGNAL PROCESSOR

SGUS020 – JUNE 1996

## Terminal Functions (continued)

PIN		DESCRIPTION
NAME	TYPE†	
<b>OSCILLATOR/TIMER SIGNALS (CONTINUED)</b>		
CLKMD1 CLKMD2	I	CLKMD1 CLKMD2 Clock mode
		0 0 External clock with divide-by-two option. Input clock is provided to X2/CLKIN1. Internal oscillator and PLL are disabled.
		0 1 Reserved for test purposes
		1 0 External divide-by-one option. Input clock is provided to CLKIN2. Internal oscillator is disabled and internal PLL is enabled.
		1 1 Internal or external divide-by-two option. Input clock is provided to X2/CLKIN1. Internal oscillator is enabled and internal PLL is disabled.
X2/CLKIN	I	Input to the internal oscillator from the crystal. If the internal oscillator is not being used, a clock can be input to the device on X2/CLKIN. The internal machine cycle is half this clock rate.
X1	O	Output from the internal oscillator for the crystal. If the internal oscillator is not used, X1 must be left unconnected. This signal does not go to the high-impedance state when $\overline{OFF}$ is active (low).
CLKIN2	I	Divide-by-one input clock for driving the internal machine rate.
TOUT	O	Timer output. TOUT signals a pulse when the on-chip timer counts down past zero. The pulse is a CLKOUT1 cycle wide.
<b>SUPPLY PINS</b>		
VDD1 VDD2 VDD3 VDD4	I	Power supply for data bus
VDD5 VDD6	I	Power supply for address bus
VDD7 VDD8	I	Power supply for inputs and internal logic
VDD9 VDD10	I	Power supply for address bus
VDD11 VDD12	I	Power supply for memory control signals
VDD13 VDD14	I	Power supply for inputs and internal logic
VDD15 VDD16	I	Power supply for memory control signals
VSS1 VSS2	I	Ground for memory control signals
VSS3 VSS4 VSS5 VSS6	I	Ground for data bus
VSS7 VSS8 VSS9 VSS10	I	Ground for address bus
VSS11 VSS12	I	Ground for memory control signals
VSS13 VSS14 VSS15 VSS16	I	Ground for inputs and internal logic

† I = input, O = output, Z = high-impedance



POST OFFICE BOX 1443 • HOUSTON, TEXAS 77251-1443



Terminal Functions (continued)

PIN		DESCRIPTION
NAME	TYPET†	
<b>SERIAL PORT SIGNALS</b>		
CLKR TCLKR	I	Receive clock. External clock signal for clocking data from DR (data receive) or TDR (TDM data receive) into the RSR (serial port receive shift register). Must be present during serial port transfers. If the serial port is not being used, these signals can be sampled as an input via the IN0 bit of the serial port control (SPC) or TDR serial port control (TSPC) registers.
CLKX TCLKX	I/O/Z	Transmit clock. Clock signal for clocking data from the DR or TDR to the DX (data transmit) or TDX (TDM data transmit pins). CLKX can be an input if the MCM bit in the serial port control register is set to 0. It can also be driven by the device at 1/4 the CLKOUT1 frequency when the MCM bit is set to 1. If the serial port is not being used, this pin can be sampled as an input via the IN1 bit of the SPC or TSPC register. This signal goes into the high-impedance state when $\overline{\text{OFF}}$ is active (low).
DR TDR	I	Serial data receive. Serial data is received in the RSR (serial port receive shift register) via DR or TDR.
DX TDX	O/Z	Serial port transmit. Serial data transmitted from XSR (serial port transmit shift register) via DX or TDX. This signal is in the high-impedance state when not transmitting and when $\overline{\text{OFF}}$ is active (low).
FSR TFSR/TADD	I I/O/Z	Frame synchronization pulse for receive. The falling edge of FSR or TFSR initiates the data receive process, which begins the clocking of the RSR. TFSR becomes an input/output (TADD) pin when the serial port is operating in the TDM mode (TDM bit = 1). In TDM mode, this pin is used to input/output the address of the port. This signal goes into the high-impedance state when $\overline{\text{OFF}}$ is active (low).
FSX TFSX/TFRM	I/O/Z	Frame synchronization pulse for transmit. The falling edge of FSX/TFSX initiates the data transmit process, which begins the clocking of the XSR. Following reset, the default operating condition of FSX/TFSX is an input. This pin may be selected by software to be an output when the TXM bit in the serial control register is set to 1. This signal goes to the high-impedance state when $\overline{\text{OFF}}$ is active (low). When operating in TDM mode (TDM bit = 1), TFSX becomes TFRM, the TDM frame-synchronization pulse.
<b>TEST SIGNALS</b>		
TCK	I	Boundary scan test clock. This is normally a free-running clock with a 50% duty cycle. The changes of TAP (test access port) input signals (TMS and TDI) are clocked into the TAP controller, instruction register, or selected test data register on the rising edge of TCK. Changes at the TAP output signal (TDO) occur on the falling edge of TCK.
TDI	I	Boundary scan test data input. TDI is clocked into the selected register (instruction or data) on a rising edge of TCK.
TDO	O/Z	Boundary scan test data output. The contents of the selected register (instruction or data) is shifted out of TDO on the falling edge of TCK. TDO is in the high-impedance state except when scanning of data is in progress. This signal also goes to the high-impedance state when $\overline{\text{OFF}}$ is active (low).
TMS	I	Boundary scan test mode select. This serial control input is clocked into the test access port (TAP) controller on the rising edge of TCK.
$\overline{\text{TRST}}$	I	Boundary scan test reset. Asserting this signal gives the JTAG scan system control of the operations of the device. If this signal is not connected or is driven low, the device operates in its functional mode and the boundary scan signals are ignored.
EMU0	I/O/Z	Emulator 0. When $\overline{\text{TRST}}$ is driven low, EMU0 must be high for activation of the $\overline{\text{OFF}}$ condition (see EMU1/ $\overline{\text{OFF}}$ ). When $\overline{\text{TRST}}$ is driven high, EMU0 is used as an interrupt to or from the emulator system and is defined as input/output put via boundary scan.
EMU1/ $\overline{\text{OFF}}$	I/O/Z	Emulator 1/ $\overline{\text{OFF}}$ . When $\overline{\text{TRST}}$ is driven high, EMU1/ $\overline{\text{OFF}}$ is used as an interrupt to or from the emulator system and is defined as input/output via boundary scan. When $\overline{\text{TRST}}$ is driven low, EMU1/ $\overline{\text{OFF}}$ is configured as $\overline{\text{OFF}}$ . When the $\overline{\text{OFF}}$ signal is active (low), all output drivers are in the high-impedance state. $\overline{\text{OFF}}$ is used exclusively for testing and emulation purposes (not for multiprocessing applications). For the $\overline{\text{OFF}}$ condition, the following conditions apply: <ul style="list-style-type: none"> <li>• <math>\overline{\text{TRST}}</math> = Low</li> <li>• EMU0 = High</li> <li>• EMU1/<math>\overline{\text{OFF}}</math> = Low</li> </ul>
RESERVED‡	N/C	Reserved. This pin must be left unconnected.

† I = input, O = output, Z = high-impedance

‡ Quad flat pack only

# SMJ320C50/SMQ320C50 DIGITAL SIGNAL PROCESSOR

SGUS020 – JUNE 1996

## absolute maximum ratings over operating free-air temperature range (unless otherwise noted)†

Supply voltage range, $V_{DD}$ (see Note 1)	– 0.3 V to 7 V
Input voltage range	– 0.3 V to 7 V
Output voltage range	– 0.3 V to 7 V
Maximum operating case temperature, $T_C$	125°C
Minimum operating free-air temperature, $T_A$	– 55°C
Storage temperature range, $T_{stg}$	– 65°C to 150°C

† Stresses beyond those listed under “absolute maximum ratings” may cause permanent damage to the device. These are stress ratings only and functional operation of the device at these or any other conditions beyond those indicated under “recommended operating conditions” is not implied. Exposure to absolute-maximum-rated conditions for extended periods may affect device reliability.

NOTE 1: All voltage values are with respect to  $V_{SS}$ .

## recommended operating conditions

	MIN	NOM	MAX	UNIT
$V_{DD}$ Supply voltage	4.75	5	5.25	V
$V_{SS}$ Supply voltage		0		V
$V_{IH}$ High-level input voltage	CLKIN, CLKIN2	3.0	$V_{DD} + 0.3$	V
	CLKX, CLKR, TCLKX, TCLKR	2.5	$V_{DD} + 0.3$	V
	All others	2.2	$V_{DD} + 0.3$	V
$V_{IL}$ Low-level input voltage	– 0.3		0.6	V
$I_{OH}$ High-level output current			– 300‡	μA
$I_{OL}$ Low-level output current			2	mA
$T_C$ Operating case temperature			125	°C
$T_A$ Operating free-air temperature	– 55			°C

‡ This  $I_{OH}$  can be exceeded when using a 1-KΩ pull-down resistor on the TDM serial port TADD output, however this output still meets  $V_{OH}$  specifications under these conditions.

## electrical characteristics over recommended ranges of supply voltage and operating free-air temperature (unless otherwise noted)

PARAMETER	TEST CONDITIONS§	MIN	TYP¶	MAX	UNIT
$V_{OH}$ High-level output voltage#	$I_{OH} = \text{MAX}$	2.4	3		V
$V_{OL}$ Low-level output voltage¶	$I_{OL} = \text{MAX}$		0.3	0.6	V
$I_{OZ}$ High-impedance output current ( $V_{DD} = \text{MAX}$ )	$\overline{BR}$ (with internal pullup)	– 500		30	μA
	All others	– 30		30	
$I_I$ Input current ( $V_I = V_{SS}$ to $V_{DD}$ )	$\overline{TRST}$ (with internal pull-down)	– 30		800	μA
	TMS, TCK, TDI (with internal pullups)	– 500		30	
	X2/CLKIN	– 50		50	
	All other inputs	– 30		30	
$I_{DDC}$ Supply current, core CPU	Operating, $T_A = 25^\circ\text{C}$ , $V_{DD} = 5.25\text{ V}$ , $f_x = 50\text{ MHz}$		60	225	mA
$I_{DDP}$ Supply current, pins	Operating, $T_A = 25^\circ\text{C}$ , $V_{DD} = 5.25\text{ V}$ , $f_x = 50\text{ MHz}$		40	225	mA
$I_{DD}$ Supply current, standby	IDLE instruction, $T_A = 125^\circ\text{C}$ , $V_{DD} = 5.25\text{ V}$ , $f_x = 50\text{ MHz}$			30	mA
	IDLE2 instruction, Clocks shut off, $T_A = 125^\circ\text{C}$ , $V_{DD} = 5.25\text{ V}$			7	μA
$C_i$ Input capacitance			15	40	pF
$C_o$ Output capacitance			15	40	pF

§ For conditions shown as MIN/MAX, use the appropriate value specified under recommended operating conditions.

¶ All typical or nominal values are at  $V_{DD} = 5\text{ V}$ ,  $T_A = 25^\circ\text{C}$ .

# All input and output voltage levels are TTL-compatible. Figure 1 shows the test load circuit; Figure 2 and Figure 3 show the voltage reference levels.

|| These values are not specified pending detailed characterization.



PARAMETER MEASUREMENT INFORMATION

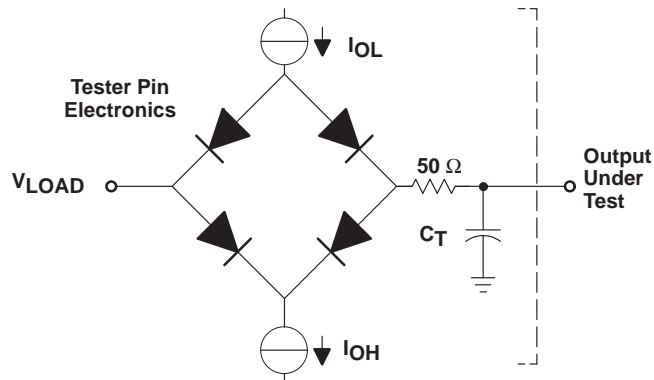

Where:  $I_{OL}$  = 2.0 mA (all outputs)  
 $I_{OH}$  = 300  $\mu$ A (all outputs)  
 $V_{LOAD}$  = 1.5 V  
 $C_T$  = 80 pF typical load circuit capacitance

Figure 1. Test Load Circuit

signal transition levels

Transistor-to-transistor logic (TTL) output levels are driven to a minimum logic-high level of 2.4 V and to a maximum logic-low level of 0.6 V. Figure 2 shows the TTL-level outputs.

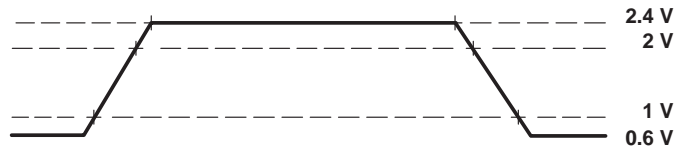

Figure 2. TTL-Level Outputs

TTL-output transition times are specified as follows:

- For a *high-to-low transition*, the level at which the output is said to be no longer high is 2 V, and the level at which the output is said to be low is 1 V.
- For a *low-to-high transition*, the level at which the output is said to be no longer low is 1 V, and the level at which the output is said to be high is 2 V.

Figure 3 shows the TTL-level inputs.



Figure 3. TTL-Level Inputs

TTL-compatible input transition times are specified as follows:

- For a *high-to-low transition* on an input signal, the level at which the input is said to be no longer high is 2 V, and the level at which the input is said to be low is 0.8 V.
- For a *low to high transition* on an input signal, the level at which the input is said to be no longer low is 0.8 V, and the level at which the input is said to be high is 2 V.

**CLOCK CHARACTERISTICS AND TIMING**

The 'C50 can use either its internal oscillator or an external frequency source for a clock. The clock mode is determined by the CLKMD1 and CLKMD2 pins. Table 1 outlines the selection of the clock mode by these pins.

**Table 1. Clock Mode Selection**

CLKMD1	CLKMD2	CLOCK SOURCE
1	0	External divide-by-one clock option
0	1	Reserved for test purposes
1	1	External divide-by-two option or internal divide-by-two clock option with an external crystal
0	0	External divide-by-two option with the internal oscillator disabled

**internal divide-by-two clock option with external crystal**

The internal oscillator is enabled by connecting a crystal across X1 and X2/CLKIN. The frequency of CLKOUT1 is one-half the crystal's oscillating frequency. The crystal should be in either fundamental or overtone operation and parallel resonant, with an effective series resistance of 30 Ω and a power dissipation of 1 mW; it should be specified at a load capacitance of 20 pF. Overtone crystals require an additional tuned LC circuit. Figure 4 shows an external crystal (fundamental frequency) connected to the on-chip oscillator.

**recommended operating conditions for internal divide-by-two clock option**

	'320C50-50			'320C50-66			UNIT
	MIN	NOM	MAX	MIN	NOM	MAX	
$f_x$ Input clock frequency	0†		50	0†		66	MHz
C1, C2 Load capacitance		10		10			pF

† This device utilizes a fully static design and therefore can operate with  $t_{c(C1)}$  approaching  $\infty$ . The device is characterized at frequencies approaching 0 Hz but is tested at a minimum of 3.3 MHz to meet device test time requirements.

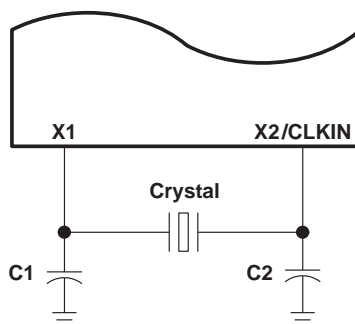

**Figure 4. Internal Clock Option**

**external divide-by-two clock option**

An external frequency source can be used by injecting the frequency directly into X2/CLKIN with X1 left unconnected, CLKMD1 set high, and CLKMD2 set high. The external frequency is divided by two to generate the internal machine cycle. The external frequency injected must conform to specifications listed in the timing requirements table.

**switching characteristics over recommended operating conditions [H = 0.5 t<sub>c(CO)</sub>]**

PARAMETER	'320C50-50			'320C50-66			UNIT
	MIN	TYP	MAX	MIN	TYP	MAX	
t <sub>c(CO)</sub> Cycle time, CLKOUT1	40	2t <sub>c(CI)</sub>	†	30	2t <sub>c(CI)</sub>	†	ns
t <sub>d(CIH-COH/L)</sub> Delay time, X2/CLKIN high to CLKOUT1 high/low	3	11	20	3	11	20	ns
t <sub>f(CO)</sub> Fall time, CLKOUT1		5			5		ns
t <sub>r(CO)</sub> Rise time, CLKOUT1		5			5		ns
t <sub>w(COL)</sub> Pulse duration, CLKOUT1 low	H - 3	H	H + 2	H - 3	H	H + 2	ns
t <sub>w(COH)</sub> Pulse duration, CLKOUT1 high	H - 3	H	H + 2	H - 3	H	H + 2	ns

**timing requirements over recommended ranges of supply voltage and operating free-air temperature**

	'320C50-50		'320C50-66		UNIT
	MIN	MAX	MIN	MAX	
t <sub>c(CI)</sub> Cycle time, X2/CLKIN	20	†	15	†	ns
t <sub>f(CI)</sub> Fall time, X2/CLKIN‡		5		5	ns
t <sub>r(CI)</sub> Rise time, X2/CLKIN‡		5		5	ns
t <sub>w(CIL)</sub> Pulse duration, X2/CLKIN low	8	†	7	†	ns
t <sub>w(CIH)</sub> Pulse duration, X2/CLKIN high	8	†	7	†	ns

† This device utilizes a fully static design and therefore can operate with t<sub>c(CI)</sub> approaching ∞. The device is characterized at frequencies approaching 0 Hz, but is tested at a minimum of 6.7 MHz to meet device test time requirements.

‡ Values derived from characterization data and not tested.

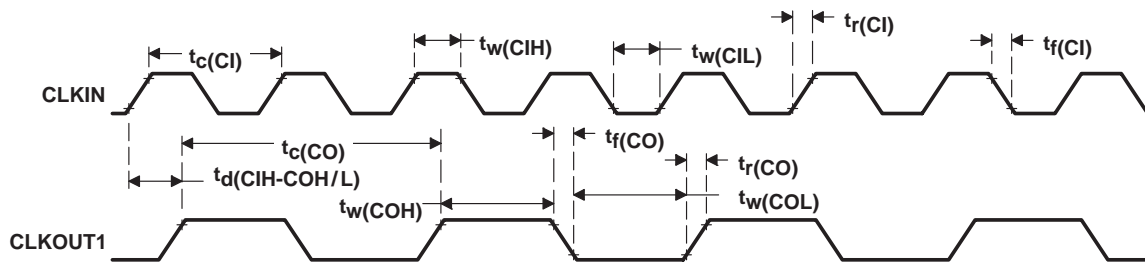

Figure 5. External Divide-by-Two Clock Timing

# SMJ320C50/SMQ320C50 DIGITAL SIGNAL PROCESSOR

SGUS020 – JUNE 1996

## external divide-by-one clock option

An external frequency source can be used by injecting the frequency directly into CLKIN2 with X1 left unconnected and X2 connected to V<sub>DD</sub>. This external frequency is divided by one to generate the internal machine cycle. The divide-by-one option is used when CLKMD1 is strapped high and CLKMD2 is strapped low. The external frequency injected must conform to specifications listed in the timing requirements table (see Figure 6 for more details).

## switching characteristics over recommended operating conditions [H = 0.5 t<sub>c(CO)</sub>]

PARAMETER	'320C50-50			'320C50-66			UNIT
	MIN	TYP	MAX	MIN	TYP	MAX	
t <sub>c(CO)</sub> Cycle time, CLKOUT1	40	t <sub>c(CI)</sub>	75†	30	t <sub>c(CI)</sub>	75†	ns
t <sub>d(C2H-COH)</sub> Delay time, CLKIN2 high to CLKOUT1 high	2	9	16	2	9	16	ns
t <sub>f(CO)</sub> Fall time, CLKOUT1		5			5		ns
t <sub>r(CO)</sub> Rise time, CLKOUT1		5			5		ns
t <sub>w(COL)</sub> Pulse duration, CLKOUT1 low	H - 3†	H	H + 2†	H - 3†	H	H + 2†	ns
t <sub>w(COH)</sub> Pulse duration, CLKOUT1 high	H - 3†	H	H + 2†	H - 3†	H	H + 2†	ns
t <sub>d(TP)</sub> Delay time, transitory phase-PLL synchronized after CLKIN2 supplied			1000t <sub>c(C2)</sub> §			1000t <sub>c(C2)</sub> §	ns

† Values assured by design and not tested

## timing requirements over recommended ranges of supply voltage and operating free-air temperature

	'320C50-50		'320C50-66		UNIT
	MIN	MAX	MIN	MAX	
t <sub>c(C2)</sub> Cycle time, CLKIN2	40	75†	30	75†	ns
t <sub>f(C2)</sub> Fall time, CLKIN2§		5		5	ns
t <sub>r(C2)</sub> Rise time, CLKIN2§		5		5	ns
t <sub>w(C2L)</sub> Pulse duration, CLKIN2 low	11	t <sub>c(C2)</sub> -11	9	t <sub>c(C2)</sub> -9	ns
t <sub>w(C2H)</sub> Pulse duration, CLKIN2 high	11	t <sub>c(C2)</sub> -11	9	t <sub>c(C2)</sub> -9	ns

† Clocks can be stopped only while the device executes IDLE2 when using the external divide-by-one clock option. Note that tp (the transitory phase) occurs when restarting clock from IDLE2 in this mode.

§ Values derived from characterization data and not tested.

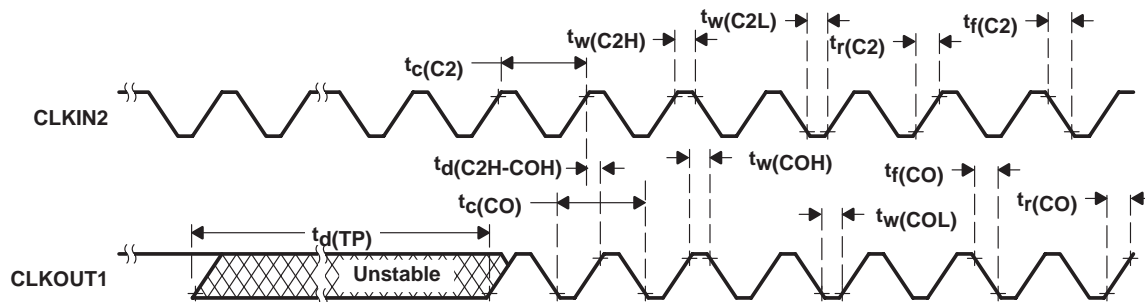

Figure 6. External Divide-by-One Clock Timing

**MEMORY AND PARALLEL I/O INTERFACE READ**

Memory and parallel I/O interface read timings are illustrated in Figure 7.

**switching characteristics over recommended operating conditions [ $H = 0.5t_c(CO)$ ]**

PARAMETER		MIN	MAX	UNIT
$t_{su}(AV-RDL)$	Setup time, address valid before $\overline{RD}$ low <sup>†</sup>	H-10 <sup>‡</sup>		ns
$t_h(RDH-AV)$	Hold time, address valid after $\overline{RD}$ high <sup>†</sup>	0 <sup>‡</sup>		ns
$t_w(RDL)$	Pulse duration, $\overline{RD}$ low <sup>§¶</sup>	H-2		ns
$t_w(RDH)$	Pulse duration, $\overline{RD}$ high <sup>§¶</sup>	H-2		ns
$t_d(RDH-WEL)$	Delay time, $\overline{RD}$ high to $\overline{WE}$ low	2H-5		ns

<sup>†</sup> A15-A0,  $\overline{PS}$ ,  $\overline{DS}$ ,  $\overline{IS}$ ,  $\overline{R/W}$ , and  $\overline{BR}$  timings are all included in timings referenced as address.

<sup>‡</sup> See Figure 8 for address-bus timing variation with load capacitance.

<sup>§</sup>  $\overline{STRB}$  and  $\overline{RD}$  timing is -3/+5 ns from CLKOUT1 timing on read cycles, following the first cycle after reset, which is always a seven wait-state cycle.

<sup>¶</sup> Values are derived from characterization data and are not tested.

**timing requirements over recommended ranges of supply voltage and operating free-air temperature [ $H = 0.5t_c(CO)$ ]**

		MIN	MAX	UNIT
$t_a(RDAV)$	Access time, read data valid from address valid		2H-15 <sup>‡</sup>	ns
$t_a(RDL-RD)$	Access time, read data valid after $\overline{RD}$ low		H-10	ns
$t_{su}(RD-RDH)$	Setup time, read data valid before $\overline{RD}$ high	10		ns
$t_h(RDH-RD)$	Hold time, read data valid after $\overline{RD}$ high	0		ns

<sup>‡</sup> See Figure 8 for address-bus timing variation with load capacitance.

# SMJ320C50/SMQ320C50 DIGITAL SIGNAL PROCESSOR

SGUS020 – JUNE 1996

## MEMORY AND PARALLEL I/O INTERFACE WRITE

Memory and parallel I/O interface read timings are illustrated in Figure 7.

### switching characteristics over recommended operating conditions [ $H = 0.5t_{c(CO)}$ ]

PARAMETER	MIN	MAX	UNIT
$t_{su}(AV-WEL)$	$H - 5^{\ddagger}$		ns
$t_h(WEH-AV)$	$H - 10^{\ddagger}$		ns
$t_w(WEL)$	$2H - 4$	$2H + 2^{\parallel}$	ns
$t_w(WEH)$	$2H - 2$		ns
$t_d(WEH-RDL)$	$3H - 10$		ns
$t_{su}(WDV-WEH)$	$2H - 20$	$2H^{\parallel\#}$	ns
$t_h(WEH-WDV)$	$H - 5$	$H + 10^{\parallel}$	ns
$t_{en}(WE-BUd)$	$-5^{\parallel}$		ns

<sup>†</sup> A15–A0, PS, DS, IS, R/W, and BR timings are all included in timings referenced as address.

<sup>‡</sup> See Figure 8 for address bus timing variation with load capacitance.

<sup>§</sup> STRB and WE edges are 0–4 ns from CLKOUT1 edges on writes. Rising and falling edges of these signals track each other; tolerance of resulting pulse durations is  $\pm 2$  ns, not  $\pm 4$  ns.

<sup>¶</sup> Values derived from characterization data and are not tested.

<sup>#</sup> This value holds true for zero or one wait state only.

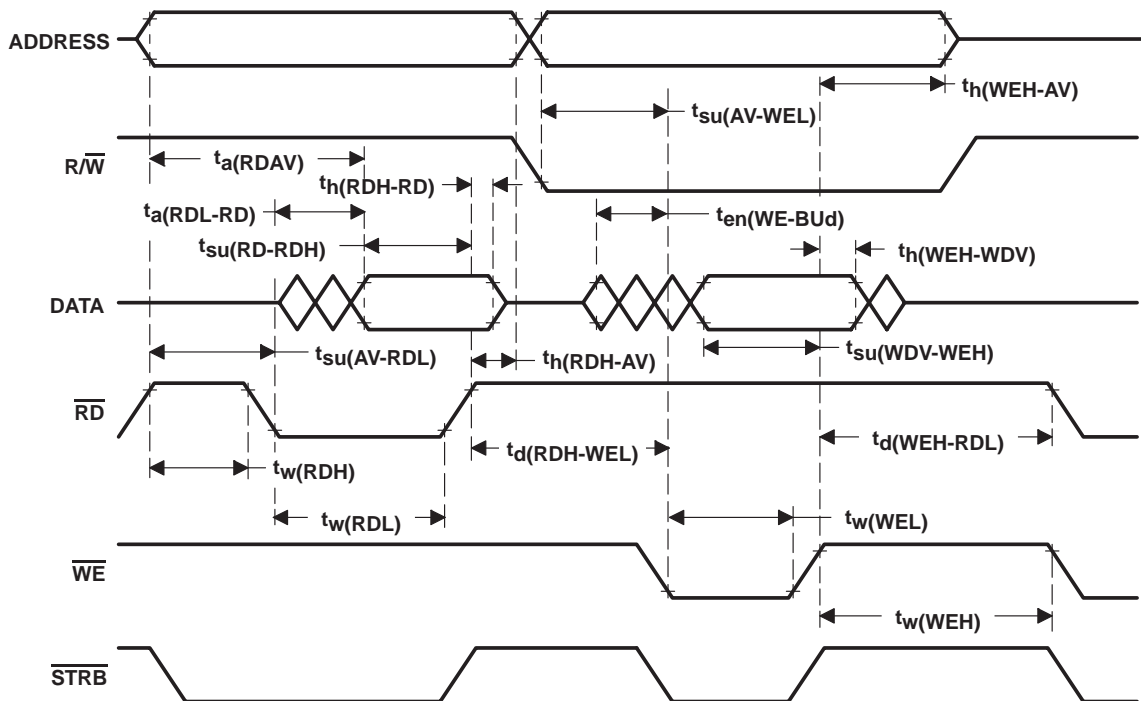

NOTE A: All timings are for 0 wait states. However, external writes always require two cycles to prevent external bus conflicts. The above diagram illustrates a one-cycle read and a two-cycle write and is not drawn to scale. All external writes immediately preceded by an external read or immediately followed by an external read require three machine cycles.

Figure 7. Memory and Parallel I/O Interface Read and Write Timing



POST OFFICE BOX 1443 • HOUSTON, TEXAS 77251-1443



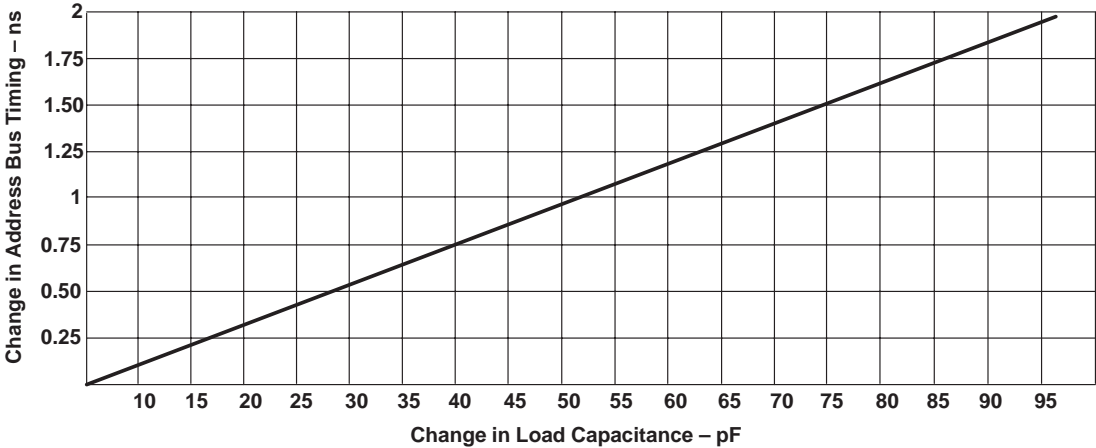

Figure 8. Address Bus Timing Variation With Load Capacitance

READY TIMING FOR EXTERNALLY GENERATED WAIT STATES

timing requirements over recommended ranges of supply voltage and operating free-air temperature

		MIN	MAX	UNIT
$t_{su}(RY-COH)$	Setup time, READY before CLKOUT1 rises	10		ns
$t_h(CO-RYH)$	Hold time, READY after CLKOUT1 rises	0		ns
$t_{su}(RY-RDL)$	Setup time, READY before $\overline{RD}$ falls	10		ns
$t_h(RDL-RY)$	Hold time, READY after $\overline{RD}$ falls	0		ns
$t_v(WEL-RY)$	Valid time, READY after $\overline{WE}$ falls	H - 15		ns
$t_h(WEL-RY)$	Hold time, READY after $\overline{WE}$ falls	H + 5		ns

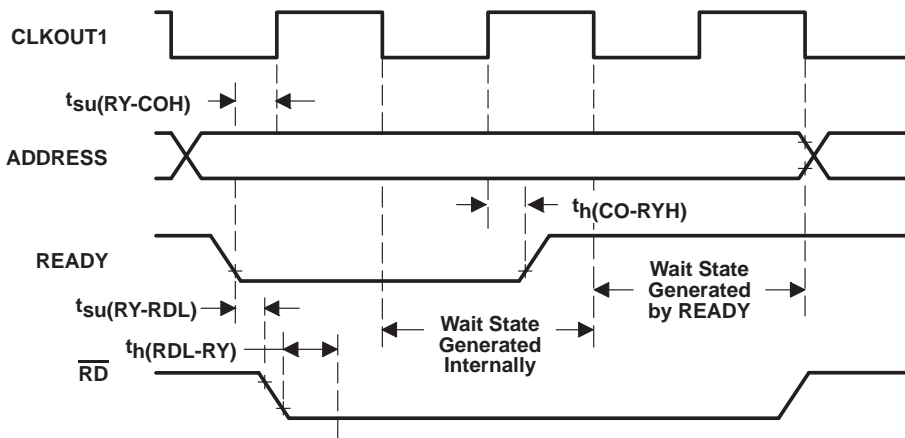

Figure 9. Ready Timing for Externally Generated Wait States During an External Read Cycle

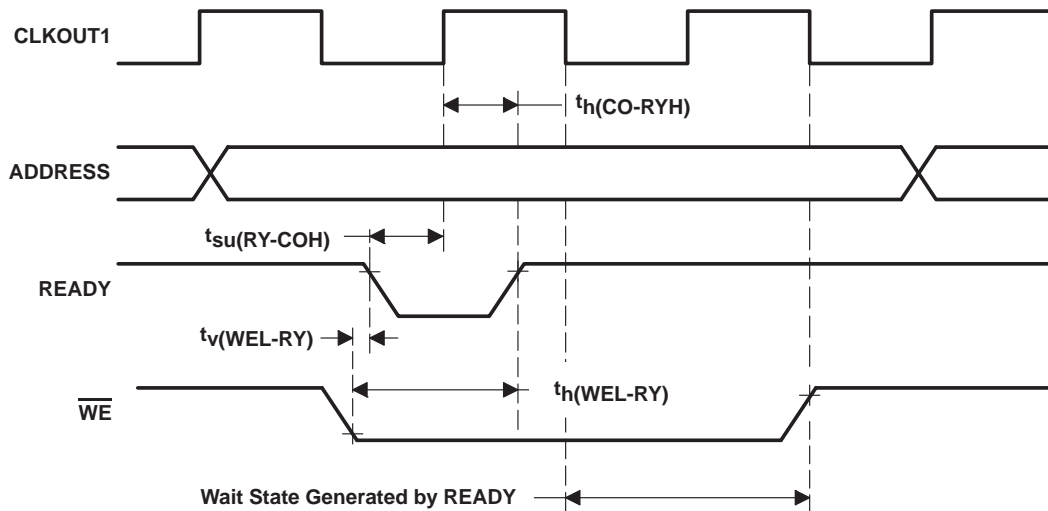

Figure 10. Ready Timing for Externally Generated Wait States During an External Write Cycle

RESET, INTERRUPT, AND  $\overline{\text{BIO}}$

timing requirements over recommended ranges of supply voltage and operating free-air temperature [ $H = 0.5t_c(\text{CO})$ ]

PARAMETER	MIN	MAX	UNIT
$t_{\text{su}}(\text{IN-COL})$	15		ns
$t_{\text{h}}(\text{COL-IN})$	0		ns
$t_{\text{w}}(\text{INL})\text{SYN}$	$4H+15\ddagger$		ns
$t_{\text{w}}(\text{INH})\text{SYN}$	$2H+15\ddagger\text{\S}$		ns
$t_{\text{w}}(\text{INL})\text{ASY}$	$6H+15\ddagger$		ns
$t_{\text{w}}(\text{INH})\text{ASY}$	$4H+15\ddagger$		ns
$t_{\text{su}}(\text{RS-X2L})$	10		ns
$t_{\text{w}}(\text{RSL})$	12H		ns
$t_{\text{d}}(\text{RSH})$	34H		ns
$t_{\text{w}}(\text{BIL})\text{SYN}$	15		ns
$t_{\text{w}}(\text{BIL})\text{ASY}$	$H+15$		ns
$t_{\text{su}}(\text{BI-COL})$	15		ns
$t_{\text{h}}(\text{COL-BI})$	0		ns

† These parameters must be met to use the synchronous timings. Both reset and the interrupts can operate asynchronously. The pulse durations require an extra half-cycle to assure internal synchronization.

‡ If in IDLE2, add 4H to these timings.

§ Values are specified by design and not tested.

¶ Values derived from characterization data and are not tested.

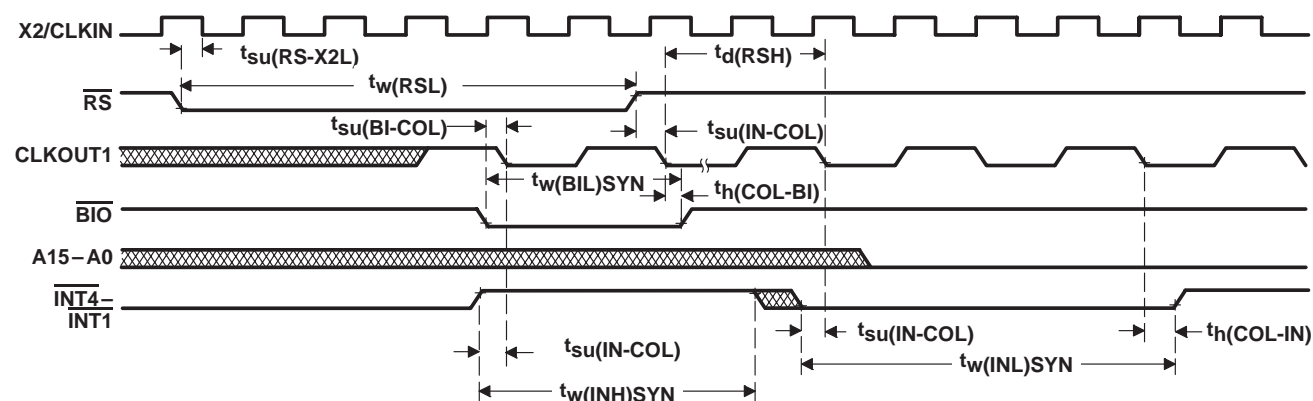

Figure 11. Reset, Interrupt, and  $\overline{\text{BIO}}$  Timings

# SMJ320C50/SMQ320C50 DIGITAL SIGNAL PROCESSOR

SGUS020 – JUNE 1996

## INSTRUCTION ACQUISITION ( $\overline{\text{IAQ}}$ ), INTERRUPT ACKNOWLEDGE ( $\overline{\text{IACK}}$ ), EXTERNAL FLAG (XF), AND TOUT

switching characteristics over recommended operating conditions [ $H = 0.5t_c(CO)$ ]

PARAMETER		MIN	MAX	UNIT
$t_{su}(AV-IQL)$	Setup time, address valid before $\overline{\text{IAQ}}$ low <sup>†</sup>	H-12 <sup>‡</sup>		ns
$t_h(IQL-AV)$	Hold time, address valid after $\overline{\text{IAQ}}$ low	H-10 <sup>‡</sup>		ns
$t_w(IQL)$	Pulse duration, $\overline{\text{IAQ}}$ low	H-10 <sup>‡</sup>		ns
$t_d(CO-TU)$	Delay time, CLKOUT1 falling to TOUT	-6	6	ns
$t_{su}(AV-IKL)$	Setup time, address valid before $\overline{\text{IACK}}$ low <sup>§</sup>	H-12 <sup>‡</sup>		ns
$t_h(IKH-AV)$	Hold time, address valid after $\overline{\text{IACK}}$ high <sup>§</sup>	H-10 <sup>‡</sup>		ns
$t_w(IKL)$	Pulse duration, $\overline{\text{IACK}}$ low	H-10 <sup>‡</sup>		ns
$t_w(TUH)$	Pulse duration, TOUT high	2H-12		ns
$t_d(CO-XFV)$	Delay time, XF valid after CLKOUT1	0	12	ns

<sup>†</sup>  $\overline{\text{IAQ}}$  goes low during an instruction acquisition. It goes low only on the first cycle of the read when wait states are used. The falling edge should be used to latch the valid address. The AVIS bit in the PMST register must be set to zero for the address to be valid when the instruction being addressed resides in on-chip memory.

<sup>‡</sup> Valid only if the external address reflects the current instruction activity (that is, code is executing on chip with no external bus cycles and AVIS is on, or code is executing off-chip).

<sup>§</sup>  $\overline{\text{IACK}}$  goes low during the fetch of the first word of the interrupt vector. It goes low only on the first cycle of the read when wait states are used. Address pins A1 – A4 can be decoded at the falling edge to identify the interrupt being acknowledged. The AVIS bit in the PMST register must be set to zero for the address to be valid when the vectors reside in on-chip memory.

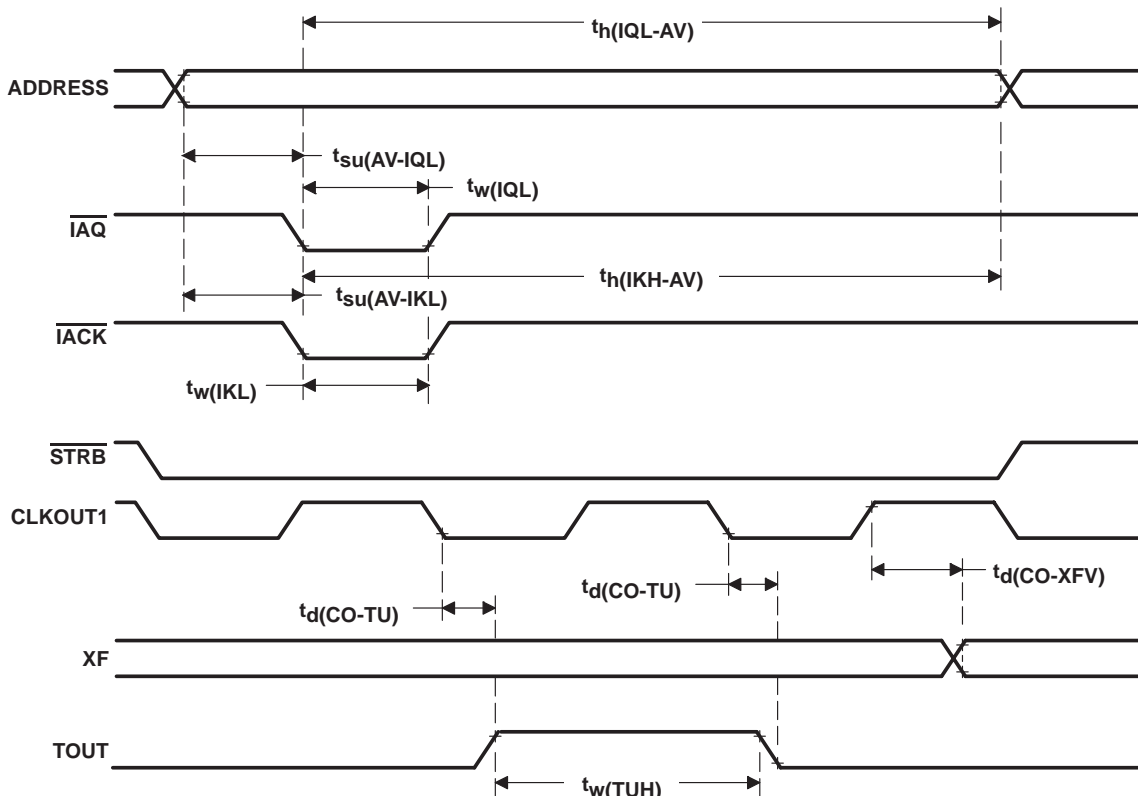

NOTE:  $\overline{\text{IAQ}}$  and  $\overline{\text{IACK}}$  are not affected by wait states.

Figure 12.  $\overline{\text{IAQ}}$ ,  $\overline{\text{IACK}}$ , and XF Timings Example With Two External Wait States



POST OFFICE BOX 1443 • HOUSTON, TEXAS 77251-1443

EXTERNAL DMA TIMING

switching characteristics over recommended operating conditions [ $H = 0.5t_{c(CO)}$ ] (see Note 2)

PARAMETER	MIN	MAX	UNIT
$t_d(\text{HOL-HAL})$ Delay time, $\overline{\text{HOLD}}$ low to $\overline{\text{HOLDA}}$ low	4H	‡	ns
$t_d(\text{HOH-HAH})$ Delay time, $\overline{\text{HOLD}}$ high before $\overline{\text{HOLDA}}$ high	2H		ns
$t_{dis}(\text{AZ-HAL})$ Disable time, address in the high-impedance state before $\overline{\text{HOLDA}}$ low <sup>§</sup>	H–15†		ns
$t_{en}(\text{HAH-Ad})$ Enable time, $\overline{\text{HOLDA}}$ high to address driven	H–5†		ns
$t_d(\text{XBL-IQL})$ Delay time, $\overline{\text{XBR}}$ low to $\overline{\text{IAQ}}$ low	4H†	6H†	ns
$t_d(\text{XBH-IQH})$ Delay time, $\overline{\text{XBR}}$ high to $\overline{\text{IAQ}}$ high	2H†	4H†	ns
$t_d(\text{XSL-RDV})$ Delay time, read data valid after $\overline{\text{XSTRB}}$ low		40	ns
$t_h(\text{XSH-RD})$ Hold time, read data after $\overline{\text{XSTRB}}$ high	0		ns
$t_{en}(\text{IQL-RDd})$ Enable time, $\overline{\text{IAQ}}$ low to read data driven <sup>¶</sup>	0†	2H†	ns
$t_{dis}(\text{W})$ Disable time, $\overline{\text{XR}/\overline{\text{W}}}$ low to data in the high-impedance state	0†	15†	ns
$t_{dis}(\text{I-D})$ Disable time, $\overline{\text{IAQ}}$ high to data in the high-impedance state		H†	ns
$t_{en}(\text{D-XRH})$ Enable time, data from $\overline{\text{XR}/\overline{\text{W}}}$ going high		4†	ns

† Values derived from characterization data and are not tested.

‡  $\overline{\text{HOLD}}$  is not acknowledged until current external access request is complete.

§ This parameter includes all memory control lines.

¶ This parameter refers to the delay between the time the condition ( $\overline{\text{IAQ}} = 0$  and  $\overline{\text{XR}/\overline{\text{W}}} = 1$ ) is satisfied and the time that the SMJ320C50x data lines become valid.

NOTE 2: X preceding a name refers to the external drive of the signal.

timing requirements over recommended ranges of supply voltage and operating free-air temperature

	MIN	MAX	UNIT
$t_d(\text{HAL-XBL})$ Delay time, $\overline{\text{HOLDA}}$ low to $\overline{\text{XBR}}$ low <sup>#</sup>	0 <sup>#</sup>		ns
$t_d(\text{IQL-XSL})$ Delay time, $\overline{\text{IAQ}}$ low to $\overline{\text{XSTRB}}$ low <sup>#</sup>	0 <sup>#</sup>		ns
$t_{su}(\text{AV-XSL})$ Setup time, Xaddress valid before $\overline{\text{XSTRB}}$ low	15		ns
$t_{su}(\text{DV-XSL})$ Setup time, Xdata valid before $\overline{\text{XSTRB}}$ low	15		ns
$t_h(\text{XSL-D})$ Hold time, Xdata hold after $\overline{\text{XSTRB}}$ low	15		ns
$t_h(\text{XSL-WA})$ Hold time, write Xaddress hold after $\overline{\text{XSTRB}}$ low	15		ns
$t_w(\text{XSL})$ Pulse duration, $\overline{\text{XSTRB}}$ low	45		ns
$t_w(\text{XSH})$ Pulse duration, $\overline{\text{XSTRB}}$ high	45		ns
$t_{su}(\text{RW-XSL})$ Setup time, $\overline{\text{R}/\overline{\text{W}}}$ valid before $\overline{\text{XSTRB}}$ low	20		ns
$t_h(\text{XSH-RA})$ Hold time, read Xaddress after $\overline{\text{XSTRB}}$ high	0		ns

<sup>#</sup>  $\overline{\text{XBR}}$ ,  $\overline{\text{XR}/\overline{\text{W}}}$ , and  $\overline{\text{XSTRB}}$  lines should be pulled up with a 10-k $\Omega$  resistor to assure that they are in an inactive (high) state during the transition period between the SMJ320C50x driving them and the external circuit driving them.

NOTE 2: X preceding a name refers to the external drive of the signal.



# SMJ320C50/SMQ320C50 DIGITAL SIGNAL PROCESSOR

SGUS020 – JUNE 1996

## EXTERNAL DMA

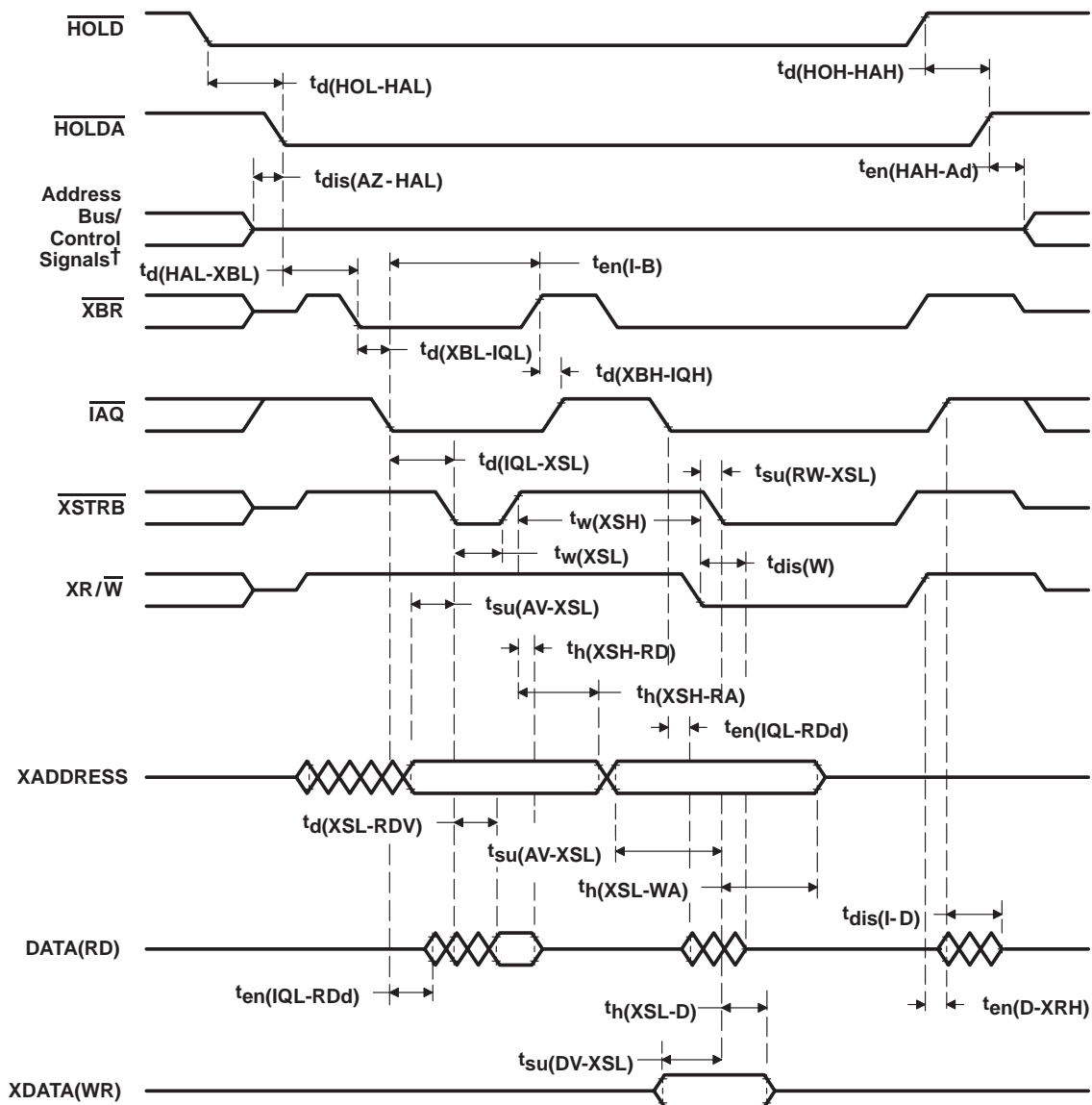

† A15–A0,  $\overline{\text{PS}}$ ,  $\overline{\text{DS}}$ ,  $\overline{\text{IS}}$ ,  $\text{R}/\overline{\text{W}}$ , and  $\overline{\text{BR}}$  timings are all included in timings referenced as address bus/control signals.

Figure 13. External DMA Timing

SERIAL-PORT RECEIVE

timing requirements over recommended ranges of supply voltage and operating free-air temperature [ $H = 0.5t_c(CO)$ ]

PARAMETER		MIN	MAX	UNIT
$t_c(SCK)$	Cycle time, serial-port clock	5.2H	†	ns
$t_f(SCK)$	Fall time, serial-port clock		‡	ns
$t_r(SCK)$	Rise time, serial-port clock		‡	ns
$t_w(SCK)$	Pulse duration, serial-port clock low/high	2.1H		ns
$t_{su}(FS-CK)$	Setup time, FSR before CLKR falling edge	10		ns
$t_h(CK-FS)$	Hold time, FSR after CLKR falling edge	10		ns
$t_{su}(DR-CK)$	Setup time, DR before CLKR falling edge	10		ns
$t_h(CK-DR)$	Hold time, DR after CLKR falling edge	10		ns

† The serial-port design is fully static and therefore can operate with  $t_c(SCK)$  approaching  $\infty$ . It is characterized approaching an input frequency of 0 Hz but tested at a much higher frequency to minimize test time.

‡ Values derived from characterization data and are not tested.

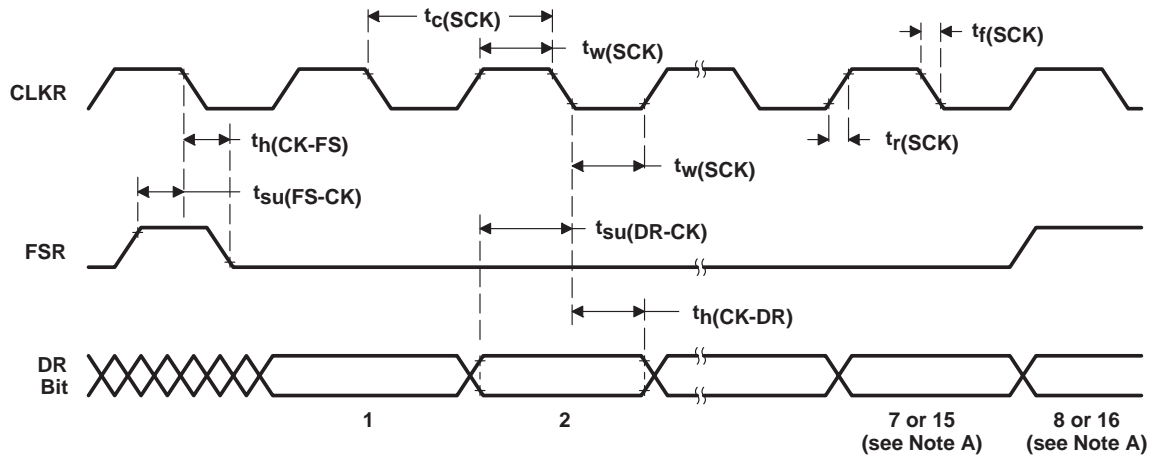

NOTE A: Depending on whether information is sent in an 8-bit or 16-bit packet.

Figure 14. Serial-Port Receive Timing

# SMJ320C50/SMQ320C50 DIGITAL SIGNAL PROCESSOR

SGUS020 – JUNE 1996

## SERIAL-PORT TRANSMIT, EXTERNAL CLOCKS AND EXTERNAL FRAMES

switching characteristics over recommended operating conditions (see Note 3)

PARAMETER	MIN	MAX	UNIT
$t_d(\text{CXH-DXV})$ Delay time, DX valid after CLKX high		25	ns
$t_{\text{dis}}(\text{CXH-DX})$ Disable time, DX valid after CLKX high		40†	ns
$t_h(\text{CXH-DXV})$ Hold time, DX valid after CLKX high	-5		ns

timing requirements over recommended ranges of supply voltage and operating free-air temperature [ $H = 0.5t_c(\text{CO})$ ] (see Note 3)

	MIN	MAX	UNIT
$t_c(\text{SCK})$ Cycle time, serial-port clock	5.2H	‡	ns
$t_f(\text{SCK})$ Fall time, serial-port clock		8†	ns
$t_r(\text{SCK})$ Rise time, serial-port clock		8†	ns
$t_w(\text{SCK})$ Pulse duration, serial-port clock low/high	2.1H		ns
$t_d(\text{CXH-FXH})$ Delay time, FSX after CLKX high edge		2H-8	ns
$t_h(\text{CXL-FXL})$ Hold time, FSX after CLKX falling edge	10		ns
$t_h(\text{CXH-FXL})$ Hold time, FSX after CLKX high edge		2H-8†§	ns

† Values derived from characterization data and are not tested.

‡ The serial-port design is fully static and therefore can operate with  $t_c(\text{SCK})$  approaching  $\infty$ . It is characterized approaching an input frequency of 0 Hz but tested at a much higher frequency to minimize test time.

§ If the FSX pulse does not meet this specification, the first bit of serial data will be driven on the DX pin until the falling edge of FSX. After the falling edge of FSX, data will be shifted out on the DX pin. The transmit-buffer-empty interrupt will be generated when the  $t_h(\text{FS})$  and  $t_h(\text{FS})_H$  specification is met.

NOTE 3: Internal clock with external FSX and vice versa are also allowable. However, FSX timings to CLKX are always defined depending on the source of FSX, and CLKX timings are always dependent upon the source of CLKX. Specifically, the relationship of FSX to CLKX is independent of the source of CLKX.

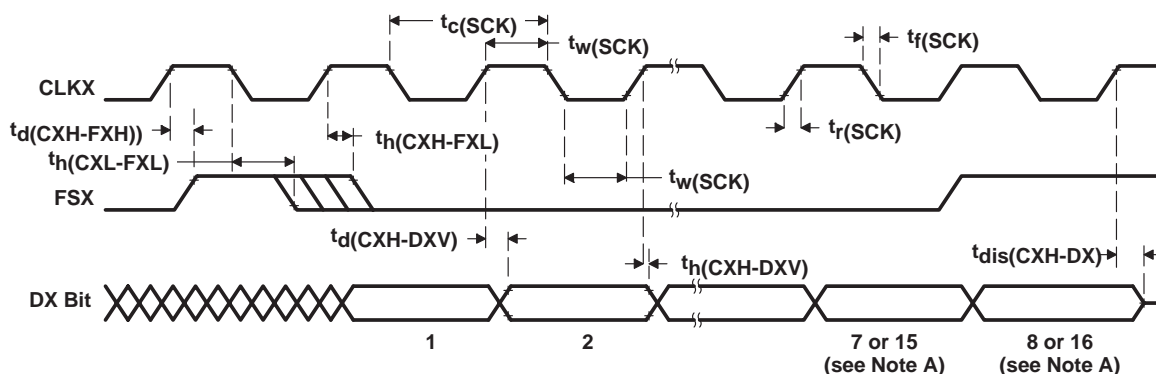

NOTE A: Depending on whether information is sent in an 8-bit or 16-bit packet.

Figure 15. Serial-Port Transmit Timing of External Clocks and External Frames



POST OFFICE BOX 1443 • HOUSTON, TEXAS 77251-1443



**SERIAL-PORT TRANSMIT, INTERNAL CLOCKS AND INTERNAL FRAMES**

switching characteristics over recommended operating conditions [ $H = 0.5t_c(CO)$ ] (see Note 3)

PARAMETER		MIN	TYP	MAX	UNIT
$t_d(CX-FX)$	Delay time, CLKX rising to FSX			25	ns
$t_d(CX-DX)$	Delay time, CLKX rising to DX			25	ns
$t_{dis}(CX-DX)$	Disable time, CLKX rising to DX			40†	ns
$t_c(SCK)$	Cycle time, serial-port clock		8H		ns
$t_f(SCK)$	Fall time, serial-port clock		5		ns
$t_r(SCK)$	Rise time, serial-port clock		5		ns
$t_w(SCK)$	Pulse duration, serial-port clock low/high	4H – 20			ns
$t_h(CXH-DXV)$	Hold time, DX valid after CLKX high	– 6			ns

† Values derived from characterization and not tested.

NOTE 3: Internal clock with external FSX and vice versa are also allowable. However, FSX timings to CLKX are always defined depending on the source of FSX, and CLKX timings are always dependent upon the source of CLKX. Specifically, the relationship of FSX to CLKX is independent of the source of CLKX.

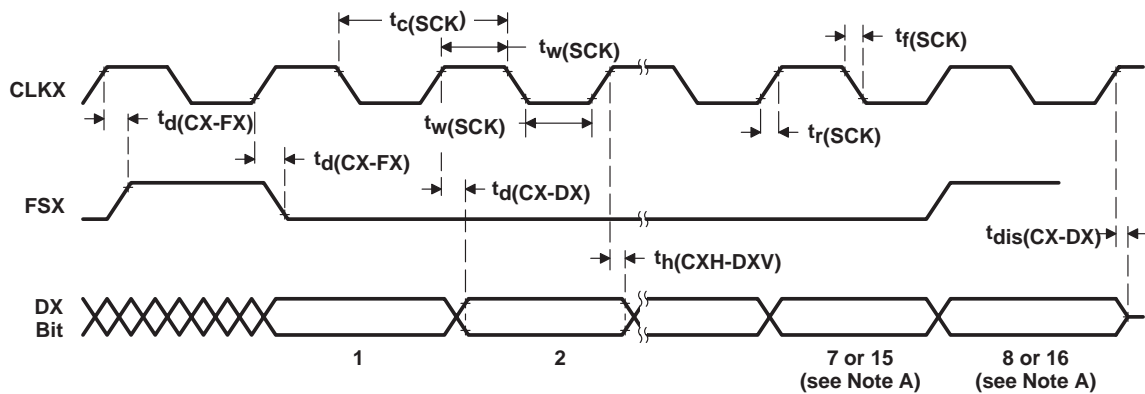

NOTE A: Depending on whether information is sent in an 8-bit or 16-bit packet.

**Figure 16. Serial-Port Transmit Timing of Internal Clocks and Internal Frames**

# SMJ320C50/SMQ320C50 DIGITAL SIGNAL PROCESSOR

SGUS020 – JUNE 1996

## SERIAL-PORT RECEIVE TIMING IN TDM MODE

timing requirements over recommended ranges of supply voltage and operating free-air temperature [ $H = 0.5t_c(CO)$ ]

		MIN	MAX	UNIT
$t_c(SCK)$	Cycle time, serial-port clock	5.2H	†	ns
$t_f(SCK)$	Fall time, serial-port clock		8‡	ns
$t_r(SCK)$	Rise time, serial-port clock		8‡	ns
$t_w(SCK)$	Pulse duration, serial-port clock low/high	2.1H		ns
$t_{su}(TD-TCH)$	Setup time, TDAT/TADD before TCLK rising	30		ns
$t_h(TCH-TD)$	Hold time, TDAT/TADD after TCLK rising	-3		ns
$t_{su}(TA-TCH)$	Setup time, TDAT/TADD before TCLK rising§	20		ns
$t_h(TCH-TA)$	Hold time, TDAT/TADD after TCLK rising§	-3		ns
$t_{su}(TF-TCH)$	Setup time, TRFM before TCLK rising edge¶	10		ns
$t_h(TCH-TF)$	Hold time, TRFM after TCLK rising edge¶	10		ns

† The serial-port design is fully static and therefore can operate with  $t_c(SCK)$  approaching  $\infty$ . It is characterized approaching an input frequency of 0 Hz but tested at a much higher frequency to minimize test time.

‡ Values derived from characterization data and are not tested.

§ These parameters apply only to the first bits in the serial bit string.

¶ TFRM timing and waveforms shown in Figure 17 are for external TFRM. TFRM also can be configured as internal. The TFRM internal case is illustrated in the transmit timing diagram in Figure 18.

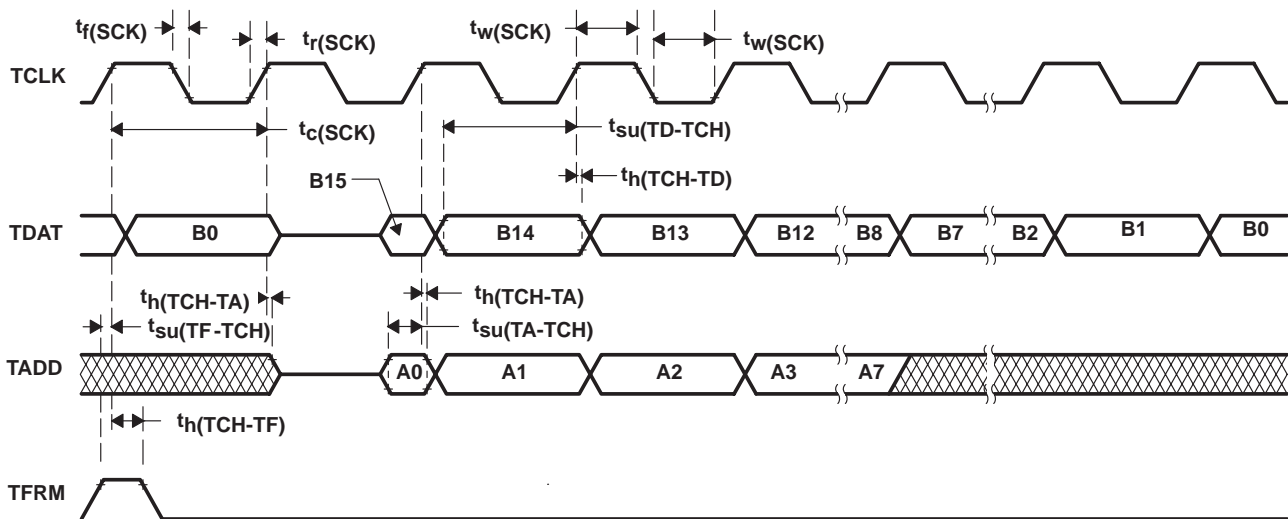

Figure 17. Serial-Port Receive Timing in TDM Mode

SERIAL-PORT TRANSMIT TIMING IN TDM MODE

switching characteristics over recommended operating conditions [ $H = 0.5t_{c(CO)}$ ]

PARAMETER	MIN	MAX	UNIT
$t_h(TCH-TDV)$ Hold time, TDAT/TADD valid after TCLK rising	0		ns
$t_d(TCH-TFV)$ Delay time, TFRM valid after TCLK rising†	H	3H+10	ns
$t_d(TC-TDV)$ Delay time, TCLK to valid TDAT/TADD		20	ns

† TFRM timing and waveforms shown in Figure 18 are for internal TFRM. TFRM can also be configured as external, and the TFRM external case is illustrated in the receive timing diagram in Figure 17.

timing requirements over recommended ranges of supply voltage and operating free-air temperature [ $(H = 0.5t_{c(CO)})$ ]

	MIN	TYP	MAX	UNIT
$t_c(SCK)$ Cycle time, serial-port clock	5.2H	8H‡	§	ns
$t_f(SCK)$ Fall time, serial-port clock			8¶	ns
$t_r(SCK)$ Rise time, serial-port clock			8¶	ns
$t_w(SCK)$ Pulse duration, serial-port clock low/high	2.1H			ns

‡ When SCK is generated internally.

§ The serial-port design is fully static and therefore can operate with  $t_c(SCK)$  approaching  $\infty$ . It is characterized approaching an input frequency of 0 Hz but tested at a much higher frequency to minimize test time.

¶ Values derived from characterization data and are not tested.

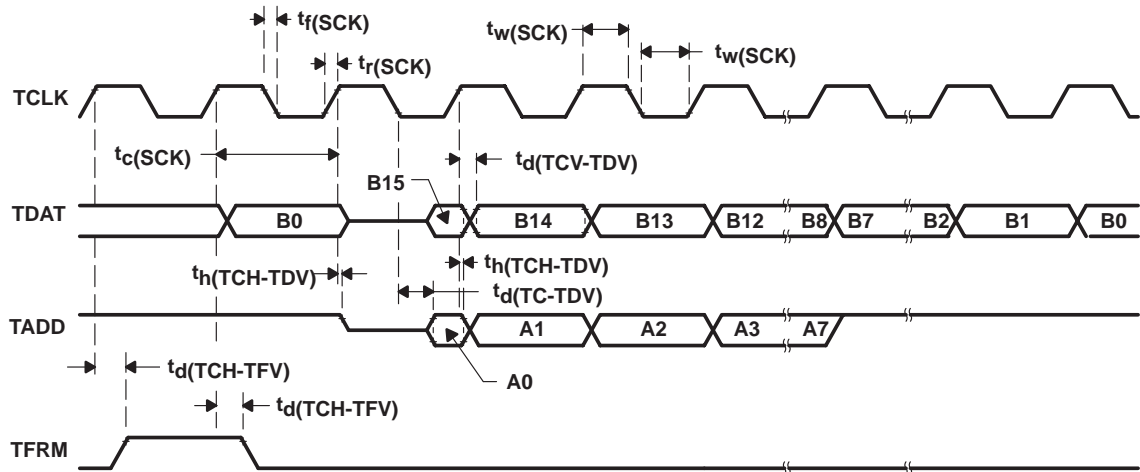

Figure 18. Serial-Port Transmit Timing in TDM Mode

**SMJ320C50/SMQ320C50  
DIGITAL SIGNAL PROCESSOR**

SGUS020 – JUNE 1996

**MECHANICAL DATA**

**HFG (S-CQFP-F132)**

**CERAMIC QUAD FLATPACK WITH TIE-BAR**

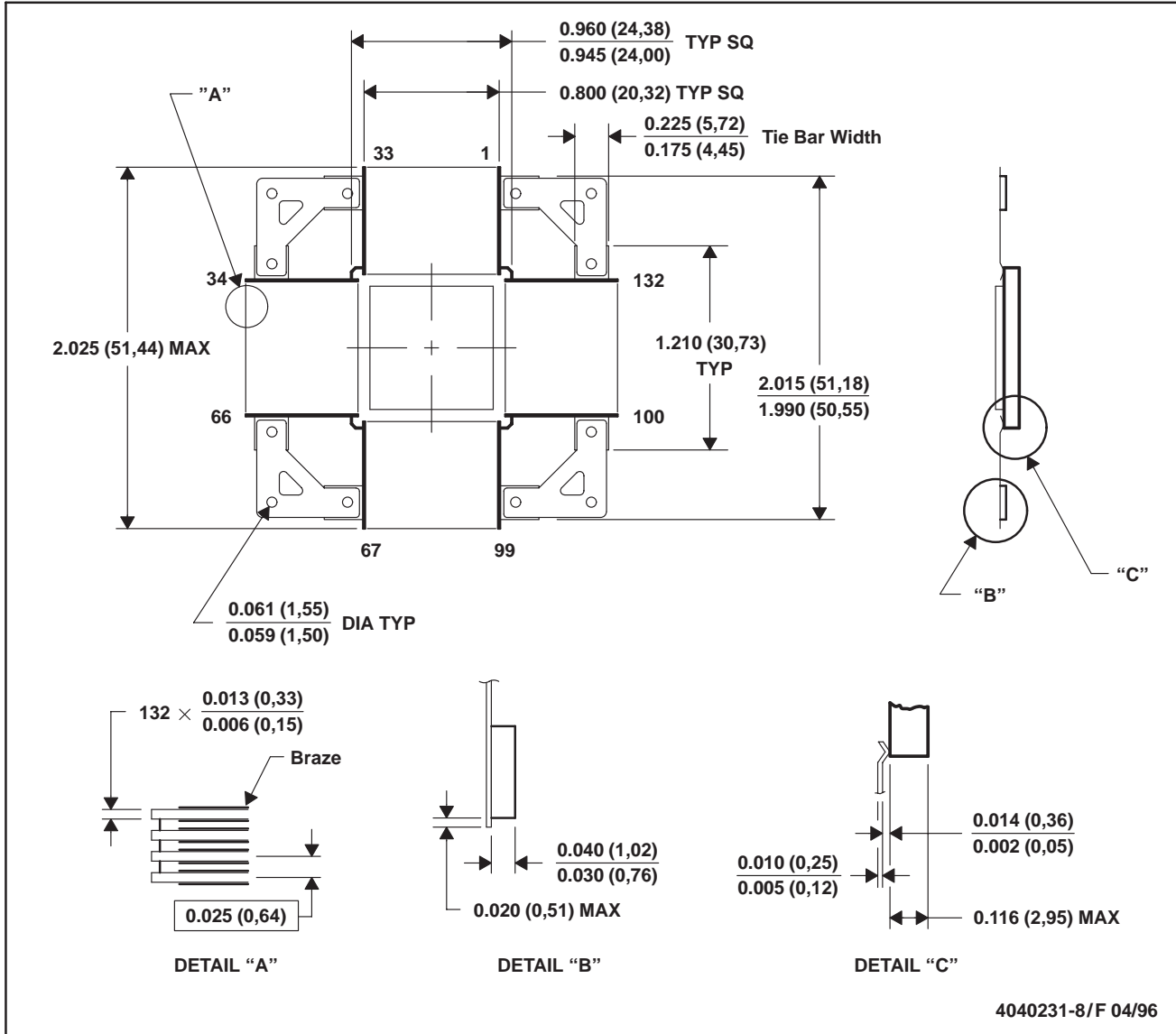

- NOTES: A. All linear dimensions are in inches (millimeters)..  
 B. This drawing is subject to change without notice.  
 C. Ceramic quad flatpack with flat leads brazed to non-conductive tie bar carrier.  
 D. This package can be hermetically sealed with a metal lid.  
 E. The terminals will be gold plated.



POST OFFICE BOX 1443 • HOUSTON, TEXAS 77251-1443

# SMJ320C50/SMQ320C50 DIGITAL SIGNAL PROCESSOR

SGUS020 – JUNE 1996

## MECHANICAL DATA

GFA (S-CPGA-P141)

CERAMIC PIN GRID ARRAY PACKAGE

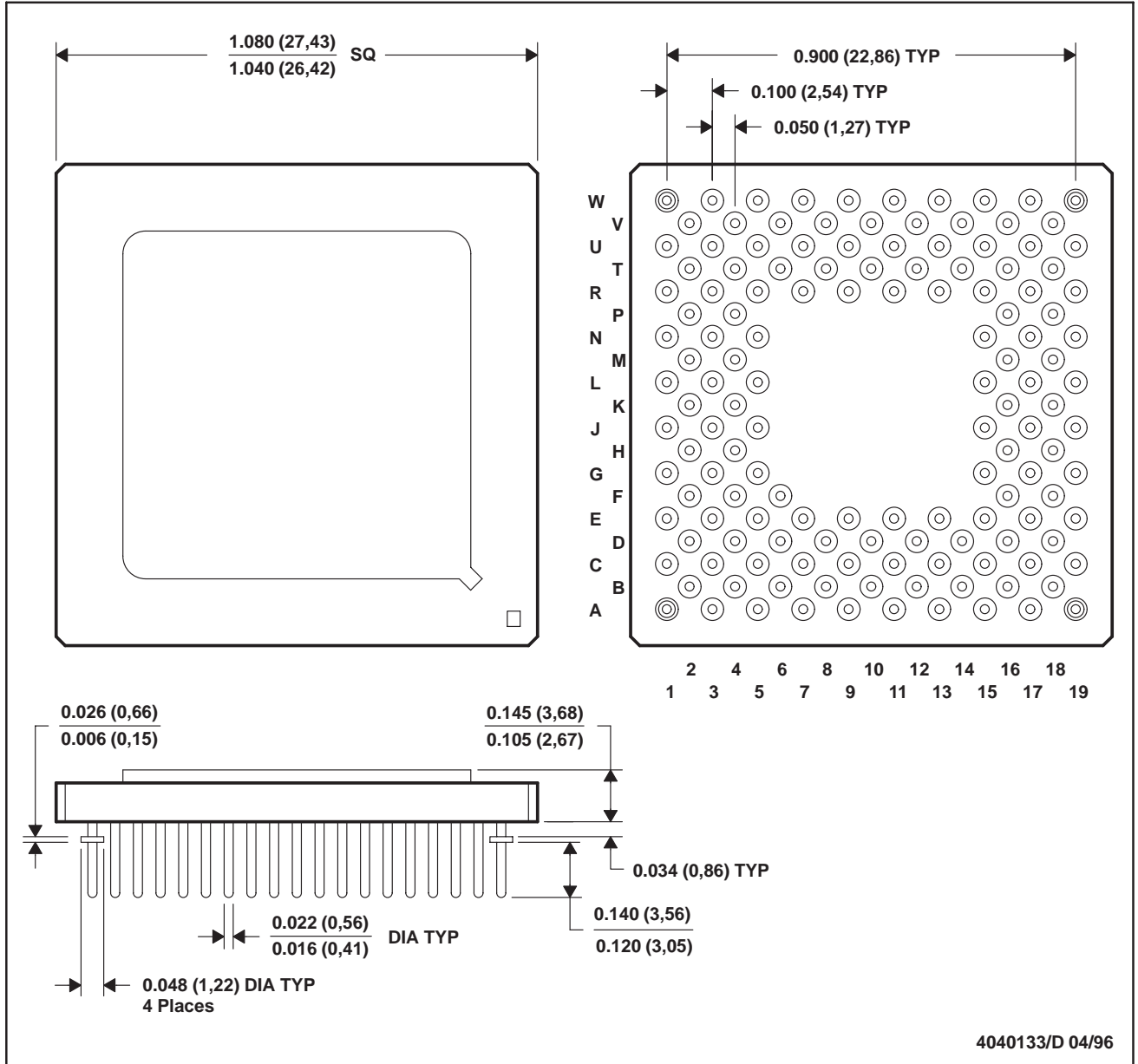

- NOTES: A. All linear dimensions are in inches (millimeters).  
B. This drawing is subject to change without notice.  
C. Falls within JEDEC MO-128

 **TEXAS  
INSTRUMENTS**

POST OFFICE BOX 1443 • HOUSTON, TEXAS 77251-1443

# SMJ320C50/SMQ320C50 DIGITAL SIGNAL PROCESSOR

SGUS020 – JUNE 1996

## MECHANICAL DATA

PQ (S-PQFP-G<sup>\*\*\*</sup>)

PLASTIC QUAD FLATPACK

100 LEAD SHOWN

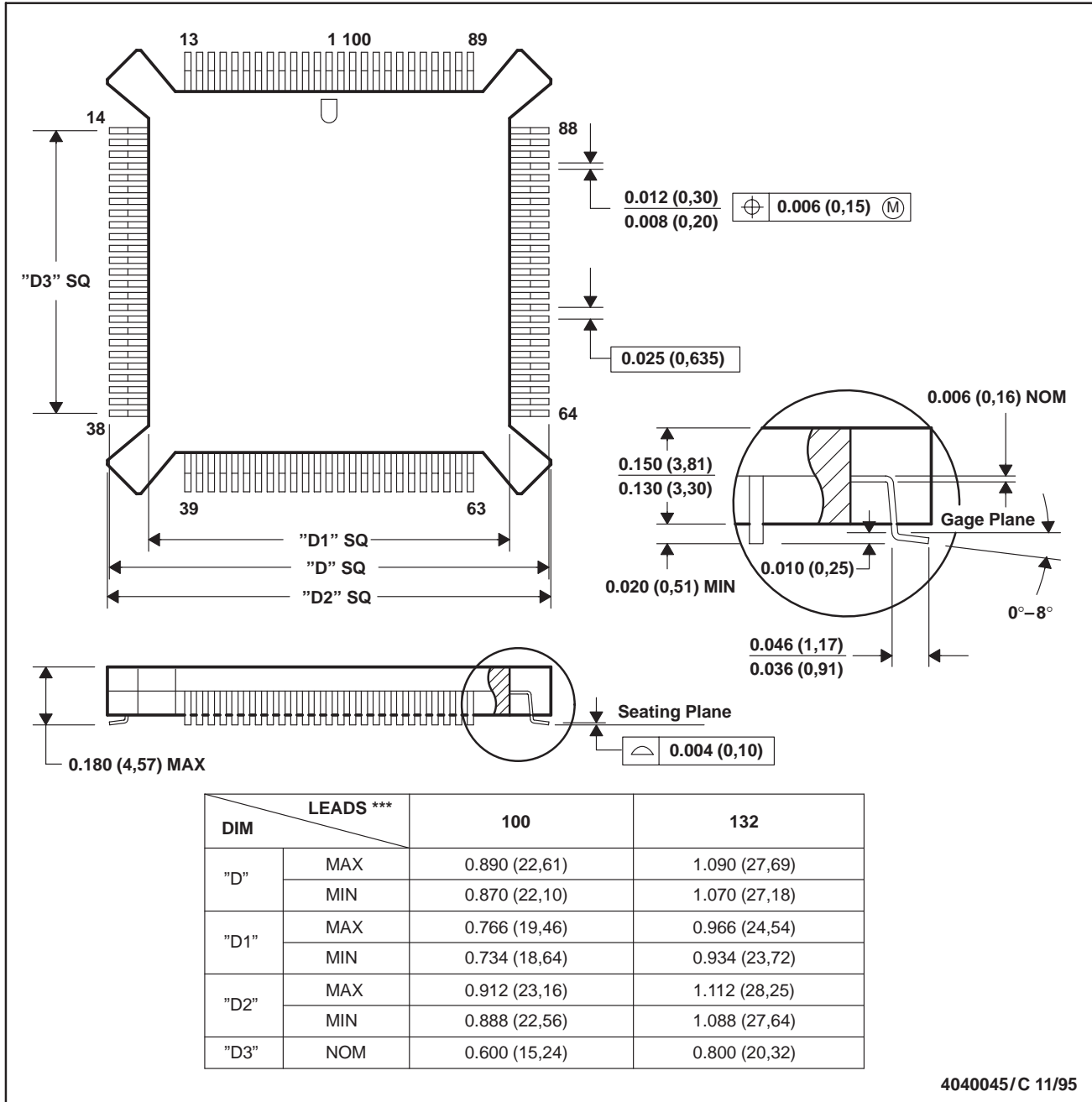

4040045/C 11/95

- NOTES: A. All linear dimensions are in inches (millimeters).  
 B. This drawing is subject to change without notice.  
 C. Falls within JEDEC MO-069



POST OFFICE BOX 1443 • HOUSTON, TEXAS 77251-1443

## **IMPORTANT NOTICE**

Texas Instruments and its subsidiaries (TI) reserve the right to make changes to their products or to discontinue any product or service without notice, and advise customers to obtain the latest version of relevant information to verify, before placing orders, that information being relied on is current and complete. All products are sold subject to the terms and conditions of sale supplied at the time of order acknowledgement, including those pertaining to warranty, patent infringement, and limitation of liability.

TI warrants performance of its semiconductor products to the specifications applicable at the time of sale in accordance with TI's standard warranty. Testing and other quality control techniques are utilized to the extent TI deems necessary to support this warranty. Specific testing of all parameters of each device is not necessarily performed, except those mandated by government requirements.

CERTAIN APPLICATIONS USING SEMICONDUCTOR PRODUCTS MAY INVOLVE POTENTIAL RISKS OF DEATH, PERSONAL INJURY, OR SEVERE PROPERTY OR ENVIRONMENTAL DAMAGE ("CRITICAL APPLICATIONS"). TI SEMICONDUCTOR PRODUCTS ARE NOT DESIGNED, AUTHORIZED, OR WARRANTED TO BE SUITABLE FOR USE IN LIFE-SUPPORT DEVICES OR SYSTEMS OR OTHER CRITICAL APPLICATIONS. INCLUSION OF TI PRODUCTS IN SUCH APPLICATIONS IS UNDERSTOOD TO BE FULLY AT THE CUSTOMER'S RISK.

In order to minimize risks associated with the customer's applications, adequate design and operating safeguards must be provided by the customer to minimize inherent or procedural hazards.

TI assumes no liability for applications assistance or customer product design. TI does not warrant or represent that any license, either express or implied, is granted under any patent right, copyright, mask work right, or other intellectual property right of TI covering or relating to any combination, machine, or process in which such semiconductor products or services might be or are used. TI's publication of information regarding any third party's products or services does not constitute TI's approval, warranty or endorsement thereof.