

SN54ALS1000A, SN74ALS1000A, SN54AS1000A, SN74AS1000A QUADRUPLE 2-INPUT POSITIVE-NAND BUFFERS/DRIVERS

SDAS056A – D2661, APRIL 1984 – REVISED MAY 1986

- 'ALS1000A is a Buffer Version of 'ALS00B
- 'AS1000A is a Driver Version of 'AS00
- 'AS1000A Offers High Capacitive-Driver Capability
- Package Options Include Plastic Small Outline Packages, Ceramic Chip Carriers, and Standard Plastic and Ceramic 300-mil DIPs
- Dependable Texas Instruments Quality and Reliability

SN54ALS1000A, SN54AS1000A ... J PACKAGE
SN74ALS1000A, SN74AS1000A ... D OR N PACKAGE
(TOP VIEW)

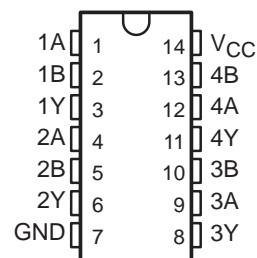

SN54ALS1000A, SN54AS1000A ... FK PACKAGE
(TOP VIEW)

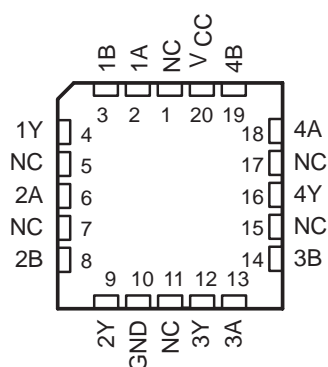

NC – No internal connection

description

These devices contain four independent 2-input NAND buffers/drivers. They perform the Boolean functions $Y = \overline{A \cdot B}$ or $Y = \overline{A} + \overline{B}$ in positive logic.

The SN54ALS1000A and SN54AS1000A are characterized for operation over the full military temperature range of -55°C to 125°C . The SN74ALS1000A and SN74AS1000A are characterized for operation from 0°C to 70°C .

FUNCTION TABLE
(each gate)

INPUTS		OUTPUT
A	B	Y
H	H	L
L	X	H
X	L	H

logic symbol †

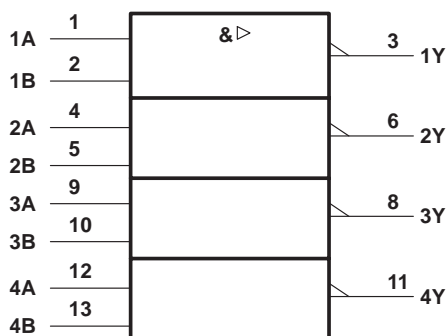

logic diagram (positive logic)

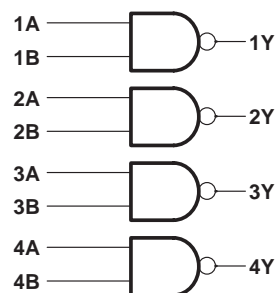

† This symbol is in accordance with ANSI/IEEE Std 91-1984 and IEC Publication 617-12.

Pin numbers shown are for D, J, and N packages.

SN54ALS1000A, SN74ALS1000A QUADRUPLE 2-INPUT POSITIVE-NAND BUFFERS

SDAS056A – D2661, APRIL 1984 – REVISED MAY 1986

absolute maximum ratings over operating free-air temperature range (unless otherwise noted)

Supply voltage, V_{CC}	7 V
Input voltage	7 V
Operating free-air temperature range: SN54ALS1000A	-55°C to 125°C
SN74ALS1000A	0°C to 70°C
Storage temperature range	-65°C to 150°C

recommended operating conditions

		SN54ALS1000A			SN74ALS1000A			UNIT
		MIN	NOM	MAX	MIN	NOM	MAX	
V_{CC}	Supply voltage	4.5	5	5.5	4.5	5	5.5	V
V_{IH}	High-level input voltage	2			2			V
V_{IL}	Low-level input voltage			0.7			0.8	V
I_{OH}	High-level output current			-1			-2.6	mA
I_{OL}	Low-level output current			12			24	mA
T_A	Operating free-air temperature	-55		125	0		70	°C

electrical characteristics over recommended operating-free-air temperature range (unless otherwise noted)

PARAMETER	TEST CONDITIONS	SN54ALS1000A			SN74ALS1000A			UNIT
		MIN	TYP†	MAX	MIN	TYP†	MAX	
V_{IK}	$V_{CC} = 4.5 V$, $I_I = -18 mA$			-1.5			-1.5	V
V_{OH}	$V_{CC} = 4.5 V$ to $5.5 V$, $I_{OH} = -0.4 mA$	$V_{CC}-2$			$V_{CC}-2$			V
	$V_{CC} = 4.5 V$, $I_{OH} = -1 mA$	2.4	3.3					
	$V_{CC} = 4.5 V$, $I_{OH} = -2.6 mA$				2.4	3.3		
V_{OL}	$V_{CC} = 4.5 V$, $I_{OL} = 12 mA$		0.25	0.4		0.25	0.4	V
	$V_{CC} = 4.5 V$, $I_{OL} = 24 mA$					0.35	0.5	
I_I	$V_{CC} = 5.5 V$, $V_I = 7 V$			0.1			0.1	mA
I_{IH}	$V_{CC} = 5.5 V$, $V_I = 2.7 V$			20			20	μA
I_{IL}	$V_{CC} = 5.5 V$, $V_I = 0.4 V$			-0.1			-0.1	mA
I_{O}^{\dagger}	$V_{CC} = 5.5 V$, $V_O = 2.25 V$	-30		-112	-30		-112	mA
I_{CCH}	$V_{CC} = 5.5 V$, $V_I = 0 V$		0.86	1.6		0.86	1.6	mA
I_{CCL}	$V_{CC} = 5.5 V$, $V_I = 4.5 V$		4.8	7.8		4.8	7.8	mA

† All typical values are at $V_{CC} = 5 V$, $T_A = 25^{\circ}C$.

‡ The output conditions have been chosen to produce a current that closely approximates one half of the true short-circuit output current, I_{OS} .

switching characteristics (see Note 1)

PARAMETER	FROM (INPUT)	TO (OUTPUT)	$V_{CC} = 5 V$, $C_L = 50 pF$, $R_L = 500 \Omega$, $T_A = 25^{\circ}C$		$V_{CC} = 4.5 V$ to $5.5 V$, $C_L = 50 pF$, $R_L = 500 \Omega$, $T_A = MIN$ to MAX		UNIT	
			'ALS1000A	SN54ALS1000A	SN74ALS1000A			
			TYP	MIN	MAX	MIN		MAX
t_{PLH}	A or B	Y	4	2	10	2	8	ns
t_{PHL}	A or B	Y	5	2	10	2	7	ns

NOTE 1: Load circuit and voltage waveforms are shown in Section 1.



POST OFFICE BOX 655303 • DALLAS, TEXAS 75265

SN54AS1000A, SN74AS1000A QUADRUPLE 2-INPUT POSITIVE-NAND DRIVERS

SDAS056A – D2661, APRIL 1984 – REVISED MAY 1986

absolute maximum ratings over operating free-air temperature range (unless otherwise noted)

Supply voltage, V_{CC}	7 V
Input voltage	7 V
Operating free-air temperature range: SN54AS1000A	–55°C to 125°C
SN74AS1000A	0°C to 70°C
Storage temperature range	–65°C to 150°C

recommended operating conditions

		SN54AS1000A			SN74AS1000A			UNIT
		MIN	NOM	MAX	MIN	NOM	MAX	
V_{CC}	Supply voltage	4.5	5	5.5	4.5	5	5.5	V
V_{IH}	High-level input voltage	2			2			V
V_{IL}	Low-level input voltage			0.8			0.8	V
I_{OH}	High-level output current			–40			–48	mA
I_{OL}	Low-level output current			40			48	mA
T_A	Operating free-air temperature	–55		125	0		70	°C

electrical characteristics over recommended operating-free-air temperature range (unless otherwise noted)

PARAMETER	TEST CONDITIONS	SN54AS1000A			SN74AS1000A			UNIT
		MIN	TYP†	MAX	MIN	TYP†	MAX	
V_{IK}	$V_{CC} = 4.5\text{ V}$, $I_I = -18\text{ mA}$			–1.2			–1.2	V
V_{OH}	$V_{CC} = 4.5\text{ V to }5.5\text{ V}$, $I_{OH} = -2\text{ mA}$	$V_{CC} - 2$			$V_{CC} - 2$			V
	$V_{CC} = 4.5\text{ V}$, $I_{OH} = -3\text{ mA}$	2.4	3.2		2.4	3.2		
	$V_{CC} = 4.5\text{ V}$, $I_{OH} = -40\text{ mA}$	2						
	$V_{CC} = 4.5\text{ V}$, $I_{OL} = -48\text{ mA}$				2			
V_{OL}	$V_{CC} = 4.5\text{ V}$, $I_{OL} = 40\text{ mA}$		0.25	0.5				V
	$V_{CC} = 4.5\text{ V}$, $I_{OL} = 48\text{ mA}$				0.35	0.5		
I_I	$V_{CC} = 5.5\text{ V}$, $V_I = 7\text{ V}$			0.1			0.1	mA
I_{IH}	$V_{CC} = 5.5\text{ V}$, $V_I = 2.7\text{ V}$			20			20	μA
I_{IL}	$V_{CC} = 5.5\text{ V}$, $V_I = 0.4\text{ V}$			–0.5			–0.5	mA
I_{O}^{\ddagger}	$V_{CC} = 5.5\text{ V}$, $V_O = 2.25\text{ V}$	–30		–200	–30		–200	mA
I_{CCH}	$V_{CC} = 5.5\text{ V}$, $V_I = 0\text{ V}$		2.2	3.5		2.2	3.5	mA
I_{CCL}	$V_{CC} = 5.5\text{ V}$, $V_I = 4.5\text{ V}$		12	19		12	19	mA

† All typical values are at $V_{CC} = 5\text{ V}$, $T_A = 25^\circ\text{C}$.

‡ The output conditions have been chosen to produce a current that closely approximates one half of the true short-circuit output current, I_{OS} .

switching characteristics (see Note 1)

PARAMETER	FROM (INPUT)	TO (OUTPUT)	$V_{CC} = 4.5\text{ V to }5.5\text{ V}$, $C_L = 50\text{ pF}$, $R_L = 500\ \Omega$, $T_A = \text{MIN to MAX}$				UNIT
			SN54AS1000A		SN74AS1000A		
			MIN	MAX	MIN	MAX	
t_{PLH}	A or B	Y	1	5	1	4	ns
t_{PHL}	A or B	Y	1	5	1	4	ns

NOTE 1: Load circuit and voltage waveforms are shown in Section 1.



IMPORTANT NOTICE

Texas Instruments and its subsidiaries (TI) reserve the right to make changes to their products or to discontinue any product or service without notice, and advise customers to obtain the latest version of relevant information to verify, before placing orders, that information being relied on is current and complete. All products are sold subject to the terms and conditions of sale supplied at the time of order acknowledgement, including those pertaining to warranty, patent infringement, and limitation of liability.

TI warrants performance of its semiconductor products to the specifications applicable at the time of sale in accordance with TI's standard warranty. Testing and other quality control techniques are utilized to the extent TI deems necessary to support this warranty. Specific testing of all parameters of each device is not necessarily performed, except those mandated by government requirements.

CERTAIN APPLICATIONS USING SEMICONDUCTOR PRODUCTS MAY INVOLVE POTENTIAL RISKS OF DEATH, PERSONAL INJURY, OR SEVERE PROPERTY OR ENVIRONMENTAL DAMAGE ("CRITICAL APPLICATIONS"). TI SEMICONDUCTOR PRODUCTS ARE NOT DESIGNED, AUTHORIZED, OR WARRANTED TO BE SUITABLE FOR USE IN LIFE-SUPPORT DEVICES OR SYSTEMS OR OTHER CRITICAL APPLICATIONS. INCLUSION OF TI PRODUCTS IN SUCH APPLICATIONS IS UNDERSTOOD TO BE FULLY AT THE CUSTOMER'S RISK.

In order to minimize risks associated with the customer's applications, adequate design and operating safeguards must be provided by the customer to minimize inherent or procedural hazards.

TI assumes no liability for applications assistance or customer product design. TI does not warrant or represent that any license, either express or implied, is granted under any patent right, copyright, mask work right, or other intellectual property right of TI covering or relating to any combination, machine, or process in which such semiconductor products or services might be or are used. TI's publication of information regarding any third party's products or services does not constitute TI's approval, warranty or endorsement thereof.