

SN54S134, SN74S134 12-INPUT POSITIVE-NAND GATES WITH 3-STATE OUTPUTS

SDLS203

DECEMBER 1983 - REVISED MARCH 1988

- Package Options Include Plastic "Small Outline" Packages, Ceramic Chip Carriers and Flat Packages, and Plastic and Ceramic DIPs
- Dependable Texas Instruments Quality and Reliability

description

The 'S134 feature three-state outputs that, when enabled, have the low impedance characteristics of a TTL output with additional drive capability at high logic levels to permit driving heavily loaded lines without external pull-up resistors. When disabled, both output transistors are turned off presenting a high-impedance state to the bus so the output will act neither as a significant load nor as a driver. The 'S134 outputs are disabled when G is high.

logic diagram

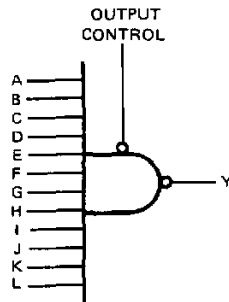

positive logic

$$Y = A \cdot B \cdot C \cdot D \cdot E \cdot F \cdot G \cdot H \cdot I \cdot J \cdot K \cdot L \text{ or } Y = \overline{A + B + C + D + E + F + G + H + I + J + K + L}$$

Output is off (disabled) when output control is high.

SN54S134 . . . J OR W PACKAGE
SN74S134 . . . D OR N PACKAGE
(TOP VIEW)

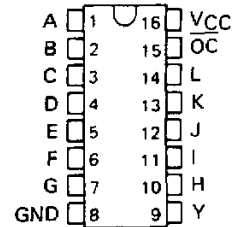

SN54S134 . . . FK PACKAGE
(TOP VIEW)

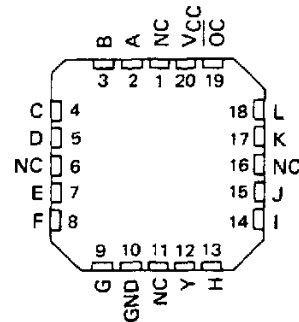

NC - No internal connection

logic symbol†

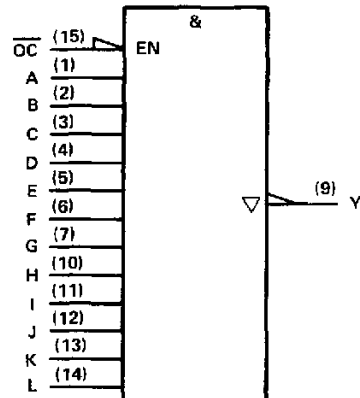

†This symbol is in accordance with ANSI/IEEE Std 91-1984 and IEC Publication 617-12.

Pin numbers shown are for D, J, N, and W packages.

PRODUCTION DATA documents contain information current as of publication date. Products conform to specifications per the terms of Texas Instruments standard warranty. Production processing does not necessarily include testing of all parameters.

TEXAS
INSTRUMENTS

POST OFFICE BOX 655012 • DALLAS, TEXAS 75265

SN54S134, SN74S134
12-INPUT POSITIVE-NAND GATES WITH 3-STATE OUTPUTS

schematic

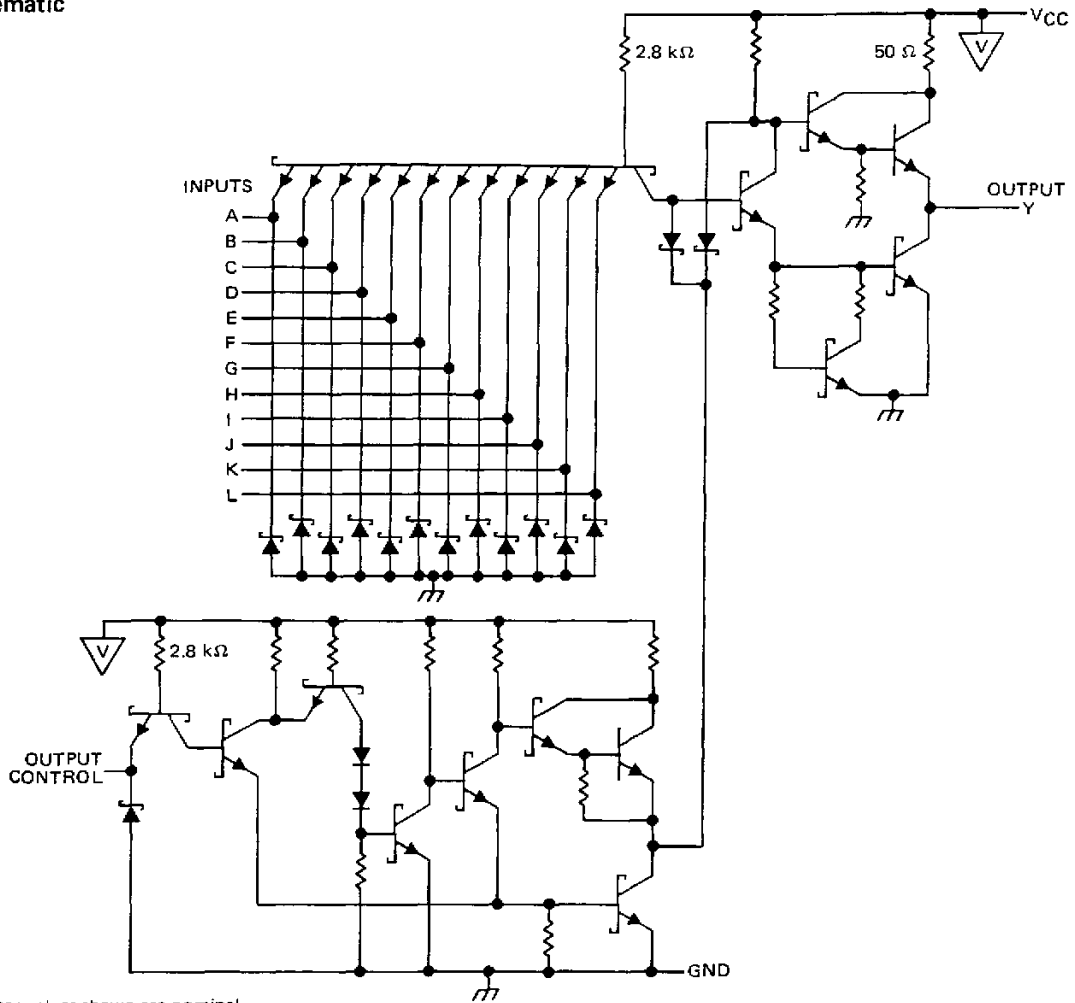

Resistor values shown are nominal.

absolute maximum ratings over operating free-air temperature range (unless otherwise noted)

Supply voltage, VCC (see Note 1).....	7 V
Input voltage	5.5 V
Voltage applied to a disabled 3-state output.....	5.5 V
Operating free-air temperature range: SN54'	-55°C to 125°C
SN74'	0°C to 70°C
Storage temperature range	-65°C to 150°C

NOTE 1: Voltage values are with respect to network ground terminal.

TEXAS
INSTRUMENTS

POST OFFICE BOX 655012 • DALLAS, TEXAS 75265

SN54S134, SN74S134

12-INPUT POSITIVE-NAND GATES WITH 3-STATE OUTPUTS

recommended operating conditions

	SN54S134			SN74S134			UNIT
	MIN	NOM	MAX	MIN	NOM	MAX	
V _{CC} Supply voltage	4.5	5	5.5	4.75	5	5.25	V
V _{IH} High-level input voltage	2			2			V
V _{IL} Low-level input voltage	0.8			0.8			V
I _{OH} High-level output current	-2			-6.5			mA
I _{OL} Low-level output current	20			20			mA
T _A Operating free-air temperature	-55	125		0	70		°C

electrical characteristics over recommended operating free-air temperature range (unless otherwise noted)

PARAMETER	TEST CONDITIONS†	SN54S134			SN74S134			UNIT
		MIN	TYP‡	MAX	MIN	TYP‡	MAX	
V _{IK}	V _{CC} = MIN, I _I = -18 mA	-1.2			-1.2			V
V _{OH}	V _{CC} = MIN, V _{IH} = 2 V, I _{OH} = -2 mA	2.4	3.4					V
	V _{CC} = MIN, V _{IH} = 2 V, I _{OH} = -6.5 mA				2.4	3.2		V
V _{OL}	V _{CC} = MIN, V _{IH} = 2 V, V _{IL} = 0.8 V, I _{OL} = 20 mA	0.5			0.5			V
I _{OZ}	V _{CC} = MAX, V _{IH} = 2 V, V _{IL} = 0.8 V	50			50			μA
		-50			-50			μA
I _I	V _{CC} = MAX, V _I = 5.5 V	1			1			mA
I _{IH}	V _{CC} = MAX, V _I = 2.7 V	50			50			μA
I _{IL}	V _{CC} = MAX, V _I = 0.9 V	-2			-2			mA
I _{OS} §	V _{CC} = MAX	-40	-100		-40	-100		mA
I _{CC}	V _{CC} = MAX	Outputs high		7	13	7	13	mA
		Outputs low		9	16	9	16	
		Outputs disabled		14	25	14	25	

† For conditions shown as MIN or MAX, use the appropriate value specified under recommended operating conditions.

‡ All typical values are at V_{CC} = 5 V, T_A = 25°C.

§ Not more than one output should be shorted at a time, and duration of the short circuit should not exceed one second.

switching characteristics, V_{CC} = 5 V, T_A = 25°C (see note 2)

PARAMETER	TEST CONDITIONS	SN54S134			SN74S134			UNIT
		MIN	TYP	MAX	MIN	TYP	MAX	
t _{PLH}	R _L = 280 Ω, C _L = 15 pF	4	6		4	6		ns
t _{PLH}	R _L = 280 Ω, C _L = 50 pF	5.5			5.5			ns
t _{PHL}	R _L = 280 Ω, C _L = 15 pF	5	7.5		5	7.5		ns
t _{PHL}	R _L = 280 Ω, C _L = 50 pF	7			7			ns
t _{PZH}	R _L = 280 Ω, C _L = 50 pF	13	19.5		13	19.5		ns
t _{PZL}		14	21		14	21		ns
t _{PHZ}	R _L = 280 Ω, C _L = 5 pF	5.5	8.5		5.5	8.5		ns
t _{PLZ}		9	14		9	14		ns

NOTE 2: Load circuits and voltage waveforms are shown in Section 1.

TEXAS
INSTRUMENTS

POST OFFICE BOX 655012 • DALLAS, TEXAS 75265

IMPORTANT NOTICE

Texas Instruments and its subsidiaries (TI) reserve the right to make changes to their products or to discontinue any product or service without notice, and advise customers to obtain the latest version of relevant information to verify, before placing orders, that information being relied on is current and complete. All products are sold subject to the terms and conditions of sale supplied at the time of order acknowledgement, including those pertaining to warranty, patent infringement, and limitation of liability.

TI warrants performance of its semiconductor products to the specifications applicable at the time of sale in accordance with TI's standard warranty. Testing and other quality control techniques are utilized to the extent TI deems necessary to support this warranty. Specific testing of all parameters of each device is not necessarily performed, except those mandated by government requirements.

CERTAIN APPLICATIONS USING SEMICONDUCTOR PRODUCTS MAY INVOLVE POTENTIAL RISKS OF DEATH, PERSONAL INJURY, OR SEVERE PROPERTY OR ENVIRONMENTAL DAMAGE ("CRITICAL APPLICATIONS"). TI SEMICONDUCTOR PRODUCTS ARE NOT DESIGNED, AUTHORIZED, OR WARRANTED TO BE SUITABLE FOR USE IN LIFE-SUPPORT DEVICES OR SYSTEMS OR OTHER CRITICAL APPLICATIONS. INCLUSION OF TI PRODUCTS IN SUCH APPLICATIONS IS UNDERSTOOD TO BE FULLY AT THE CUSTOMER'S RISK.

In order to minimize risks associated with the customer's applications, adequate design and operating safeguards must be provided by the customer to minimize inherent or procedural hazards.

TI assumes no liability for applications assistance or customer product design. TI does not warrant or represent that any license, either express or implied, is granted under any patent right, copyright, mask work right, or other intellectual property right of TI covering or relating to any combination, machine, or process in which such semiconductor products or services might be or are used. TI's publication of information regarding any third party's products or services does not constitute TI's approval, warranty or endorsement thereof.