

SN5423, SN5425, SN7423, SN7425 DUAL 4-INPUT NOR GATES WITH STROBE

SDLS082

DECEMBER 1983—REVISED MARCH 1988

- Package Options Include Plastic and Ceramic DIPs and Ceramic Flat Packages
- Dependable Texas Instruments Quality and Reliability

description

These devices contain dual 4-input positive NOR gates with strobe. They perform the Boolean function:

$$Y = \overline{G(A+B+C+D)}$$

(with 1X and 1X̄ of '23 left open).

The SN5423 and the SN5425 are characterized for operation over the full military temperature range of -55°C to 125°C. The SN7423 and the SN7425 are characterized for operation from 0°C to 70°C.

FUNCTION TABLE

INPUTS					OUTPUT
A	B	C	D	G	Y
H	X	X	X	H	L
X	H	X	X	H	L
X	X	H	X	H	L
X	X	X	H	H	L
L	L	L	L	X	H
X	X	X	X	L	H

Expander inputs are open.
H = high level, L = low level, X = irrelevant

logic symbols†

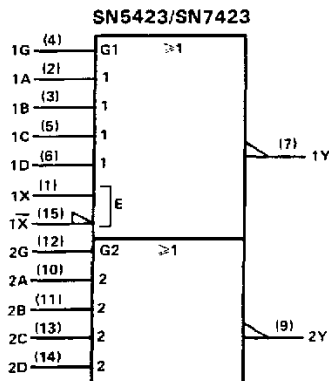

SN5423 . . . J OR W PACKAGE
SN7423 . . . N PACKAGE
(TOP VIEW)

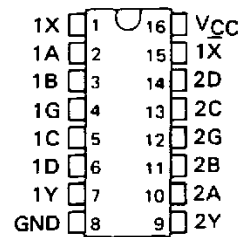

SN5425 . . . J OR W PACKAGE
SN7425 . . . N PACKAGE
(TOP VIEW)

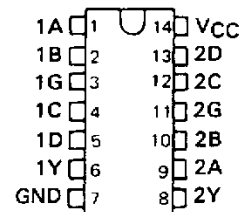

logic diagram

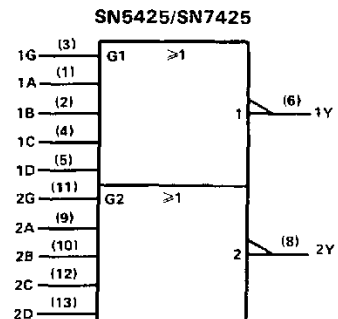
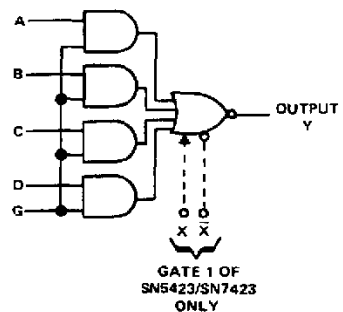

†These symbols are in accordance with ANSI/IEEE Std. 91-1984 and IEC Publication 617-12. Pin numbers are for J, N, or W packages.

PRODUCTION DATA documents contain information current as of publication date. Products conform to specifications per the terms of Texas Instruments standard warranty. Production processing does not necessarily include testing of all parameters.

TEXAS
INSTRUMENTS

POST OFFICE BOX 655012 • DALLAS, TEXAS 75265

SN5423, SN5425, SN7423, SNSN7425 DUAL 4-INPUT NOR GATES WITH STROBE

schematic (each gate)

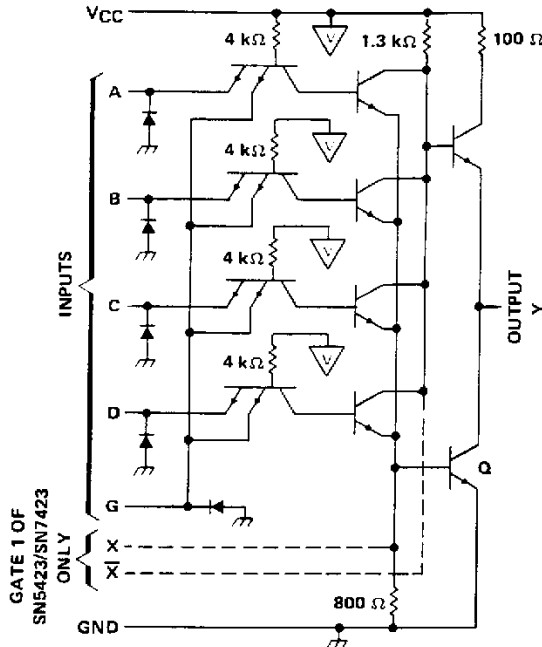

- NOTES: A. Component values shown are nominal.
 B. Both expander inputs are used simultaneously for expanding.
 C. If expander is not used leave X and X open.
 D. A total of four expander gates can be connected to the expander inputs.

 - VCC bus

absolute maximum ratings over operating free-air temperature range (unless otherwise noted)

Supply voltage V_{CC} (see Note 1)	7 V
Input voltage (see Note 1)	5.5 V
Intermitter voltage (see Note 2)	5.5 V
Operating free-air temperature range: SN5423, SN5425 Circuits	-55°C to 125°C
SN7423, SN7425 Circuits	0°C to 70°C
Storage temperature range	-65°C to 150°C

- NOTES: 1. Voltage values, except intermitter voltage, are with respect to network ground terminal.
 2. This is the voltage between two emitters of a multiple-emitter transistor.

recommended operating conditions

		'23, '25			UNIT
		MIN	NOM	MAX	
V_{CC} Supply voltage	54 Family	4.5	5	5.5	V
	74 Family	4.75	5	5.25	
V_{IH} High-level input voltage		2			V
V_{IL} Low-level input voltage		0.8			V
I_{OH} High-level output current		-0.8			mA
I_{OL} Low-level output current	54 Family	16			mA
	74 Family	16			
T_A Operating free-air temperature range	54 Family	-55	125		°C
	74 Family	0	70		

The '23 is designed for use with up to four '60 expanders.

TEXAS
INSTRUMENTS

POST OFFICE BOX 655012 • DALLAS, TEXAS 75265

SN5423, SN5425, SN7423, SN7425 DUAL 4-INPUT NOR GATES WITH STROBE

electrical characteristics over recommended operating free-air temperature range (unless otherwise noted)

PARAMETER	TEST CONDITIONS†	MIN	TYP‡	MAX	UNIT	
V_I	$V_{CC} = \text{MIN}, I_I = -12 \text{ mA}$			-1.5	V	
V_{OH}	$V_{CC} = \text{MIN}, V_{IL} = 0.8 \text{ V}, I_{OH} = -0.8 \text{ mA}$	2.4	3.4		V	
V_{OL}	$V_{CC} = \text{MIN}, V_{IH} = 2 \text{ V}, I_{OL} = 16 \text{ mA}$		0.2	0.4	V	
I_I	$V_{CC} = \text{MAX}, V_I = 5.5 \text{ V}$			1	mA	
I_{IH}	data inputs	$V_{CC} = \text{MAX}, V_I = 2.4 \text{ V}$			μA	
	strobe inputs					
I_{IL}	data inputs	$V_{CC} = \text{MAX}, V_I = 0.4 \text{ V}$			mA	
	strobe inputs					
$I_{OS}\S$	$V_{CC} = \text{MAX}$		54 Family	-20	-55	mA
			74 Family	-18	-55	
I_{CCH}	$V_{CC} = \text{MAX},$ All inputs at 0 V		8	16	mA	
I_{CCL}	$V_{CC} = \text{MAX},$ All inputs at 5 V		10	19	mA	

† For conditions shown as MIN or MAX, use the appropriate value specified under recommended operating conditions for the applicable device type. Expander inputs X and \bar{X} are open.

‡ All typical values are at $V_{CC} = 5 \text{ V}, T_A = 25^\circ\text{C}$.

§ Not more than one output should be shorted at a time.

electrical characteristics (SN5423 circuits) using expander inputs, $V_{CC} = 4.5 \text{ V}, T_A = -55^\circ\text{C}$

PARAMETER	TEST CONDITIONS	MIN	TYP†	MAX	UNIT
$I_{\bar{X}}$ Expander current	$V_{X\bar{X}} = 0.4 \text{ V}, I_{OL} = 16 \text{ mA}$			-3.5	mA
$V_{BE(Q)}$ Base-Emitter voltage of output transistor (Q)	$I_{OL} = 16 \text{ mA}, I_X + I_{\bar{X}} = 0.41 \text{ mA}, R_{X\bar{X}} = 0$			1.1	V
V_{OH} High-level output voltage	$I_{OH} = -0.4 \text{ mA}, I_X = 0.15 \text{ mA}, I_{\bar{X}} = -0.15 \text{ mA}$	2.4	3.4		V
V_{OL} Low-level output voltage	$I_{OL} = 16 \text{ mA}, I_X + I_{\bar{X}} = 0.3 \text{ mA}, R_{X\bar{X}} = 114 \Omega$		0.2	0.4	V

electrical characteristics (SN7423 circuits) using expander inputs, $V_{CC} = 4.75 \text{ V}, T_A = 0^\circ\text{C}$

PARAMETER	TEST CONDITIONS	MIN	TYP†	MAX	UNIT
$I_{\bar{X}}$ Expander current	$V_{X\bar{X}} = 0.4 \text{ V}, I_{OL} = 16 \text{ mA}$			-3.8	mA
$V_{BE(Q)}$ Base-Emitter voltage of output transistor (Q)	$I_{OL} = 16 \text{ mA}, I_X + I_{\bar{X}} = 0.62 \text{ mA}, R_{X\bar{X}} = 0$			1	V
V_{OH} High-level output voltage	$I_{OH} = -0.4 \text{ mA}, I_X = 0.27 \text{ mA}, I_{\bar{X}} = -0.27 \text{ mA}$	2.4	3.4		V
V_{OL} Low-level output voltage	$I_{OL} = 16 \text{ mA}, I_X + I_{\bar{X}} = 0.43 \text{ mA}, R_{X\bar{X}} = 130 \Omega$		0.2	0.4	V

† All typical values are at $V_{CC} = 5 \text{ V}, T_A = 25^\circ\text{C}$.

switching characteristics, $V_{CC} = 5 \text{ V}, T_A = 25^\circ\text{C}, N = 10,$ (see note 3)

PARAMETER	TEST CONDITIONS	MIN	TYP	MAX	UNIT
t_{PLH}	$R_L = 400 \Omega, C_L = 15 \text{ pF}$		13	22	ns
t_{PHL}	$R_L = 400 \Omega, C_L = 15 \text{ pF}$		8	15	ns

NOTE 3: Switching characteristics of the SN5423 and SN7424 are tested with the expander pins open.

TEXAS
INSTRUMENTS

POST OFFICE BOX 655012 • DALLAS, TEXAS 75265

IMPORTANT NOTICE

Texas Instruments and its subsidiaries (TI) reserve the right to make changes to their products or to discontinue any product or service without notice, and advise customers to obtain the latest version of relevant information to verify, before placing orders, that information being relied on is current and complete. All products are sold subject to the terms and conditions of sale supplied at the time of order acknowledgement, including those pertaining to warranty, patent infringement, and limitation of liability.

TI warrants performance of its semiconductor products to the specifications applicable at the time of sale in accordance with TI's standard warranty. Testing and other quality control techniques are utilized to the extent TI deems necessary to support this warranty. Specific testing of all parameters of each device is not necessarily performed, except those mandated by government requirements.

CERTAIN APPLICATIONS USING SEMICONDUCTOR PRODUCTS MAY INVOLVE POTENTIAL RISKS OF DEATH, PERSONAL INJURY, OR SEVERE PROPERTY OR ENVIRONMENTAL DAMAGE ("CRITICAL APPLICATIONS"). TI SEMICONDUCTOR PRODUCTS ARE NOT DESIGNED, AUTHORIZED, OR WARRANTED TO BE SUITABLE FOR USE IN LIFE-SUPPORT DEVICES OR SYSTEMS OR OTHER CRITICAL APPLICATIONS. INCLUSION OF TI PRODUCTS IN SUCH APPLICATIONS IS UNDERSTOOD TO BE FULLY AT THE CUSTOMER'S RISK.

In order to minimize risks associated with the customer's applications, adequate design and operating safeguards must be provided by the customer to minimize inherent or procedural hazards.

TI assumes no liability for applications assistance or customer product design. TI does not warrant or represent that any license, either express or implied, is granted under any patent right, copyright, mask work right, or other intellectual property right of TI covering or relating to any combination, machine, or process in which such semiconductor products or services might be or are used. TI's publication of information regarding any third party's products or services does not constitute TI's approval, warranty or endorsement thereof.