

SN54ALS563A, SN74ALS563B

OCTAL D-TYPE TRANSPARENT LATCHES WITH 3-STATE OUTPUTS

SDAS163 – D2661, DECEMBER 1982 – REVISED JANUARY 1989

- **3-State Buffer-Type Outputs Drive Bus-Lines Directly**
- **Bus Structured Pinout**
- **Package Options include Plastic Small Outline Package, Ceramic Chip Carriers and Standard Plastic and Ceramic DIPs**
- **Dependable Texas Instruments Quality and Reliability**

description

These 8-bit latches feature three-state outputs designed specifically for driving highly capacitive or relatively low-impedance loads. They are particularly suitable for implementing buffer registers, I/O ports, bidirectional bus drivers, and working registers.

The eight latches are transparent D-type latches. While the enable (C) is high the Q outputs will follow the complements of data (D) inputs. When the enable is taken low the output will be latched at the inverses of the levels that were set up at the D inputs.

A buffered output-control input can be used to place the eight outputs in either a normal logic state (high or low logic levels) or a high-impedance state. In the high-impedance state the outputs neither load nor drive the bus lines significantly. The high-impedance state and increased high-logic level provide the capability to drive the bus lines in a bus-organized system without need for interface or pull-up components.

The output control (OC) does not affect the internal operation of the latches. Old data can be retained or new data can be entered while the outputs are in the high-impedance state.

The SN54ALS563A is characterized for operation over the full military temperature range of -55°C to 125°C . The SN74ALS563B is characterized for operation from 0°C to 70°C .

SN54ALS563A . . . J PACKAGE
SN74ALS563B . . . DW OR N PACKAGE
(TOP VIEW)

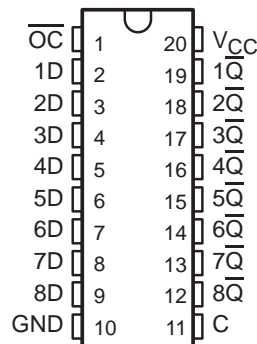

SN54ALS563A . . . FK PACKAGE
(TOP VIEW)

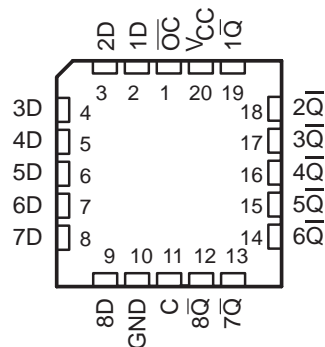

FUNCTION TABLE
(each latch)

INPUTS			OUTPUT Q
ENABLE OC	C	D	
L	H	H	L
L	H	H	H
L	L	X	Q ₀
H	X	X	Z

PRODUCTION DATA information is current as of publication date. Products conform to specifications per the terms of Texas Instruments standard warranty. Production processing does not necessarily include testing of all parameters.



SN54ALS563A, SN74ALS563B OCTAL D-TYPE TRANSPARENT LATCHES WITH 3-STATE OUTPUTS

SDAS163 – D2661, DECEMBER 1982 – REVISED JANUARY 1989

logic symbol†

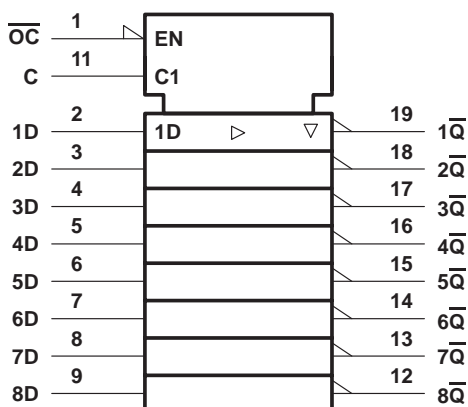

† This symbol is in accordance with ANSI/IEEE Std 91-1984 and IEC Publication 617-12. Pin numbers shown are for DW, J, and N packages.

logic diagram (positive logic)

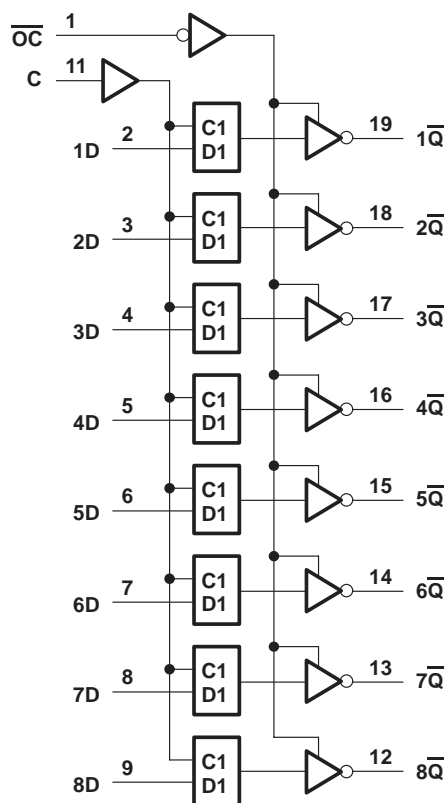

absolute maximum ratings over operating free-air temperature range (unless otherwise noted)

Supply voltage, V_{CC}	7 V
Input voltage	7 V
Voltage applied to a disabled 3-state output	5.5 V
Operating free-air temperature range: SN54ALS563A	-55°C to 125°C
SN74ALS563B	0°C to 70°C
Storage temperature range	-65°C to 150°C

recommended operating conditions

	SN54ALS563A			SN74ALS563B			UNIT
	MIN	NOM	MAX	MIN	NOM	MAX	
V_{CC} Supply Voltage	4.5	5	5.5	4.5	5	5.5	V
V_{IH} High-level input voltage	2			2			V
V_{IL} Low-level input voltage			0.7			0.8	V
I_{OH} High-level output current			-1			-2.6	mA
I_{OL} Low-level output current			12			24	mA
t_w Pulse duration, C high	15			15			ns
t_{su} Setup time, data before C↓	10			10			ns
t_h Hold time, data after C↓	10			10			ns
T_A Operating free-air temperature	-55		125	0		70	°C



POST OFFICE BOX 655303 • DALLAS, TEXAS 75265

SN54ALS563A, SN74ALS563B OCTAL D-TYPE TRANSPARENT LATCHES WITH 3-STATE OUTPUTS

SDAS163 – D2661, DECEMBER 1982 – REVISED JANUARY 1989

electrical characteristics over recommended operating free-air temperature range (unless otherwise noted)

PARAMETER	TEST CONDITIONS		SN54ALS563A			SN74ALS563B			UNIT
			MIN	TYP†	MAX	MIN	TYP†	MAX	
V_{IK}	$V_{CC} = 4.5\text{ V}$,	$I_I = -18\text{ mA}$			-1.2			-1.2	V
V_{OH}	$V_{CC} = 4.5\text{ V to }5.5\text{ V}$,	$I_{OH} = -0.4\text{ mA}$	$V_{CC}-2$			$V_{CC}-2$			V
	$V_{CC} = 4.5\text{ V}$,	$I_{OL} = -1\text{ mA}$	2.4	3.3					
	$V_{CC} = 4.5\text{ V}$,	$I_{OH} = -2.6\text{ mA}$				2.4	3.2		
V_{OL}	$V_{CC} = 4.5\text{ V}$,	$I_{OL} = 12\text{ mA}$		0.25	0.4		0.25	0.4	V
	$V_{CC} = 4.5\text{ V}$,	$I_{OL} = 24\text{ mA}$					0.35	0.5	
I_{OZH}	$V_{CC} = 5.5\text{ V}$,	$V_O = 2.7\text{ V}$			20			20	μA
I_{OZL}	$V_{CC} = 5.5\text{ V}$,	$V_O = 0.4\text{ V}$			-20			-20	μA
I_I	$V_{CC} = 5.5\text{ V}$,	$V_I = 7\text{ V}$			0.1			0.1	mA
I_{IH}	$V_{CC} = 5.5\text{ V}$,	$V_I = 2.7\text{ V}$			20			20	μA
I_{IL}	$V_{CC} = 5.5\text{ V}$,	$V_I = 0.4\text{ V}$			-0.1			-0.1	mA
$I_{O\ddagger}$	$V_{CC} = 5.5\text{ V}$,	$V_O = 2.25\text{ V}$	-30		-112	-30		-112	mA
I_{CC}	$V_{CC} = 5.5\text{ V}$	Outputs high		10	17		10	17	mA
		Outputs low		16	26		16	26	
		Outputs disabled		17	29		17	29	

† All typical Values are at $V_{CC} = 5\text{ V}$, $T_A = 25^\circ\text{C}$.

‡ The output conditions have been chosen to produce a current that closely approximates one half of the true short-circuit output current, I_{OS} .

switching characteristics (see Note 1)

PARAMETER	FROM (INPUT)	TO (OUTPUT)	$V_{CC} = 5\text{ V}$, $C_L = 50\text{ pF}$, $R_1 = 500\ \Omega$, $R_2 = 500\ \Omega$, $T_A = 25^\circ\text{C}$		$V_{CC} = 4.5\text{ V to }5.5\text{ V}$, $C_L = 50\text{ pF}$, $R_1 = 500\ \Omega$, $R_2 = 500\ \Omega$, $T_A = \text{MIN to MAX}\S$				UNIT
			'ALS563	SN54ALS563A	SN74ALS563B				
			TYP	MIN	MAX	MIN	MAX		
t_{PLH}	D	Q	10	3	21	3	18	ns	
t_{PHL}			8	3	15	3	14		
t_{PLH}	C	Q	8	8	29	6	22	ns	
t_{PHL}			14	8	22	6	21		
t_{PZH}	OC	Q	8	4	21	3	18	ns	
t_{PZL}			10	4	21	4	18		
t_{PHZ}	OC	Q	5	2	12	1	10	ns	
t_{PLZ}			7	3	18	1	15		

§ For conditions shown MIN or MAX, use the appropriate value specified under recommended operating conditions.

NOTE 1: Load circuit and voltage waveforms are shown in Section 1 of the *ALS/AS Logic Data Book*, 1986.



IMPORTANT NOTICE

Texas Instruments and its subsidiaries (TI) reserve the right to make changes to their products or to discontinue any product or service without notice, and advise customers to obtain the latest version of relevant information to verify, before placing orders, that information being relied on is current and complete. All products are sold subject to the terms and conditions of sale supplied at the time of order acknowledgement, including those pertaining to warranty, patent infringement, and limitation of liability.

TI warrants performance of its semiconductor products to the specifications applicable at the time of sale in accordance with TI's standard warranty. Testing and other quality control techniques are utilized to the extent TI deems necessary to support this warranty. Specific testing of all parameters of each device is not necessarily performed, except those mandated by government requirements.

CERTAIN APPLICATIONS USING SEMICONDUCTOR PRODUCTS MAY INVOLVE POTENTIAL RISKS OF DEATH, PERSONAL INJURY, OR SEVERE PROPERTY OR ENVIRONMENTAL DAMAGE ("CRITICAL APPLICATIONS"). TI SEMICONDUCTOR PRODUCTS ARE NOT DESIGNED, AUTHORIZED, OR WARRANTED TO BE SUITABLE FOR USE IN LIFE-SUPPORT DEVICES OR SYSTEMS OR OTHER CRITICAL APPLICATIONS. INCLUSION OF TI PRODUCTS IN SUCH APPLICATIONS IS UNDERSTOOD TO BE FULLY AT THE CUSTOMER'S RISK.

In order to minimize risks associated with the customer's applications, adequate design and operating safeguards must be provided by the customer to minimize inherent or procedural hazards.

TI assumes no liability for applications assistance or customer product design. TI does not warrant or represent that any license, either express or implied, is granted under any patent right, copyright, mask work right, or other intellectual property right of TI covering or relating to any combination, machine, or process in which such semiconductor products or services might be or are used. TI's publication of information regarding any third party's products or services does not constitute TI's approval, warranty or endorsement thereof.