

# TIBPAL20L8-7C, TIBPAL20R4-7C, TIBPAL20R6-7C, TIBPAL20R8-7C TIBPAL20L8-10M, TIBPAL20R4-10M, TIBPAL20R6-10M, TIBPAL20R8-10M HIGH-PERFORMANCE *IMPACT-X*<sup>TM</sup> PAL<sup>®</sup> CIRCUITS

SRPS005D – D3307, OCTOBER 1989 – REVISED NOVEMBER 1995

- **High-Performance Operation:**
  - $f_{max}$  (no feedback)
    - TIBPAL20R' -7C Series . . . 100 MHz
    - TIBPAL20R' -10M Series . . . 62.5 MHz
  - $f_{max}$  (internal feedback)
    - TIBPAL20R' -7C Series . . . 100 MHz
    - TIBPAL20R' -10M Series . . . 62.5 MHz
  - $f_{max}$  (external feedback)
    - TIBPAL20R' -7C Series . . . 74 MHz
    - TIBPAL20R' -10M Series . . . 50 MHz
  - Propagation Delay
    - TIBPAL20L8-7C Series . . . 7 ns Max
    - TIBPAL20L8-10M Series . . . 10 ns Max

- **Functionally Equivalent, but Faster Than Existing 24-Pin PLD Circuits**
- **Preload Capability on Output Registers Simplifies Testing**
- **Power-Up Clear on Registered Devices (All Register Outputs are Set Low, but Voltage Levels at the Output Pins Go High)**
- **Package Options Include Both Plastic and Ceramic Chip Carriers in Addition to Plastic and Ceramic DIPs**
- **Security Fuse Prevents Duplication**
- **Dependable Texas Instruments Quality and Reliability**

DEVICE	I INPUTS	3-STATE O OUTPUTS	REGISTERED Q OUTPUTS	I/O PORTS
PAL20L8	14	2	0	6
PAL20R4	12	0	4 (3-state buffers)	4
PAL20R6	12	0	6 (3-state buffers)	2
PAL20R8	12	0	8 (3-state buffers)	0

## description

These programmable array logic devices feature high speed and functional equivalency when compared with currently available devices. These *IMPACT-X*<sup>TM</sup> circuits combine the latest Advanced Low-Power Schottky technology with proven titanium-tungsten fuses to provide reliable, high-performance substitutes for conventional TTL logic. Their easy programmability allows for quick design of custom functions and typically results in a more compact circuit board. In addition, chip carriers are available for further reduction in board space.

All of the register outputs are set to a low level during power-up. Extra circuitry has been provided to allow loading of each register asynchronously to either a high or low state. This feature simplifies testing because the registers can be set to an initial state prior to executing the test sequence.

The TIBPAL20' C series is characterized from 0°C to 75°C. The TIBPAL20' M series is characterized for operation over the full military temperature range of -55°C to 125°C.

These devices are covered by U.S. Patent 4,410,987.  
*IMPACT-X* is a trademark of Texas Instruments Incorporated.  
 PAL is a registered trademark of Advanced Micro Devices Inc.

**TIBPAL20L8'**  
C SUFFIX . . . JT OR NT PACKAGE  
M SUFFIX . . . JT PACKAGE  
(TOP VIEW)

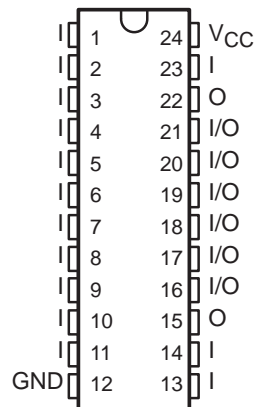

**TIBPAL20L8'**  
C SUFFIX . . . FN PACKAGE  
M SUFFIX . . . FK PACKAGE  
(TOP VIEW)

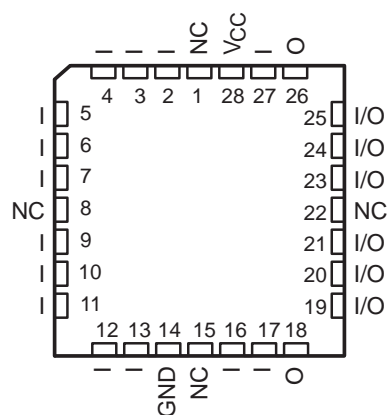

NC — No internal connection  
 Pin assignments in operating mode

PRODUCTION DATA information is current as of publication date. Products conform to specifications per the terms of Texas Instruments standard warranty. Production processing does not necessarily include testing of all parameters.



**TIBPAL20R4-7C, TIBPAL20R6-7C, TIBPAL20R8-7C**  
**TIBPAL20R4-10M, TIBPAL20R6-10M, TIBPAL20R8-10M**  
**HIGH-PERFORMANCE *IMPACT-X*™ PAL® CIRCUITS**

SRPS005D – D3307, OCTOBER 1989 – REVISED NOVEMBER 1995

**TIBPAL20R4'**  
**C SUFFIX ... JT OR NT PACKAGE**  
**M SUFFIX ... JT PACKAGE**

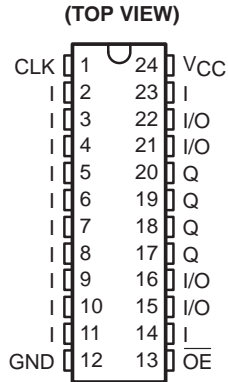

**TIBPAL20R4'**  
**C SUFFIX ... FN PACKAGE**  
**M SUFFIX ... FK PACKAGE**

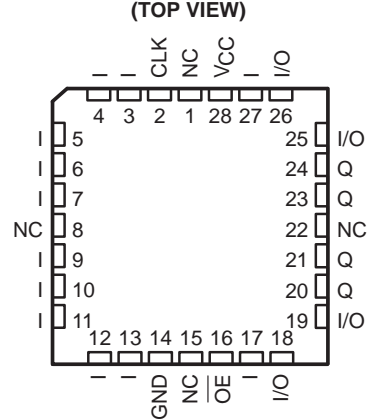

**TIBPAL20R6'**  
**C SUFFIX ... JT OR NT PACKAGE**  
**M SUFFIX ... JT PACKAGE**

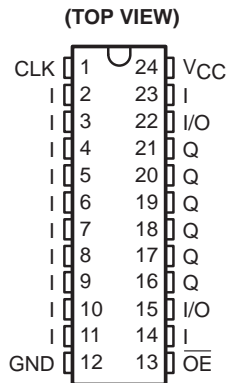

**TIBPAL20R6'**  
**C SUFFIX ... FN PACKAGE**  
**M SUFFIX ... FK PACKAGE**

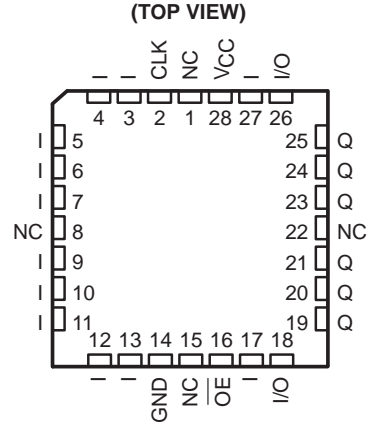

**TIBPAL20R8'**  
**C SUFFIX ... JT OR NT PACKAGE**  
**M SUFFIX ... JT PACKAGE**

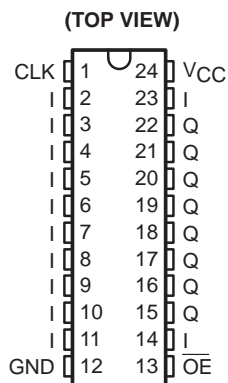

**TIBPAL20R8'**  
**C SUFFIX ... FN PACKAGE**  
**M SUFFIX ... FK PACKAGE**

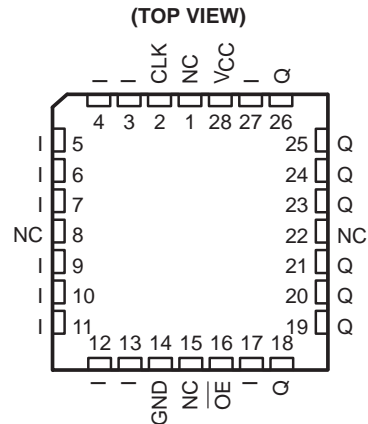

Pin assignments in operating mode

NC – No internal connection



POST OFFICE BOX 655303 • DALLAS, TEXAS 75265

functional block diagrams (positive logic)

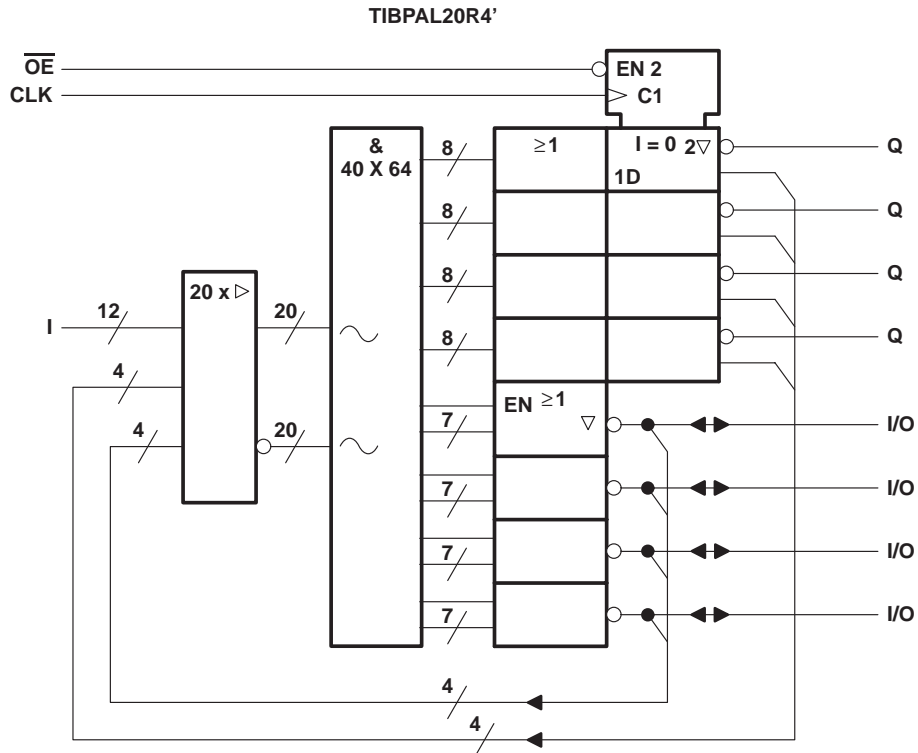
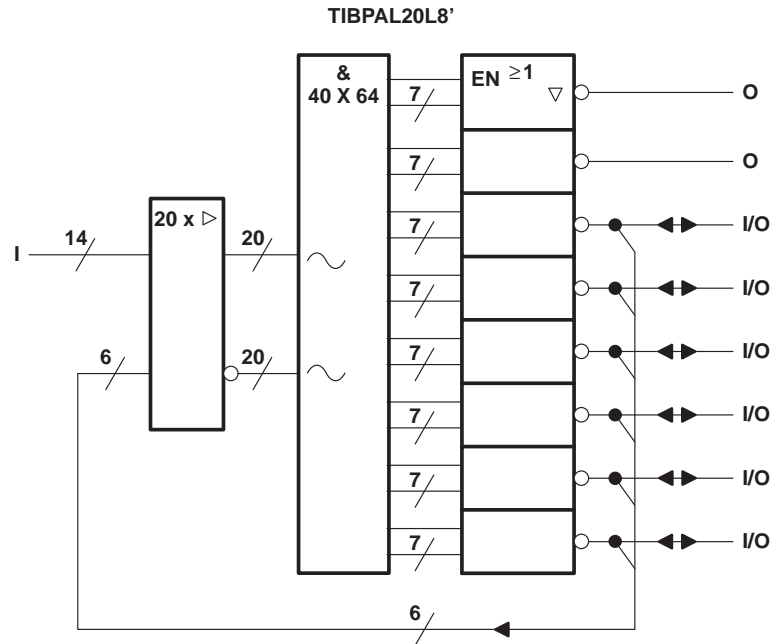

~ denotes fused inputs

TIBPAL20R6-7C, TIBPAL20R8-7C  
 TIBPAL20R6-10M, TIBPAL20R8-10M  
 HIGH-PERFORMANCE *IMPACT-X*™ PAL® CIRCUITS  
 SRPS005D – D3307, OCTOBER 1989 – REVISED NOVEMBER 1995

functional block diagrams (positive logic)

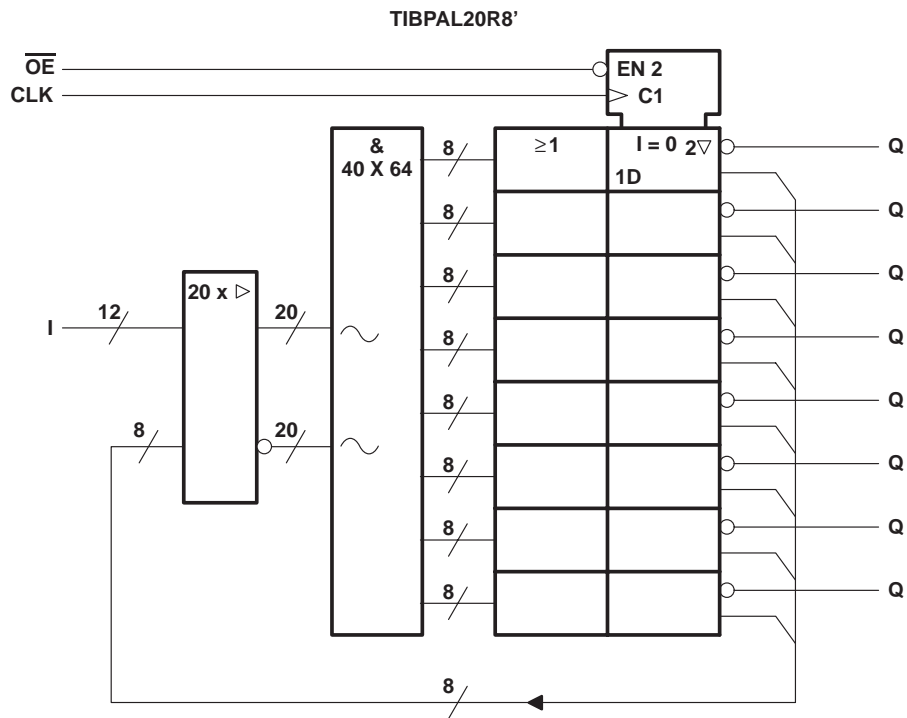
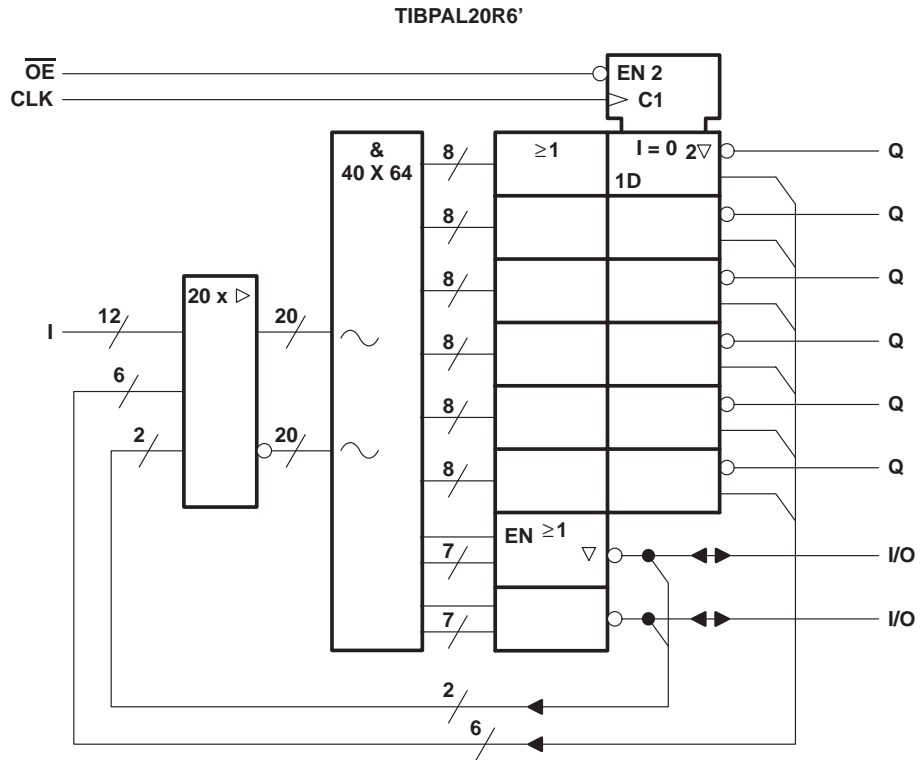

~ denotes fused inputs



**logic diagram (positive logic)**

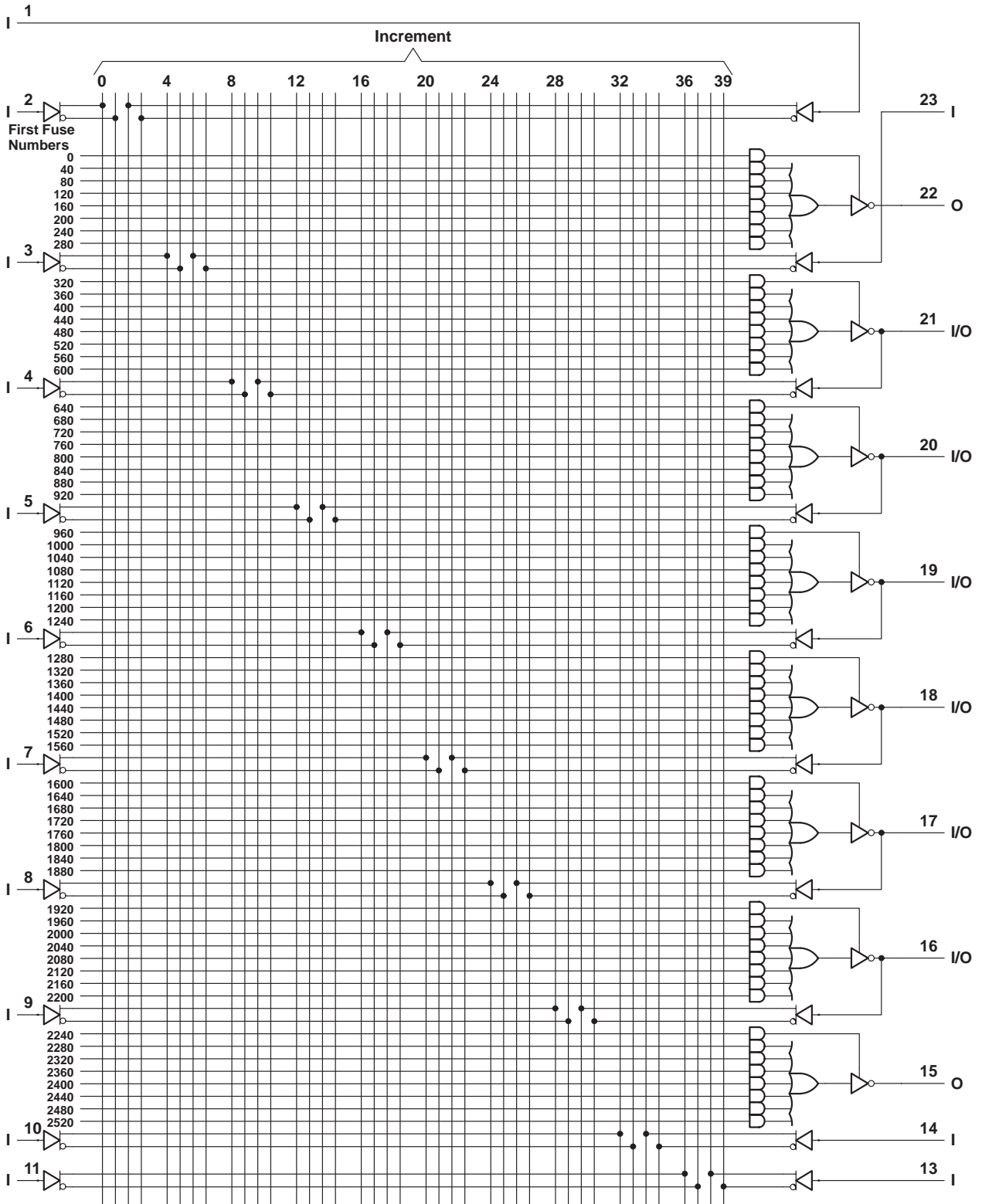

Fuse number = First fuse number + Increment  
 Pin numbers shown are for JT and NT packages.



**TIBPAL20R4-7C**  
**TIBPAL20R4-10M**  
**HIGH-PERFORMANCE *IMPACT-X*™ PAL® CIRCUITS**  
 SRPS005D – D3307, OCTOBER 1989 – REVISED NOVEMBER 1995

**logic diagram (positive logic)**

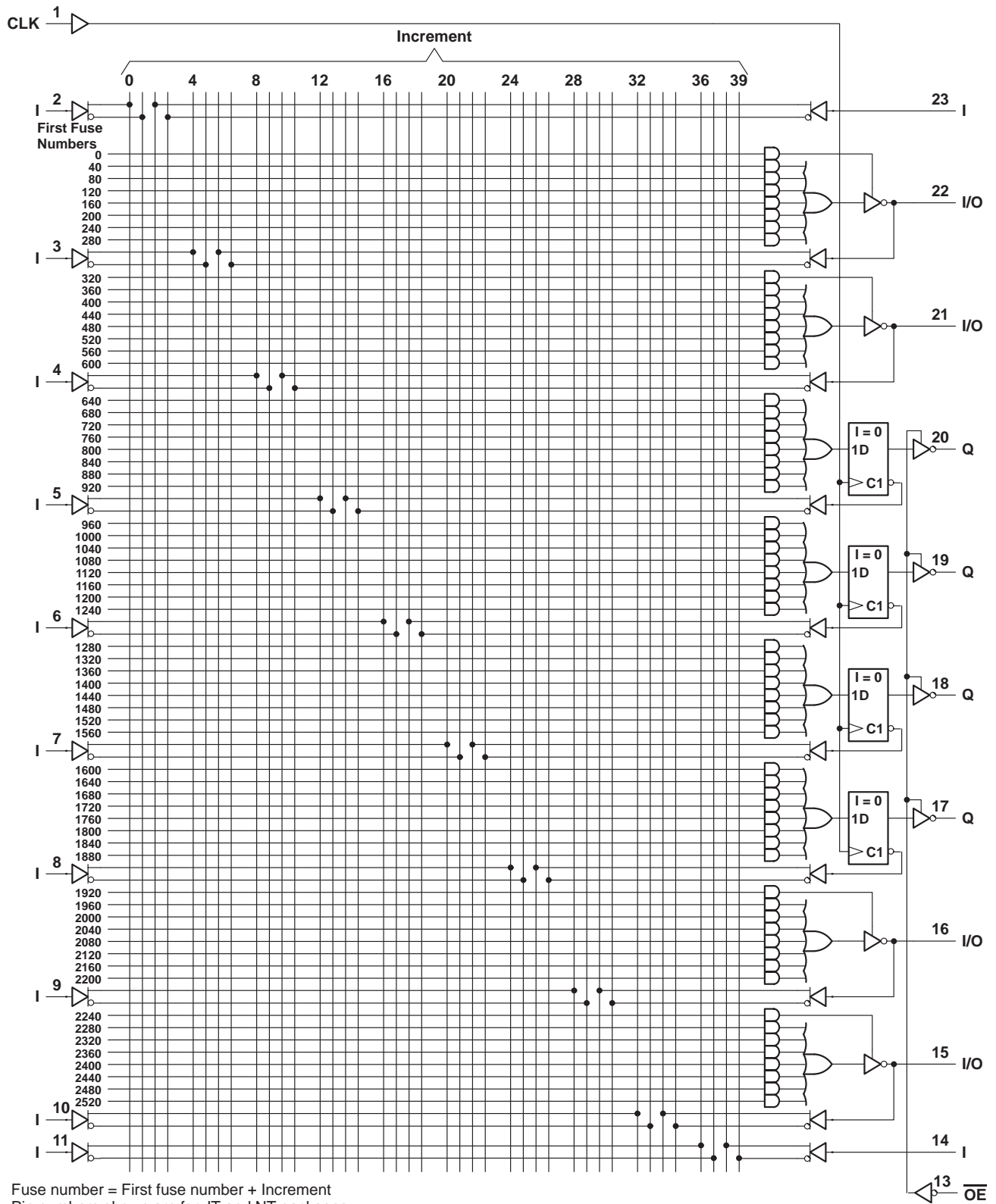

logic diagram (positive logic)

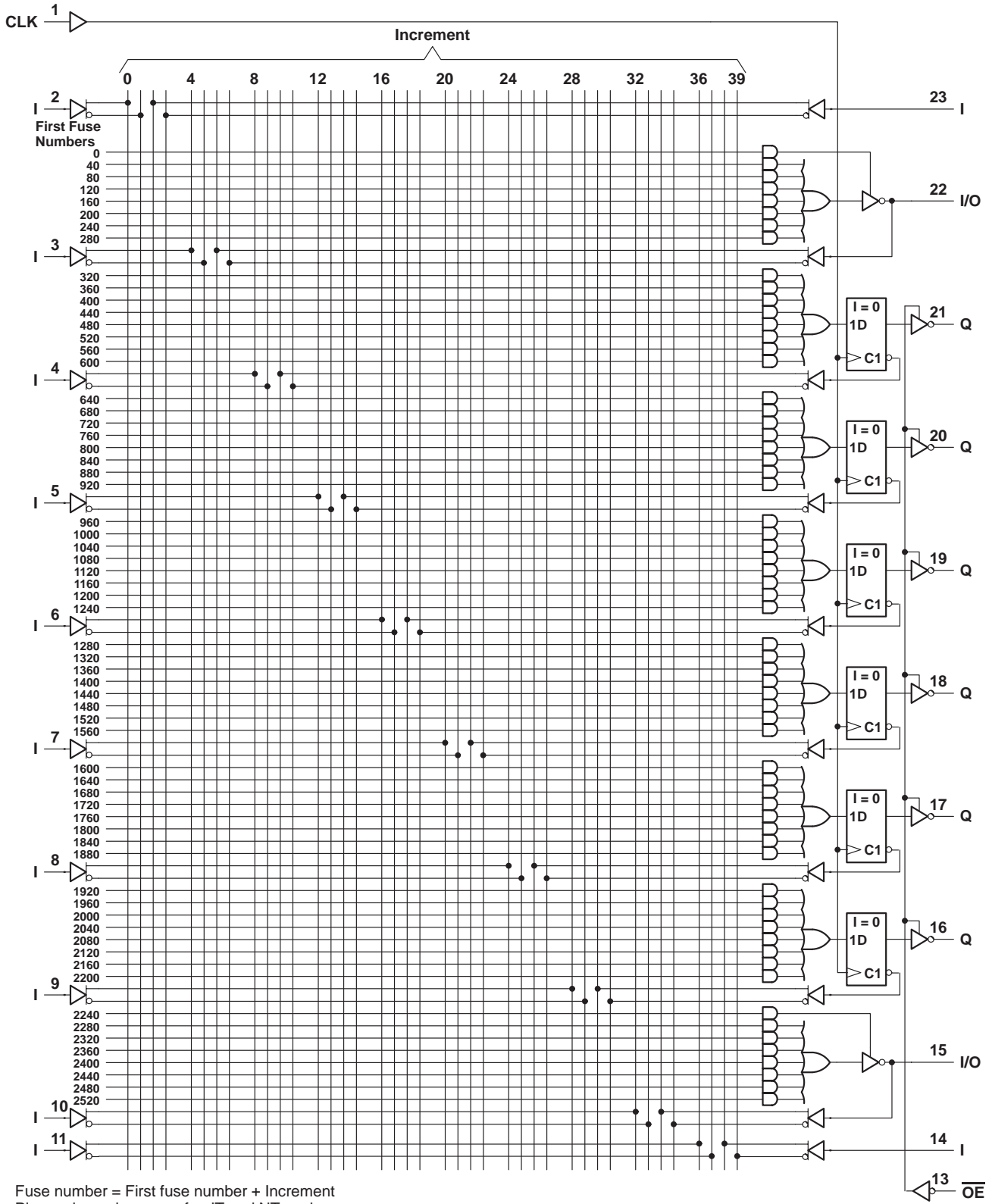

**TIBPAL20R8-7C**  
**TIBPAL20R8-10M**  
**HIGH-PERFORMANCE *IMPACT-X*™ PAL® CIRCUITS**  
 SRPS005D – D3307, OCTOBER 1989 – REVISED NOVEMBER 1995

**logic diagram (positive logic)**

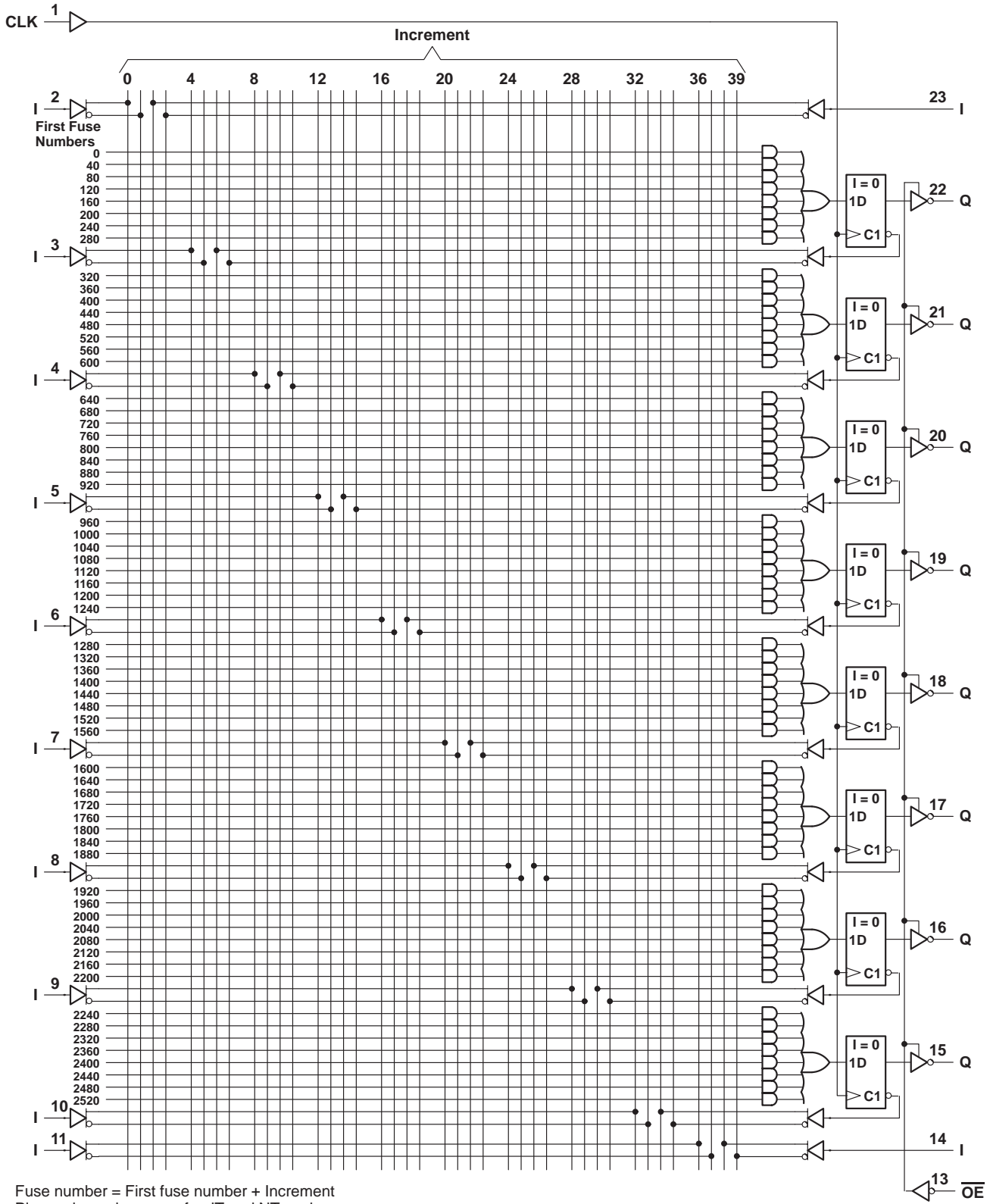

Fuse number = First fuse number + Increment  
 Pin numbers shown are for JT and NT packages.



POST OFFICE BOX 655303 • DALLAS, TEXAS 75265



# TIBPAL20L8-7C, TIBPAL20R4-7C, TIBPAL20R6-7C, TIBPAL20R8-7C HIGH-PERFORMANCE *IMPACT-X*<sup>™</sup> *PAL*<sup>®</sup> CIRCUITS

SRPS005D – D3307, OCTOBER 1989 – REVISED NOVEMBER 1995

## absolute maximum ratings over operating free-air temperature range (unless otherwise noted)

Supply voltage, $V_{CC}$ (see Note 1) .....	7 V
Input voltage (see Note 1) .....	5.5 V
Voltage applied to disabled output (see Note 1) .....	5.5 V
Operating free-air temperature range .....	0°C to 75°C
Storage temperature range .....	–65°C to 150°C

NOTE 1: These ratings apply except for programming pins during a programming cycle.

## recommended operating conditions

		MIN	NOM	MAX	UNIT
$V_{CC}$	Supply voltage	4.75	5	5.25	V
$V_{IH}$	High-level input voltage (see Note 2)	2		5.5	V
$V_{IL}$	Low-level input voltage (see Note 2)			0.8	V
$I_{OH}$	High-level output current			–3.2	mA
$I_{OL}$	Low-level output current			24	mA
$f_{clock}^{\dagger}$	Clock frequency	0		100	MHz
$t_w^{\dagger}$	Pulse duration, clock (see Note 2)	High	5		ns
		Low	5		
$t_{su}^{\dagger}$	Setup time, input or feedback before clock $\uparrow$	7			ns
$t_h^{\dagger}$	Hold time, input or feedback after clock $\uparrow$	0			ns
$T_A$	Operating free-air temperature	0	25	75	°C

<sup>†</sup>  $f_{clock}$ ,  $t_w$ ,  $t_{su}$ , and  $t_h$  do not apply for TIBPAL20L8'.

NOTE 2: These are absolute voltage levels with respect to the ground pin of the device and include all overshoots due to system and/or tester noise. Testing these parameters should not be attempted without suitable equipment.



# TIBPAL20L8-7C, TIBPAL20R4-7C, TIBPAL20R6-7C, TIBPAL20R8-7C HIGH-PERFORMANCE *IMPACT-X*™ *PAL*® CIRCUITS

SRPS005D – D3307, OCTOBER 1989 – REVISED NOVEMBER 1995

## electrical characteristics over recommended operating free-air temperature range

PARAMETER	TEST CONDITIONS		MIN	TYP†	MAX	UNIT
$V_{IK}$	$V_{CC} = 4.75\text{ V}$ ,	$I_I = -18\text{ mA}$	-0.8	-1.5		V
$V_{OH}$	$V_{CC} = 4.75\text{ V}$ ,	$I_{OH} = -3.2\text{ mA}$	2.4	3.2		V
$V_{OL}$	$V_{CC} = 4.75\text{ V}$ ,	$I_{OL} = 24\text{ mA}$	0.3	0.5		V
$I_{OZH}^{\ddagger}$	$V_{CC} = 5.25\text{ V}$ ,	$V_O = 2.7\text{ V}$			100	$\mu\text{A}$
$I_{OZL}^{\ddagger}$	$V_{CC} = 5.25\text{ V}$ ,	$V_O = 0.4\text{ V}$			-100	$\mu\text{A}$
$I_I$	$V_{CC} = 5.25\text{ V}$ ,	$V_I = 5.5\text{ V}$			100	$\mu\text{A}$
$I_{IH}^{\ddagger}$	$V_{CC} = 5.25\text{ V}$ ,	$V_I = 2.7\text{ V}$			25	$\mu\text{A}$
$I_{IL}^{\ddagger}$	$V_{CC} = 5.25\text{ V}$ ,	$V_I = 0.4\text{ V}$	-80	-250		$\mu\text{A}$
$I_{OS}^{\S}$	$V_{CC} = 5.25\text{ V}$ ,	$V_O = 0.5\text{ V}$	-30	-70	-130	mA
$I_{CC}$	$V_{CC} = 5.25\text{ V}$ ,	$V_I = 0$ , Outputs open	150	210		mA
$C_i$	$f = 1\text{ MHz}$ ,	$V_I = 2\text{ V}$		5		pF
$C_o$	$f = 1\text{ MHz}$ ,	$V_O = 2\text{ V}$		6		pF
$C_{clk}$	$f = 1\text{ MHz}$ ,	$V_{CLK} = 2\text{ V}$		6		pF

## switching characteristics over recommended ranges of supply voltage and operating free-air temperature (unless otherwise noted)

PARAMETER	FROM (INPUT)	TO (OUTPUT)	TEST CONDITION	MIN	TYP†	MAX	UNIT	
$f_{max}^{\parallel}$	without feedback		R1 = 200 $\Omega$ , R2 = 390 $\Omega$ , See Figure 6	100			MHz	
	with internal feedback (counter configuration)			100				
	with external feedback			74				
$t_{pd}$	I, I/O	O, I/O		1 or 2 outputs switching	3	5.5	7	ns
				8 outputs switching	3	6	7.5	
$t_{pd}$	CLK $\uparrow$			Q	2	4	6.5	ns
$t_{pd}^{\#}$	CLK $\uparrow$			Feedback input			3	ns
$t_{en}$	OE $\downarrow$			Q		4	7.5	ns
$t_{dis}$	OE $\uparrow$			Q		4	7.5	ns
$t_{en}$	I, I/O			O, I/O		6	9	ns
$t_{dis}$	I, I/O		O, I/O		6	9	ns	
$t_{sk(o)}^{\parallel\parallel}$	Skew between registered outputs			0.5			ns	

† All typical values are at  $V_{CC} = 5\text{ V}$ ,  $T_A = 25^\circ\text{C}$ .

‡ I/O leakage is the worst case of  $I_{OZL}$  and  $I_{IL}$  or  $I_{OZH}$  and  $I_{IH}$  respectively.

§ Not more than one output should be shorted at a time, and the duration of the short circuit should not exceed one second.  $V_O$  is set at 0.5 V to avoid test problems caused by test equipment ground degradation.

¶ See section for  $f_{max}$  specifications.

# This parameter applies to TIBPAL20R4' and TIBPAL20R6' only (see Figure 4 for illustration) and is calculated from the measured  $f_{max}$  with internal feedback in the counter configuration.

|| This parameter is the measurement of the difference between the fastest and slowest  $t_{pd}$  (CLK-to-Q) observed when multiple registered outputs are switching in the same direction.



POST OFFICE BOX 655303 • DALLAS, TEXAS 75265

# TIBPAL20L8-10M, TIBPAL20R4-10M, TIBPAL20R6-10M, TIBPAL20R8-10M HIGH-PERFORMANCE *IMPACT-X*<sup>TM</sup> *PAL*<sup>®</sup> CIRCUITS

SRPS005D – D3307, OCTOBER 1989 – REVISED NOVEMBER 1995

## absolute maximum ratings over operating free-air temperature range (unless otherwise noted)

Supply voltage, $V_{CC}$ (see Note 1) .....	7 V
Input voltage (see Note 1) .....	5.5 V
Voltage applied to disabled output (see Note 1) .....	5.5 V
Operating free-air temperature range .....	–55°C to 125°C
Storage temperature range .....	–65°C to 150°C

NOTE 1: These ratings apply except for programming pins during a programming cycle.

## recommended operating conditions

		MIN	NOM	MAX	UNIT
$V_{CC}$	Supply voltage	4.5	5	5.5	V
$V_{IH}$	High-level input voltage	2		5.5	V
$V_{IL}$	Low-level input voltage			0.8	V
$I_{OH}$	High-level output current			–2	mA
$I_{OL}$	Low-level output current			12	mA
$f_{clock}^{\dagger}$	Clock frequency	0		62.5	MHz
$t_w^{\dagger}$	Pulse duration, clock (see Note 2)	High		8	ns
		Low		8	
$t_{su}^{\dagger}$	Setup time, input or feedback before clock $\uparrow$	10			ns
$t_h^{\dagger}$	Hold time, input or feedback after clock $\uparrow$	0			ns
$T_A$	Operating free-air temperature	–55	25	125	°C

<sup>†</sup>  $f_{clock}$ ,  $t_w$ ,  $t_{su}$ , and  $t_h$  do not apply for TIBPAL20L8'.

NOTE 2: These are absolute voltage levels with respect to the ground pin of the device and include all overshoots due to system and/or tester noise. Testing these parameters should not be attempted without suitable equipment.



# TIBPAL20L8-10M, TIBPAL20R4-10M, TIBPAL20R6-10M, TIBPAL20R8-10M HIGH-PERFORMANCE *IMPACT-X*™ *PAL*® CIRCUITS

SRPS005D – D3307, OCTOBER 1989 – REVISED NOVEMBER 1995

## electrical characteristics over recommended operating free-air temperature range

PARAMETER	TEST CONDITIONS		MIN	TYP†	MAX	UNIT
$V_{IK}$	$V_{CC} = 4.5\text{ V}$ ,	$I_I = -18\text{ mA}$		-0.8	-1.5	V
$V_{OH}$	$V_{CC} = 4.5\text{ V}$ ,	$I_{OH} = -2\text{ mA}$	2.4	3.2		V
$V_{OL}$	$V_{CC} = 4.5\text{ V}$ ,	$I_{OL} = 12\text{ mA}$		0.3	0.5	V
$I_{OZH}‡$	$V_{CC} = 5.5\text{ V}$ ,	$V_O = 2.7\text{ V}$			20	$\mu\text{A}$
$I_{OZL}‡$	$V_{CC} = 5.5\text{ V}$ ,	$V_O = 0.4\text{ V}$			-0.1	mA
$I_I$	$V_{CC} = 5.5\text{ V}$ ,	$V_I = 5.5\text{ V}$			1	mA
$I_{IH}‡$	I/O ports	$V_{CC} = 5.5\text{ V}$ ,	$V_I = 2.7\text{ V}$		100	$\mu\text{A}$
	All others				25	
$I_{IL}‡$	$V_{CC} = 5.5\text{ V}$ ,	$V_I = 0.4\text{ V}$		-0.08	-0.25	mA
$I_{OS}§$	$V_{CC} = 5.5\text{ V}$ ,	$V_O = 0.5\text{ V}$	-30	-70	-130	mA
$I_{CC}$	$V_{CC} = 5.5\text{ V}$ ,	Outputs open $V_I = 0$ , $OE = V_{IH}$		140	220	mA
$C_i$	$f = 1\text{ MHz}$ ,	$V_I = 2\text{ V}$		5		pF
$C_o$	$f = 1\text{ MHz}$ ,	$V_O = 2\text{ V}$		6		pF
$C_{clk}$	$f = 1\text{ MHz}$ ,	$V_{CLK} = 2\text{ V}$		6		pF

## switching characteristics over recommended ranges of supply voltage and operating free-air temperature (unless otherwise noted)

PARAMETER	FROM (INPUT)	TO (OUTPUT)	TEST CONDITION	MIN	TYP†	MAX	UNIT	
$f_{max}¶$	without feedback		R1 = 390 $\Omega$ , R2 = 750 $\Omega$ , See Figure 6	62.5			MHz	
	with internal feedback (counter configuration)			62.5				
	with external feedback			50				
$t_{pd}$	I, I/O	O, I/O			1	6	10	ns
$t_{pd}$	CLK↑	Q			1	4	10	ns
$t_{pd}^\#$	CLK↑	Feedback input					5	ns
$t_{en}$	OE↓	Q			1	4	10	ns
$t_{dis}$	OE↑	Q			1	4	10	ns
$t_{en}$	I, I/O	O, I/O			1	6	12	ns
$t_{dis}$	I, I/O	O, I/O			1	6	10	ns

† All typical values are at  $V_{CC} = 5\text{ V}$ ,  $T_A = 25^\circ\text{C}$ .

‡ I/O leakage is the worst case of  $I_{OZL}$  and  $I_{IL}$  or  $I_{OZH}$  and  $I_{IH}$  respectively.

§ Not more than one output should be shorted at a time, and the duration of the short circuit should not exceed one second.  $V_O$  is set at 0.5 V to avoid test problems caused by test equipment ground degradation.

¶ See section for  $f_{max}$  specifications.  $f_{max}$  with external feedback is not production tested but is calculated from the equation found in the  $f_{max}$  specification section.

# This parameter applies to TIBPAL20R4' and TIBPAL20R6' only (see Figure 4 for illustration) and is calculated from the measured  $f_{max}$  with internal feedback in the counter configuration.



POST OFFICE BOX 655303 • DALLAS, TEXAS 75265

### programming information

Texas Instruments programmable logic devices can be programmed using widely available software and inexpensive device programmers.

Complete programming specifications, algorithms, and the latest information on hardware, software, and firmware are available upon request. Information on programmers capable of programming Texas Instruments programmable logic is also available, upon request, from the nearest TI field sales office, local authorized TI distributor, or by calling Texas Instruments at (214) 997-5666.

### preload procedure for registered outputs (see Figure 1 and Note 3)

The output registers can be preloaded to any desired state during device testing. This permits any state to be tested without having to step through the entire state-machine sequence. Each register is preloaded individually by following the steps given below.

- Step 1. With  $V_{CC}$  at 5 volts and Pin 1 at  $V_{IL}$ , raise Pin 13 to  $V_{IHH}$ .
- Step 2. Apply either  $V_{IL}$  or  $V_{IH}$  to the output corresponding to the register to be preloaded.
- Step 3. Pulse Pin 1, clocking in preload data.
- Step 4. Remove output voltage, then lower Pin 13 to  $V_{IL}$ . Preload can be verified by observing the voltage level at the output pin.

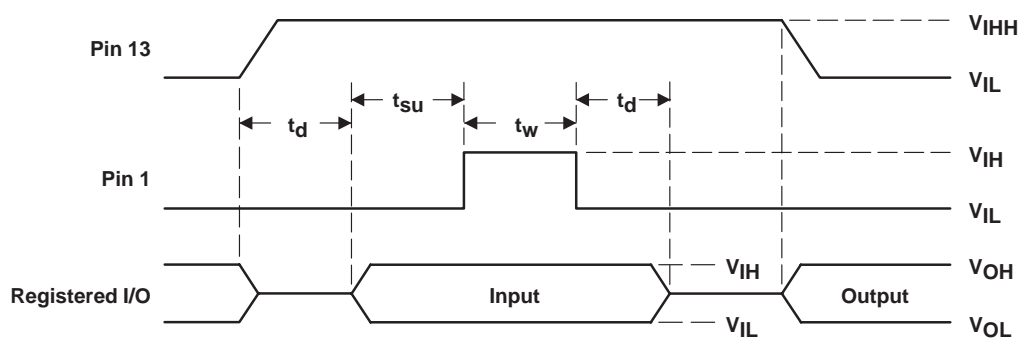

**Figure 1. Preload Waveforms**

NOTE 3:  $t_d = t_{su} = t_h = 100$  ns to 1000 ns  $V_{IHH} = 10.25$  V to 10.75 v

TIBPAL20L8-7C, TIBPAL20R4-7C, TIBPAL20R6-7C, TIBPAL20R8-7C  
TIBPAL20L8-10M, TIBPAL20R4-10M, TIBPAL20R6-10M, TIBPAL20R8-10M  
HIGH-PERFORMANCE *IMPACT-X*™ *PAL*® CIRCUITS

SRPS005D – D3307, OCTOBER 1989 – REVISED NOVEMBER 1995

**power-up reset (see Figure 2)**

Following power up, all registers are reset to zero. This feature provides extra flexibility to the system designer and is especially valuable in simplifying state-machine initialization. To ensure a valid power-up reset, it is important that the rise of  $V_{CC}$  be monotonic. Following power-up reset, a low-to-high clock transition must not occur until all applicable input and feedback setup times are met.

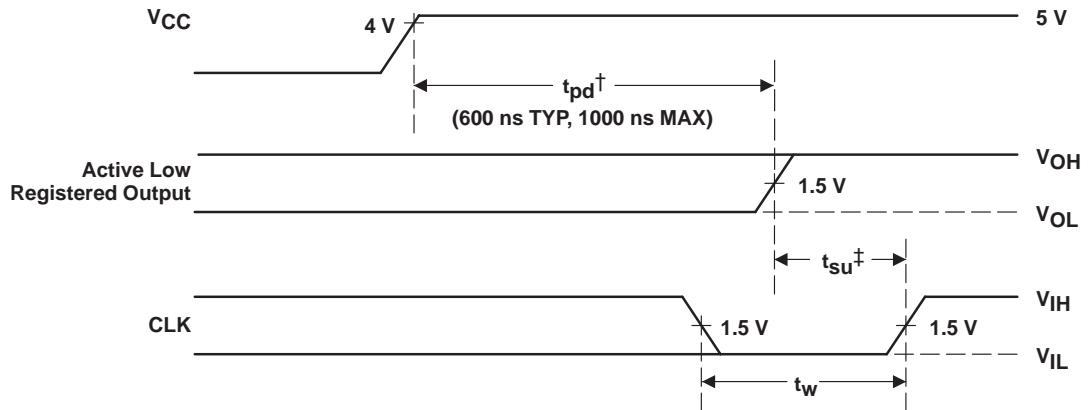

† This is the power-up reset time and applies to registered outputs only. The values shown are from characterization data.

‡ This is the setup time for input or feedback.

**Figure 2. Power-Up Reset Waveforms**

### $f_{\max}$ SPECIFICATIONS

#### $f_{\max}$ without feedback, see Figure 3

In this mode, data is presented at the input to the flip-flop and clocked through to the Q output with no feedback. Under this condition, the clock period is limited by the sum of the data setup time and the data hold time ( $t_{su} + t_h$ ). However, the minimum  $f_{\max}$  is determined by the minimum clock period ( $t_w \text{ high} + t_w \text{ low}$ ).

Thus,  $f_{\max}$  without feedback =  $\frac{1}{(t_{w \text{ high}} + t_{w \text{ low}})}$  or  $\frac{1}{(t_{su} + t_h)}$ .

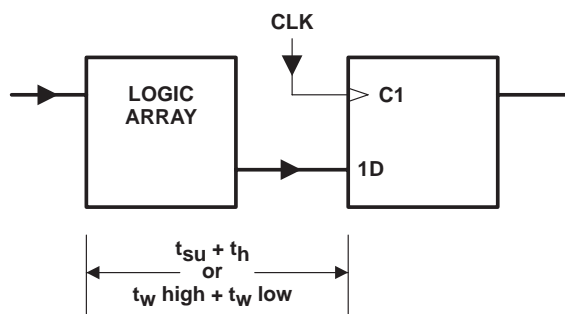

Figure 3.  $f_{\max}$  Without Feedback

#### $f_{\max}$ with internal feedback, see Figure 4

This configuration is most popular in counters and on-chip state-machine designs. The flip-flop inputs are defined by the device inputs and flip-flop outputs. Under this condition, the period is limited by the internal delay from the flip-flop outputs through the internal feedback and logic array to the inputs of the next flip-flop.

Thus,  $f_{\max}$  with internal feedback =  $\frac{1}{(t_{su} + t_{pd \text{ CLK-to-FB}})}$ .

Where  $t_{pd \text{ CLK-to-FB}}$  is the deduced value of the delay from CLK to the input of the logic array.

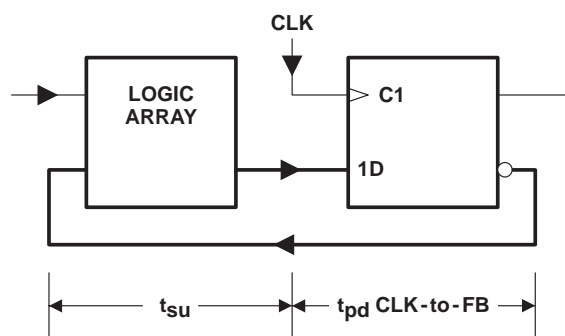

Figure 4.  $f_{\max}$  With Internal Feedback

**f<sub>max</sub> SPECIFICATIONS**

**f<sub>max</sub> with external feedback, see Figure 5**

This configuration is a typical state-machine design with feedback signals sent off-chip. This external feedback could go back to the device inputs or to a second device in a multi-chip state machine. The slowest path defining the period is the sum of the clock-to-output time and the input setup time for the external signals ( $t_{su} + t_{pd \text{ CLK-to-Q}}$ ).

$$\text{Thus, } f_{\text{max}} \text{ with external feedback} = \frac{1}{(t_{\text{su}} + t_{\text{pd CLK-to-Q}})}$$

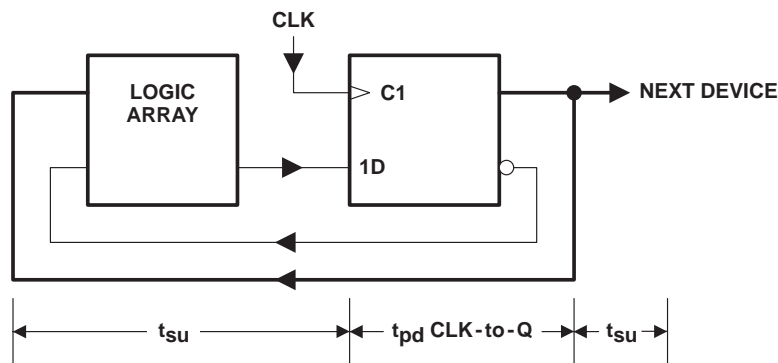

**Figure 5. f<sub>max</sub> With External Feedback**



PARAMETER MEASUREMENT INFORMATION

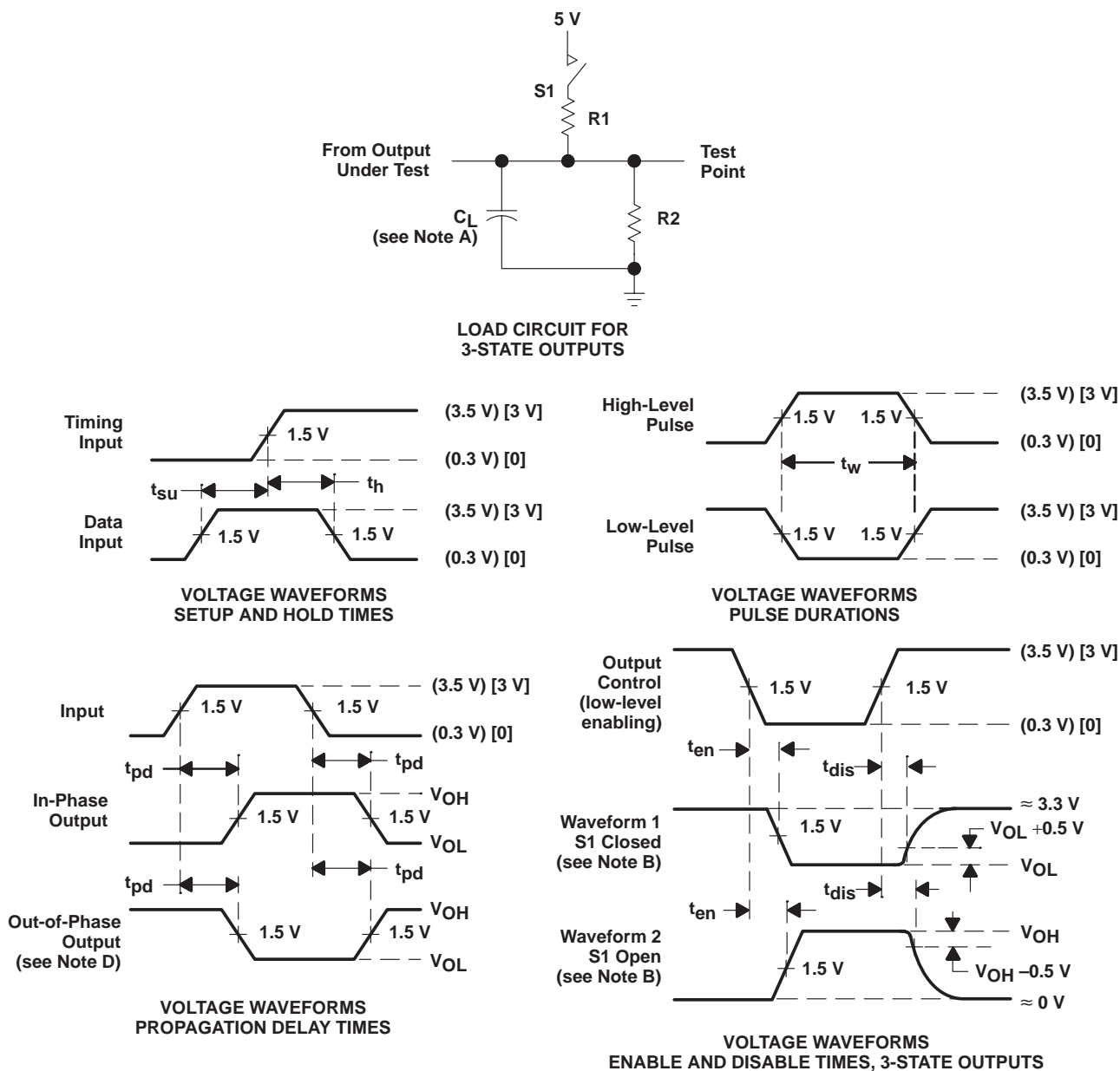

- NOTES: A.  $C_L$  includes probe and jig capacitance and is 50 pF for  $t_{pd}$  and  $t_{en}$ , 5 pF for  $t_{dis}$ .  
B. Waveform 1 is for an output with internal conditions such that the output is low except when disabled by the output control. Waveform 2 is for an output with internal conditions such that the output is high except when disabled by the output control.  
C. All input pulses have the following characteristics:  $PRR \leq 10$  MHz,  $t_r$  and  $t_f \leq 2$  ns, duty cycle = 50%. For C suffix, use the voltage levels indicated in parentheses ( ). For M suffix, use the voltage levels indicated in brackets [ ].  
D. When measuring propagation delay times of 3-state outputs, switch S1 is closed.  
E. Equivalent loads may be used for testing.

Figure 6. Load Circuit and Voltage Waveforms

TIBPAL20L8-7C, TIBPAL20R4-7C, TIBPAL20R6-7C, TIBPAL20R8-7C  
 TIBPAL20L8-10M, TIBPAL20R4-10M, TIBPAL20R6-10M, TIBPAL20R8-10M  
 HIGH-PERFORMANCE *IMPACT-X*™ *PAL*® CIRCUITS

SRPS005D – D3307, OCTOBER 1989 – REVISED NOVEMBER 1995

TYPICAL CHARACTERISTICS

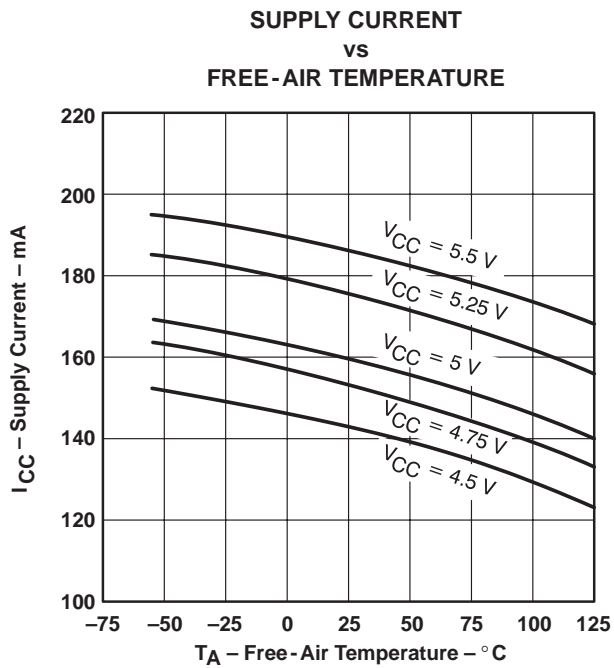

Figure 7

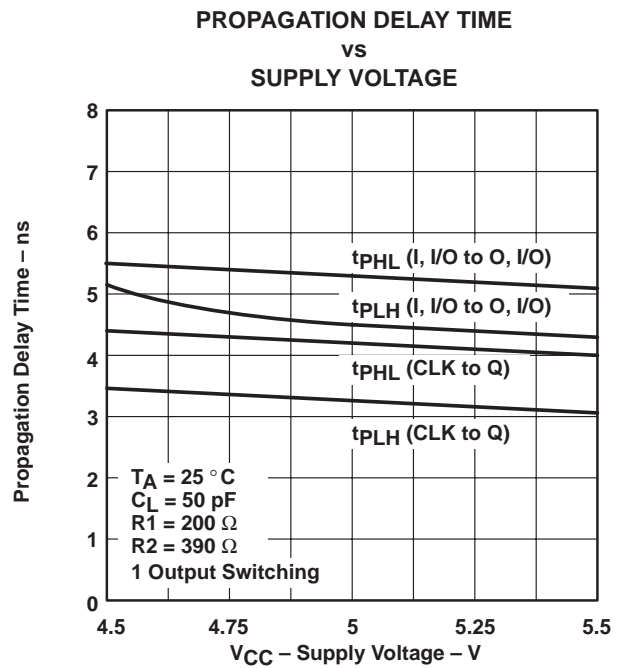

Figure 8

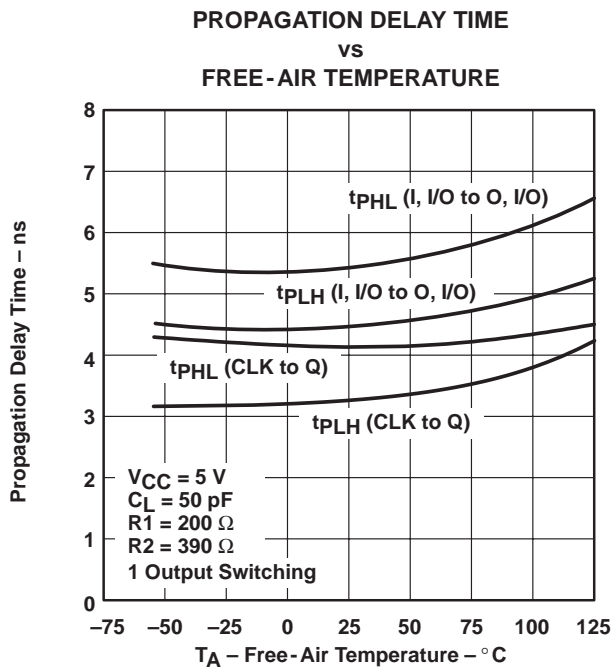

Figure 9

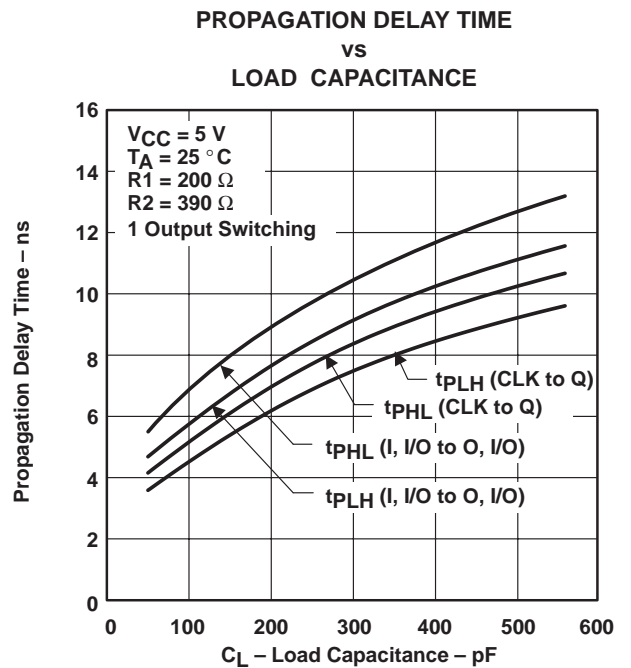

Figure 10

TIBPAL20L8-7C, TIBPAL20R4-7C, TIBPAL20R6-7C, TIBPAL20R8-7C  
 TIBPAL20L8-10M, TIBPAL20R4-10M, TIBPAL20R6-10M, TIBPAL20R8-10M  
 HIGH-PERFORMANCE *IMPACT-X*™ PAL® CIRCUITS  
 SRPS005D – D3307, OCTOBER 1989 – REVISED NOVEMBER 1995

TYPICAL CHARACTERISTICS

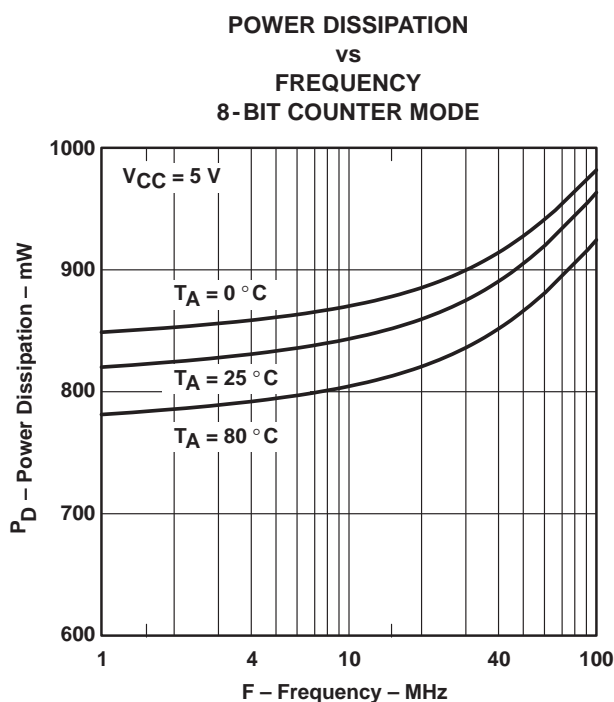

Figure 11

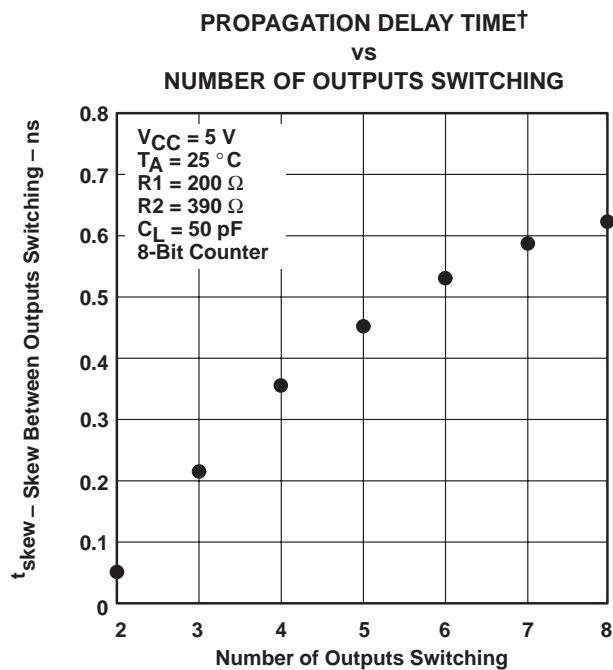

Figure 12

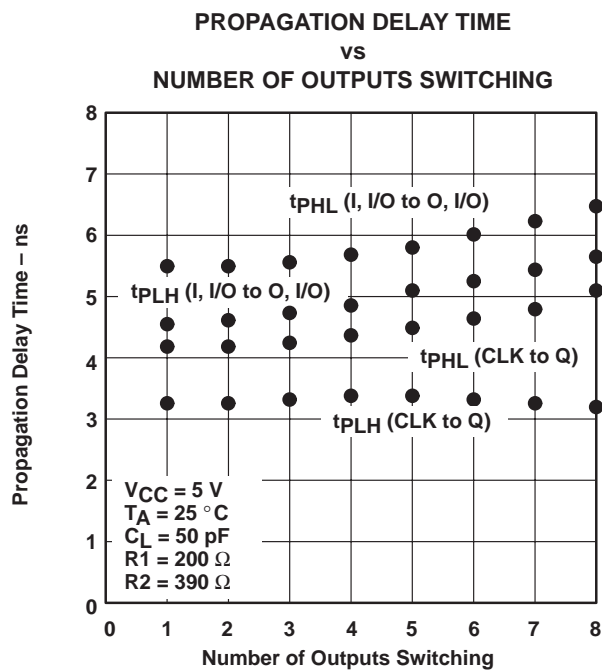

Figure 13

†Outputs switching in the same direction ( $t_{PLH}$  compared to  $t_{PLH}/t_{PHL}$  to  $t_{PHL}$ )

## **IMPORTANT NOTICE**

Texas Instruments and its subsidiaries (TI) reserve the right to make changes to their products or to discontinue any product or service without notice, and advise customers to obtain the latest version of relevant information to verify, before placing orders, that information being relied on is current and complete. All products are sold subject to the terms and conditions of sale supplied at the time of order acknowledgement, including those pertaining to warranty, patent infringement, and limitation of liability.

TI warrants performance of its semiconductor products to the specifications applicable at the time of sale in accordance with TI's standard warranty. Testing and other quality control techniques are utilized to the extent TI deems necessary to support this warranty. Specific testing of all parameters of each device is not necessarily performed, except those mandated by government requirements.

CERTAIN APPLICATIONS USING SEMICONDUCTOR PRODUCTS MAY INVOLVE POTENTIAL RISKS OF DEATH, PERSONAL INJURY, OR SEVERE PROPERTY OR ENVIRONMENTAL DAMAGE ("CRITICAL APPLICATIONS"). TI SEMICONDUCTOR PRODUCTS ARE NOT DESIGNED, AUTHORIZED, OR WARRANTED TO BE SUITABLE FOR USE IN LIFE-SUPPORT DEVICES OR SYSTEMS OR OTHER CRITICAL APPLICATIONS. INCLUSION OF TI PRODUCTS IN SUCH APPLICATIONS IS UNDERSTOOD TO BE FULLY AT THE CUSTOMER'S RISK.

In order to minimize risks associated with the customer's applications, adequate design and operating safeguards must be provided by the customer to minimize inherent or procedural hazards.

TI assumes no liability for applications assistance or customer product design. TI does not warrant or represent that any license, either express or implied, is granted under any patent right, copyright, mask work right, or other intellectual property right of TI covering or relating to any combination, machine, or process in which such semiconductor products or services might be or are used. TI's publication of information regarding any third party's products or services does not constitute TI's approval, warranty or endorsement thereof.