

SN5491A, SN54LS91, SN7491A, SN74LS91 8-BIT SHIFT REGISTERS

SDLS126 - MARCH 1974 - REVISED MARCH 1988

- For applications in:
Digital Computer Systems
Data-Handling Systems
Control Systems

SN5491A, SN54LS91 . . . J PACKAGE
SN7491A . . . N PACKAGE
SN74LS91 . . . D OR N PACKAGE
(TOP VIEW)

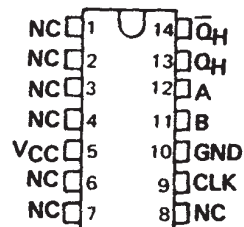

TYPE	TYPICAL MAXIMUM CLOCK FREQUENCY	TYPICAL POWER DISSIPATION
'91A	18 MHz	175 mW
'LS91	18 MHz	60 mW

description

These monolithic serial-in, serial-out, 8-bit shift registers utilize transistor-transistor logic (TTL) circuits and are composed of eight R-S master-slave flip-flops, input gating, and a clock driver. Single-rail data and input control are gated through inputs A and B and an internal inverter to form the complementary inputs to the first bit of the shift register. Drive for the internal common clock line is provided by an inverting clock driver. This clock pulse inverter/driver causes these circuits to shift information one bit on the positive edge of an input clock pulse.

SN5491A, SN54LS91 . . . W PACKAGE
(TOP VIEW)

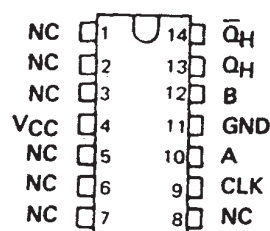

NC - No internal connection

schematics of inputs and outputs

FUNCTION TABLE

INPUTS AT t_n		OUTPUTS AT $t_n + 8$	
A	B	Q_H	\bar{Q}_H
H	H	H	L
L	X	L	H
X	L	L	H

t_n = Reference bit time,
clock low
 $t_n + 8$ = Bit time after 8
low-to-high
clock transitions.

logic symbol†

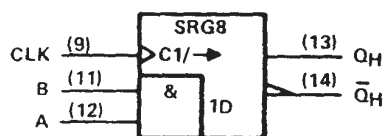

†This symbol is in accordance with ANSI/IEEE Std 91-1984 and IEC Publication 617-12.

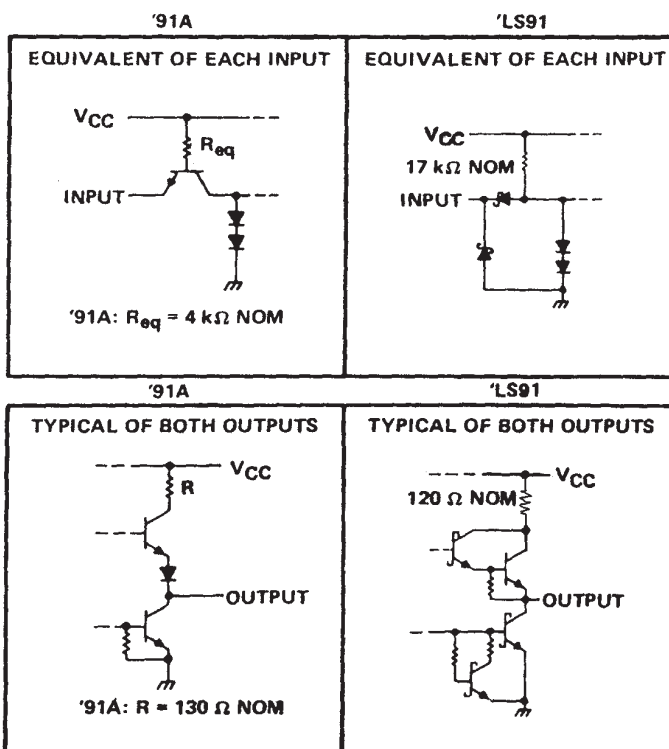

PRODUCTION DATA information is current as of publication date. Products conform to specifications per the terms of Texas Instruments standard warranty. Production processing does not necessarily include testing of all parameters.

**TEXAS
INSTRUMENTS**

POST OFFICE BOX 655303 • DALLAS, TEXAS 75265

Copyright © 1988, Texas Instruments Incorporated

SN5491A, SN54LS91, SN7491A, SN74LS91 8-BIT SHIFT REGISTERS

SDLS126 – MARCH 1974 – REVISED MARCH 1988

logic diagram (positive logic)

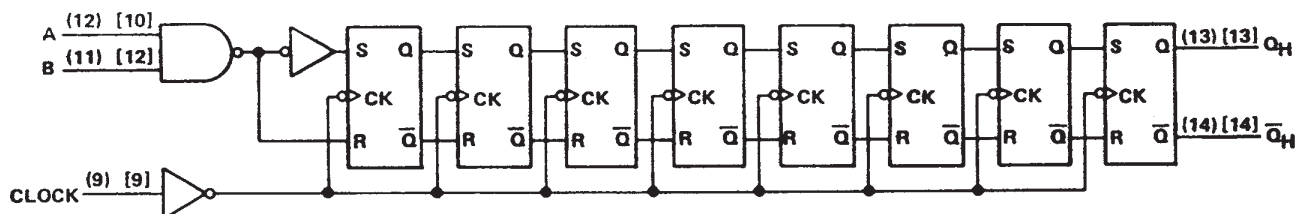

Pin numbers shown in () are for the D, J or N packages and pin numbers shown in [] are for the W package.

absolute maximum ratings over operating free-air temperature range (unless otherwise noted)

Supply voltage, V_{CC} (see Note 1)	7 V
Input voltage (see Note 2)	5.5 V
Operating free-air temperature range: SN5491A	-55°C to 125°C
SN7491A	0°C to 70°C
Storage temperature range	-65°C to 150°C

NOTES: 1. Voltage values are with respect to network ground terminal.
2. Input signals must be zero or positive with respect to network ground terminal.

recommended operating conditions

	SN5491A			SN7491A			UNIT
	MIN	NOM	MAX	MIN	NOM	MAX	
Supply voltage, V_{CC}	4.5	5	5.5	4.75	5	5.25	V
High-level output current, I_{OH}			-400			-400	μ A
Low-level output current, I_{OL}			16			16	mA
Width of clock input pulse, t_w	25			25			ns
Setup time, t_{SU} (see Figure 1)	25			25			ns
Hold time, t_h (see Figure 1)	0			0			ns
Operating free-air temperature, T_A	-55	125		0	70		°C

electrical characteristics over recommended operating free-air temperature range (unless otherwise noted)

PARAMETER	TEST CONDITIONS†	SN5491A			SN7491A			UNIT
		MIN	NOM	MAX	MIN	NOM	MAX	
V_{IH} High-level input voltage		2			2			V
V_{IL} Low-level input voltage				0.8			0.8	V
V_{OH} High-level output voltage	$V_{CC} = \text{MIN}$, $V_{IH} = 2 \text{ V}$, $V_{IL} = 0.8 \text{ V}$, $I_{OH} = -400 \mu\text{A}$	2.4	3.5		2.4	3.5		V
V_{OL} Low-level output voltage	$V_{CC} = \text{MIN}$, $V_{IH} = 2 \text{ V}$, $V_{IL} = 0.8 \text{ V}$, $I_{OL} = 16 \text{ mA}$		0.2	0.4		0.2	0.4	V
I_I Input current at maximum input voltage	$V_{CC} = \text{MAX}$, $V_I = 5.5 \text{ V}$			1			1	mA
I_{IH} High-level input current	$V_{CC} = \text{MAX}$, $V_I = 2.4 \text{ V}$			40			40	μ A
I_{IL} Low-level input current	$V_{CC} = \text{MAX}$, $V_I = 0.4 \text{ V}$			-1.6			-1.6	mA
I_{OS} Short-circuit output current‡	$V_{CC} = \text{MAX}$	-20		-57	-18		-57	mA
I_{CC} Supply current	$V_{CC} = \text{MAX}$, See Note 3		35	50		35	58	mA

† For conditions shown as MIN or MAX, use the appropriate value specified under recommended operating conditions.

‡ All typical values are at $V_{CC} = 5 \text{ V}$, $T_A = 25^\circ\text{C}$.

§ Not more than one output should be shorted at a time.

NOTE 3: I_{CC} is measured after the eighth clock pulse with the output open and A and B inputs grounded.

switching characteristics, $V_{CC} = 5 \text{ V}$, $T_A = 25^\circ\text{C}$

PARAMETER	TEST CONDITIONS	MIN	TYP	MAX	UNIT
f_{max} Maximum clock frequency	$C_L = 15 \text{ pF}$,	10	18		MHz
t_{PLH} Propagation delay time, low-to-high-level output	$R_L = 400 \Omega$,		24	40	ns
t_{PHL} Propagation delay time, high-to-low-level output	See Figure 1		27	40	ns



POST OFFICE BOX 655303 • DALLAS, TEXAS 75265

SN5491A, SN54LS91, SN7491A, SN74LS91 8-BIT SHIFT REGISTERS

SDLS126 – MARCH 1974 – REVISED MARCH 1988

absolute maximum ratings over operating free-air temperature range (unless otherwise noted)

Supply voltage, V_{CC} (see Note 1)	7 V
Input voltage	7 V
Operating free-air temperature range: SN54LS91	-55°C to 125°C
SN74LS91	0°C to 70°C
Storage temperature range	-65°C to 150°C

NOTES: 1. Voltage values are with respect to network ground terminal.

recommended operating conditions

	SN54LS91			SN74LS91			UNIT
	MIN	NOM	MAX	MIN	NOM	MAX	
Supply voltage, V_{CC}	4.5	5	5.5	4.75	5	5.25	V
High-level output current, I_{OH}			-400			-400	μ A
Low-level output current, I_{OL}			4			8	mA
Width of clock input pulse, t_w	25			25			ns
Setup time, t_{su} (see Figure 1)	25			25			ns
Hold time, t_h (see Figure 1)	0			0			ns
Operating free-air temperature, T_A	-55		125	0		70	°C

electrical characteristics over recommended operating free-air temperature range (unless otherwise noted)

PARAMETER	TEST CONDITIONS†	SN54LS91		SN74LS91		UNIT		
		MIN	TYP‡	MAX	MIN		TYP‡	MAX
V_{IH} High-level input voltage		2			2	V		
V_{IL} Low-level input voltage				0.7		0.8	V	
V_{IK} Input clamp voltage	$V_{CC} = \text{MIN}, I_I = -18 \text{ mA}$			-1.5		-1.5	V	
V_{OH} High-level output voltage	$V_{CC} = \text{MIN}, V_{IH} = 2 \text{ V}, V_{IL} = V_{IL \text{ max}}, I_{OH} = -400 \mu\text{A}$	2.5	3.5		2.7	3.5	V	
V_{OL} Low-level output voltage	$V_{CC} = \text{MIN}, V_{IH} = 2 \text{ V}, V_{IL} = V_{IL \text{ max}}$			0.25	0.4	0.25	0.4	V
	$I_{OL} = 4 \text{ mA}$					0.35	0.5	
	$I_{OL} = 8 \text{ mA}$							
I_I Input current at maximum input voltage	$V_{CC} = \text{MAX}, V_I = 7 \text{ V}$			0.1			0.1	mA
I_{IH} High-level input current	$V_{CC} = \text{MAX}, V_I = 2.7 \text{ V}$			20			20	μ A
I_{IL} Low-level input current	$V_{CC} = \text{MAX}, V_I = 0.4 \text{ V}$			-0.4			-0.4	mA
I_{OS} Short-circuit output current §	$V_{CC} = \text{MAX}$	-20		-100	-20		-100	mA
I_{CC} Supply current	$V_{CC} = \text{MAX},$ See Note 3		12	20		12	20	mA

† For conditions shown as MIN or MAX, use the appropriate value specified under recommended operating conditions.

‡ All typical values are at $V_{CC} = 5 \text{ V}, T_A = 25^\circ \text{C}$.

§ Not more than one output should be shorted at a time, and duration of the short-circuit should not exceed one second.

NOTE 3: I_{CC} is measured after the eighth clock pulse with the output open and A and B inputs grounded.

switching characteristics, $V_{CC} = 5 \text{ V}, T_A = 25^\circ \text{C}$

PARAMETER	TEST CONDITIONS	MIN	TYP	MAX	UNIT
f_{max} Maximum clock frequency	$C_L = 15 \text{ pF},$	10	18		MHz
t_{PLH} Propagation delay time, low-to-high-level output	$R_L = 2 \text{ k}\Omega,$		24	40	ns
t_{PHL} Propagation delay time, high-to-low-level output	See Figure 1		27	40	ns



SN5491A, SN54LS91, SN7491A, SN74LS91 8-BIT SHIFT REGISTERS

SDLS126 – MARCH 1974 – REVISED MARCH 1988

PARAMETER MEASUREMENT INFORMATION

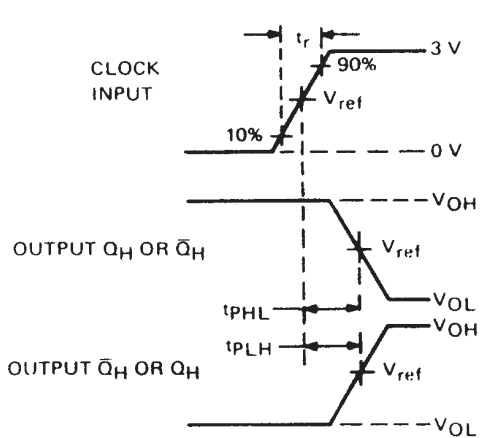
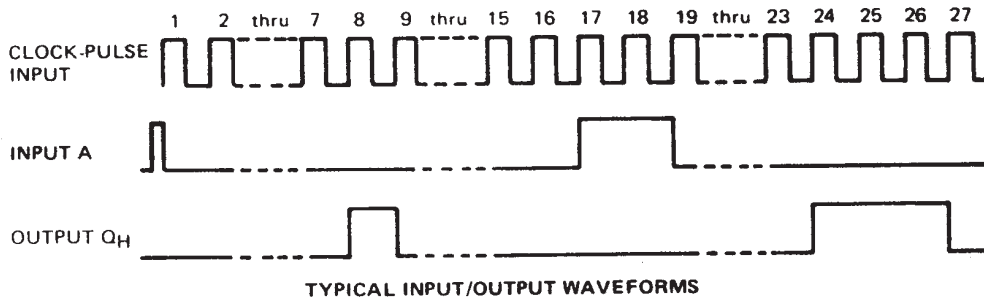
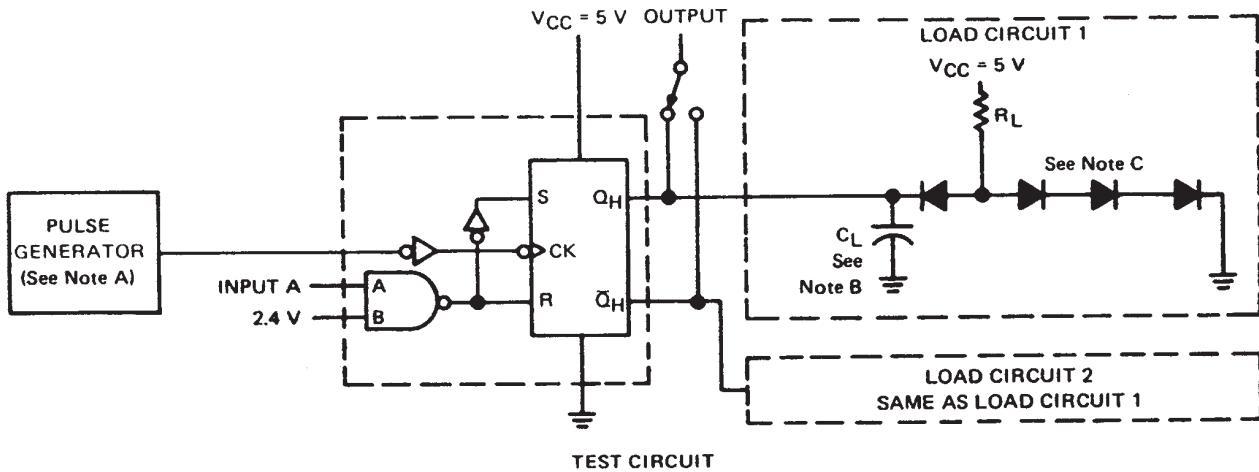

PROPAGATION DELAY TIMES VOLTAGE WAVEFORMS

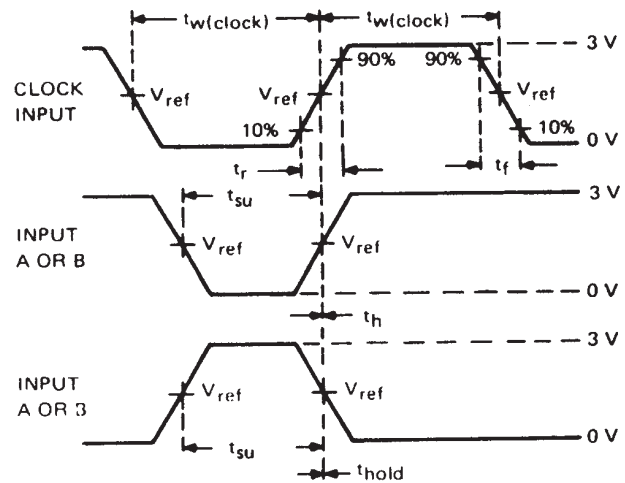

SWITCHING TIMES VOLTAGE WAVEFORMS

- NOTES: A. The generator has the following characteristics: $t_{w(\text{clock})} = 500 \text{ ns}$, $\text{PRR} \leq 1 \text{ MHz}$, $Z_{\text{out}} \approx 50 \Omega$. For SN5491A/SN7491A, $t_r \leq 10 \text{ ns}$ and $t_f \leq 10 \text{ ns}$; for SN54LS91, $t_r = 15 \text{ ns}$, and $t_f = 6 \text{ ns}$.
 B. C_L includes probe and jig capacitance.
 C. All diodes are 1N3064 or equivalent.
 D. For SN5491A/SN7491A, $V_{\text{ref}} = 1.5 \text{ V}$; for SN54LS91/SN74LS91, $V_{\text{ref}} = 1.3 \text{ V}$.

FIGURE 1—SWITCHING TIMES



POST OFFICE BOX 655303 • DALLAS, TEXAS 75265

IMPORTANT NOTICE

Texas Instruments and its subsidiaries (TI) reserve the right to make changes to their products or to discontinue any product or service without notice, and advise customers to obtain the latest version of relevant information to verify, before placing orders, that information being relied on is current and complete. All products are sold subject to the terms and conditions of sale supplied at the time of order acknowledgement, including those pertaining to warranty, patent infringement, and limitation of liability.

TI warrants performance of its semiconductor products to the specifications applicable at the time of sale in accordance with TI's standard warranty. Testing and other quality control techniques are utilized to the extent TI deems necessary to support this warranty. Specific testing of all parameters of each device is not necessarily performed, except those mandated by government requirements.

CERTAIN APPLICATIONS USING SEMICONDUCTOR PRODUCTS MAY INVOLVE POTENTIAL RISKS OF DEATH, PERSONAL INJURY, OR SEVERE PROPERTY OR ENVIRONMENTAL DAMAGE ("CRITICAL APPLICATIONS"). TI SEMICONDUCTOR PRODUCTS ARE NOT DESIGNED, AUTHORIZED, OR WARRANTED TO BE SUITABLE FOR USE IN LIFE-SUPPORT DEVICES OR SYSTEMS OR OTHER CRITICAL APPLICATIONS. INCLUSION OF TI PRODUCTS IN SUCH APPLICATIONS IS UNDERSTOOD TO BE FULLY AT THE CUSTOMER'S RISK.

In order to minimize risks associated with the customer's applications, adequate design and operating safeguards must be provided by the customer to minimize inherent or procedural hazards.

TI assumes no liability for applications assistance or customer product design. TI does not warrant or represent that any license, either express or implied, is granted under any patent right, copyright, mask work right, or other intellectual property right of TI covering or relating to any combination, machine, or process in which such semiconductor products or services might be or are used. TI's publication of information regarding any third party's products or services does not constitute TI's approval, warranty or endorsement thereof.