



Data sheet acquired from Harris Semiconductor
SCHS270A

February 1996

CD54/74FCT240, CD54/74FCT240AT, CD54/74FCT241, CD54/74FCT244, CD54/74FCT244AT

FCT Interface Logic Octal Buffers/Line Drivers, Three-State

Features

- CD54/74FCT240, CD54/74FCT240AT - Inverting
- CD54/74FCT241, CD54/74FCT244, CD54/74FCT244AT - Non-Inverting
- Buffered Inputs
- Typical Propagation Delay:
4.1ns at VCC = 5V, TA = 25°C (FCT240AT, FCT244AT)
- SCR-Latchup-Resistant BiCMOS Process and Circuit Design
- FCTXXX Types - Speed of Bipolar FAST®/AS/S;
FCTXXXAT Types - 30% Faster Than FAST/AS/S with
Significantly Reduced Power Consumption
- 48mA to 64mA Output Sink Current (Commercial/Extended Industrial)
- Output Voltage Swing Limited to 3.7V at VCC = 5V
- Controlled Output-Edge Rates
- Input/Output Isolation to VCC
- BiCMOS Technology with Low Quiescent Power

Ordering Information

PART NUMBER	TEMP. RANGE (°C)	PACKAGE
CD54/74FCT240E	-55 to 125, 0 to 70	20 Ld PDIP
CD54/74FCT240ATE	-55 to 125, 0 to 70	20 Ld PDIP
CD54/74FCT241E	-55 to 125, 0 to 70	20 Ld PDIP
CD54/74FCT244E	-55 to 125, 0 to 70	20 Ld PDIP
CD54/74FCT244ATE	-55 to 125, 0 to 70	20 Ld PDIP
CD54/74FCT240M	-55 to 125, 0 to 70	20 Ld SOIC
CD54/74FCT240ATM	-55 to 125, 0 to 70	20 Ld SOIC
CD54/74FCT241M	-55 to 125, 0 to 70	20 Ld SOIC
CD54/74FCT244M	-55 to 125, 0 to 70	20 Ld SOIC
CD54/74FCT244ATM	-55 to 125, 0 to 70	20 Ld SOIC
CD54/74FCT240SM	-55 to 125, 0 to 70	20 Ld SSOP
CD54/74FCT241SM	-55 to 125, 0 to 70	20 Ld SSOP
CD54/74FCT244SM	-55 to 125, 0 to 70	20 Ld SSOP
CD54FCT240H	-55 to 125	
CD54FCT241H	-55 to 125	
CD54FCT244H	-55 to 125	

Description

The CD54/74FCT240, 240AT, 241, 244 and 244AT three-state octal buffers/line drivers use a small-geometry BiCMOS technology. The output stage is a combination of bipolar and CMOS transistors that limits the output-HIGH level to two diode drops below VCC. This resultant lowering of output swing (0V to 3.7V) reduces power bus ringing (a source of EMI) and minimizes VCC bounce and ground bounce and their effects during simultaneous output switching. The output configuration also enhances switching speed and is capable of sinking 48mA to 64mA.

The CD54/74FCT240, 240AT, 244 and 244AT have active-LOW output enables (1OE, 2OE). The CD54/74FCT241 and CD54/74FCT241AT have one active-LOW (1OE) and one active-HIGH (2OE) output enable.

Functional Diagram

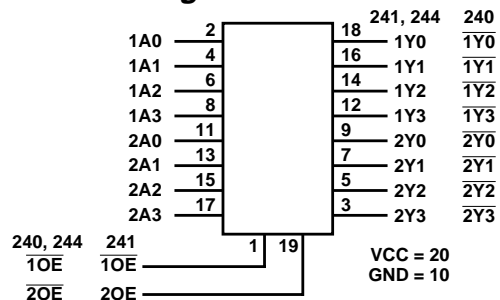

CD54/74FCT240, CD54/74FCT240AT TRUTH TABLE

INPUT	INPUT	OUTPUT
1OE, 2OE	A	Y
L	L	H
L	H	L
H	X	Z

CD54/74FCT244, CD54/74FCT244AT TRUTH TABLE

INPUT	INPUT	OUTPUT
1OE, 2OE	A	Y
L	L	H
L	H	L
H	X	Z

CD54/74FCT241 TRUTH TABLE

INPUT		OUTPUT	INPUT		OUTPUT
1OE	1A	1Y	2OE	2A	2Y
L	L	L	L	X	Z
L	H	H	H	L	L
H	X	Z	H	H	H

NOTE: H = High Voltage Level, L = LOW Voltage Level
X = Immaterial, Z = HIGH Impedance

FAST® is a registered trademark of Fairchild Semiconductor Corporation.

CD54/74FCT540, CD54/74FCT540AT, CD54/74FCT241, CD54/74FCT244, CD54/74FCT244AT

Switching Specifications FCT Series $t_r, t_f = 2.5\text{ns}$, $C_L = 50\text{pF}$, R_L - See Figure 2

PARAMETER	SYMBOL	V_{CC} (V)	+25°C		0°C to +70°C		-55°C to +125°C		+25°C		0°C to +70°C		-55°C to +125°C		UNITS
			TYP	MIN	MAX	MIN	MAX	TYP	MIN	MAX	MIN	MAX			
Propagation Delays															
Data to Outputs	FCT240/AT	t_{PLH}, t_{PHL}	5†	5	1.5	8	1.5	9	4.4	1.5	5.6	1.5	6.7	ns	
	FCT241	t_{PLH}, t_{PHL}	5	4	1.5	6.5	1.5	7	-	-	-	-	-	ns	
	FCT244/AT	t_{PLH}, t_{PHL}	5	4.5	1.5	6.5	1.5	7	3.8	1.5	5.3	1.5	6.2	µs	
Output Enable Times															
	FCT240/AT	t_{PZL}, t_{PZH}	5	7	1.5	10	1.5	10.5	4.7	1.5	6.2	1.5	7.7	µs	
	FCT241	t_{PZL}, t_{PZH}	5	5.5	1.5	8	1.5	8.5	-	-	-	-	-	ns	
	FCT244/AT	t_{PZL}, t_{PZH}	5	6	1.5	8	1.5	8.5	4.8	1.5	6.5	1.5	7.8	ns	
Output Disable Times															
	FCT240/AT	t_{PLZ}, t_{PHZ}	5	6	1.5	9.5	1.5	10	4	1.5	5.6	1.5	6.5	µs	
	FCT241	t_{PLZ}, t_{PHZ}	5	4.5	1.5	7	1.5	7.5	-	-	-	-	-	ns	
	FCT244/AT	t_{PLZ}, t_{PHZ}	5	5	1.5	7	1.5	7.5	4.5	1.5	5.8	1.5	6.8	µs	
Power Dissipation Capacitance															
	FCT240/AT	$C_{PD}\S$	-	38 Typical					38 Typical					µF	
	FCT241	$C_{PD}\S$	-	33 Typical					-					µF	
	FCT244/AT	$C_{PD}\S$	-	35 Typical					35 Typical					µF	
Min. (Valley) V_{OHV} During Switching of Other Outputs (Output Under Test Not Switching)															
		V_{OHV} See Figure 1	5	0.5 Typical at +25°C										V	
Max. (Peak) V_{OLP} During Switching of Other Outputs (Output Under Test Not Switching)															
		V_{OLP} See Figure 1	5	1 Typical at +25°C										V	
Input Capacitance															
		C_I	-	-	-	10	-	10	-	-	10	-	10	µF	
3-State Output Capacitance															
		C_O	-	-	-	15	-	15	-	-	15	-	15	µF	

† 5V: min. is at 5.5V, max. is at 4.5V.

5V: min. is at 5.25V for 0°C to +70°C, max. is at 4.75V for 0°C to +70°C, typ. is at 5V

§ C_{PD} , measured per function, is used to determine the dynamic power consumption. P_D (per package) = $V_{CC} I_{CC} + \sum (V_{CC}^2 f_i C_{PD} + V_O^2 f_o C_L + V_{CC} \Delta I_{CC} D)$ where:

V_{CC} = supply voltage

ΔI_{CC} = flow through current x unit load

C_L = output load capacitance

D = duty cycle of input high

f_o = output frequency

f_i = input frequency

IMPORTANT NOTICE

Texas Instruments and its subsidiaries (TI) reserve the right to make changes to their products or to discontinue any product or service without notice, and advise customers to obtain the latest version of relevant information to verify, before placing orders, that information being relied on is current and complete. All products are sold subject to the terms and conditions of sale supplied at the time of order acknowledgement, including those pertaining to warranty, patent infringement, and limitation of liability.

TI warrants performance of its semiconductor products to the specifications applicable at the time of sale in accordance with TI's standard warranty. Testing and other quality control techniques are utilized to the extent TI deems necessary to support this warranty. Specific testing of all parameters of each device is not necessarily performed, except those mandated by government requirements.

CERTAIN APPLICATIONS USING SEMICONDUCTOR PRODUCTS MAY INVOLVE POTENTIAL RISKS OF DEATH, PERSONAL INJURY, OR SEVERE PROPERTY OR ENVIRONMENTAL DAMAGE ("CRITICAL APPLICATIONS"). TI SEMICONDUCTOR PRODUCTS ARE NOT DESIGNED, AUTHORIZED, OR WARRANTED TO BE SUITABLE FOR USE IN LIFE-SUPPORT DEVICES OR SYSTEMS OR OTHER CRITICAL APPLICATIONS. INCLUSION OF TI PRODUCTS IN SUCH APPLICATIONS IS UNDERSTOOD TO BE FULLY AT THE CUSTOMER'S RISK.

In order to minimize risks associated with the customer's applications, adequate design and operating safeguards must be provided by the customer to minimize inherent or procedural hazards.

TI assumes no liability for applications assistance or customer product design. TI does not warrant or represent that any license, either express or implied, is granted under any patent right, copyright, mask work right, or other intellectual property right of TI covering or relating to any combination, machine, or process in which such semiconductor products or services might be or are used. TI's publication of information regarding any third party's products or services does not constitute TI's approval, warranty or endorsement thereof.