

SN54F241, SN74F241 OCTAL BUFFERS/DRIVERS WITH 3-STATE OUTPUTS

SDFS090 – MARCH 1987 – REVISED OCTOBER 1993

- 3-State Outputs Drive Bus Lines or Buffer Memory Address Registers
- Package Options Include Plastic Small-Outline Packages, Ceramic Chip Carriers, and Plastic and Ceramic DIPs

description

These octal buffers and line drivers are designed specifically to improve both the performance and density of 3-state memory address drivers, clock drivers, and bus-oriented receivers and transmitters. Taken together with the 'F240 and 'F244, these devices provide the choice of selected combinations of inverting and noninverting outputs, symmetrical \overline{OE} (active-low output-enable) inputs, and complementary OE and \overline{OE} inputs.

The SN54F241 is characterized for operation over the full military temperature range of -55°C to 125°C . The SN74F241 is characterized for operation from 0°C to 70°C .

SN54F241 . . . J PACKAGE
SN74F241 . . . DW OR N PACKAGE
(TOP VIEW)

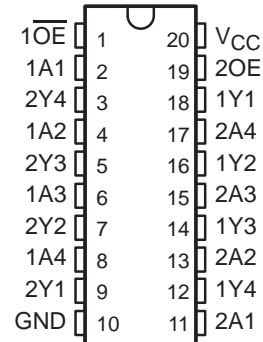

SN54F241 . . . FK PACKAGE
(TOP VIEW)

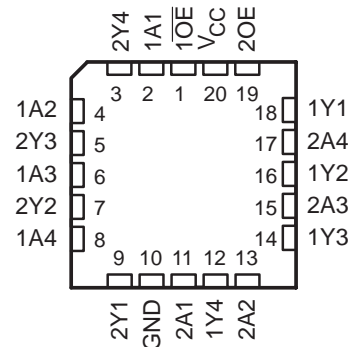

FUNCTION TABLES

INPUTS		OUTPUT
$\overline{1OE}$	1A	1Y
H	X	Z
L	H	H
L	L	L

INPUTS		OUTPUT
2OE	2A	2Y
H	H	H
H	L	L
L	X	Z

SN54F241, SN74F241 OCTAL BUFFERS/DRIVERS WITH 3-STATE OUTPUTS

SDFS090 – MARCH 1987 – REVISED OCTOBER 1993

logic symbol†

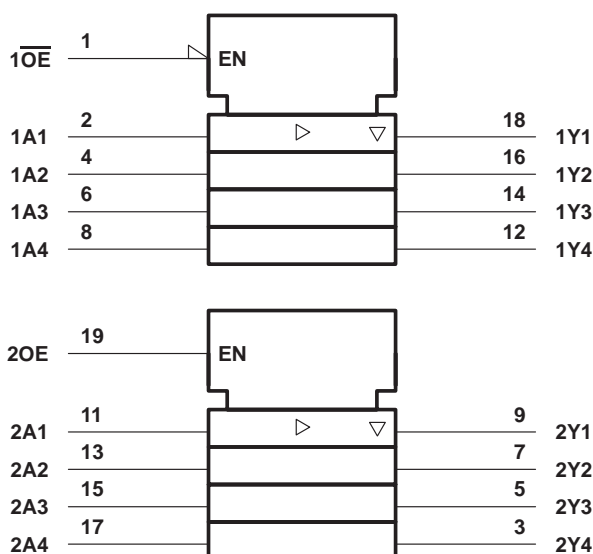

† This symbol is in accordance with ANSI/IEEE Std 91-1984 and IEC Publication 617-12.

logic diagram (positive logic)

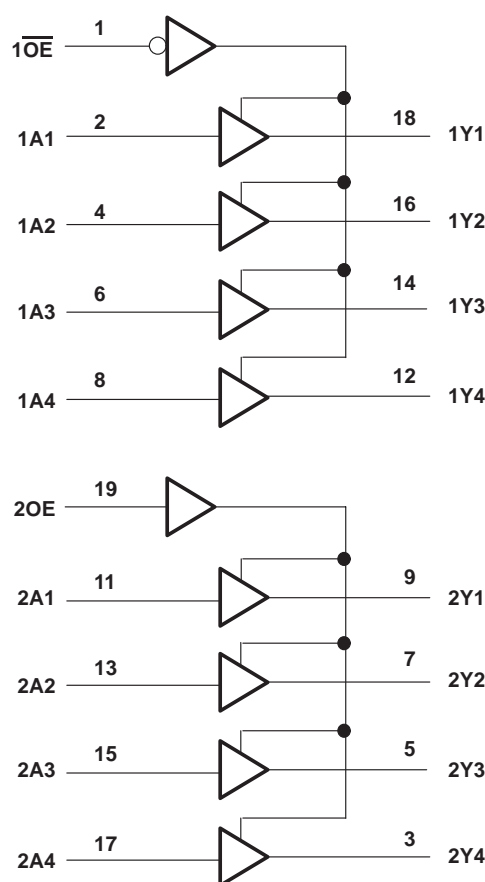

absolute maximum ratings over operating free-air temperature range (unless otherwise noted)‡

Supply voltage range, V_{CC}	-0.5 V to 7 V
Input voltage range, V_I (see Note 1)	-1.2 V to 7 V
Input current range	-30 mA to 5 mA
Voltage range applied to any output in the disabled or power-off state	-0.5 V to 5.5 V
Voltage range applied to any output in the high state	-0.5 V to V_{CC}
Current into any output in the low state: SN54F241	96 mA
SN74F241	128 mA
Operating free-air temperature range: SN54F241	-55°C to 125°C
SN74F241	0°C to 70°C
Storage temperature range	-65°C to 150°C

‡ Stresses beyond those listed under "absolute maximum ratings" may cause permanent damage to the device. These are stress ratings only and functional operation of the device at these or any other conditions beyond those indicated under "recommended operating conditions" is not implied. Exposure to absolute-maximum-rated conditions for extended periods may affect device reliability.

NOTE 1: The input voltage ratings may be exceeded provided the input current ratings are observed.

SN54F241, SN74F241 OCTAL BUFFERS/DRIVERS WITH 3-STATE OUTPUTS

SDFS090 – MARCH 1987 – REVISED OCTOBER 1993

recommended operating conditions

		SN54F241			SN74F241			UNIT
		MIN	NOM	MAX	MIN	NOM	MAX	
V_{CC}	Supply voltage	4.5	5	5.5	4.5	5	5.5	V
V_{IH}	High-level input voltage	2			2			V
V_{IL}	Low-level input voltage			0.8			0.8	V
I_{IK}	Input clamp current			-18			-18	mA
I_{OH}	High-level output current			-12			-15	mA
I_{OL}	Low-level output current			48			64	mA
T_A	Operating free-air temperature	-55		125	0		70	°C

electrical characteristics over recommended operating free-air temperature range (unless otherwise noted)

PARAMETER	TEST CONDITIONS		SN54F241		SN74F241		UNIT		
			MIN	TYP†	MAX	MIN		TYP†	MAX
V_{IK}	$V_{CC} = 4.5\text{ V}$,	$I_I = -18\text{ mA}$			-1.2		-1.2	V	
V_{OH}	$V_{CC} = 4.5\text{ V}$	$I_{OH} = -3\text{ mA}$	2.4	3.3	2.4	3.3	V		
		$I_{OH} = -12\text{ mA}$	2	3.2					
		$I_{OH} = -15\text{ mA}$			2	3.1			
	$V_{CC} = 4.75\text{ V}$,	$I_{OH} = -3\text{ mA}$			2.7				
V_{OL}	$V_{CC} = 4.5\text{ V}$	$I_{OL} = 48\text{ mA}$	0.38	0.55			V		
		$I_{OL} = 64\text{ mA}$			0.42	0.55			
I_{OZH}	$V_{CC} = 5.5\text{ V}$,	$V_O = 2.7\text{ V}$			50		50	μA	
I_{OZL}	$V_{CC} = 5.5\text{ V}$,	$V_O = 0.5\text{ V}$			-50		-50	μA	
I_I	$V_{CC} = 5.5\text{ V}$,	$V_I = 7\text{ V}$			0.1		0.1	mA	
I_{IH}	$V_{CC} = 5.5\text{ V}$,	$V_I = 2.7\text{ V}$			20		20	μA	
I_{IL}	OE or $\overline{\text{OE}}$	$V_{CC} = 5.5\text{ V}$,	$V_I = 0.5\text{ V}$			-1		-1	mA
	Any A					-1.6		-1.6	
I_{OS}^\ddagger	$V_{CC} = 5.5\text{ V}$,	$V_O = 0$	-100		-225	-100		-225	mA
I_{CC}	$V_{CC} = 5.5\text{ V}$	Outputs high	40	60	40	60	mA		
		Outputs low	60	90	60	90			
		Outputs disabled	60	90	60	90			

† All typical values are at $V_{CC} = 5\text{ V}$, $T_A = 25^\circ\text{C}$.

‡ Not more than one output should be shorted at a time, and the duration of the short circuit should not exceed one second.



SN54F241, SN74F241 OCTAL BUFFERS/DRIVERS WITH 3-STATE OUTPUTS

SDFS090 – MARCH 1987 – REVISED OCTOBER 1993

switching characteristics (see Note 2)

PARAMETER	FROM (INPUT)	TO (OUTPUT)	V _{CC} = 5 V, C _L = 50 pF, R _L = 500 Ω, T _A = 25°C			V _{CC} = 4.5 V to 5.5 V, C _L = 50 pF, R _L = 500 Ω, T _A = MIN to MAX†			UNIT	
			'F241			SN54F241		SN74F241		
			MIN	TYP	MAX	MIN	MAX	MIN		MAX
t _{PLH}	Any A	Y	1.7	3.6	5.2	1.2	6.5	1.7	6.2	ns
t _{PHL}			1.7	3.6	5.2	1.2	7	1.7	6.5	
t _{PZH}	$\overline{\text{OE}}$ or OE	Y	1.2	3.9	5.7	1.2	7	1.2	6.7	ns
t _{PZL}			1.2	5	7	1.2	8.5	1.2	8	
t _{PHZ}	$\overline{\text{OE}}$ or OE	Y	1.2	4.1	6	1.2	7	1.2	7	ns
t _{PLZ}			1.2	4.1	6	1.2	7.5	1.2	7	

† For conditions shown as MIN or MAX, use the appropriate value specified under recommended operating conditions.

NOTE 2: Load circuits and waveforms are shown in Section 1.



IMPORTANT NOTICE

Texas Instruments and its subsidiaries (TI) reserve the right to make changes to their products or to discontinue any product or service without notice, and advise customers to obtain the latest version of relevant information to verify, before placing orders, that information being relied on is current and complete. All products are sold subject to the terms and conditions of sale supplied at the time of order acknowledgement, including those pertaining to warranty, patent infringement, and limitation of liability.

TI warrants performance of its semiconductor products to the specifications applicable at the time of sale in accordance with TI's standard warranty. Testing and other quality control techniques are utilized to the extent TI deems necessary to support this warranty. Specific testing of all parameters of each device is not necessarily performed, except those mandated by government requirements.

CERTAIN APPLICATIONS USING SEMICONDUCTOR PRODUCTS MAY INVOLVE POTENTIAL RISKS OF DEATH, PERSONAL INJURY, OR SEVERE PROPERTY OR ENVIRONMENTAL DAMAGE ("CRITICAL APPLICATIONS"). TI SEMICONDUCTOR PRODUCTS ARE NOT DESIGNED, AUTHORIZED, OR WARRANTED TO BE SUITABLE FOR USE IN LIFE-SUPPORT DEVICES OR SYSTEMS OR OTHER CRITICAL APPLICATIONS. INCLUSION OF TI PRODUCTS IN SUCH APPLICATIONS IS UNDERSTOOD TO BE FULLY AT THE CUSTOMER'S RISK.

In order to minimize risks associated with the customer's applications, adequate design and operating safeguards must be provided by the customer to minimize inherent or procedural hazards.

TI assumes no liability for applications assistance or customer product design. TI does not warrant or represent that any license, either express or implied, is granted under any patent right, copyright, mask work right, or other intellectual property right of TI covering or relating to any combination, machine, or process in which such semiconductor products or services might be or are used. TI's publication of information regarding any third party's products or services does not constitute TI's approval, warranty or endorsement thereof.