

# SN54HC540, SN74HC540 OCTAL BUFFERS AND LINE DRIVERS WITH 3-STATE OUTPUTS

SCLS007B – MARCH 1984 – REVISED MAY 1997

- High-Current 3-State Outputs Drive Bus Lines Directly or up to 15 LSTTL Loads
- Data Flow-Through Pinout (All Inputs on Opposite Side From Outputs)
- Package Options Include Plastic (DW) and Ceramic Flat (W) Packages, Ceramic Chip Carriers (FK), and Standard Plastic (N) and Ceramic (J) 300-mil DIPs

## description

These octal buffers and line drivers feature the performance of the popular 'HC240 series and offer a pinout with inputs and outputs on opposite sides of the package. This arrangement greatly enhances printed circuit board layout.

The 3-state control gate is a 2-input NOR. If either output-enable ( $\overline{OE1}$  or  $\overline{OE2}$ ) input is high, all eight outputs are in the high-impedance state. The 'HC540 provide inverted data at the outputs.

The SN54HC540 is characterized for operation over the full military temperature range of  $-55^{\circ}\text{C}$  to  $125^{\circ}\text{C}$ . The SN74HC540 is characterized for operation from  $-40^{\circ}\text{C}$  to  $85^{\circ}\text{C}$ .

SN54HC540 . . . J OR W PACKAGE  
SN74HC540 . . . DW OR N PACKAGE  
(TOP VIEW)

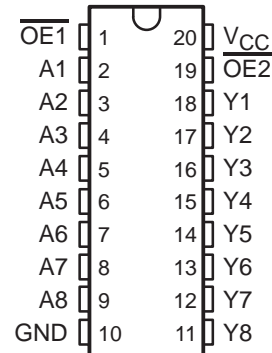

SN54HC540 . . . FK PACKAGE  
(TOP VIEW)

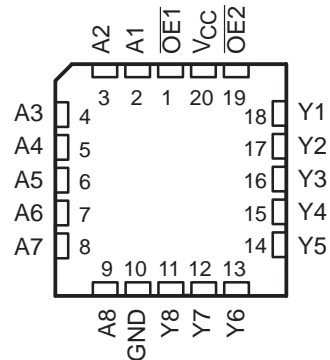

FUNCTION TABLE  
(each buffer/driver)

INPUTS			OUTPUT
$\overline{OE1}$	$\overline{OE2}$	A	Y
L	L	L	H
L	L	H	L
H	X	X	Z
X	H	X	Z



Please be aware that an important notice concerning availability, standard warranty, and use in critical applications of Texas Instruments semiconductor products and disclaimers thereto appears at the end of this data sheet.

PRODUCTION DATA information is current as of publication date. Products conform to specifications per the terms of Texas Instruments standard warranty. Production processing does not necessarily include testing of all parameters.

 **TEXAS  
INSTRUMENTS**

POST OFFICE BOX 655303 • DALLAS, TEXAS 75265

Copyright © 1997, Texas Instruments Incorporated



**SN54HC540, SN74HC540**  
**OCTAL BUFFERS AND LINE DRIVERS**  
**WITH 3-STATE OUTPUTS**

SCLS007B – MARCH 1984 – REVISED MAY 1997

**recommended operating conditions**

		SN54HC540			SN74HC540			UNIT
		MIN	NOM	MAX	MIN	NOM	MAX	
V <sub>CC</sub>	Supply voltage	2	5	6	2	5	6	V
V <sub>IH</sub>	High-level input voltage	V <sub>CC</sub> = 2 V		1.5	1.5		V	
		V <sub>CC</sub> = 4.5 V		3.15	3.15			
		V <sub>CC</sub> = 6 V		4.2	4.2			
V <sub>IL</sub>	Low-level input voltage	V <sub>CC</sub> = 2 V		0	0.5	0	0.5	V
		V <sub>CC</sub> = 4.5 V		0	1.35	0	1.35	
		V <sub>CC</sub> = 6 V		0	1.8	0	1.8	
V <sub>I</sub>	Input voltage	0		V <sub>CC</sub>	0		V <sub>CC</sub>	V
V <sub>O</sub>	Output voltage	0		V <sub>CC</sub>	0		V <sub>CC</sub>	V
t <sub>t</sub>	Input transition (rise and fall) time	V <sub>CC</sub> = 2 V		0	1000	0	1000	ns
		V <sub>CC</sub> = 4.5 V		0	500	0	500	
		V <sub>CC</sub> = 6 V		0	400	0	400	
T <sub>A</sub>	Operating free-air temperature	-55		125	-40		85	°C

**electrical characteristics over recommended operating free-air temperature range (unless otherwise noted)**

PARAMETER	TEST CONDITIONS		V <sub>CC</sub>	T <sub>A</sub> = 25°C			SN54HC540		SN74HC540		UNIT
				MIN	TYP	MAX	MIN	MAX	MIN	MAX	
V <sub>OH</sub>	V <sub>I</sub> = V <sub>IH</sub> or V <sub>IL</sub>	I <sub>OH</sub> = -20 μA	2 V	1.9	1.998		1.9		1.9	V	
			4.5 V	4.4	4.499		4.4		4.4		
			6 V	5.9	5.999		5.9		5.9		
		I <sub>OH</sub> = -6 mA	4.5 V	3.98	4.3		3.7		3.84		
		I <sub>OH</sub> = -7.8 mA	6 V	5.48	5.8		5.2		5.34		
V <sub>OL</sub>	V <sub>I</sub> = V <sub>IH</sub> or V <sub>IL</sub>	I <sub>OL</sub> = 20 μA	2 V		0.002	0.1		0.1		V	
			4.5 V		0.001	0.1		0.1			0.1
			6 V		0.001	0.1		0.1			0.1
		I <sub>OL</sub> = 6 mA	4.5 V		0.17	0.26		0.4			0.33
		I <sub>OL</sub> = 7.8 mA	6 V		0.15	0.26		0.4			0.33
I <sub>I</sub>	V <sub>I</sub> = V <sub>CC</sub> or 0		6 V		±0.1	±100		±1000		±1000	nA
I <sub>OZ</sub>	V <sub>O</sub> = V <sub>CC</sub> or 0		6 V		±0.01	±0.5		±10		±5	μA
I <sub>CC</sub>	V <sub>I</sub> = V <sub>CC</sub> or 0, I <sub>O</sub> = 0		6 V			8		160		80	μA
C <sub>i</sub>			2 V to 6 V		3	10		10		10	pF



**SN54HC540, SN74HC540**  
**OCTAL BUFFERS AND LINE DRIVERS**  
**WITH 3-STATE OUTPUTS**

SCLS007B – MARCH 1984 – REVISED MAY 1997

switching characteristics over recommended operating free-air temperature range,  $C_L = 50 \text{ pF}$  (unless otherwise noted) (see Figure 1)

PARAMETER	FROM (INPUT)	TO (OUTPUT)	$V_{CC}$	$T_A = 25^\circ\text{C}$			SN54HC540		SN74HC540		UNIT
				MIN	TYP	MAX	MIN	MAX	MIN	MAX	
$t_{pd}$	A	Y	2 V		35	100		149		125	ns
			4.5 V		10	20		30		25	
			6 V		8	17		25		21	
$t_{en}$	$\overline{OE}$	Y	2 V		75	150		224		188	ns
			4.5 V		15	30		45		38	
			6 V		13	26		38		32	
$t_{dis}$	$\overline{OE}$	Y	2 V		40	150		224		188	ns
			4.5 V		18	30		45		38	
			6 V		17	26		38		32	
$t_t$		Y	2 V		28	60		90		75	ns
			4.5 V		8	12		18		15	
			6 V		6	10		15		13	

switching characteristics over recommended operating free-air temperature range,  $C_L = 150 \text{ pF}$  (unless otherwise noted) (see Figure 1)

PARAMETER	FROM (INPUT)	TO (OUTPUT)	$V_{CC}$	$T_A = 25^\circ\text{C}$			SN54HC540		SN74HC540		UNIT
				MIN	TYP	MAX	MIN	MAX	MIN	MAX	
$t_{pd}$	A	Y	2 V		60	150		224		188	ns
			4.5 V		15	30		45		38	
			6 V		13	26		38		32	
$t_{en}$	$\overline{OE}$	Y	2 V		100	200		298		250	ns
			4.5 V		20	40		60		50	
			6 V		17	34		51		43	
$t_t$		Y	2 V		45	210		315		265	ns
			4.5 V		17	42		63		53	
			6 V		13	36		53		45	

operating characteristics,  $T_A = 25^\circ\text{C}$

PARAMETER	TEST CONDITIONS	TYP	UNIT
$C_{pd}$ Power dissipation capacitance per buffer/driver	No load	35	pF



PARAMETER MEASUREMENT INFORMATION

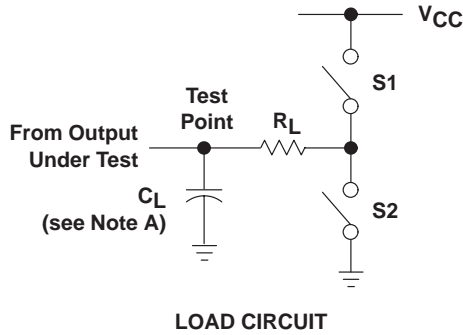

PARAMETER	$R_L$	$C_L$	S1	S2
$t_{en}$	1 k $\Omega$	50 pF or 150 pF	Open	Closed
			Closed	Open
$t_{dis}$	1 k $\Omega$	50 pF	Open	Closed
			Closed	Open
$t_{pd}$ or $t_t$	—	50 pF or 150 pF	Open	Open

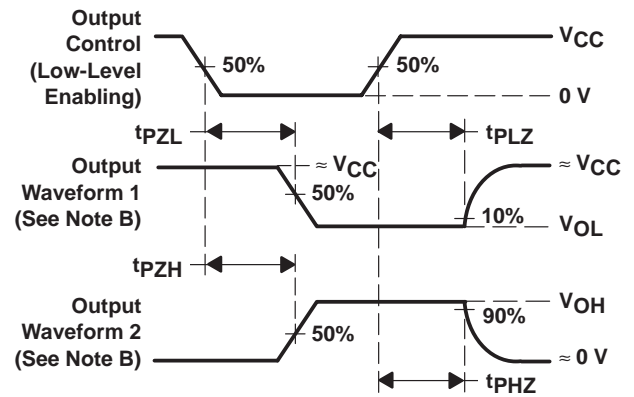
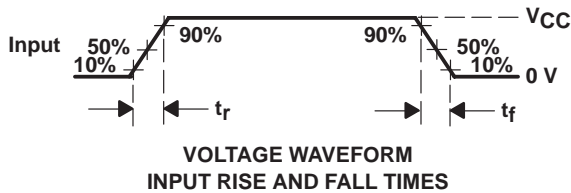
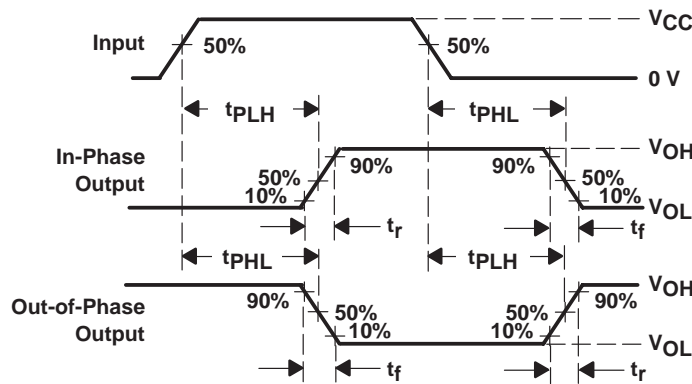

- NOTES:
- A.  $C_L$  includes probe and test-fixture capacitance.
  - B. Waveform 1 is for an output with internal conditions such that the output is low except when disabled by the output control. Waveform 2 is for an output with internal conditions such that the output is high except when disabled by the output control.
  - C. Phase relationships between waveforms were chosen arbitrarily. All input pulses are supplied by generators having the following characteristics: PRR  $\leq$  1 MHz,  $Z_O = 50 \Omega$ ,  $t_r = 6$  ns,  $t_f = 6$  ns.
  - D. The outputs are measured one at a time with one input transition per measurement.
  - E.  $t_{PLZ}$  and  $t_{PHZ}$  are the same as  $t_{dis}$ .
  - F.  $t_{PZL}$  and  $t_{PZH}$  are the same as  $t_{en}$ .
  - G.  $t_{PLH}$  and  $t_{PHL}$  are the same as  $t_{pd}$ .

Figure 1. Load Circuit and Voltage Waveforms

## IMPORTANT NOTICE

Texas Instruments and its subsidiaries (TI) reserve the right to make changes to their products or to discontinue any product or service without notice, and advise customers to obtain the latest version of relevant information to verify, before placing orders, that information being relied on is current and complete. All products are sold subject to the terms and conditions of sale supplied at the time of order acknowledgement, including those pertaining to warranty, patent infringement, and limitation of liability.

TI warrants performance of its semiconductor products to the specifications applicable at the time of sale in accordance with TI's standard warranty. Testing and other quality control techniques are utilized to the extent TI deems necessary to support this warranty. Specific testing of all parameters of each device is not necessarily performed, except those mandated by government requirements.

CERTAIN APPLICATIONS USING SEMICONDUCTOR PRODUCTS MAY INVOLVE POTENTIAL RISKS OF DEATH, PERSONAL INJURY, OR SEVERE PROPERTY OR ENVIRONMENTAL DAMAGE ("CRITICAL APPLICATIONS"). TI SEMICONDUCTOR PRODUCTS ARE NOT DESIGNED, AUTHORIZED, OR WARRANTED TO BE SUITABLE FOR USE IN LIFE-SUPPORT DEVICES OR SYSTEMS OR OTHER CRITICAL APPLICATIONS. INCLUSION OF TI PRODUCTS IN SUCH APPLICATIONS IS UNDERSTOOD TO BE FULLY AT THE CUSTOMER'S RISK.

In order to minimize risks associated with the customer's applications, adequate design and operating safeguards must be provided by the customer to minimize inherent or procedural hazards.

TI assumes no liability for applications assistance or customer product design. TI does not warrant or represent that any license, either express or implied, is granted under any patent right, copyright, mask work right, or other intellectual property right of TI covering or relating to any combination, machine, or process in which such semiconductor products or services might be or are used. TI's publication of information regarding any third party's products or services does not constitute TI's approval, warranty or endorsement thereof.