



SCCS025 - May 1993 - Revised March 2000

CY54/74FCT480T

Dual 8-Bit Parity Generator/Checker

Features

- Function, pinout and drive compatible with FCT and F logic
- FCT-A speed at 7.5 ns max. (Com'l)
FCT-B speed at 5.6 ns max. (Com'l)
- Reduced V_{OH} (typically = 3.3V) versions of equivalent FCT functions
- Edge-rate control circuitry for significantly improved noise characteristics
- Power-off disable feature
- Matched rise and fall times
- ESD > 2000V
- Fully compatible with TTL input and output logic levels
- Sink Current **64 mA (Com'l),**
 32 mA (Mil)
- Source Current **32 mA (Com'l),**
 12 mA (Mil)

- Two 8-bit parity generator/checkers
- Open drain Active LOW parity error output
- Expandable for larger word widths

Functional Description

The FCT480T is a high-speed dual 8-bit parity generator/checker. Each parity generator/checker accepts eight data bits and one parity bit as inputs, and generates a sum and parity error output. The FCT480T can be used in ODD parity systems. The parity error output is open-drain, designed for easy expansion of the word width by a wired-OR connection of several FCT480T type devices. Since additional logic is not needed, the parity generation or checking times remain the same as for an individual FCT480T device.

The outputs are designed with a power-off disable feature to allow for live insertion of boards.

Logic Block Diagram

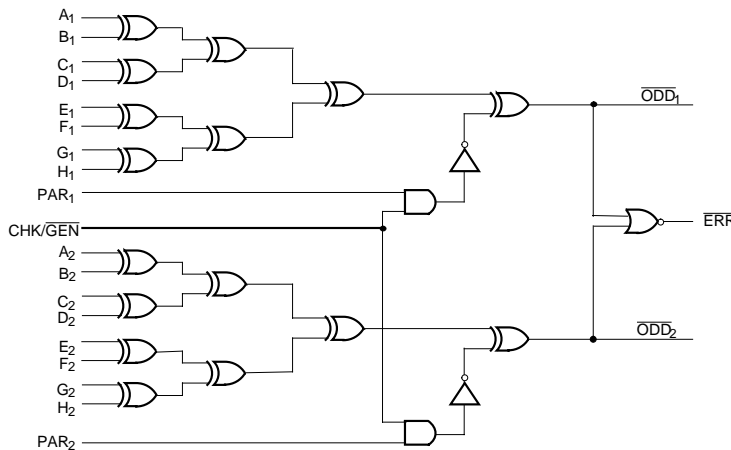

FCT480T-1

Pin Configurations

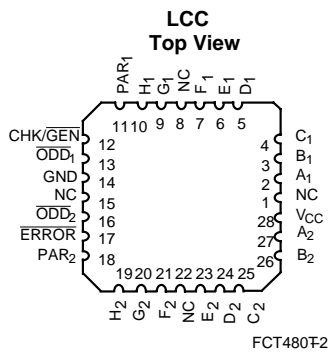

FCT480F2

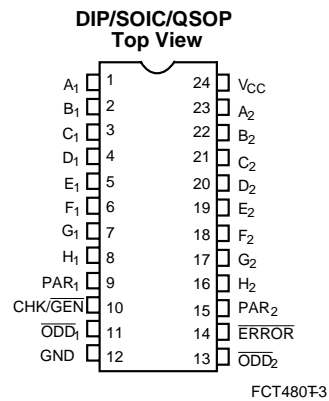

FCT480F3

Function Table

Inputs					Outputs				
A ₁ to H ₁	A ₂ to H ₂	CHK/GEN	PAR ₁	PAR ₂	ODD ₁	ODD ₂	ERROR		
Number of A ₁ to H ₁ Inputs HIGH is EVEN	Number of A ₂ to H ₂ Inputs HIGH is EVEN	H	H	H	L	L	H		
			L	H	H	L	L		
			H	L	L	H	L		
			L	L	H	H	L		
	Number of Inputs HIGH A ₂ to H ₂ is ODD	H	H	X	X	H	H	L	
				H	H	L	H	L	
				L	H	H	H	L	
				H	L	L	L	H	
			L	X	X	H	L	L	
						L	L	H	L
Number of A ₁ to H ₁ Inputs HIGH is ODD	Number of A ₂ to H ₂ Inputs HIGH is EVEN	H	H	H	H	L	L		
			L	H	L	L	H		
			H	L	H	H	L		
			L	L	L	H	L		
	Number of A ₂ to H ₂ Inputs HIGH is ODD	H	L	X	X	L	H	L	
				H	H	H	H	L	
				L	H	L	H	L	
				H	L	H	L	L	
			L	X	X	L	L	L	H
						L	L	L	L

Maximum Ratings^[1, 2]

(Above which the useful life may be impaired. For user guidelines, not tested.)

Storage Temperature	-65°C to +150°C
Ambient Temperature with Power Applied	-65°C to +135°C
Supply Voltage to Ground Potential	-0.5V to +7.0V
DC Input Voltage	-0.5V to +7.0V
DC Output Voltage	-0.5V to +7.0V
DC Output Current (Maximum Sink Current/Pin)	120 mA
Power Dissipation	0.5W

Static Discharge Voltage.....>2001V
(per MIL-STD-883, Method 3015)

Operating Range

Range	Range	Ambient Temperature	V _{CC}
Commercial	All	-40°C to +85°C	5V ± 5%
Military ^[3]	All	-55°C to +125°C	5V ± 10%

Notes:

1. Unless otherwise noted, these limits are over the operating free-air temperature range.
2. Unused inputs must always be connected to an appropriate logic voltage level, preferably either V_{CC} or ground.
3. T_A is the "instant on" case temperature.

Electrical Characteristics Over the Operating Range

Parameter	Description	Test Conditions		Min.	Typ. ^[4]	Max.	Unit
V _{OH}	Output HIGH Voltage	V _{CC} = Min., I _{OH} = -32 mA	Com'l	2.0			V
		V _{CC} = Min., I _{OH} = -15 mA	Com'l	2.4	3.3		V
		V _{CC} = Min., I _{OH} = -12 mA	Mil	2.4	3.3		V
V _{OL}	Output LOW Voltage	V _{CC} = Min., I _{OL} = 64 mA	Com'l		0.3	0.55	V
		V _{CC} = Min., I _{OL} = 32 mA	Mil		0.3	0.55	V
V _{IH}	Input HIGH Voltage			2.0			V
V _{IL}	Input LOW Voltage					0.8	V
V _H	Hysteresis ^[5]	All inputs			0.2		V
V _{IK}	Input Clamp Diode Voltage	V _{CC} = Min., I _{IN} = -18 mA			-0.7	-1.2	V
I _I	Input HIGH Current	V _{CC} = Max., V _{IN} = V _{CC}				5	μA
I _{IH}	Input HIGH Current	V _{CC} = Max., V _{IN} = 2.7V				±1	μA
I _{IL}	Input LOW Current	V _{CC} = Max., V _{IN} = 0.5V				±1	μA
I _{OZH}	Off State HIGH-Level Output Current	V _{CC} = Max., V _{OUT} = 2.7V				10	μA
I _{OZL}	Off State LOW-Level Output Current	V _{CC} = Max., V _{OUT} = 0.5V				-10	μA
I _{OS}	Output Short Circuit Current ^[6]	V _{CC} = Max., V _{OUT} = 0.0V		-60	-120	-225	mA
I _{OFF}	Power-Off Disable	V _{CC} = 0V, V _{OUT} = 4.5V				±1	μA

Capacitance^[5]

Parameter	Description	Typ. ^[4]	Max.	Unit
C _{IN}	Input Capacitance	5	10	pF
C _{OUT}	Output Capacitance	9	12	pF

Notes:

4. Typical values are at V_{CC}=5.0V, T_A=+25°C ambient.
5. This parameter is specified but not tested.
6. Not more than one output should be shorted at a time. Duration of short should not exceed one second. The use of high-speed test apparatus and/or sample and hold techniques are preferable in order to minimize internal chip heating and more accurately reflect operational values. Otherwise prolonged shorting of a high output may raise the chip temperature well above normal and thereby cause invalid readings in other parametric tests. In any sequence of parameter tests, I_{OS} tests should be performed last.

Power Supply Characteristics

Parameter	Description	Test Conditions	Typ. ^[4]	Max.	Unit
I_{CC}	Quiescent Power Supply Current	$V_{CC}=\text{Max.}, V_{IN} \leq 0.2V,$ $V_{IN} \geq V_{CC}-0.2V$	0.1	0.2	mA
ΔI_{CC}	Quiescent Power Supply Current (TTL inputs HIGH)	$V_{CC}=\text{Max.}, V_{IN}=3.4V,$ ^[7] $f_1=0,$ Outputs Open	0.5	2.0	mA
I_{CCD}	Dynamic Power Supply Current ^[8]	$V_{CC}=\text{Max.},$ One Bit Toggling, 50% Duty Cycle, Outputs Open, $V_{IN} \leq 0.2V$ or $V_{IN} \geq V_{CC}-0.2V$	0.06	0.12	mA/ MHz
I_C	Total Power Supply Current ^[9]	$V_{CC}=\text{Max.},$ 50% Duty Cycle, Outputs Open, One Bit Toggling at $f_1=2.5$ MHz, $V_{IN} \leq 0.2V$ or $V_{IN} \geq V_{CC}-0.2V$	0.7	1.4	mA
		$V_{CC}=\text{Max.},$ 50% Duty Cycle, Outputs Open, One Bit Toggling at $f_1=2.5$ MHz, $V_{IN}=3.4V$ or $V_{IN}=\text{GND}$	1.0	2.4	mA
		$V_{CC}=\text{Max.},$ 50% Duty Cycle, Outputs Open, Sixteen Bits Toggling at $f_1=2.5$ MHz, $V_{IN} \leq 0.2V$ or $V_{IN} \geq V_{CC}-0.2V$	2.5	5.0 ^[10]	mA
		$V_{CC}=\text{Max.},$ 50% Duty Cycle, Outputs Open, Sixteen Bits Toggling at $f_1=2.5$ MHz, $V_{IN}=3.4V$ or $V_{IN}=\text{GND}$	6.5	21.0 ^[10]	mA

Switching Characteristics Over the Operating Range

	Description	FCT480AT	FCT480BT		Unit
		Com'l	Military	Com'l	
t_{PLH} t_{PHL}	Propagation Delay A to EVEN/ODD	7.5 7.0	7.0 6.6	5.6 5.6	ns
t_{PLH} ^[11] t_{PHL}	Propagation Delay A to ERROR	7.0 8.5	7.0 8.1	5.6 6.5	ns
t_{PLH} t_{PHL}	Propagation Delay CHK/GEN to EVEN/ODD	6.5 7.5	6.3 7.4	5.9 5.9	ns
t_{PLH} ^[11] t_{PHL}	Propagation Delay CHK/GEN to ERROR	7.5 7.0	7.1 6.9	5.7 5.5	ns

Notes:

7. Per TTL driven input ($V_{IN}=3.4V$); all other inputs at V_{CC} or GND.
8. This parameter is not directly testable, but is derived for use in Total Power Supply calculations.
9. $I_C = I_{\text{QUIESCENT}} + I_{\text{INPUTS}} + I_{\text{DYNAMIC}}$
 $I_C = I_{CC} + \Delta I_{CC} D_H N_T + I_{CCD} (f_0/2 + f_1 N_1)$
 I_{CC} = Quiescent Current with CMOS input levels
 ΔI_{CC} = Power Supply Current for a TTL HIGH input ($V_{IN}=3.4V$)
 D_H = Duty Cycle for TTL inputs HIGH
 N_T = Number of TTL inputs at D_H
 I_{CCD} = Dynamic Current caused by an input transition pair (HLH or LHL)
 f_0 = Clock frequency for registered devices, otherwise zero
 f_1 = Input signal frequency
 N_1 = Number of inputs changing at f_1
 All currents are in milliamps and all frequencies are in megahertz.
10. Values for these conditions are examples of the I_{CC} formula. These limits are specified but not tested.
11. t_{PLH} is measured up to $V_{OUT}=V_{OL}+0.3V$

Ordering Information

Speed (ns)	Ordering Code	Package Name	Package Type	Operating Range
5.6	CY74FCT480BTPC	P13/13A	24-Lead (300-Mil) Molded DIP	Commercial
	CY74FCT480BTQCT	Q13	24-Lead (150-Mil) QSOP	
	CY74FCT480BTSOC/SOCT	S13	24-Lead (300-Mil) Molded SOIC	
7.0	CY54FCT480BTLMB	L64	28-Square Leadless Chip Carrier	Military
7.5	CY74FCT480ATPC	P13/13A	24-Lead (300-Mil) Molded DIP	Commercial
	CY74FCT480ATQCT	Q13	24-Lead (150-Mil) QSOP	

Document #: 38-00281-B

Package Diagrams

**28-Square Leadless Chip Carrier L64
MIL-STD-1835 C-4**

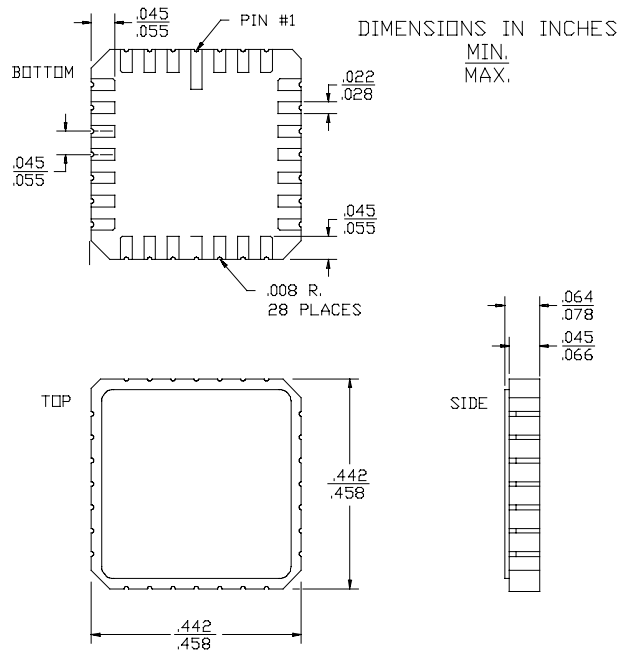

24-Lead (300-Mil) Molded DIP P13/P13A

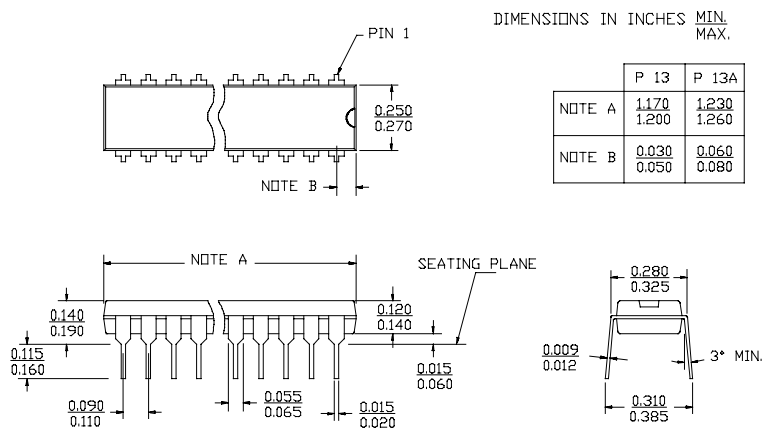

Package Diagrams (continued)

24-Lead Quarter Size Outline Q13

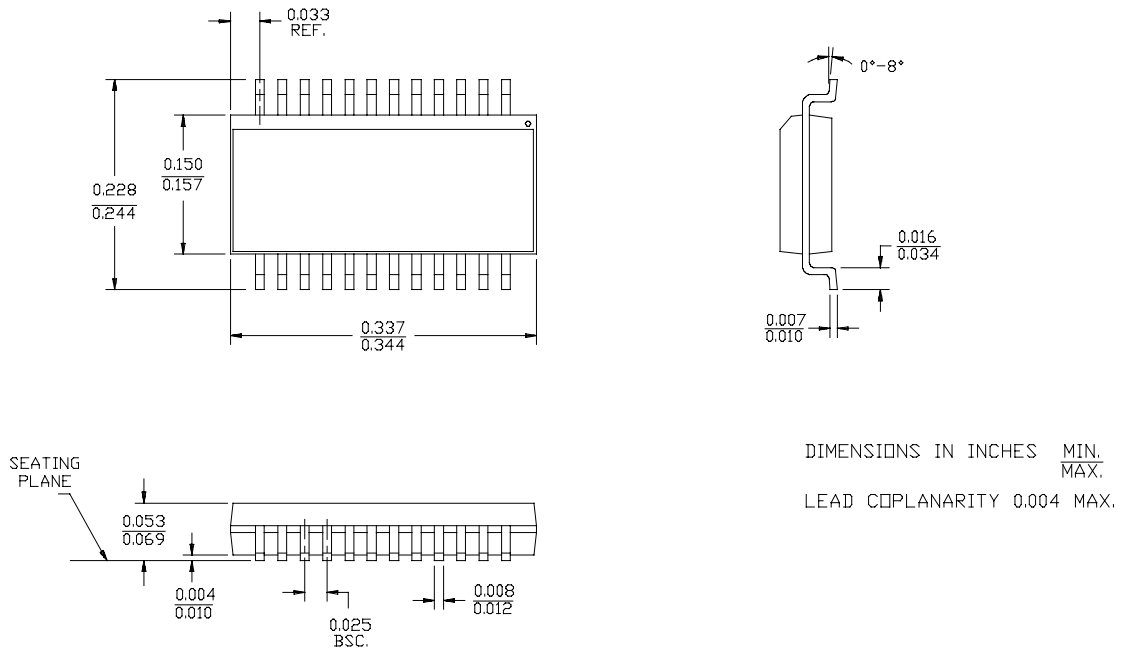

24-Lead (300-Mil) Molded SOIC S13

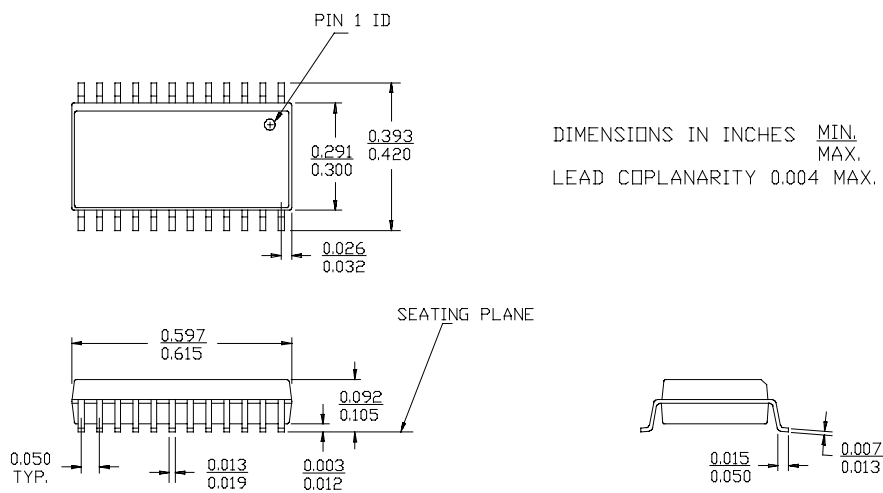

IMPORTANT NOTICE

Texas Instruments and its subsidiaries (TI) reserve the right to make changes to their products or to discontinue any product or service without notice, and advise customers to obtain the latest version of relevant information to verify, before placing orders, that information being relied on is current and complete. All products are sold subject to the terms and conditions of sale supplied at the time of order acknowledgement, including those pertaining to warranty, patent infringement, and limitation of liability.

TI warrants performance of its semiconductor products to the specifications applicable at the time of sale in accordance with TI's standard warranty. Testing and other quality control techniques are utilized to the extent TI deems necessary to support this warranty. Specific testing of all parameters of each device is not necessarily performed, except those mandated by government requirements.

CERTAIN APPLICATIONS USING SEMICONDUCTOR PRODUCTS MAY INVOLVE POTENTIAL RISKS OF DEATH, PERSONAL INJURY, OR SEVERE PROPERTY OR ENVIRONMENTAL DAMAGE ("CRITICAL APPLICATIONS"). TI SEMICONDUCTOR PRODUCTS ARE NOT DESIGNED, AUTHORIZED, OR WARRANTED TO BE SUITABLE FOR USE IN LIFE-SUPPORT DEVICES OR SYSTEMS OR OTHER CRITICAL APPLICATIONS. INCLUSION OF TI PRODUCTS IN SUCH APPLICATIONS IS UNDERSTOOD TO BE FULLY AT THE CUSTOMER'S RISK.

In order to minimize risks associated with the customer's applications, adequate design and operating safeguards must be provided by the customer to minimize inherent or procedural hazards.

TI assumes no liability for applications assistance or customer product design. TI does not warrant or represent that any license, either express or implied, is granted under any patent right, copyright, mask work right, or other intellectual property right of TI covering or relating to any combination, machine, or process in which such semiconductor products or services might be or are used. TI's publication of information regarding any third party's products or services does not constitute TI's approval, warranty or endorsement thereof.