

16-Bit Registered Transceivers

Features

- **FCT-E speed at 3.8 ns**
- **Power-off disable outputs permits live insertion**
- **Edge-rate control circuitry for significantly improved noise characteristics**
- **Typical output skew < 250 ps**
- **ESD > 2000V**
- **TSSOP (19.6-mil pitch) and SSOP (25-mil pitch) packages**
- **Industrial temperature range of -40°C to +85°C**
- **V_{CC} = 5V ± 10%**

CY74FCT16652T Features:

- **64 mA sink current, 32 mA source current**
- **Typical V_{OLP} (ground bounce) < 1.0V at V_{CC} = 5V, T_A = 25°C**

CY74FCT162652T Features:

- **Balanced 24 mA output drivers**
- **Reduced system switching noise**
- **Typical V_{OLP} (ground bounce) < 0.6V at V_{CC} = 5V, T_A = 25°C**

Functional Description

These 16-bit, high-speed, low-power, registered transceivers that are organized as two independent 8-bit bus transceivers with three-state D-type registers and control circuitry arranged for multiplexed transmission of data directly from the input bus or from the internal storage registers. OEAB and OEBA control pins are provided to control the transceiver functions. SAB and SBA control pins are provided to select either real-time or stored data transfer.

Data on the A or B data bus, or both, can be stored in the internal D flip-flops by LOW-to-HIGH transitions at the appropriate clock pins (CLKAB or CLKBA), regardless of the select or enable control pins. When SAB and SBA are in the real-time transfer mode, it is also possible to store data without using the internal D-type flip-flops by simultaneously enabling OEAB and OEBA. In this configuration, each output reinforces its input. Thus, when all other data sources to the two sets of bus lines are at high impedance, each set of bus lines will remain at its last state. The output buffers are designed with a power-off disable feature that allows live insertion of boards.

The CY74FCT16652T is ideally suited for driving high-capacitance loads and low-impedance backplanes.

The CY74FCT162652T has 24-mA balanced output drivers with current-limiting resistors in the outputs. This reduces the need for external terminating resistors and provides for minimal undershoot and reduced ground bounce. The CY74FCT162652T is ideal for driving transmission lines.

Logic Block Diagrams

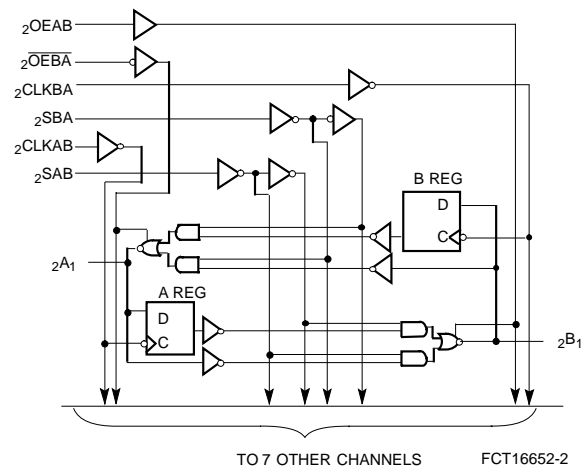
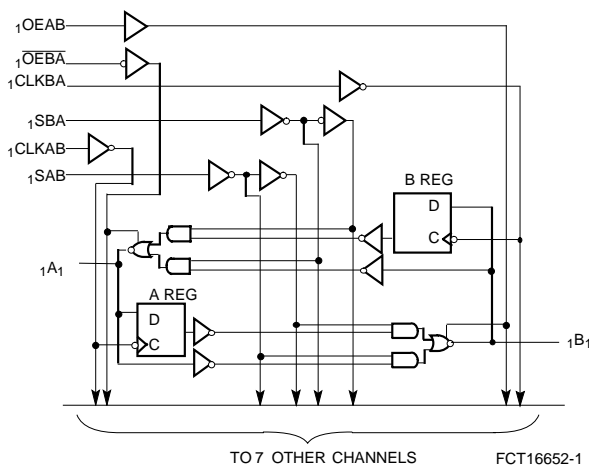

Pin Configuration

SSOP/TSSOP

Top View

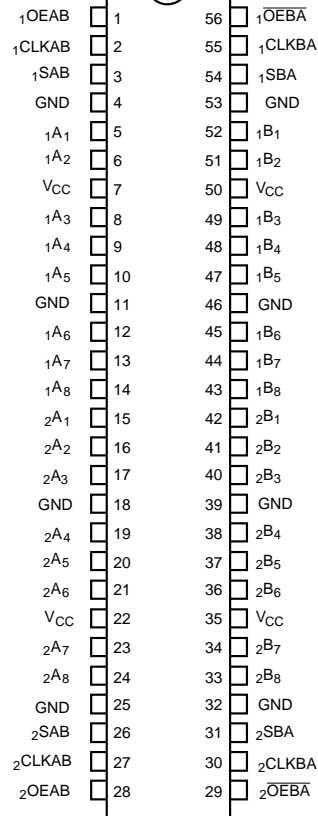

FCT16652-3

Pin Description

Name	Description
A	Data Register A Inputs Data Register B Outputs
B	Data Register B Inputs Data Register A Outputs
CLKAB, CLKBA	Clock Pulse Inputs
SAB, SBA	Output Data Source Select Inputs
OEAB, \overline{OEBA}	Output Enable Inputs

Function Table^[1]

Inputs						Data I/O ^[2]		Operation or Function
OEAB	\overline{OEBA}	CLKAB	CLKBA	SAB	SBA	A	B	
L L	H H	H or L ┐	H or L ┐	X X	X X	Input	Input	Isolation Store A and B Data
X H	H H	┐ ┐	H or L ┐	X X ^[3]	X X	Input Input	Unspecified ^[2] Output	Store A, Hold B Store A in Both Registers
L L	X L	H or L ┐	┐ ┐	X X	X X ^[3]	Unspecified ^[2]	Input Input	Hold A, Store B Store B in both Registers
L L	L L	X X	X H or L	X X	L H	Output	Input	Real Time B Data to A Bus Stored B Data to A Bus
H H	H H	X H or L	X X	L H	X X	Input	Output	Real Time A Data to B Bus Stored A Data to B Bus
H	L	H or L	H or L	H	H	Output	Output	Stored A Data to B Bus and Stored B Data to A Bus

Notes:

- H = HIGH Voltage Level
L = LOW Voltage Level
X = Don't Care
┐ = LOW-to-HIGH Transition
- The data output functions may be enabled or disabled by various signals at the OEAB or \overline{OEBA} inputs. Data input functions are always enabled, i.e., data at the bus pins will be stored on every LOW-to-HIGH transition on the clock inputs.
- Select control=L; clocks can occur simultaneously.
Select control=H; clocks must be staggered to load both registers.

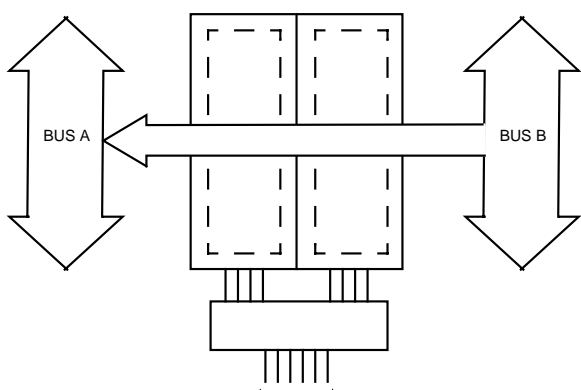

OEAB L OEBA L CLKAB X CLKBA X SAB X SBA L

Real-Time Transfer
Bus B to Bus A

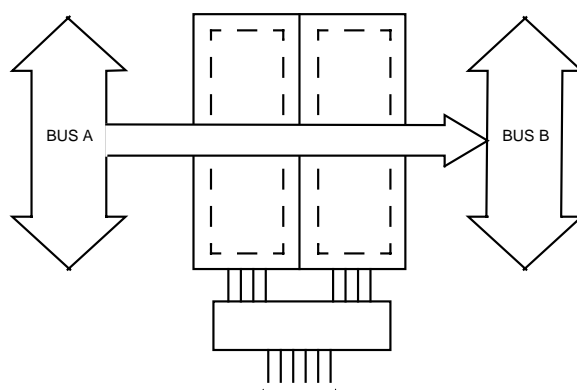

OEAB H OEBA L CLKAB X CLKBA X SAB L SBA X

Real-Time Transfer
Bus A to Bus B

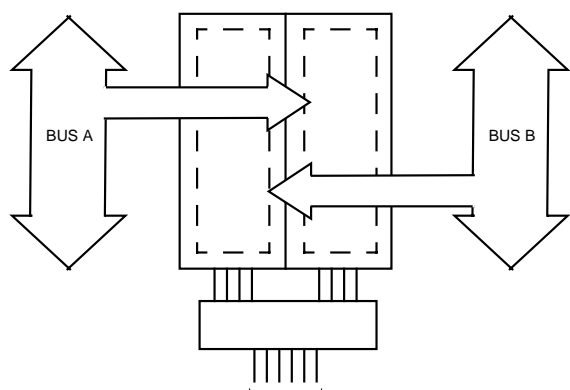

OEAB X OEBA H CLKAB L CLKBA X SAB X SBA X
L L X L X X
L H L L X X

Storage from
A and/or B

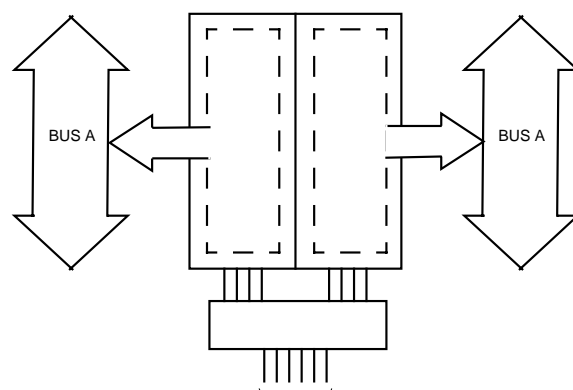

OEAB H OEBA L CLKAB H or L CLKBA H or L SAB H SBA H

Transfer Stored Data
to A and/or B

Maximum Ratings^[4]

(Above which the useful life may be impaired. For user guidelines, not tested.)

Storage TemperatureCom'l -55°C to +125°C

Ambient Temperature with
Power AppliedCom'l -55°C to +125°C

DC Input Voltage-0.5V to +7.0V

DC Output Voltage-0.5V to +7.0V

DC Output Current
(Maximum Sink Current/Pin)-60 to +120 mA

Power Dissipation 1.0W

Static Discharge Voltage.....>2001V
(per MIL-STD-883, Method 3015)

Operating Range

Range	Ambient Temperature	V _{CC}
Industrial	-40°C to +85°C	5V ± 10%

Note:

- Stresses greater than those listed under Maximum Ratings may cause permanent damage to the device. This is a stress rating only and functional operation of the device at these or any other conditions above those indicated in the operational sections of this specification is not implied. Exposure to absolute maximum rating conditions for extended periods may affect reliability.

DC Electrical Characteristics Over the Operating Range

Parameter	Description	Test Conditions ^[5]	Min.	Typ. ^[6]	Max.	Unit
V _{IH}	Input HIGH Voltage	Logic HIGH Level	2.0			V
V _{IL}	Input LOW Voltage	Logic LOW Level			0.8	V
V _H	Input Hysteresis			100		mV
V _{IK}	Input Clamp Diode Voltage	V _{CC} =Min., I _{IN} =-18 mA		-0.7	-1.2	V
I _{IH}	Input HIGH Current	V _{CC} =Max., V _I =V _{CC}			±1	μA
I _{IL}	Input LOW Current	V _{CC} =Max., V _I =GND			±1	μA
I _{OZH}	High Impedance Output Current (Three-State Output pins)	V _{CC} =Max., V _{OUT} =2.7V			±1	μA
I _{OZL}	High Impedance Output Current (Three-State Output pins)	V _{CC} =Max., V _{OUT} =0.5V			±1	μA
I _{OS}	Short Circuit Current ^[8]	V _{CC} =Max., V _{OUT} =GND	-80	-140	-200	mA
I _O	Output Drive Current ^[8]	V _{CC} =Max., V _{OUT} =2.5V	-50		-180	mA
I _{OFF}	Power-Off Disable	V _{CC} =0V, V _{OUT} ≤4.5V ^[7]			±1	μA

Output Drive Characteristics for CY74FCT16652T

Parameter	Description	Test Conditions ^[5]	Min.	Typ. ^[6]	Max.	Unit
V _{OH}	Output HIGH Voltage	V _{CC} =Min., I _{OH} =-3 mA	2.5	3.5		V
		V _{CC} =Min., I _{OH} =-15 mA	2.4	3.5		
		V _{CC} =Min., I _{OH} =-32 mA	2.0	3.0		
V _{OL}	Output LOW Voltage	V _{CC} =Min., I _{OL} =64 mA		0.2	0.55	V

Output Drive Characteristics for CY74FCT162652T

Parameter	Description	Test Conditions ^[5]	Min.	Typ. ^[6]	Max.	Unit
I _{ODL}	Output LOW Current ^[8]	V _{CC} =5V, V _{IN} =V _{IH} or V _{IL} , V _{OUT} =1.5V	60	115	150	mA
I _{ODH}	Output HIGH Current ^[8]	V _{CC} =5V, V _{IN} =V _{IH} or V _{IL} , V _{OUT} =1.5V	-60	-115	-150	mA
V _{OH}	Output HIGH Voltage	V _{CC} =Min., I _{OH} =-24 mA	2.4	3.3		V
V _{OL}	Output LOW Voltage	V _{CC} =Min., I _{OL} =24 mA		0.3	0.55	V

Capacitance (T_A = +25°C, f = 1.0 MHz)

Parameter	Description ^[10]	Test Conditions	Typ.	Max.	Unit
C _{IN}	Input Capacitance	V _{IN} = 0V	4.5	6.0	pF
C _{OUT}	Output Capacitance	V _{OUT} = 0V	5.5	8.0	pF

Notes:

5. For conditions shown as Max. or Min., use appropriate value specified under Electrical Characteristics for the applicable device type.
6. Typical values are at V_{CC}=5.0V, +25°C ambient.
7. Tested at T_A=+25°C.
8. Not more than one output should be tested at one time. Duration of the test should not exceed one second.
9. Duration of the condition cannot exceed one second.
10. This parameter is measured at characterization but not tested.

Power Supply Characteristics

Param.	Description	Test Conditions ^[11]		Min.	Typ. ^[12]	Max.	Unit
I _{CC}	Quiescent Power Supply Current	V _{CC} =Max.	V _{IN} ≤0.2V V _{IN} ≥V _{CC} -0.2V	—	5	500	μA
ΔI _{CC}	Quiescent Power Supply Current TTL Inputs HIGH	V _{CC} = Max. V _{IN} =3.4V ^[13]		—	0.5	1.5	mA
I _{CCD}	Dynamic Power Supply Current ^[14]	V _{CC} =Max. Outputs Open OEAB=OEBA=GND One Input Toggling 50% Duty Cycle	V _{IN} =V _{CC} or V _{IN} =GND	—	75	120	μA/ MHz
I _C	Total Power Supply Current ^[15]	V _{CC} =Max. Outputs Open f ₀ =10 MHz (CLKBA) 50% Duty Cycle OEAB=OEBA=GND One-Bit Toggling f ₁ =5 MHz 50% Duty Cycle	V _{IN} =V _{CC} or V _{IN} =GND	—	0.8	1.7	mA
			V _{IN} =3.4V or V _{IN} =GND	—	1.3	3.2	mA
		V _{CC} =Max. Outputs Open f ₀ =10 MHz (CLKBA) 50% Duty Cycle OEAB=OEBA=GND Sixteen Bits Toggling f ₁ =2.5 MHz 50% Duty Cycle	V _{IN} =V _{CC} or V _{IN} =GND	—	3.8	6.5 ^[16]	mA
			V _{IN} =3.4V or V _{IN} =GND	—	8.3	20.0 ^[16]	mA

Notes:

11. For conditions shown as Max. or Min., use appropriate value specified under Electrical Characteristics for the applicable device type.
12. Typical values are at V_{CC}=5.0V +25° ambient.
13. Per TTL driven input (V_{IN}=3.4V); all other inputs at V_{CC} or GND.
14. This parameter is not directly testable, but is derived for use in Total Power Supply calculations.
15. I_C = I_{QUIESCENT} + I_{INPUTS} + I_{DYNAMIC}
I_C = I_{CC} + ΔI_{CC}D_HN_T + I_{CCD}(f₀/2 + f₁N₁)
I_{CC} = Quiescent Current with CMOS input levels
ΔI_{CC} = Power Supply Current for a TTL HIGH input (V_{IN}=3.4V)
D_H = Duty Cycle for TTL inputs HIGH
N_T = Number of TTL inputs at D_H
I_{CCD} = Dynamic Current caused by an input transition pair (HLH or LHL)
f₀ = Clock frequency for registered devices, otherwise zero
f₁ = Input signal frequency
N₁ = Number of inputs changing at f₁
All currents are in milliamps and all frequencies are in megahertz.
16. Values for these conditions are examples of the I_{CC} formula. These limits are specified but not tested.

Switching Characteristics Over the Operating Range^[17]

Parameter	Description	CY74FCT16652AT CY74FCT162652AT		Unit	Fig. No. ^[18]
		Min.	Max.		
t _{PLH} t _{PHL}	Propagation Delay Bus to Bus	1.5	6.3	ns	1, 3
t _{PZH} t _{PHL}	Output Enable Time OEAB or OEBA to Bus	1.5	9.8	ns	1, 7, 8
t _{PHZ} t _{PLZ}	Output Disable Time OEAB or OEBA to Bus	1.5	6.3	ns	1, 7, 8
t _{PLH} t _{PHL}	Propagation Delay Clock to Bus	1.5	6.3	ns	1, 5
t _{PLH} t _{PHL}	Propagation Delay SBA or SAB to Bus	1.5	7.7	ns	1, 5
t _{SU}	Set-Up time HIGH or LOW Bus to Clock	2.0	—	ns	4
t _H	Hold Time HIGH or LOW Bus to Clock	1.5	—	ns	4
t _W	Clock Pulse Width HIGH or LOW	5.0	—	ns	5
t _{SK(O)}	Output Skew ^[19]	—	0.5	ns	

Parameter	Description	CY74FCT16652CT CY74FCT162652CT		CY74FCT16652ET CY74FCT162652ET		Unit	Fig. No. ^[18]
		Min.	Max.	Min.	Max.		
t _{PLH} t _{PHL}	Propagation Delay Bus to Bus	1.5	5.4	1.5	3.8	ns	1, 3
t _{PZH} t _{PHL}	Output Enable Time OEAB or OEBA to Bus	1.5	7.8	1.5	4.8	ns	1, 7, 8
t _{PHZ} t _{PLZ}	Output Disable Time OEAB or OEBA to Bus	1.5	6.3	1.5	4.0	ns	1, 7, 8
t _{PLH} t _{PHL}	Propagation Delay Clock to Bus	1.5	5.7	1.5	3.8	ns	1, 5
t _{PLH} t _{PHL}	Propagation Delay SBA or SAB to Bus	1.5	6.2	1.5	4.2	ns	1, 5
t _{SU}	Set-Up Time HIGH or LOW Bus to Clock	2.0	—	2.0	—	ns	4
t _H	Hold Time HIGH or LOW Bus to Clock	1.5	—	0.0	—	ns	4
t _W	Clock Pulse Width HIGH or LOW	5.0	—	3.0	—	ns	5
t _{SK(O)}	Output Skew ^[19]	—	0.5	—	0.5	ns	

Notes:

17. Minimum limits are specified, but not tested, on propagation delays.
18. See "Parameter Measurement Information" in the General Information section.
19. Skew between any two outputs of the same package switching in the same direction. This parameter ensured by design.

Ordering Information CY74FCT16652

Speed (ns)	Ordering Code	Package Name	Package Type	Operating Range
3.8	CY74FCT16652ETPACT	Z56	56-Lead (240-Mil) TSSOP	Industrial
	CY74FCT16652ETPVC/PVCT	O56	56-Lead (300-Mil) SSOP	
5.4	CY74FCT16652CTPVC/PVCT	O56	56-Lead (300-Mil) SSOP	Industrial
6.3	CY74FCT16652ATPVC/PVCT	O56	56-Lead (300-Mil) SSOP	Industrial

Ordering Information CY74FCT162652

Speed (ns)	Ordering Code	Package Name	Package Type	Operating Range
3.8	74FCT162652ETPACT	Z56	56-Lead (240-Mil) TSSOP	Industrial
	CY74FCT162652ETPVC	O56	56-Lead (300-Mil) SSOP	
	74FCT162652ETPVCT	O56	56-Lead (300-Mil) SSOP	
5.4	74FCT162652CTPACT	Z56	56-Lead (240-Mil) TSSOP	Industrial
	CY74FCT162652CTPVC	O56	56-Lead (300-Mil) SSOP	
	74FCT162652CTPVCT	O56	56-Lead (300-Mil) SSOP	
6.3	CY74FCT162652ATPVC	O56	56-Lead (300-Mil) SSOP	Industrial
	74FCT162652ATPVCT	O56	56-Lead (300-Mil) SSOP	

Package Diagrams

56-Lead Shrunken Small Outline Package O56

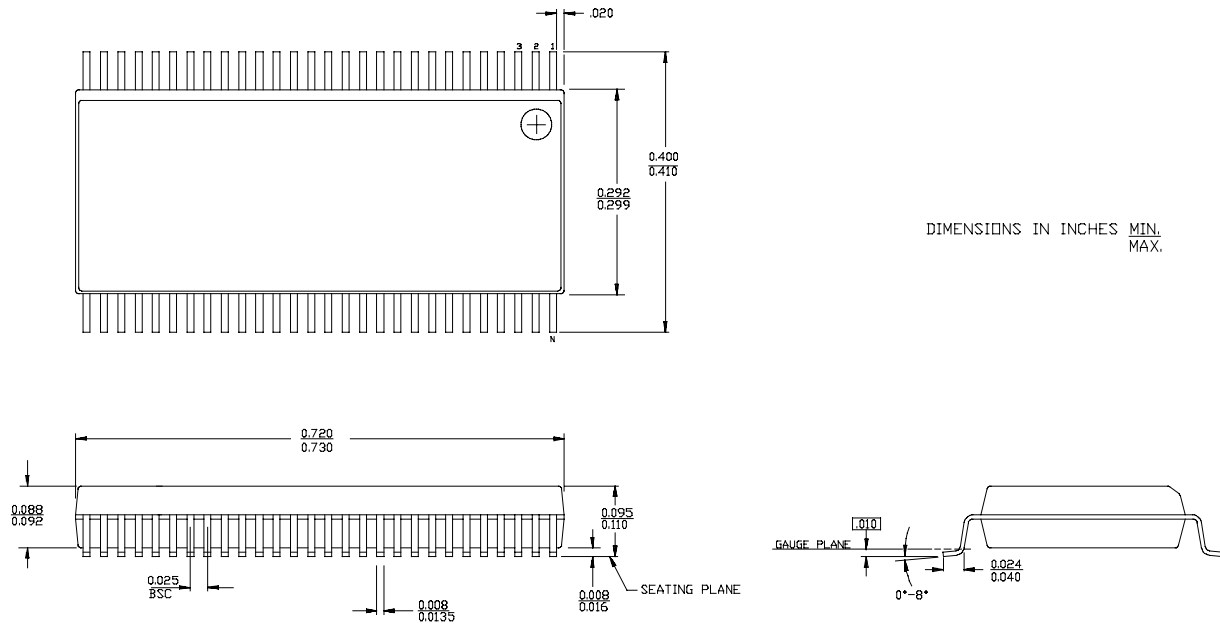

56-Lead Thin Shrunken Small Outline Package Z56

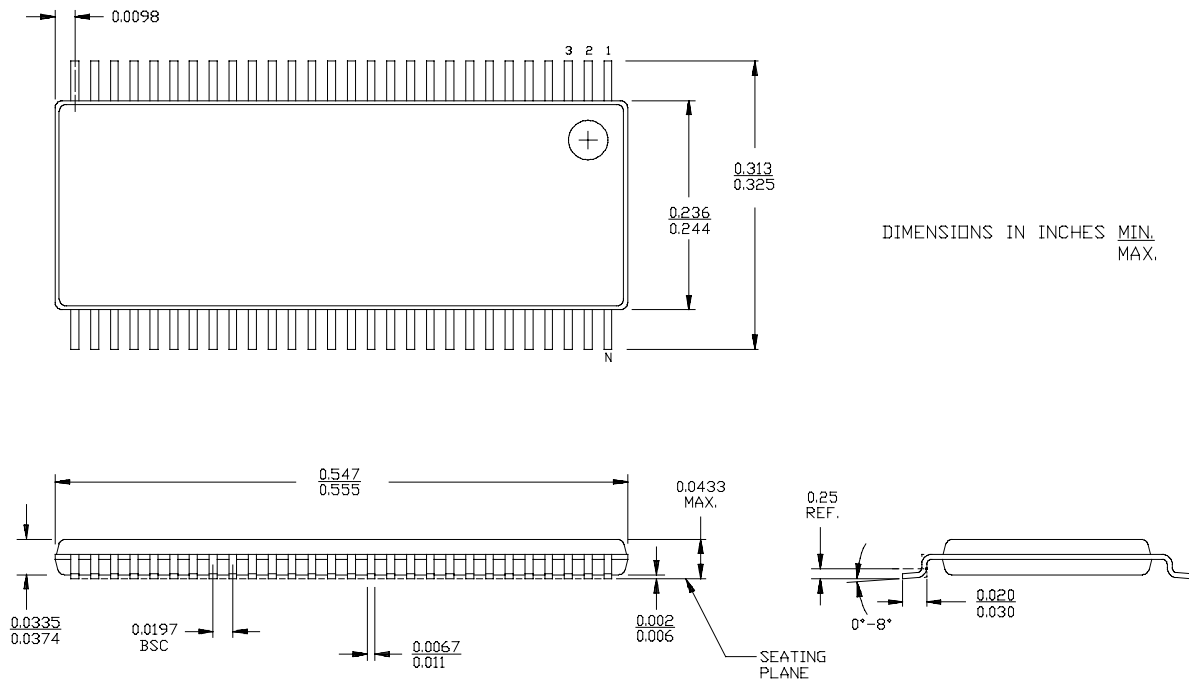

IMPORTANT NOTICE

Texas Instruments and its subsidiaries (TI) reserve the right to make changes to their products or to discontinue any product or service without notice, and advise customers to obtain the latest version of relevant information to verify, before placing orders, that information being relied on is current and complete. All products are sold subject to the terms and conditions of sale supplied at the time of order acknowledgement, including those pertaining to warranty, patent infringement, and limitation of liability.

TI warrants performance of its semiconductor products to the specifications applicable at the time of sale in accordance with TI's standard warranty. Testing and other quality control techniques are utilized to the extent TI deems necessary to support this warranty. Specific testing of all parameters of each device is not necessarily performed, except those mandated by government requirements.

CERTAIN APPLICATIONS USING SEMICONDUCTOR PRODUCTS MAY INVOLVE POTENTIAL RISKS OF DEATH, PERSONAL INJURY, OR SEVERE PROPERTY OR ENVIRONMENTAL DAMAGE ("CRITICAL APPLICATIONS"). TI SEMICONDUCTOR PRODUCTS ARE NOT DESIGNED, AUTHORIZED, OR WARRANTED TO BE SUITABLE FOR USE IN LIFE-SUPPORT DEVICES OR SYSTEMS OR OTHER CRITICAL APPLICATIONS. INCLUSION OF TI PRODUCTS IN SUCH APPLICATIONS IS UNDERSTOOD TO BE FULLY AT THE CUSTOMER'S RISK.

In order to minimize risks associated with the customer's applications, adequate design and operating safeguards must be provided by the customer to minimize inherent or procedural hazards.

TI assumes no liability for applications assistance or customer product design. TI does not warrant or represent that any license, either express or implied, is granted under any patent right, copyright, mask work right, or other intellectual property right of TI covering or relating to any combination, machine, or process in which such semiconductor products or services might be or are used. TI's publication of information regarding any third party's products or services does not constitute TI's approval, warranty or endorsement thereof.