



SCCS043 - September 1994 - Revised March 2000

CY74FCT2646T

8-Bit Registered Transceiver

Features

- Function and pinout compatible with FCT and F logic
- FCT-C speed at 5.4 ns max.
FCT-A speed at 6.3 ns max.
- Reduced V_{OH} (typically = 3.3V) versions of equivalent FCT functions
- 25Ω output series resistors to reduce transmission line reflection noise
- Reduced V_{OH} (typically=3.3V) versions of equivalent FCT functions
- Edge-rate control circuitry for significantly improved noise characteristics
- Power-off disable feature permits live insertion
- Matched rise and fall times
- ESD > 2000V
- Fully compatible with TTL input and output logic levels
- Sink current 12 mA
Source current 15 mA
- Independent register for A and B buses
- Extended commercial temp. range of -40°C to +85°C
- Three-state output

Functional Description

The FCT2646T consists of a bus transceiver circuit with three-state, D-type flip-flops, and control circuitry arranged for multiplexed transmission of data directly from the input bus or from the internal registers. Data on the A or B bus will be clocked into the registers as the appropriate clock pin goes to a HIGH logic level. Enable Control \bar{G} and direction pins are provided to control the transceiver function. On-chip termination resistors have been added to the outputs to reduce system noise caused by reflections so that the FCT2646T can be used to replace the FCT646T in an existing design.

In the transceiver mode, data present at the high impedance port may be stored in either the A or B register, or in both. Select controls can multiplex stored and real-time (transparent mode) data. The direction control determines which bus will receive data when the enable control \bar{G} is Active LOW. In the isolation mode (enable control \bar{G} HIGH), A data may be stored in the B register and/or B data may be stored in the A register.

The outputs are designed with a power-off disable feature to allow for live insertion of boards.

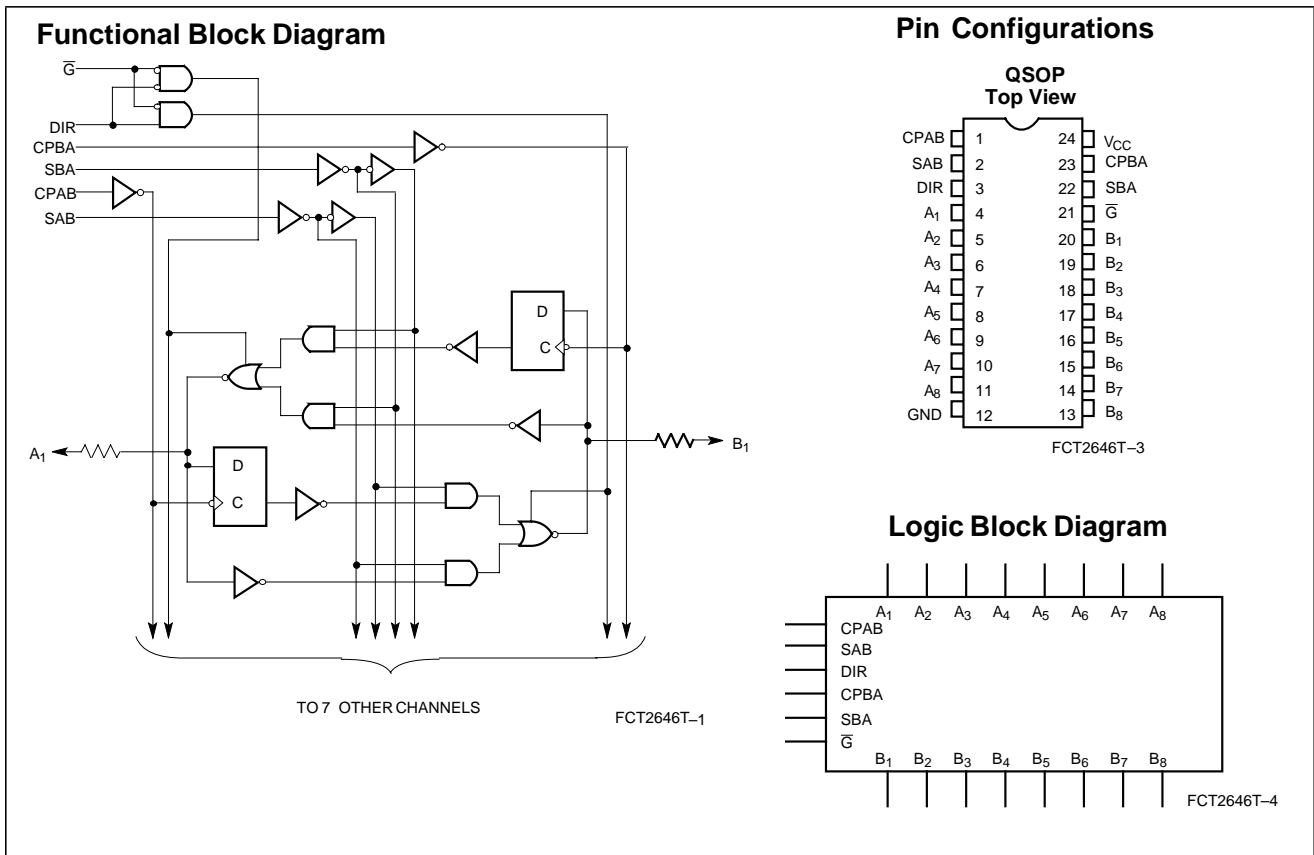

Pin Description

Name	Description
A	Data Register A Inputs, Data Register B Outputs
B	Data Register B Inputs, Data Register A Outputs
CPAB, CPBA	Clock Pulse Inputs
SAB, SBA	Output Data Source Select Inputs
DIR, \bar{G}	Output Enable Inputs

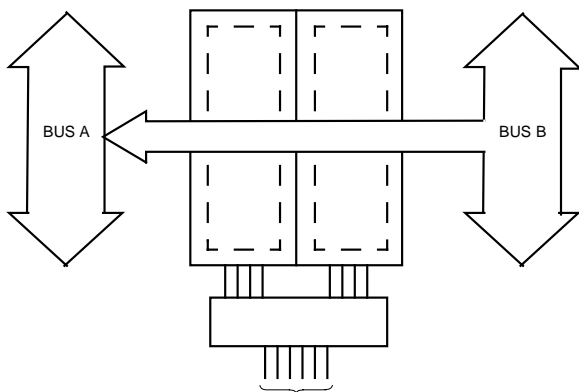

DIR L \bar{G} L CPAB X CPBA X SAB X SBA X

Real-Time Transfer
Bus B to Bus A

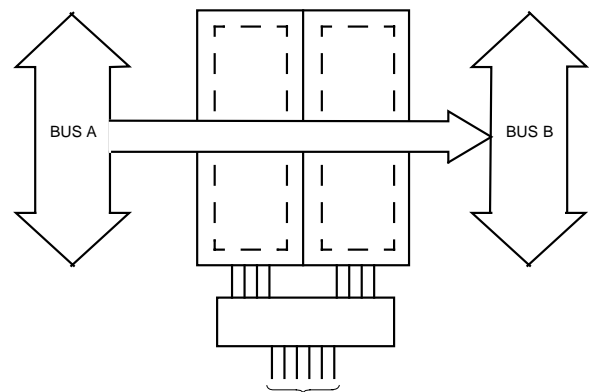

DIR H \bar{G} L CPAB X CPBA X SAB L SBA X

Real-Time Transfer
Bus A to Bus B

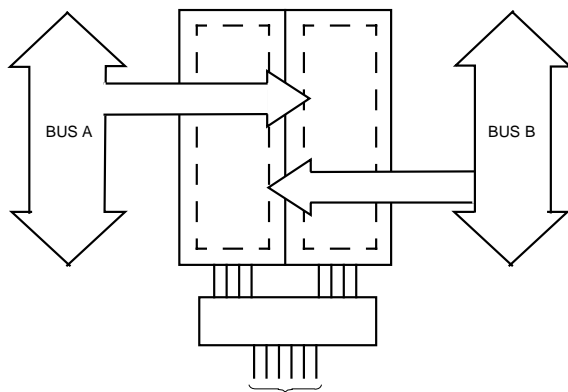

DIR H L X \bar{G} L L H CPAB \lceil X \lceil CPBA X \lceil \lceil SAB X X X SBA X X X

Storage from
A and/or B

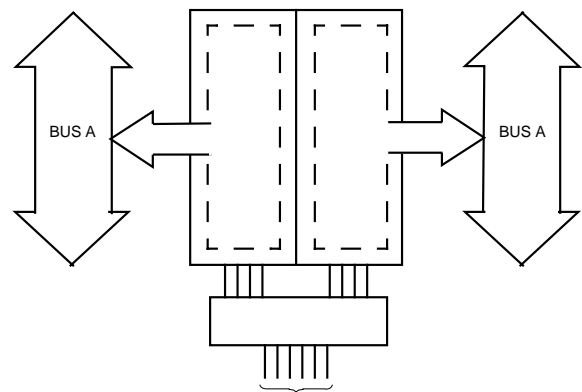

DIR^[1] L H \bar{G} L L CPAB X H or L CPBA H or L X SAB X H SBA H X

Transfer Stored Data
to A and/or B

Note:

1. Cannot transfer data to A bus and B bus simultaneously.

Function Table^[2]

Inputs						Data I/O ^[3]		Operation or Function
\bar{G}	DIR	CPAB	CPBA	SAB	SBA	A ₁ thru A ₈	B ₁ thru B ₈	FCT2646T
H H	X X	H or L ┐	H or L ┐	X X	X X	Input	Input	Isolation Store A and B Data
L L	L L	X X	X H or L	X X	L H	Output	Input	Real Time B Data to A Bus Stored B Data to A Bus
L L	H H	X H or L	X X	L H	X X	Input	Output	Real Time A Data to B Bus Stored A Data to B Bus

Maximum Ratings^[4, 5]

(Above which the useful life may be impaired. For user guidelines, not tested.)

Storage Temperature -65°C to +150°C

Ambient Temperature with
Power Applied -65°C to +135°C

Supply Voltage to Ground Potential -0.5V to +7.0V

DC Input Voltage -0.5V to +7.0V

DC Output Voltage -0.5V to +7.0V

DC Output Current (Maximum Sink Current/Pin) 120 mA
Power Dissipation 0.5W
Static Discharge Voltage >2001V
(per MIL-STD-883, Method 3015)

Operating Range

Range	Ambient Temperature	V _{CC}
Commercial	-40°C to +85°C	5V ± 5%

Electrical Characteristics Over the Operating Range

Parameter	Description	Test Conditions	Min.	Typ ^[6]	Max.	Unit
V _{OH}	Output HIGH Voltage	V _{CC} =Min., I _{OH} =-15 mA	2.4	3.3		V
V _{OL}	Output LOW Voltage	V _{CC} =Min., I _{OL} =12 mA		0.3	0.55	V
R _{OUT}	Output Resistance	V _{CC} =Min., I _{OL} =12 mA	20	25	40	Ω
V _{IH}	Input HIGH Voltage		2.0			V
V _{IL}	Input LOW Voltage				0.8	V
V _H	Hysteresis ^[7]	All inputs		0.2		V
V _{IK}	Input Clamp Diode Voltage	V _{CC} =Min., I _{IN} =-18 mA		-0.7	-1.2	V
I _{IH}	Input HIGH Current	V _{CC} =Max., V _{IN} =V _{CC}			5	μA
I _{IH}	Input HIGH Current	V _{CC} =Max., V _{IN} =2.7V			±1	μA
I _{IL}	Input LOW Current	V _{CC} =Max., V _{IN} =0.5V			±1	μA
I _{OS}	Output Short Circuit Current ^[8]	V _{CC} =Max., V _{OUT} =0.0V	-60	-120	-225	mA
I _{OFF}	Power-Off Disable	V _{CC} =0V, V _{OUT} =4.5V			±1	μA

Notes:

- H = HIGH Voltage Level. L = LOW Voltage Level. X = Don't Care.
- The data output functions may be enabled or disabled by various signals at the G or DIR inputs. Data input functions are always enabled, i.e., data at the bus pins will be stored on every LOW-to-HIGH transition of the clock inputs.
- Unless otherwise noted, these limits are over the operating free-air temperature range.
- Unused inputs must always be connected to an appropriate logic voltage level, preferably either V_{CC} or ground.
- Typical values are at V_{CC}=5.0V, T_A=+25°C ambient.
- This parameter is specified but not tested.
- Not more than one output should be shorted at a time. Duration of short should not exceed one second. The use of high-speed test apparatus and/or sample and hold techniques are preferable in order to minimize internal chip heating and more accurately reflect operational values. Otherwise prolonged shorting of a high output may raise the chip temperature well above normal and thereby cause invalid readings in other parametric tests. In any sequence of parameter tests, I_{OS} tests should be performed last.

Capacitance^[7]

Parameter	Description	Typ. ^[6]	Max.	Unit
C _{IN}	Input Capacitance	6	10	pF
C _{OUT}	Output Capacitance	8	12	pF

Power Supply Characteristics

Parameter	Description	Test Conditions	Typ. ^[6]	Max.	Unit
I _{CC}	Quiescent Power Supply Current	V _{CC} =Max., V _{IN} ≤0.2V, V _{IN} ≥V _{CC} -0.2V	0.1	0.2	mA
ΔI _{CC}	Quiescent Power Supply Current (TTL inputs HIGH)	V _{CC} =Max., V _{IN} =3.4V, ^[9] f ₁ =0, Outputs Open	0.5	2.0	mA
I _{CCD}	Dynamic Power Supply Current ^[10]	V _{CC} =Max., One Input Toggling, 50% Duty Cycle, Outputs Open, G=DIR=GND, GAB=GBA=GND, V _{IN} ≤0.2V or V _{IN} ≥V _{CC} -0.2V	0.06	0.12	mA/ MHz
I _C	Total Power Supply Current ^[11]	V _{CC} =Max., f ₀ =10 MHz, 50% Duty Cycle, Outputs Open, One Bit Toggling at f ₁ =5 MHz, G=DIR=GND, GAB=GBA=GND, V _{IN} ≤0.2V or V _{IN} ≥V _{CC} -0.2V	0.7	1.4	mA
		V _{CC} =Max., f ₀ =10 MHz, 50% Duty Cycle, Outputs Open, One Bit Toggling at f ₁ =5 MHz, G=DIR=GND, GAB=GBA=GND, V _{IN} =3.4V or V _{IN} =GND	1.2	3.4	mA
		V _{CC} =Max., f ₀ =10 MHz, 50% Duty Cycle, Outputs Open, Eight Bits Toggling at f ₁ =5 MHz, G=DIR=GND, GAB=GBA=GND, V _{IN} ≤0.2V or V _{IN} ≥V _{CC} -0.2V	2.8	5.6 ^[12]	mA
		V _{CC} =Max., f ₀ =10 MHz, 50% Duty Cycle, Outputs Open, Eight Bits Toggling at f ₁ =5 MHz, G=DIR=GND, GAB=GBA=GND, V _{IN} =3.4V or V _{IN} =GND	5.1	14.6 ^[12]	mA

Notes:

9. Per TTL driven input (V_{IN}=3.4V); all other inputs at V_{CC} or GND.
10. This parameter is not directly testable, but is derived for use in Total Power Supply calculations.
11. $I_C = I_{\text{QUIESCENT}} + I_{\text{INPUTS}} + I_{\text{DYNAMIC}}$
 $I_C = I_{\text{CC}} + \Delta I_{\text{CC}} D_H N_T + I_{\text{CCD}} (f_0/2 + f_1 N_1)$
 I_{CC} = Quiescent Current with CMOS input levels
 ΔI_{CC} = Power Supply Current for a TTL HIGH input (V_{IN}=3.4V)
 D_H = Duty Cycle for TTL inputs HIGH
 N_T = Number of TTL inputs at D_H
 I_{CCD} = Dynamic Current caused by an input transition pair (HLH or LHL)
 f_0 = Clock frequency for registered devices, otherwise zero
 f_1 = Input signal frequency
 N_1 = Number of inputs changing at f₁
 All currents are in milliamps and all frequencies are in megahertz.
12. Values for these conditions are examples of the I_{CC} formula. These limits are specified but not tested.

Switching Characteristics Over the Operating Range^[13]

Parameter	Description	CY74FCT2646AT		CY74FCT2646CT		Unit	Fig. No. ^[14]
		Min.	Max.	Min.	Max.		
t _{PLH} t _{PHL}	Propagation Delay Bus to Bus	1.5	6.3	1.5	5.4	ns	1, 3
t _{PZH} t _{PZL}	Output Enable Time Enable to Bus and DIR to A _n or B _n	1.5	9.8	1.5	7.8	ns	1, 7, 8
t _{PHZ} t _{PLZ}	Output Disable Time \bar{G} to Bus and DIR to Bus	1.5	6.3	1.5	6.3	ns	1, 7, 8
t _{PLH} t _{PHL}	Propagation Delay Clock to Bus	1.5	6.3	1.5	5.7	ns	1, 5
t _{PLH} t _{PHL}	Propagation Delay SBA or SAB to A or B	1.5	7.7	1.5	6.2	ns	1, 5
t _S	Set-Up Time HIGH or LOW, Bus to Clock	2.0		2.0		ns	4
t _H	Hold Time HIGH or LOW, Bus to Clock	1.5		1.5		ns	4
t _W	Pulse Width, ^[7] HIGH or LOW	5.0		5.0		ns	5

Notes:

13. Minimum limits are specified but not tested on Propagation Delays.

14. See "Parameter Measurement Information" in the General Information section.

Ordering Information

Speed (ns)	Ordering Code	Package Name	Package Type	Operating Range
5.4	CY74FCT2646CTQCT	Q13	24-Lead (150-Mil) QSOP	Commercial
6.3	CY74FCT2646ATQCT	Q13	24-Lead (150-Mil) QSOP	Commercial

Document #: 38-00599

Package Diagrams

24-Lead Quarter Size Outline Q13

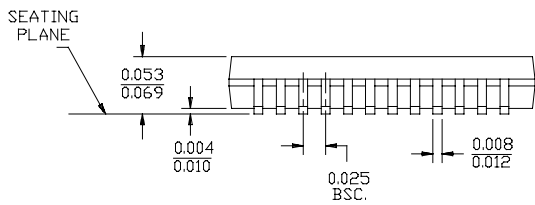
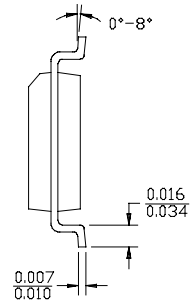
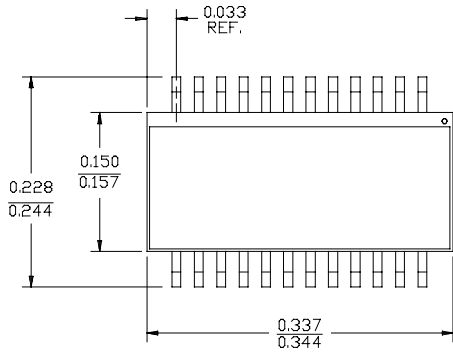

DIMENSIONS IN INCHES MIN.
MAX.
LEAD COPLANARITY 0.004 MAX.

IMPORTANT NOTICE

Texas Instruments and its subsidiaries (TI) reserve the right to make changes to their products or to discontinue any product or service without notice, and advise customers to obtain the latest version of relevant information to verify, before placing orders, that information being relied on is current and complete. All products are sold subject to the terms and conditions of sale supplied at the time of order acknowledgement, including those pertaining to warranty, patent infringement, and limitation of liability.

TI warrants performance of its semiconductor products to the specifications applicable at the time of sale in accordance with TI's standard warranty. Testing and other quality control techniques are utilized to the extent TI deems necessary to support this warranty. Specific testing of all parameters of each device is not necessarily performed, except those mandated by government requirements.

CERTAIN APPLICATIONS USING SEMICONDUCTOR PRODUCTS MAY INVOLVE POTENTIAL RISKS OF DEATH, PERSONAL INJURY, OR SEVERE PROPERTY OR ENVIRONMENTAL DAMAGE ("CRITICAL APPLICATIONS"). TI SEMICONDUCTOR PRODUCTS ARE NOT DESIGNED, AUTHORIZED, OR WARRANTED TO BE SUITABLE FOR USE IN LIFE-SUPPORT DEVICES OR SYSTEMS OR OTHER CRITICAL APPLICATIONS. INCLUSION OF TI PRODUCTS IN SUCH APPLICATIONS IS UNDERSTOOD TO BE FULLY AT THE CUSTOMER'S RISK.

In order to minimize risks associated with the customer's applications, adequate design and operating safeguards must be provided by the customer to minimize inherent or procedural hazards.

TI assumes no liability for applications assistance or customer product design. TI does not warrant or represent that any license, either express or implied, is granted under any patent right, copyright, mask work right, or other intellectual property right of TI covering or relating to any combination, machine, or process in which such semiconductor products or services might be or are used. TI's publication of information regarding any third party's products or services does not constitute TI's approval, warranty or endorsement thereof.