

SN74ALS638A, SN74ALS639A, SN74AS638A, SN74AS639 OCTAL BUS TRANSCEIVERS

SDAS123A – DECEMBER 1983 – REVISED JANUARY 1995

- Bidirectional Bus Transceivers in High-Density 20-Pin Packages
- Choice of True or Inverting Logic
- A-Bus Outputs Are Open Collector; B-Bus Outputs Are 3 State
- Package Options Include Plastic Small-Outline (DW) Packages and Standard Plastic (N) 300-mil DIPs

DW OR N PACKAGE
(TOP VIEW)

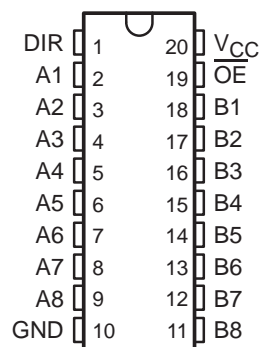

DEVICE	A OUTPUT	B OUTPUT	LOGIC
SN74ALS638A, SN74AS638A	Open collector	3 state	Inverting
SN74ALS639A, SN74AS639	Open collector	3 state	True

description

These octal bus transceivers are designed for asynchronous two-way communication between open-collector and 3-state buses. The devices transmit data from the A bus (open-collector) to the B bus (3 state) or from the B bus to the A bus, depending on the logic level at the direction-control (DIR) input. The output-enable (\overline{OE}) input can be used to disable the device so the buses are isolated.

The -1 version of SN74ALS638A is identical to the standard version, except that the recommended maximum I_{OL} is increased to 48 mA.

The SN74ALS638A, SN74ALS639A, SN74AS638A, and SN74AS639 are characterized for operation from 0°C to 70°C.

FUNCTION TABLE

INPUTS		OPERATION	
\overline{OE}	DIR	SN74ALS638A SN74AS638A	SN74ALS639A SN74AS639
L	L	\overline{B} data to A bus	B data to A bus
L	H	\overline{A} data to B bus	A data to B bus
H	X	Isolation	Isolation

PRODUCTION DATA information is current as of publication date. Products conform to specifications per the terms of Texas Instruments standard warranty. Production processing does not necessarily include testing of all parameters.



POST OFFICE BOX 655303 • DALLAS, TEXAS 75265

Copyright © 1995, Texas Instruments Incorporated

SN74ALS638A, SN74ALS639A, SN74AS638A, SN74AS639

OCTAL BUS TRANSCEIVERS

SDAS123A – DECEMBER 1983 – REVISED JANUARY 1995

logic symbols†

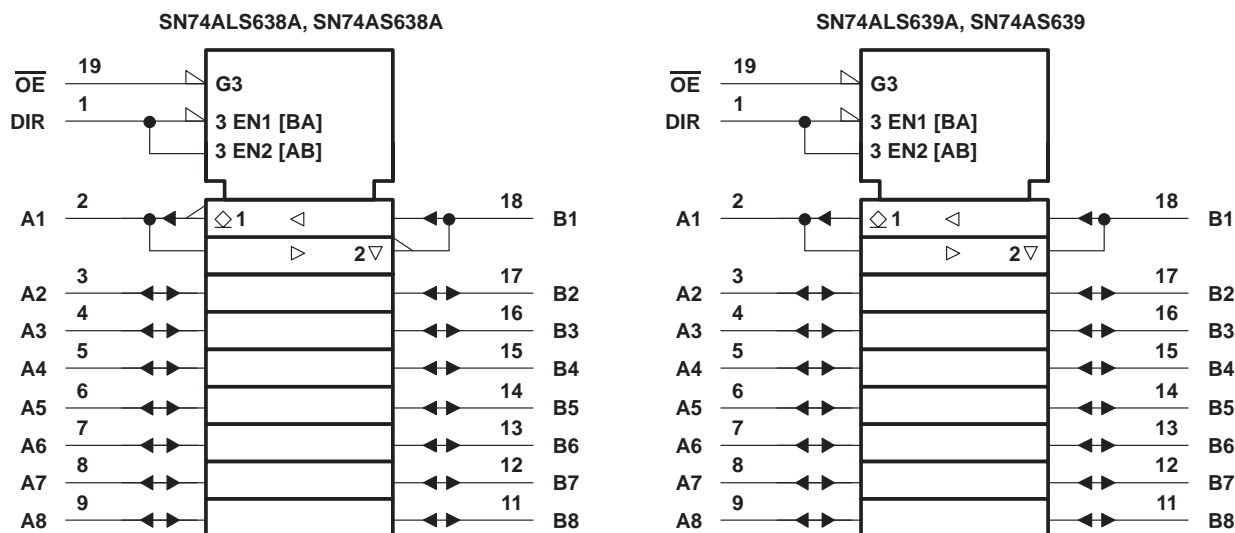

† These symbols are in accordance with ANSI/IEEE Std 91-1984 and IEC Publication 617-12.

logic diagrams (positive logic)

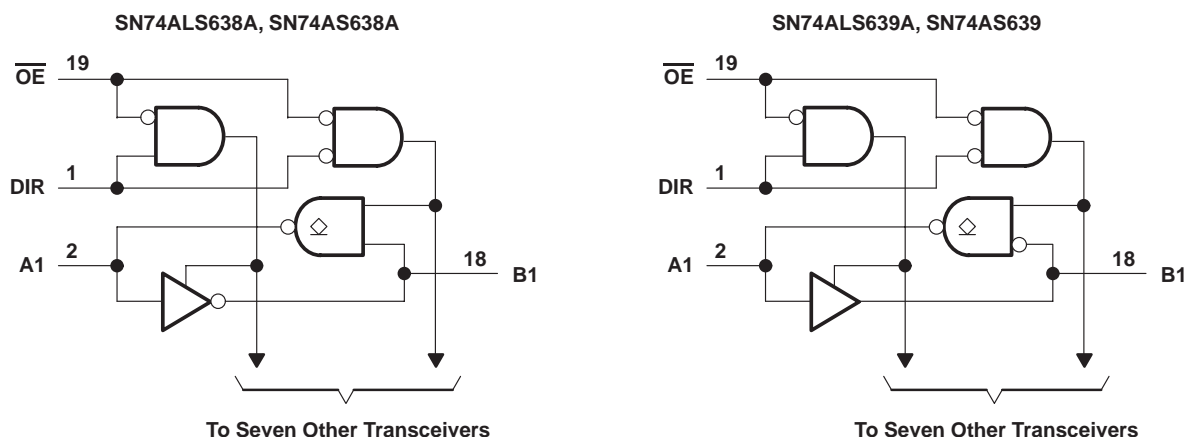

absolute maximum ratings over operating free-air temperature range (unless otherwise noted)‡

Supply voltage, V_{CC}	7 V
Input voltage, V_I : All inputs	7 V
A-bus I/O ports	7 V
B-bus I/O ports	5.5 V
Operating free-air temperature range, T_A : SN74ALS638A, SN74ALS639A	0°C to 70°C
Storage temperature range	-65°C to 150°C

‡ Stresses beyond those listed under "absolute maximum ratings" may cause permanent damage to the device. These are stress ratings only, and functional operation of the device at these or any other conditions beyond those indicated under "recommended operating conditions" is not implied. Exposure to absolute-maximum-rated conditions for extended periods may affect device reliability.



POST OFFICE BOX 655303 • DALLAS, TEXAS 75265

SN74ALS638A, SN74ALS639A, SN74AS638A, SN74AS639A OCTAL BUS TRANSCEIVERS

SDAS123A – DECEMBER 1983 – REVISED JANUARY 1995

recommended operating conditions

		SN74ALS638A SN74ALS639A			UNIT
		MIN	NOM	MAX	
V_{CC}	Supply voltage	4.5	5	5.5	V
V_{IH}	High-level input voltage	2			V
V_{IL}	Low-level input voltage			0.8	V
V_{OH}	High-level output voltage			5.5	V
I_{OH}	High-level output current			-15	mA
I_{OL}	Low-level output current			24	mA
				48†	
T_A	Operating free-air temperature	0		70	°C

† Applies only to the SN74ALS638A-1 version and only if V_{CC} is between 4.75 V and 5.25 V

electrical characteristics over recommended operating free-air temperature range (unless otherwise noted)

PARAMETER		TEST CONDITIONS		SN74ALS638A SN74ALS639A		UNIT
				MIN	TYP‡	
V_{IK}		$V_{CC} = 4.5\text{ V}$,	$I_I = -18\text{ mA}$		-1.5	V
I_{OH}	A ports	$V_{CC} = 4.5\text{ V}$,	$V_{OH} = 5.5\text{ V}$		0.1	mA
V_{OH}	B ports	$V_{CC} = 4.5\text{ V to } 5.5\text{ V}$,	$I_{OH} = -0.4\text{ mA}$	$V_{CC} - 2$		V
		$V_{CC} = 4.5\text{ V}$	$I_{OH} = -3\text{ mA}$	2.4	3.2	
V_{OL}	A or B ports	$V_{CC} = 4.5\text{ V}$	$I_{OL} = -15\text{ mA}$	2		V
			$I_{OL} = 12\text{ mA}$	0.25	0.4	
			$I_{OL} = 24\text{ mA}$	0.35	0.5	
I_{OL}	A or B ports	$V_{CC} = 4.5\text{ V}$	$I_{OL} = 48\text{ mA}^\dagger$	0.35	0.5	V
I_I	Control inputs	$V_{CC} = 5.5\text{ V}$	$V_I = 7\text{ V}$		0.1	mA
	A or B ports		$V_I = 5.5\text{ V}$		0.1	
I_{IH}	Control inputs	$V_{CC} = 5.5\text{ V}$,	$V_I = 2.7\text{ V}$		20	μA
	A or B ports§				20	
I_{IL}	Control inputs	$V_{CC} = 5.5\text{ V}$,	$V_I = 0.4\text{ V}$		-0.1	mA
	A or B ports§				-0.1	
I_{O}^\parallel	B ports	$V_{CC} = 5.5\text{ V}$,	$V_O = 2.25\text{ V}$	-30	-112	mA
I_{CC}	SN74ALS638A	$V_{CC} = 5.5\text{ V}$	Outputs high	18	30	mA
			Outputs low	26	41	
			Outputs disabled	16	30	
	SN74ALS639A	$V_{CC} = 5.5\text{ V}$	Outputs high	25	40	
			Outputs low	30	50	
			Outputs disabled	33	54	

† Applies only to the SN74ALS638A-1 version and only if V_{CC} is between 4.75 V and 5.25 V

‡ All typical values are at $V_{CC} = 5\text{ V}$, $T_A = 25^\circ\text{C}$.

§ For I/O ports, the parameters I_{IH} and I_{IL} include the off-state output current.

¶ The output conditions have been chosen to produce a current that closely approximates one half of the true short-circuit output current, I_{OS} .



SN74ALS638A, SN74ALS639A, SN74AS638A, SN74AS639

OCTAL BUS TRANSCEIVERS

SDAS123A – DECEMBER 1983 – REVISED JANUARY 1995

switching characteristics (see Figure 1)

PARAMETER	FROM (INPUT)	TO (OUTPUT)	V _{CC} = 4.5 V to 5.5 V, C _L = 50 pF, R _L = 680 Ω (A outputs), R _L = 500 Ω (B outputs), T _A = MIN to MAX†				UNIT
			SN74ALS638A		SN74ALS639A		
			MIN	MAX	MIN	MAX	
t _{PLH}	A	B	2	12	2	12	ns
t _{PHL}			2	12	2	12	
t _{PLH}	B	A	8	25	10	30	ns
t _{PHL}			8	30	5	22	
t _{PLH}	\overline{OE}	A	5	25	10	30	ns
t _{PHL}			10	45	10	35	
t _{PZH}	\overline{OE}	B	5	20	6	21	ns
t _{PZL}			5	22	8	25	
t _{PHZ}	\overline{OE}	B	2	10	2	10	ns
t _{PLZ}			3	15	3	16	

† For conditions shown as MIN or MAX, use the appropriate value specified under recommended operating conditions.

absolute maximum ratings over operating free-air temperature range (unless otherwise noted)‡

Supply voltage, V _{CC}	7 V
Input voltage, V _I : All inputs	7 V
A-bus I/O ports	7 V
B-bus I/O ports	5.5 V
Operating free-air temperature range, T _A : SN74AS638A, SN74AS639	0°C to 70°C
Storage temperature range	–65°C to 150°C

‡ Stresses beyond those listed under “absolute maximum ratings” may cause permanent damage to the device. These are stress ratings only, and functional operation of the device at these or any other conditions beyond those indicated under “recommended operating conditions” is not implied. Exposure to absolute-maximum-rated conditions for extended periods may affect device reliability.

recommended operating conditions

		SN74AS638A SN74AS639			UNIT
		MIN	NOM	MAX	
V _{CC}	Supply voltage	4.5	5	5.5	V
V _{IH}	High-level input voltage	2			V
V _{IL}	Low-level input voltage			0.8	V
V _{OH}	High-level output voltage			5.5	V
I _{OH}	High-level output current			–15	mA
I _{OL}	Low-level output current			64	mA
T _A	Operating free-air temperature	0		70	°C



POST OFFICE BOX 655303 • DALLAS, TEXAS 75265

SN74ALS638A, SN74ALS639A, SN74AS638A, SN74AS639

OCTAL BUS TRANSCEIVERS

SDAS123A – DECEMBER 1983 – REVISED JANUARY 1995

electrical characteristics over recommended operating free-air temperature range (unless otherwise noted)

PARAMETER		TEST CONDITIONS		SN74AS638A SN74AS639		UNIT	
				MIN	TYP†		MAX
V _{IK}		V _{CC} = 4.5 V, I _I = -18 mA		-1.2		V	
I _{OH}	A ports	V _{CC} = 4.5 V, V _{OH} = 5.5 V		0.1		mA	
V _{OH}	B ports	V _{CC} = 4.5 V to 5.5 V, I _{OH} = -2 mA		V _{CC} - 2		V	
		V _{CC} = 4.5 V	I _{OH} = -3 mA	2.4	3.2		
			I _{OH} = -15 mA	2.4			
V _{OL}	A or B ports	V _{CC} = 4.5 V, I _{OL} = 64 mA		0.35	0.55	V	
I _I	Control inputs	V _{CC} = 5.5 V		V _I = 7 V		0.1	
	A or B ports			V _I = 5.5 V		0.1	
I _{IH}	Control inputs	V _{CC} = 5.5 V, V _I = 2.7 V		20		μA	
	A or B ports‡			70			
I _{IL}	Control inputs	V _{CC} = 5.5 V, V _I = 0.4 V		-0.5		mA	
	A or B ports‡			-0.75			
I _O §		V _{CC} = 5.5 V, V _O = 2.25 V		-50	-150	mA	
I _{CC}	SN74AS638A	V _{CC} = 5.5 V		Outputs high		24	54
				Outputs low		75	122
				Outputs disabled		37	61
	SN74AS639	V _{CC} = 5.5 V		Outputs high		56	92
				Outputs low		95	154
				Outputs disabled		62	100

† All typical values are at V_{CC} = 5 V, T_A = 25°C.

‡ For I/O ports, the parameters I_{IH} and I_{IL} include the off-state output current.

§ The output conditions have been chosen to produce a current that closely approximates one half of the true short-circuit output current, I_{OS}.

switching characteristics (see Figure 1)

PARAMETER	FROM (INPUT)	TO (OUTPUT)	V _{CC} = 4.5 V to 5.5 V, C _L = 50 pF, R _L = 500 Ω (A outputs), R ₁ = R ₂ = 500 Ω (B outputs), T _A = MIN to MAX††				UNIT
			SN74AS638A		SN74AS639		
			MIN	MAX	MIN	MAX	
t _{PLH}	A	B	2	7	2	9.5	ns
t _{PHL}			2	6.5	2	9	
t _{PLH}	B	A	5	20	5	22	ns
t _{PHL}			2	7	2	9	
t _{PLH}	\overline{OE}	A	5	19	5	21.5	ns
t _{PHL}			2	9	2	11.5	
t _{PZH}	\overline{OE}	B	2	8	2	10.5	ns
t _{PZL}			2	10	2	10.5	
t _{PHZ}	\overline{OE}	B	2	7	2	7	ns
t _{PLZ}			2	10	2	10.5	

†† For conditions shown as MIN or MAX, use the appropriate value specified under recommended operating conditions.



SN74ALS638A, SN74ALS639A, SN74AS638A, SN74AS639 OCTAL BUS TRANSCEIVERS

SDAS123A – DECEMBER 1983 – REVISED JANUARY 1995

PARAMETER MEASUREMENT INFORMATION SERIES 54ALS/74ALS AND 54AS/74AS DEVICES

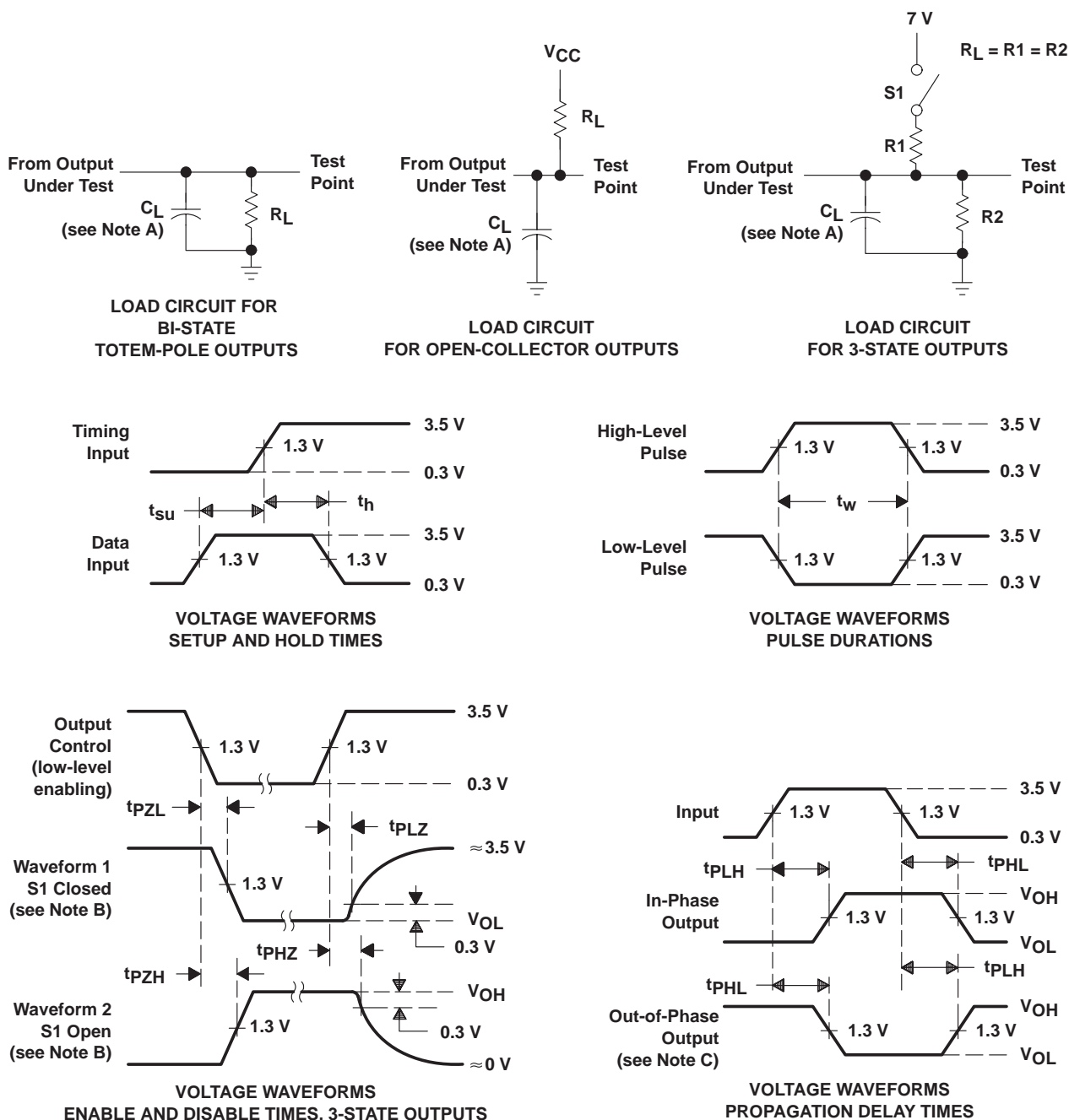

- NOTES: A. C_L includes probe and jig capacitance.
 B. Waveform 1 is for an output with internal conditions such that the output is low except when disabled by the output control. Waveform 2 is for an output with internal conditions such that the output is high except when disabled by the output control.
 C. When measuring propagation delay items of 3-state outputs, switch S1 is open.
 D. All input pulses have the following characteristics: $PRR \leq 1$ MHz, $t_r = t_f = 2$ ns, duty cycle = 50%.
 E. The outputs are measured one at a time with one transition per measurement.

Figure 1. Load Circuits and Voltage Waveforms



IMPORTANT NOTICE

Texas Instruments and its subsidiaries (TI) reserve the right to make changes to their products or to discontinue any product or service without notice, and advise customers to obtain the latest version of relevant information to verify, before placing orders, that information being relied on is current and complete. All products are sold subject to the terms and conditions of sale supplied at the time of order acknowledgement, including those pertaining to warranty, patent infringement, and limitation of liability.

TI warrants performance of its semiconductor products to the specifications applicable at the time of sale in accordance with TI's standard warranty. Testing and other quality control techniques are utilized to the extent TI deems necessary to support this warranty. Specific testing of all parameters of each device is not necessarily performed, except those mandated by government requirements.

CERTAIN APPLICATIONS USING SEMICONDUCTOR PRODUCTS MAY INVOLVE POTENTIAL RISKS OF DEATH, PERSONAL INJURY, OR SEVERE PROPERTY OR ENVIRONMENTAL DAMAGE ("CRITICAL APPLICATIONS"). TI SEMICONDUCTOR PRODUCTS ARE NOT DESIGNED, AUTHORIZED, OR WARRANTED TO BE SUITABLE FOR USE IN LIFE-SUPPORT DEVICES OR SYSTEMS OR OTHER CRITICAL APPLICATIONS. INCLUSION OF TI PRODUCTS IN SUCH APPLICATIONS IS UNDERSTOOD TO BE FULLY AT THE CUSTOMER'S RISK.

In order to minimize risks associated with the customer's applications, adequate design and operating safeguards must be provided by the customer to minimize inherent or procedural hazards.

TI assumes no liability for applications assistance or customer product design. TI does not warrant or represent that any license, either express or implied, is granted under any patent right, copyright, mask work right, or other intellectual property right of TI covering or relating to any combination, machine, or process in which such semiconductor products or services might be or are used. TI's publication of information regarding any third party's products or services does not constitute TI's approval, warranty or endorsement thereof.