

SN74ALS641A, SN74ALS642A, SN74AS641 OCTAL BUS TRANSCEIVERS WITH OPEN-COLLECTOR OUTPUTS

SDAS300 – MARCH 1995

- Bidirectional Bus Transceivers in High-Density 20-Pin Packages
- Choice of True or Inverting Logic
- Package Options Include Plastic Small-Outline (DW) Packages and Standard Plastic (N) 300-mil DIPs

DEVICE	LOGIC
SN74ALS641A, SN74AS641	True
SN74ALS642A	Inverting

description

These octal bus transceivers are designed for asynchronous two-way communication between data buses. These devices transmit data from the A bus to the B bus or from the B bus to the A bus, depending upon the level at the direction-control (DIR) input. The output-enable (\overline{OE}) input disables the device so that the buses are effectively isolated.

The -1 versions of the SN74ALS641A and SN74ALS642A are identical to the standard versions, except that the recommended maximum I_{OL} is increased to 48 mA in the -1 versions.

The SN74ALS641A, SN74ALS642A, and SN74AS641 are characterized for operation from 0°C to 70°C.

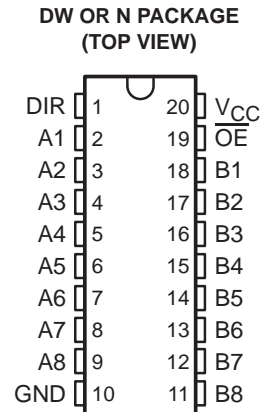

FUNCTION TABLE

INPUTS		OPERATION	
\overline{OE}	DIR	SN74ALS641A SN74AS641	SN74ALS642A
L	L	B data to A bus	\overline{B} data to A bus
L	H	A data to B bus	\overline{A} data to B bus
H	X	Isolation	Isolation

logic symbols†

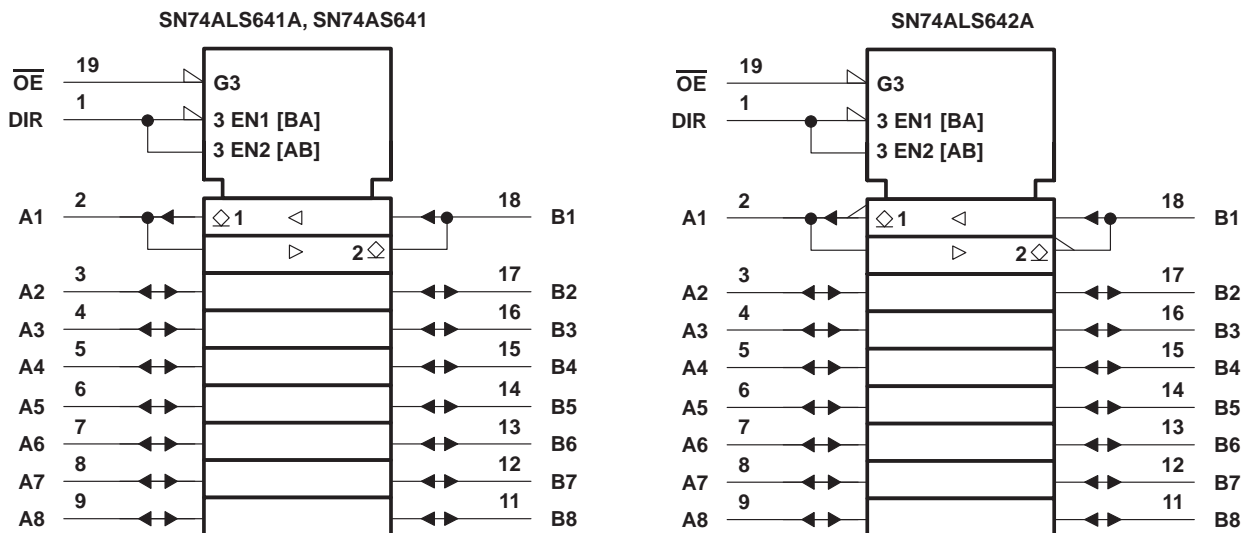

† These symbols are in accordance with ANSI/IEEE Std 91-1984 and IEC Publication 617-12.

PRODUCTION DATA information is current as of publication date. Products conform to specifications per the terms of Texas Instruments standard warranty. Production processing does not necessarily include testing of all parameters.

**TEXAS
INSTRUMENTS**

POST OFFICE BOX 655303 • DALLAS, TEXAS 75265

Copyright © 1995, Texas Instruments Incorporated

SN74ALS641A, SN74ALS642A, SN74AS641 OCTAL BUS TRANSCEIVERS WITH OPEN-COLLECTOR OUTPUTS

SDAS300 – MARCH 1995

logic diagrams (positive logic)

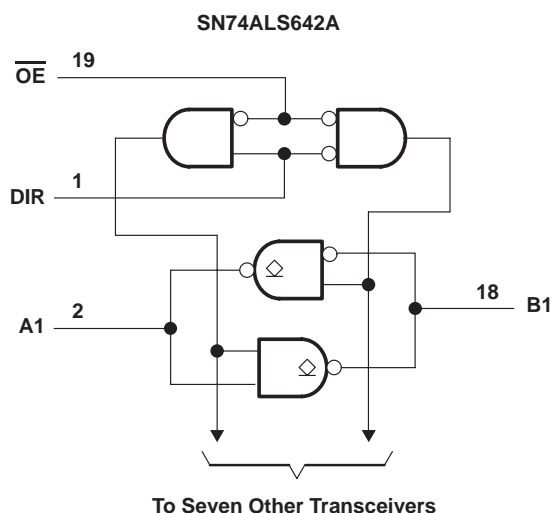
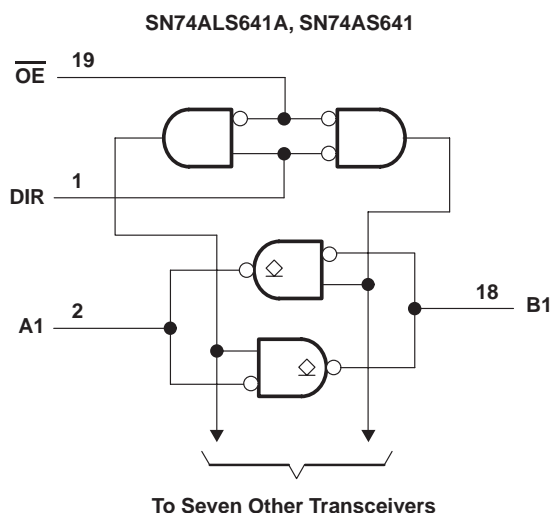

absolute maximum ratings over operating free-air temperature range (unless otherwise noted)†

Supply voltage, V_{CC}	7 V
Input voltage, V_I : All inputs and I/O ports	7 V
Operating free-air temperature range, T_A : SN74ALS641A, SN74ALS642A	0°C to 70°C
Storage temperature range	-65°C to 150°C

† Stresses beyond those listed under "absolute maximum ratings" may cause permanent damage to the device. These are stress ratings only, and functional operation of the device at these or any other conditions beyond those indicated under "recommended operating conditions" is not implied. Exposure to absolute-maximum-rated conditions for extended periods may affect device reliability.

recommended operating conditions

		SN74ALS641A SN74ALS642A			UNIT
		MIN	NOM	MAX	
V_{CC}	Supply voltage	4.5	5	5.5	V
V_{IH}	High-level input voltage	2			V
V_{IL}	Low-level input voltage			0.8	V
V_{OH}	High-level output voltage			5.5	V
I_{OL}	Low-level output current			24	mA
				48‡	
T_A	Operating free-air temperature	0		70	°C

‡ Applies only to the -1 version and only if V_{CC} is between 4.75 V and 5.25 V



POST OFFICE BOX 655303 • DALLAS, TEXAS 75265

SN74ALS641A, SN74ALS642A, SN74AS641
OCTAL BUS TRANSCEIVERS
WITH OPEN-COLLECTOR OUTPUTS

SDAS300 – MARCH 1995

electrical characteristics over recommended operating free-air temperature range (unless otherwise noted)

PARAMETER		TEST CONDITIONS		SN74ALS641A SN74ALS642A		UNIT
				MIN	TYP†	
V _{IK}		V _{CC} = 4.5 V,	I _I = -18 mA		-1.5	V
I _{OH}		V _{CC} = 4.5 V,	V _{OH} = 5.5 V		0.1	mA
V _{OL}		V _{CC} = 4.5 V		I _{OL} = 12 mA	0.25	0.4
				I _{OL} = 24 mA	0.35	0.5
				I _{OL} = 48 mA‡	0.35	0.5
I _I	Control inputs	V _{CC} = 5.5 V,	V _I = 7 V		0.1	mA
I _{IH}	Control inputs	V _{CC} = 5.5 V,	V _I = 2.7 V		20	μA
	A or B ports§				20	
I _{IL}	Control inputs	V _{CC} = 5.5 V,	V _I = 0.4 V		-0.1	mA
	A or B ports§				-0.1	
I _{CC}	SN74ALS641A	V _{CC} = 5.5 V		Outputs high	25	37
				Outputs low	33	47
	SN74ALS642A			Outputs high	8	15
				Outputs low	18	28

† All typical values are at V_{CC} = 5 V, T_A = 25°C.

‡ Applies only to the -1 version and only if V_{CC} is between 4.75 V and 5.25 V

§ For I/O ports, the parameters I_{IH} and I_{IL} include the off-state output current.

switching characteristics (see Figure 1)

PARAMETER	FROM (INPUT)	TO (OUTPUT)	V _{CC} = 4.5 V to 5.5 V, C _L = 50 pF, R _L = 680 Ω, T _A = MIN to MAX¶				UNIT
			SN74ALS641A		SN74ALS642A		
			MIN	MAX	MIN	MAX	
t _{PLH}	A or B	B or A	5	25	10	30	ns
t _{PHL}			3	18	5	22	
t _{PLH}	OE	A or B	8	30	10	30	ns
t _{PHL}			8	30	15	38	
t _{PLH}	DIR	A or B	8	32	10	30	ns
t _{PHL}			8	32	15	38	

¶ For conditions shown as MIN or MAX, use the appropriate value specified under recommended operating conditions.



SN74ALS641A, SN74ALS642A, SN74AS641

OCTAL BUS TRANSCEIVERS

WITH OPEN-COLLECTOR OUTPUTS

SDAS300 – MARCH 1995

absolute maximum ratings over operating free-air temperature range (unless otherwise noted)†

Supply voltage, V_{CC}	7 V
Input voltage, V_I : All inputs and I/O ports	7 V
Operating free-air temperature range, T_A : SN74AS641	0°C to 70°C
Storage temperature range	-65°C to 150°C

† Stresses beyond those listed under "absolute maximum ratings" may cause permanent damage to the device. These are stress ratings only, and functional operation of the device at these or any other conditions beyond those indicated under "recommended operating conditions" is not implied. Exposure to absolute-maximum-rated conditions for extended periods may affect device reliability.

recommended operating conditions

		SN74AS641			UNIT
		MIN	NOM	MAX	
V_{CC}	Supply voltage	4.5	5	5.5	V
V_{IH}	High-level input voltage	2			V
V_{IL}	Low-level input voltage			0.8	V
V_{OH}	High-level output voltage			5.5	V
I_{OL}	Low-level output current			64	mA
T_A	Operating free-air temperature	0		70	°C

electrical characteristics over recommended operating free-air temperature range (unless otherwise noted)

PARAMETER	TEST CONDITIONS	SN74AS641			UNIT	
		MIN	TYP‡	MAX		
V_{IK}	$V_{CC} = 4.5$ V, $I_I = -18$ mA			-1.2	V	
I_{OH}	$V_{CC} = 4.5$ V, $V_{OH} = 5.5$ V			0.1	mA	
V_{OL}	$V_{CC} = 4.5$ V, $I_{OL} = 64$ mA		0.35	0.55	V	
I_I	Control inputs	$V_{CC} = 5.5$ V		$V_I = 7$ V	0.1	mA
	A or B ports			$V_I = 5.5$ V	0.1	
I_{IH}	Control inputs	$V_{CC} = 5.5$ V,	$V_I = 2.7$ V		20	μ A
	A or B ports§				70	
I_{IL}	Control inputs	$V_{CC} = 5.5$ V,	$V_I = 0.4$ V		-0.5	mA
	A or B ports§				-0.75	
I_{CC}	$V_{CC} = 5.5$ V	Outputs high		50	82	mA
		Outputs low		84	136	

‡ All typical values are at $V_{CC} = 5$ V, $T_A = 25^\circ\text{C}$.

§ For I/O ports, the parameters I_{IH} and I_{IL} include the off-state output current.



POST OFFICE BOX 655303 • DALLAS, TEXAS 75265

SN74ALS641A, SN74ALS642A, SN74AS641
OCTAL BUS TRANSCEIVERS
WITH OPEN-COLLECTOR OUTPUTS

SDAS300 – MARCH 1995

switching characteristics (see Figure 1)

PARAMETER	FROM (INPUT)	TO (OUTPUT)	V _{CC} = 4.5 V to 5.5 V, C _L = 50 pF, R _L = 680 Ω, T _A = MIN to MAX†		UNIT
			SN74AS641		
			MIN	MAX	
t _{PLH}	A or B	B or A	5	21	ns
t _{PHL}			1	7.5	
t _{PLH}	\overline{OE}	A or B	5	21	ns
t _{PHL}			1	9	
t _{PLH}	DIR	A or B	5	22	ns
t _{PHL}			1	10	

† For conditions shown as MIN or MAX, use the appropriate value specified under recommended operating conditions.



SN74ALS641A, SN74ALS642A, SN74AS641 OCTAL BUS TRANSCEIVERS WITH OPEN-COLLECTOR OUTPUTS

SDAS300 – MARCH 1995

PARAMETER MEASUREMENT INFORMATION SERIES 54ALS/74ALS AND 54AS/74AS DEVICES

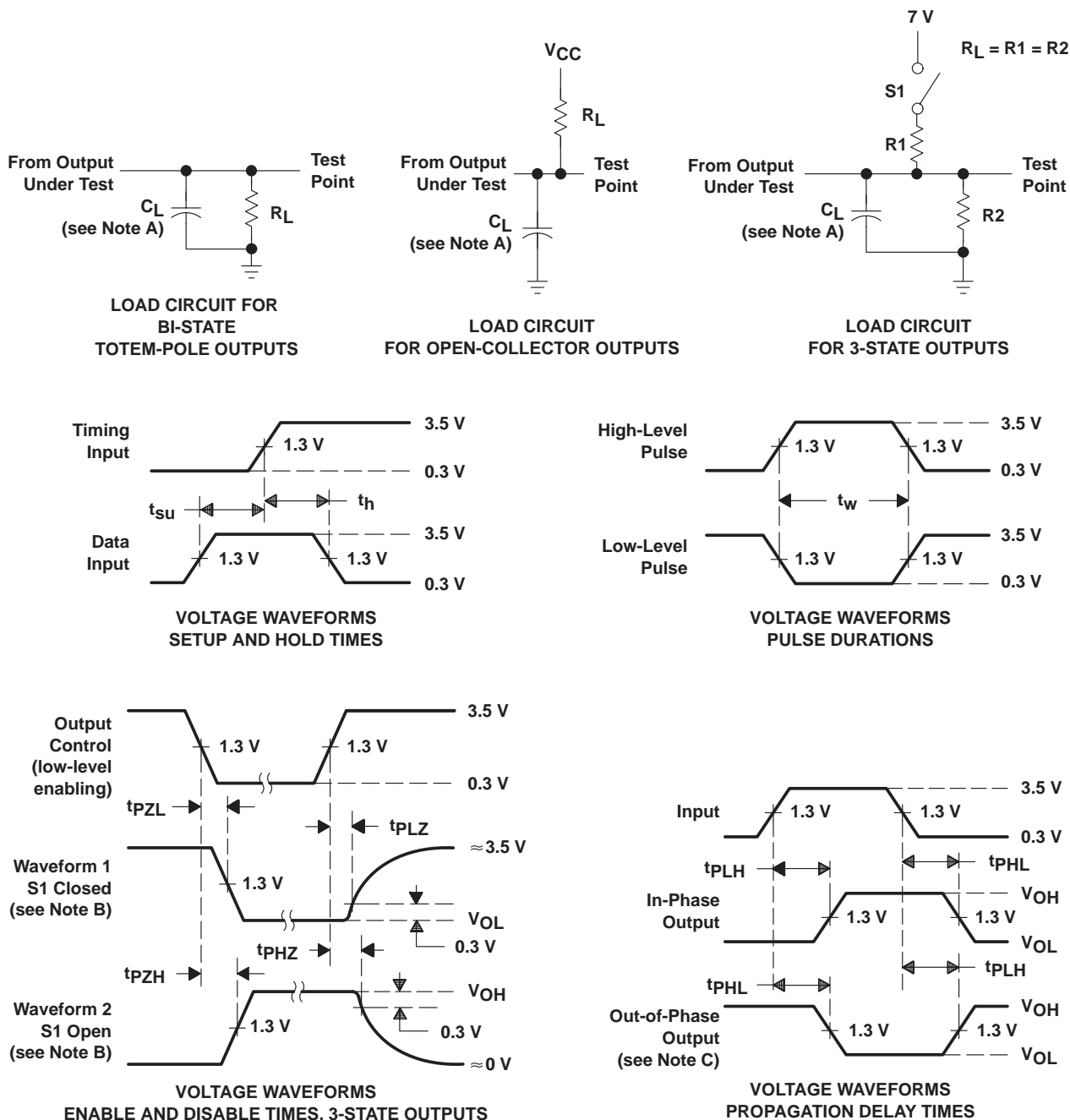

- NOTES: A. C_L includes probe and jig capacitance.
 B. Waveform 1 is for an output with internal conditions such that the output is low except when disabled by the output control. Waveform 2 is for an output with internal conditions such that the output is high except when disabled by the output control.
 C. When measuring propagation delay items of 3-state outputs, switch S1 is open.
 D. All input pulses have the following characteristics: $PRR \leq 1$ MHz, $t_r = t_f = 2$ ns, duty cycle = 50%.
 E. The outputs are measured one at a time with one transition per measurement.

Figure 1. Load Circuits and Voltage Waveforms

IMPORTANT NOTICE

Texas Instruments and its subsidiaries (TI) reserve the right to make changes to their products or to discontinue any product or service without notice, and advise customers to obtain the latest version of relevant information to verify, before placing orders, that information being relied on is current and complete. All products are sold subject to the terms and conditions of sale supplied at the time of order acknowledgement, including those pertaining to warranty, patent infringement, and limitation of liability.

TI warrants performance of its semiconductor products to the specifications applicable at the time of sale in accordance with TI's standard warranty. Testing and other quality control techniques are utilized to the extent TI deems necessary to support this warranty. Specific testing of all parameters of each device is not necessarily performed, except those mandated by government requirements.

CERTAIN APPLICATIONS USING SEMICONDUCTOR PRODUCTS MAY INVOLVE POTENTIAL RISKS OF DEATH, PERSONAL INJURY, OR SEVERE PROPERTY OR ENVIRONMENTAL DAMAGE ("CRITICAL APPLICATIONS"). TI SEMICONDUCTOR PRODUCTS ARE NOT DESIGNED, AUTHORIZED, OR WARRANTED TO BE SUITABLE FOR USE IN LIFE-SUPPORT DEVICES OR SYSTEMS OR OTHER CRITICAL APPLICATIONS. INCLUSION OF TI PRODUCTS IN SUCH APPLICATIONS IS UNDERSTOOD TO BE FULLY AT THE CUSTOMER'S RISK.

In order to minimize risks associated with the customer's applications, adequate design and operating safeguards must be provided by the customer to minimize inherent or procedural hazards.

TI assumes no liability for applications assistance or customer product design. TI does not warrant or represent that any license, either express or implied, is granted under any patent right, copyright, mask work right, or other intellectual property right of TI covering or relating to any combination, machine, or process in which such semiconductor products or services might be or are used. TI's publication of information regarding any third party's products or services does not constitute TI's approval, warranty or endorsement thereof.