

SN64BCT25244

25-Ω OCTAL BUFFER/DRIVER WITH 3-STATE OUTPUTS

SCBS477 – DECEMBER 1992 – REVISED JANUARY 1994

- **State-of-the-Art BiCMOS Design Significantly Reduces I_{CCZ}**
- **High-Impedance State During Power Up and Power Down**
- **ESD Protection Exceeds 2000 V Per MIL-STD-883C, Method 3015; Exceeds 200 V Using Machine Model (C = 200 pF, R = 0)**
- **Designed to Facilitate Incident-Wave Switching for Line Impedances of 25 Ω or Greater**
- **Distributed V_{CC} and GND Pins Minimize Noise Generated by the Simultaneous Switching of Outputs**
- **Package Options Include Plastic Small-Outline (DW) Packages and Standard Plastic 300-mil DIPs (NT)**

DW OR NT PACKAGE
(TOP VIEW)

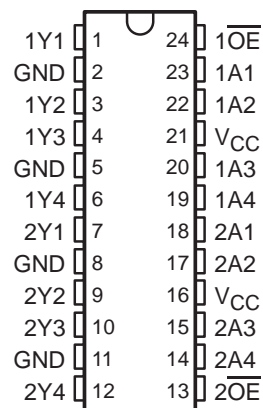

description

The SN64BCT25244 is a 25-Ω octal buffer and line driver designed specifically to improve both the performance and density of 3-state memory address drivers, clock drivers, and bus-oriented transceivers.

When the output-enable ($1\overline{OE}$ and $2\overline{OE}$) inputs are low, the device transmits data from the A inputs to the Y outputs. When $1\overline{OE}$ and $2\overline{OE}$ are high, the outputs are in the high-impedance state.

This buffer/driver is capable of sinking 188-mA I_{OL} , which facilitates switching 25-Ω transmission lines on the incident wave. The distributed V_{CC} and GND pins minimize switching noise for more reliable system operation.

The outputs are in a high-impedance state during power up and power down while the supply voltage value is less than approximately 3 V.

The SN64BCT25244 is characterized for operation from -40°C to 85°C and 0°C to 70°C .

FUNCTION TABLE
(each buffer/driver)

INPUTS		OUTPUT
\overline{OE}	A	Y
L	H	H
L	L	L
H	X	Z

SN64BCT25244

25-Ω OCTAL BUFFER/DRIVER WITH 3-STATE OUTPUTS

SCBS477 – DECEMBER 1992 – REVISED JANUARY 1994

logic symbol†

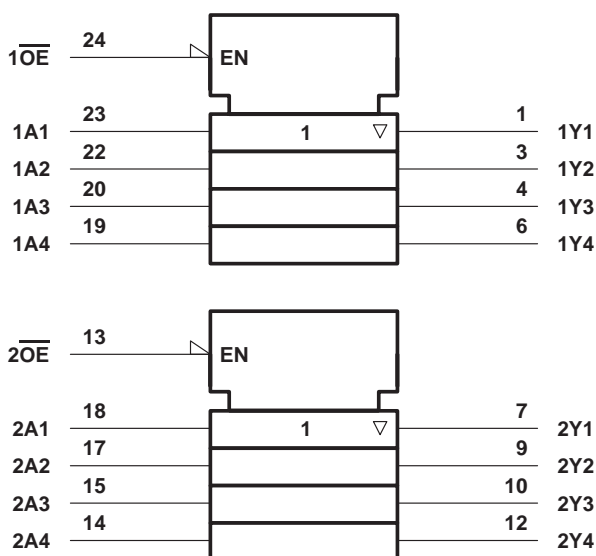

† This symbol is in accordance with ANSI/IEEE Std 91-1984 and IEC Publication 617-12.

logic diagram (positive logic)

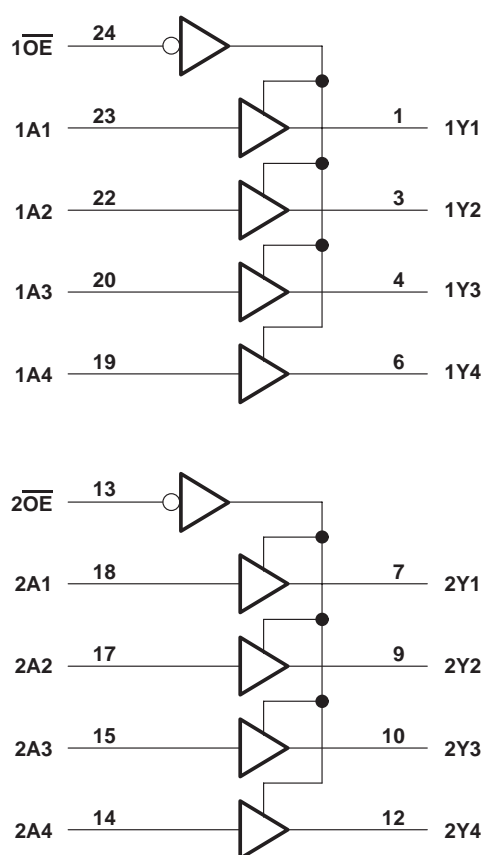

absolute maximum ratings over operating free-air temperature range (unless otherwise noted)‡

Supply voltage range, V_{CC}	-0.5 V to 7 V
Input voltage range, V_I (see Note 1)	-0.5 V to 7 V
Voltage range applied to any output in the disabled or power-off state, V_O	-0.5 V to 5.5 V
Voltage range applied to any output in the high state, V_O	-0.5 V to V_{CC}
Input clamp current, I_{IK} ($V_I < 0$)	-30 mA
Current into any output in the low state, I_O	376 mA
Operating free-air temperature range	-40°C to 85°C
Storage temperature range	-65°C to 150°C

‡ Stresses beyond those listed under "absolute maximum ratings" may cause permanent damage to the device. These are stress ratings only, and functional operation of the device at these or any other conditions beyond those indicated under "recommended operating conditions" is not implied. Exposure to absolute-maximum-rated conditions for extended periods may affect device reliability.

NOTE 1: The input and output negative-voltage ratings may be exceeded if the input and output clamp-current ratings are observed.



POST OFFICE BOX 655303 • DALLAS, TEXAS 75265

SN64BCT25244

25-Ω OCTAL BUFFER/DRIVER WITH 3-STATE OUTPUTS

SCBS477 – DECEMBER 1992 – REVISED JANUARY 1994

recommended operating conditions (see Note 2)

		MIN	NOM	MAX	UNIT
V _{CC}	Supply voltage	4.5	5	5.5	V
V _{IH}	High-level input voltage	2			V
V _{IL}	Low-level input voltage			0.8	V
I _{IK}	Input clamp current			-18	mA
I _{OH}	High-level output current			-80	mA
I _{OL}	Low-level output current			188	mA
T _A	Operating free-air temperature	-40		85	°C

NOTE 2: Unused or floating inputs must be held high or low.

electrical characteristics over recommended operating free-air temperature range (unless otherwise noted)

PARAMETER	TEST CONDITIONS		MIN	TYP†	MAX	UNIT
V _{IK}	V _{CC} = 4.5 V,	I _I = -18 mA			-1.2	V
V _{OH}	V _{CC} = 4.75 V,	I _{OH} = -3 mA	2.7			V
	V _{CC} = 4.5 V,	I _{OH} = -80 mA	2			
V _{OL}	V _{CC} = 4.5 V	I _{OL} = 94 mA	0.42	0.55		V
		I _{OL} = 188 mA		0.7		
I _{OZ}	V _{CC} = 0 to 2.3 V (power up)	V _O = 2.7 V or 0.5 V, \overline{OE} at 0.8 V		±50		μA
	V _{CC} = 2.3 to 0 (power down)			±50		
I _I	V _{CC} = 5.5 V,	V _I = 5.5 V			0.1	mA
I _{IH}	V _{CC} = 5.5 V,	V _I = 2.7 V			20	μA
I _{IL}	V _{CC} = 5.5 V,	V _I = 0.5 V			-0.6	mA
I _{OZH}	V _{CC} = 5.5 V,	V _O = 2.7 V			50	μA
I _{OZL}	V _{CC} = 5.5 V,	V _O = 0.5 V			-50	μA
I _{CCL}	V _{CC} = 5.5 V,	Outputs open		90	119	mA
I _{CCH}	V _{CC} = 5.5 V,	Outputs open		59	78	mA
I _{CCZ}	V _{CC} = 5.5 V,	Outputs open		7	11	mA
C _i	V _{CC} = 5 V,	V _I = 2.5 V or 0.5 V		5.5		pF
C _o	V _{CC} = 5 V,	V _O = 2.5 V or 0.5 V		17		pF

† All typical values are at V_{CC} = 5 V, T_A = 25°C.

switching characteristics over recommended ranges of supply voltage and operating free-air temperature, C_L = 50 pF (unless otherwise noted) (see Note 3)

PARAMETER	FROM (INPUT)	TO (OUTPUT)	V _{CC} = 5 V, T _A = 25°C			T _A = -40°C to 85°C		T _A = 0°C to 70°C		UNIT
			MIN	TYP	MAX	MIN	MAX	MIN	MAX	
t _{PLH}	A	Y	1	3.2	4.9	1	5.6	1	5.5	ns
t _{PHL}			2	4	5.6	2	6.3	2	6	
t _{PZH}	\overline{OE}	Y	3.2	5.6	8.5	3.2	9.7	3.2	9.3	ns
t _{PZL}			3.7	6.3	9.2	3.7	10.4	3.7	10.2	
t _{PHZ}	\overline{OE}	Y	1.6	3.6	5.5	1.6	6.5	1.6	6.3	ns
t _{PLZ}			3.1	5.3	7.8	3.1	9.5	3.1	8.4	

NOTE 3: Load circuits and voltage waveforms are shown in Section 1.



IMPORTANT NOTICE

Texas Instruments and its subsidiaries (TI) reserve the right to make changes to their products or to discontinue any product or service without notice, and advise customers to obtain the latest version of relevant information to verify, before placing orders, that information being relied on is current and complete. All products are sold subject to the terms and conditions of sale supplied at the time of order acknowledgement, including those pertaining to warranty, patent infringement, and limitation of liability.

TI warrants performance of its semiconductor products to the specifications applicable at the time of sale in accordance with TI's standard warranty. Testing and other quality control techniques are utilized to the extent TI deems necessary to support this warranty. Specific testing of all parameters of each device is not necessarily performed, except those mandated by government requirements.

CERTAIN APPLICATIONS USING SEMICONDUCTOR PRODUCTS MAY INVOLVE POTENTIAL RISKS OF DEATH, PERSONAL INJURY, OR SEVERE PROPERTY OR ENVIRONMENTAL DAMAGE ("CRITICAL APPLICATIONS"). TI SEMICONDUCTOR PRODUCTS ARE NOT DESIGNED, AUTHORIZED, OR WARRANTED TO BE SUITABLE FOR USE IN LIFE-SUPPORT DEVICES OR SYSTEMS OR OTHER CRITICAL APPLICATIONS. INCLUSION OF TI PRODUCTS IN SUCH APPLICATIONS IS UNDERSTOOD TO BE FULLY AT THE CUSTOMER'S RISK.

In order to minimize risks associated with the customer's applications, adequate design and operating safeguards must be provided by the customer to minimize inherent or procedural hazards.

TI assumes no liability for applications assistance or customer product design. TI does not warrant or represent that any license, either express or implied, is granted under any patent right, copyright, mask work right, or other intellectual property right of TI covering or relating to any combination, machine, or process in which such semiconductor products or services might be or are used. TI's publication of information regarding any third party's products or services does not constitute TI's approval, warranty or endorsement thereof.