

NE5534, NE5534A, SE5534, SE5534A LOW-NOISE OPERATIONAL AMPLIFIERS

SLOS070 – JULY 1979 – REVISED SEPTEMBER 1990

- **Equivalent Input Noise Voltage**
3.5 nV/ $\sqrt{\text{Hz}}$
- **Unity-Gain Bandwidth . . . 10 MHz Typ**
- **Common-Mode Rejection Ratio**
100 dB Typ
- **High DC Voltage Gain . . . 100 V/mV Typ**
- **Peak-to-Peak Output Voltage Swing**
32 V Typ With $V_{CC\pm} = \pm 18 \text{ V}$ and $R_L = 600 \Omega$
- **High Slew Rate . . . 13 V/ μs Typ**
- **Wide Supply Voltage Range $\pm 3 \text{ V}$ to $\pm 20 \text{ V}$**
- **Low Harmonic Distortion**
- **Designed to Be Interchangeable With**
Signetics NE5534, NE5534A, SE5534,
and SE5534A

description

The NE5534, NE5534A, SE5534, and SE5534A are monolithic high-performance operational amplifiers combining excellent dc and ac characteristics. Some of the features include very low noise, high output drive capability, high unity-gain and maximum-output-swing bandwidths, low distortion, and high slew rate.

These operational amplifiers are internally compensated for a gain equal to or greater than three. Optimization of the frequency response for various applications can be obtained by use of an external compensation capacitor between COMP and COMP/BAL. The devices feature input-protection diodes, output short-circuit protection, and offset-voltage nulling capability.

For the NE5534A, a maximum limit is specified for equivalent input noise voltage.

The NE5534 and NE5534A are characterized for operation from 0°C to 70°C. The SE5534 and SE5534A are characterized for operation over the full military temperature range of -55°C to 125°C.

NE5534, NE5534A . . . D OR P PACKAGE
SE5534, SE5534A . . . JG PACKAGE

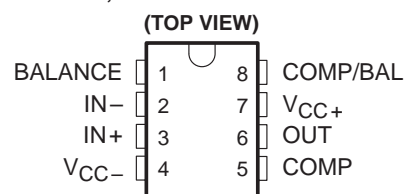

SE5534, SE5534A . . . FK PACKAGE
(TOP VIEW)

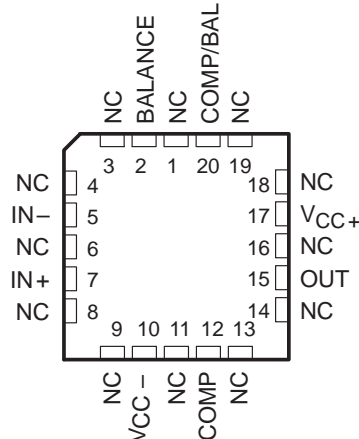

NC – No internal connection

symbol

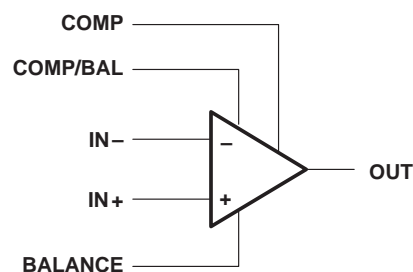

**SE5534A FROM TI NOT RECOMMENDED
FOR NEW DESIGNS**

AVAILABLE OPTIONS

T _A	V _{IO} max AT 25°C	PACKAGE			
		SMALL OUTLINE (D)	CERAMIC (FK)	CERAMIC DIP (JG)	PLASTIC DIP (P)
0°C to 70°C	4 mV	NE5534D NE5534AD	— —	— —	NE5534P NE5534AP
-55°C to 125°C	2 mV	— —	SE5534FK SE5534AFK	SE5534JG SE5534AJG	— —

The D package is available taped and reeled. Add the suffix R to the device type (e.g., NE5534DR).

PRODUCTION DATA information is current as of publication date. Products conform to specifications per the terms of Texas Instruments standard warranty. Production processing does not necessarily include testing of all parameters.

**TEXAS
INSTRUMENTS**

POST OFFICE BOX 655303 • DALLAS, TEXAS 75265

Copyright © 1990, Texas Instruments Incorporated

NE5534, NE5534A, SE5534, SE5534A LOW-NOISE OPERATIONAL AMPLIFIERS

SLOS070 – JULY 1979 – REVISED SEPTEMBER 1990

schematic

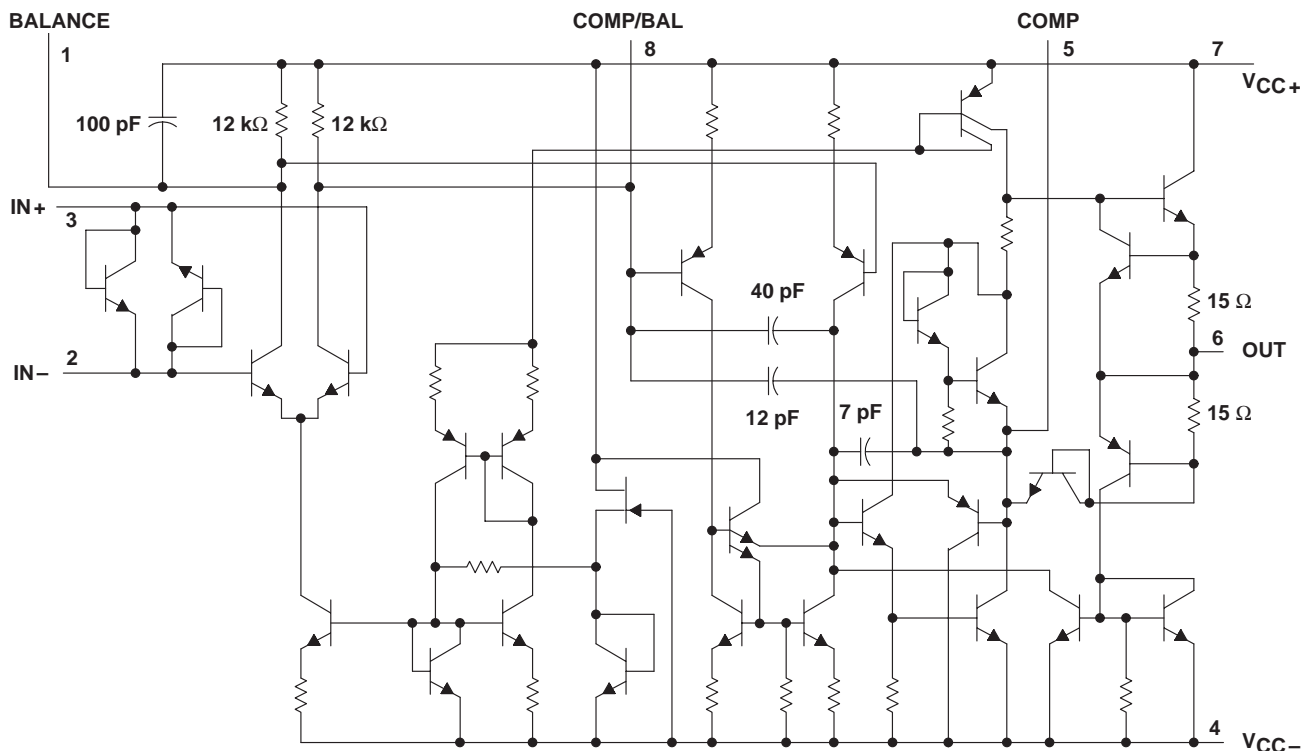

All component values shown are nominal.
Pin numbers shown are for D, JG, and P packages.

absolute maximum ratings over operating free-air temperature range (unless otherwise noted)

Supply voltage, V_{CC+} (see Note 1)	22 V
Supply voltage, V_{CC-} (see Note 1)	-22 V
Input voltage either input (see Notes 1 and 2)	V_{CC+}
Input current (see Note 3)	± 10 mA
Duration of output short circuit (see Note 4)	unlimited
Continuous total power dissipation	See Dissipation Rating Table
Operating free-air temperature range:	
NE5534, NE5534A	0°C to 70°C
SE5534, SE5534A	-55°C to 125°C
Storage temperature range	-65°C to 150°C
Case temperature for 60 seconds: FK package	260°C
Lead temperature range 1,6 mm (1/16 inch) from case for 60 seconds: JG package	300°C
Lead temperature range 1,6 mm (1/16 inch) from case for 10 seconds: D or P package	260°C

- NOTES:
1. All voltage values, except differential voltages, are with respect to the midpoint between V_{CC+} and V_{CC-} .
 2. The magnitude of the input voltage must never exceed the magnitude of the supply voltage.
 3. Excessive current will flow if a differential input voltage in excess of approximately 0.6 V is applied between the inputs unless some limiting resistance is used.
 4. The output may be shorted to ground or to either power supply. Temperature and/or supply voltages must be limited to ensure the maximum dissipation rating is not exceeded.



POST OFFICE BOX 655303 • DALLAS, TEXAS 75265

NE5534, NE5534A, SE5534, SE5534A LOW-NOISE OPERATIONAL AMPLIFIERS

SLOS070 – JULY 1979 – REVISED SEPTEMBER 1990

DISSIPATION RATING TABLE

PACKAGE	$T_A \leq 25^\circ\text{C}$	DERATING FACTOR ABOVE $T_A = 25^\circ\text{C}$	$T_A = 70^\circ\text{C}$	$T_A = 125^\circ\text{C}$
	POWER RATING		POWER RATING	POWER RATING
D	725 mW	5.8 mW/°C	464 mW	N/A
FK (see Note 5)	1375 mW	11.0 mW/°C	880 mW	275 mW
JG	1050 mW	8.4 mW/°C	672 mW	210 mW
P	1000 mW	8.0 mW/°C	640 mW	N/A

NOTE 5: For the FK package, power rating and derating factor will vary with actual mounting technique used. The values stated here are believed to be conservative.

recommended operating conditions

	MIN	NOM	MAX	UNIT
Supply voltage, V_{CC+}	5		15	V
Supply voltage, V_{CC-}	-5		-15	V

electrical characteristics, $V_{CC} \pm = \pm 15\text{ V}$, $T_A = 25^\circ\text{C}$ (unless otherwise noted)

PARAMETER	TEST CONDITION [†]	NE5534, NE5534A			SE5534, SE5534A			UNIT
		MIN	TYP	MAX	MIN	TYP	MAX	
V_{IO} Input offset voltage	$V_O = 0$, $R_S = 50\ \Omega$	$T_A = 25^\circ\text{C}$	0.5	4	0.5	2	mV	
		$T_A = \text{Full range}$		5		3		
I_{IO} Input offset current	$V_O = 0$	$T_A = 25^\circ\text{C}$	20	300	10	200	nA	
		$T_A = \text{Full range}$		400		500		
I_{IB} Input bias current	$V_O = 0$	$T_A = 25^\circ\text{C}$	500	1500	400	800	nA	
		$T_A = \text{Full range}$		2000		1500		
V_{ICR} Common-mode input voltage range		± 12	± 13	± 12	± 13	V		
$V_{O(PP)}$ Maximum peak-to-peak output voltage swing	$R_L \geq 600\ \Omega$	$V_{CC\pm} = \pm 15\text{ V}$	24	26	24	26	V	
		$V_{CC\pm} = \pm 18\text{ V}$	30	32	30	32		
A_{VD} Large-signal differential voltage amplification	$V_O = \pm 10\text{ V}$, $R_L \geq 600\ \Omega$	$T_A = 25^\circ\text{C}$	25	100	50	100	V/mV	
		$T_A = \text{Full range}$	15		25			
A_{vd} Small-signal differential voltage amplification	$f = 10\text{ kHz}$	$C_C = 0$		6		6	V/mV	
		$C_C = 22\text{ pF}$		2.2		2.2		
B_{OM} Maximum-output-swing bandwidth	$V_O = \pm 10\text{ V}$, $C_C = 0$		200		200	kHz		
	$V_O = \pm 10\text{ V}$, $C_C = 22\text{ pF}$		95		95			
	$V_{CC\pm} = \pm 18\text{ V}$, $V_O = \pm 14\text{ V}$, $R_L \geq 600\ \Omega$, $C_C = 22\text{ pF}$		70		70			
B_1 Unity-gain bandwidth	$C_C = 22\text{ pF}$, $C_L = 100\text{ pF}$		10		10	MHz		
r_i Input resistance		30	100	50	100	k Ω		
z_o Output impedance	$A_{VD} = 30\text{ dB}$, $C_C = 22\text{ pF}$, $R_L \geq 600\ \Omega$, $f = 10\text{ kHz}$		0.3		0.3	Ω		
CMRR Common-mode rejection ratio	$V_O = 0$, $R_S = 50\ \Omega$	$V_{IC} = V_{ICRmin}$	70	100	80	100	dB	
k_{SVR} Supply voltage rejection ratio ($\Delta V_{CC}/\Delta V_{IO}$)	$V_{CC+} = \pm 9\text{ V to } \pm 15\text{ V}$, $V_O = 0$, $R_S = 50\ \Omega$		80	100	86	100	dB	
I_{OS} Output short-circuit current			38		38	mA		
I_{CC} Supply current	$V_O = 0$, No load	$T_A = 25^\circ\text{C}$	4	8	4	6.5	mA	
		$T_A = \text{Full range}$				9		

[†] All characteristics are measured under open-loop conditions with zero common-mode input voltage unless otherwise specified. Full range is $T_A = 0^\circ\text{C}$ to 70°C for NE5534 and NE5534A and -55°C to 125°C for SE5534 and SE5534A.



NE5534, NE5534A, SE5534, SE5534A LOW-NOISE OPERATIONAL AMPLIFIERS

SLOS070 – JULY 1979 – REVISED SEPTEMBER 1990

operating characteristics, $V_{CC} \pm = \pm 15\text{ V}$, $T_A = 25^\circ\text{C}$

PARAMETER	TEST CONDITIONS	SE5534, NE5534			SE5534A, NE5534A			UNIT
		MIN	TYP	MAX	MIN	TYP	MAX	
SR Slew rate at unity gain	$C_C = 0$	13			13			V/ μs
	$C_C = 22\text{ pF}$	6			6			
t_r Rise time	$V_I = 50\text{ mV}$, $A_{VD} = 1$, $R_L = 600\ \Omega$, $C_C = 22\text{ pF}$, $C_L = 100\text{ pF}$	20			20			ns
Overshoot factor		20%			20%			
t_r Rise time	$V_I = 50\text{ mV}$, $A_{VD} = 1$, $R_L = 600\ \Omega$, $C_C = 47\text{ pF}$, $C_L = 500\text{ pF}$	50			50			ns
Overshoot factor		35%			35%			
V_n Equivalent input noise voltage	$f = 30\text{ Hz}$	7			5.5	7		nV/ $\sqrt{\text{Hz}}$
	$f = 1\text{ kHz}$	4			3.5	4.5		
I_n Equivalent input noise current	$f = 30\text{ Hz}$	2.5			1.5			pA/ $\sqrt{\text{Hz}}$
	$f = 1\text{ kHz}$	0.6			0.4			
\bar{F} Average noise figure	$R_S = 5\text{ k}\Omega$, $f = 10\text{ Hz to } 20\text{ kHz}$				0.9			dB

TYPICAL CHARACTERISTICS†

NORMALIZED INPUT BIAS CURRENT
AND INPUT OFFSET CURRENT
vs
FREE-AIR TEMPERATURE

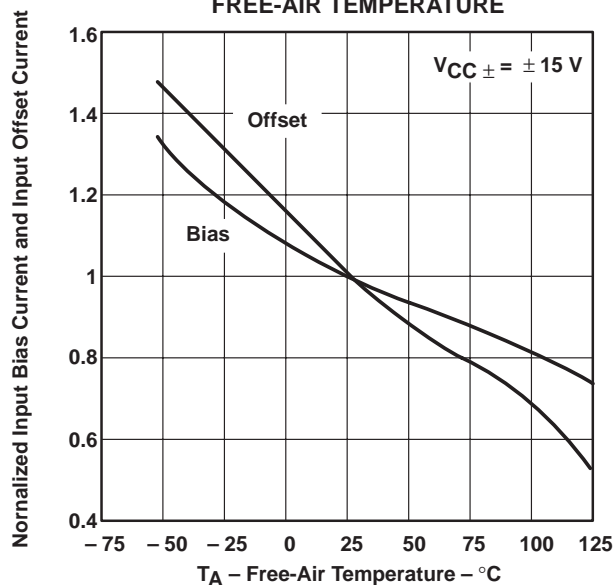

Figure 1

MAXIMUM PEAK-TO-PEAK OUTPUT VOLTAGE
vs
FREQUENCY

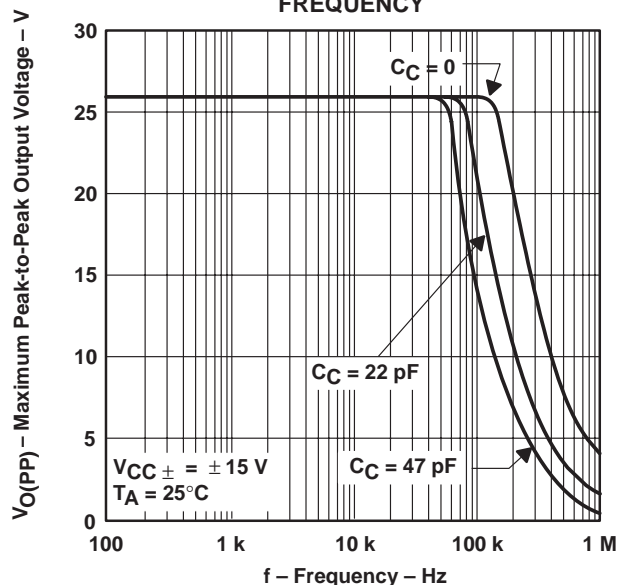
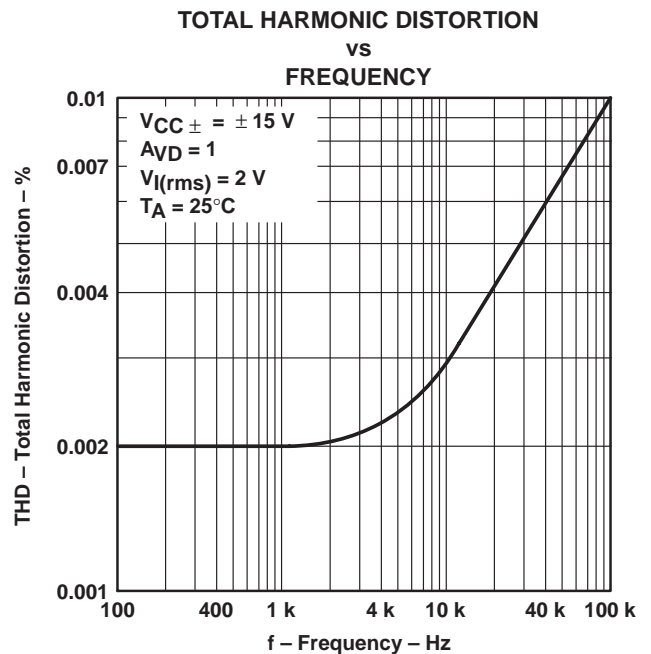
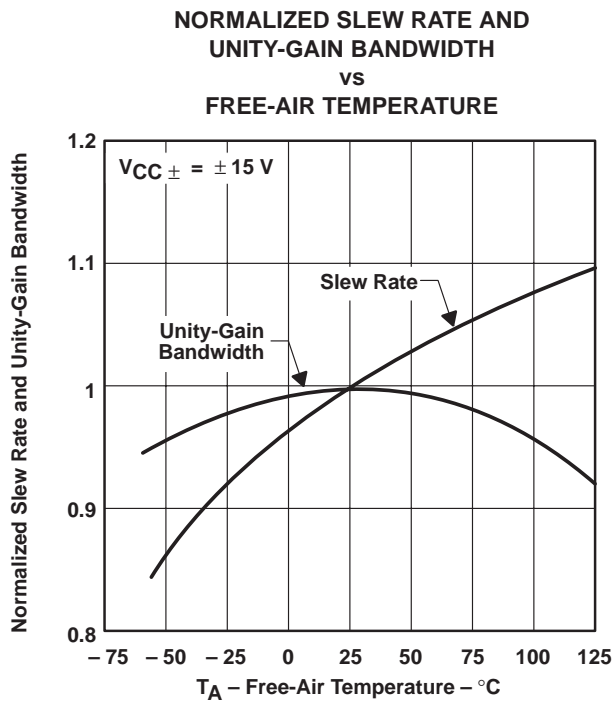
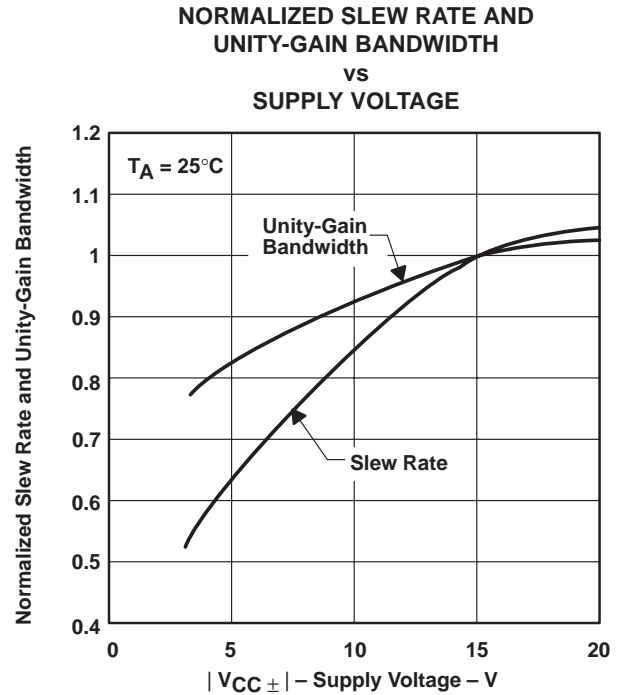
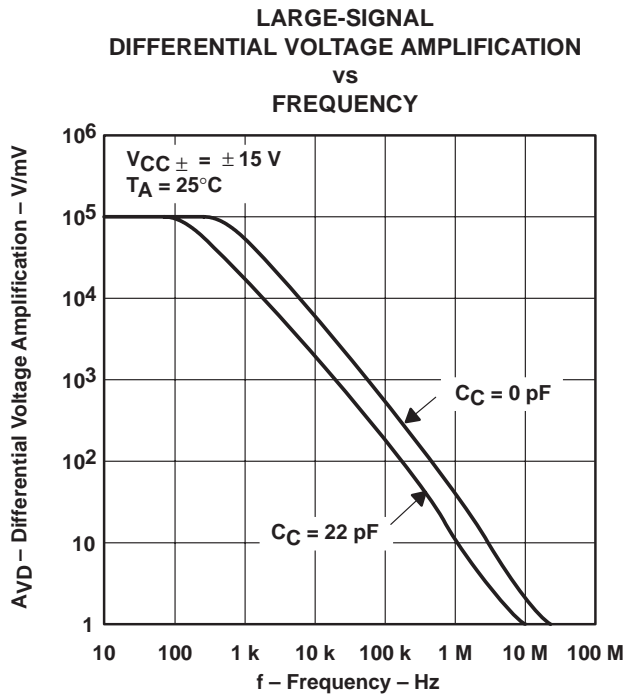

Figure 2

† Data at high and low temperatures are applicable only within the rated operating free-air temperature ranges of the various devices.

TYPICAL CHARACTERISTICS†



† Data at high and low temperatures are applicable only within the rated operating free-air temperature ranges of the various devices.

NE5534, NE5534A, SE5534, SE5534A LOW-NOISE OPERATIONAL AMPLIFIERS

SLOS070 – JULY 1979 – REVISED SEPTEMBER 1990

TYPICAL CHARACTERISTICS

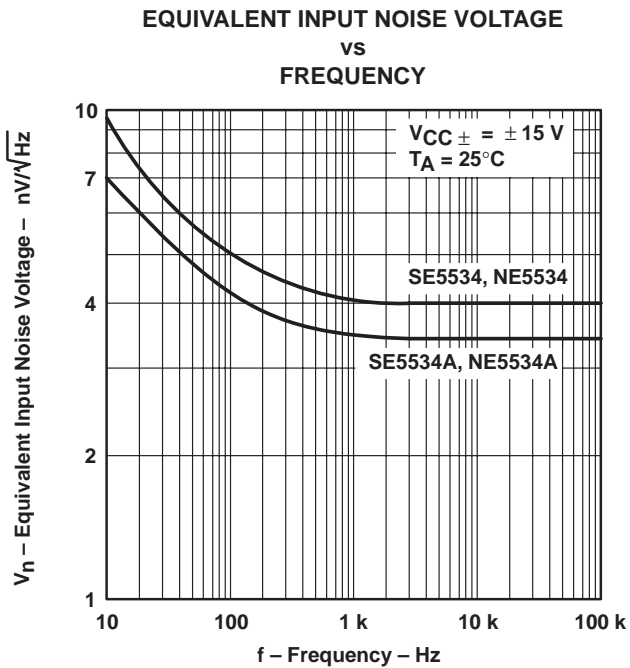

Figure 7

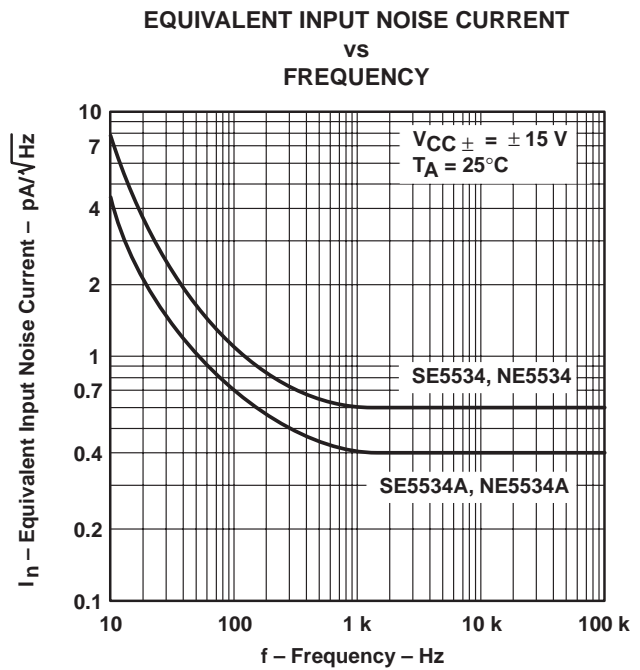

Figure 8

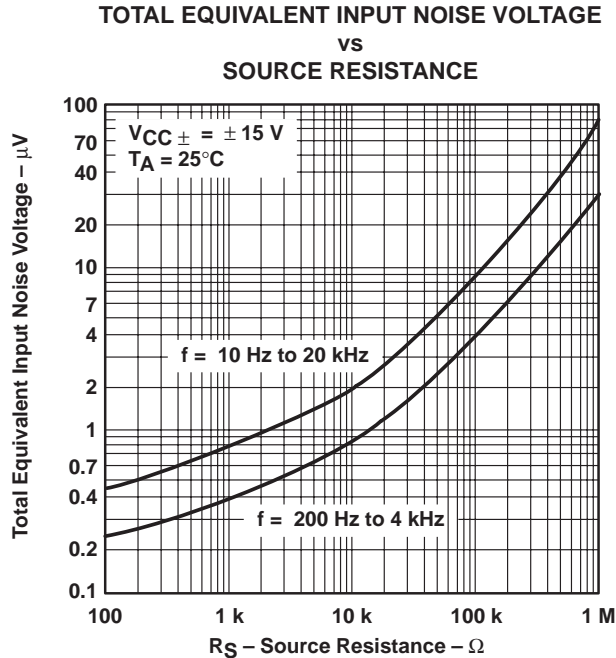

Figure 9



IMPORTANT NOTICE

Texas Instruments and its subsidiaries (TI) reserve the right to make changes to their products or to discontinue any product or service without notice, and advise customers to obtain the latest version of relevant information to verify, before placing orders, that information being relied on is current and complete. All products are sold subject to the terms and conditions of sale supplied at the time of order acknowledgement, including those pertaining to warranty, patent infringement, and limitation of liability.

TI warrants performance of its semiconductor products to the specifications applicable at the time of sale in accordance with TI's standard warranty. Testing and other quality control techniques are utilized to the extent TI deems necessary to support this warranty. Specific testing of all parameters of each device is not necessarily performed, except those mandated by government requirements.

CERTAIN APPLICATIONS USING SEMICONDUCTOR PRODUCTS MAY INVOLVE POTENTIAL RISKS OF DEATH, PERSONAL INJURY, OR SEVERE PROPERTY OR ENVIRONMENTAL DAMAGE ("CRITICAL APPLICATIONS"). TI SEMICONDUCTOR PRODUCTS ARE NOT DESIGNED, AUTHORIZED, OR WARRANTED TO BE SUITABLE FOR USE IN LIFE-SUPPORT DEVICES OR SYSTEMS OR OTHER CRITICAL APPLICATIONS. INCLUSION OF TI PRODUCTS IN SUCH APPLICATIONS IS UNDERSTOOD TO BE FULLY AT THE CUSTOMER'S RISK.

In order to minimize risks associated with the customer's applications, adequate design and operating safeguards must be provided by the customer to minimize inherent or procedural hazards.

TI assumes no liability for applications assistance or customer product design. TI does not warrant or represent that any license, either express or implied, is granted under any patent right, copyright, mask work right, or other intellectual property right of TI covering or relating to any combination, machine, or process in which such semiconductor products or services might be or are used. TI's publication of information regarding any third party's products or services does not constitute TI's approval, warranty or endorsement thereof.