

# TLC354

## LinCMOS™ QUADRUPLE DIFFERENTIAL COMPARATORS

SLCS116B – SEPTEMBER 1985 – REVISED FEBRUARY 1997

- **Single- or Dual-Supply Operation**
- **Wide Range of Supply Voltages**  
1.4 V to 18 V
- **Very Low Supply Current Drain**  
300  $\mu$ A Typ at 5 V  
130  $\mu$ A Typ at 1.4 V
- **Built-In ESD Protection**
- **High Input Impedance . . .  $10^{12} \Omega$  Typ**
- **Extremely Low Input Bias Current**  
5 pA Typ
- **Ultrastable Low Input Offset Voltage**
- **Input Offset Voltage Change at Worst-Case Input Conditions Typically 0.23  $\mu$ V/Month, Including the First 30 Days**
- **Common-Mode Input Voltage Range Includes Ground**
- **Outputs Compatible With TTL, MOS, and CMOS**
- **Pin-Compatible With LM339**

D, N, OR PW PACKAGE  
(TOP VIEW)

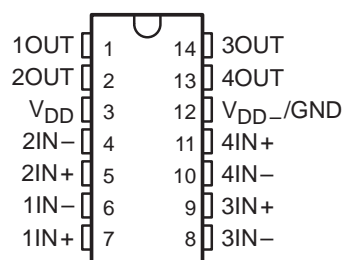

symbol (each comparator)



### description

This device is fabricated using LinCMOS™ technology and consists of four independent differential voltage comparators; each is designed to operate from a single power supply. Operation from dual supplies is also possible if the difference between the two supplies is 1.4 V to 18 V. Each device features extremely high input impedance (typically greater than  $10^{12} \Omega$ ), which allows direct interface to high-impedance sources. The outputs are n-channel open-drain configurations and can be connected to achieve positive-logic wired-AND relationships. The capability of the TLC354 to operate from a 1.4-V supply makes this device ideal for low-voltage battery applications.

The TLC354 has internal electrostatic discharge (ESD) protection circuits and has been classified with a 2000-V ESD rating tested under MIL-STD-883C, Method 3015. However, care should be exercised in handling this device as exposure to ESD may result in degradation of the device parametric performance.

The TLC354C is characterized for operation from 0°C to 70°C. The TLC354I is characterized for operation over the industrial temperature range of -40°C to 85°C. The TLC354M is characterized for operation over the full military temperature range -55°C to 125°C.

#### AVAILABLE OPTIONS

T <sub>A</sub>	V <sub>IO</sub> max AT 25°C	PACKAGED DEVICES			CHIP FORM (Y)
		SMALL OUTLINE (D)	PLASTIC DIP (P)	TSSOP (PW)	
0°C to 70°C	5 mV	TLC354CD	TLC354CN	TLC354CPW	TLC354Y
-40°C to 85°C	5 mV	TLC354ID	TLC354IN	—	—
-55°C to 125°C	5 mV	TLC354MD	TLC354MN	—	—

The D packages are available taped and reeled. Add R suffix to device type (e.g., TLC354CDR).



Please be aware that an important notice concerning availability, standard warranty, and use in critical applications of Texas Instruments semiconductor products and disclaimers thereto appears at the end of this data sheet.

LinCMOS is a trademark of Texas Instruments Incorporated.

PRODUCTION DATA information is current as of publication date. Products conform to specifications per the terms of Texas Instruments standard warranty. Production processing does not necessarily include testing of all parameters.

**TEXAS  
INSTRUMENTS**

POST OFFICE BOX 655303 • DALLAS, TEXAS 75265

Copyright © 1997, Texas Instruments Incorporated

# TLC354 LinCMOS™ QUADRUPLE DIFFERENTIAL COMPARATORS

SLCS116B – SEPTEMBER 1985 – REVISED FEBRUARY 1997

## equivalent schematic (each comparator)

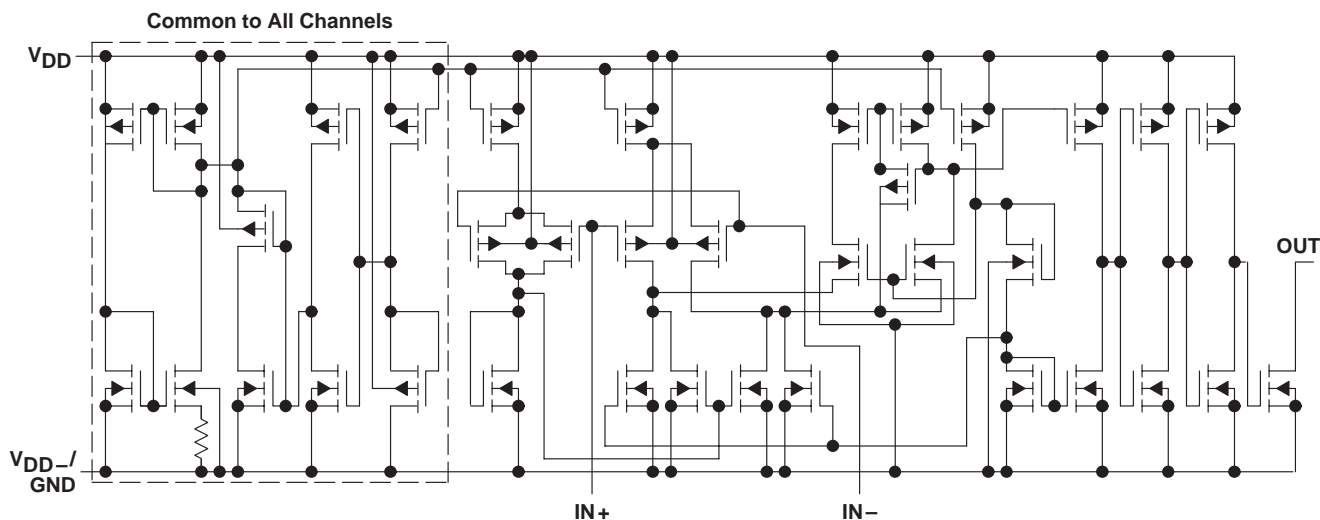

## absolute maximum ratings over operating free-air temperature (unless otherwise noted)†

Supply voltage, $V_{DD}$ (see Note 1)	18 V
Differential input voltage, $V_{ID}$ (see Note 2)	$\pm 18$ V
Input voltage, $V_I$	$V_{DD}$
Input voltage range, $V_I$	-0.3 V to 18 V
Output voltage, $V_O$	18 V
Input current, $I_I$	$\pm 5$ mA
Output current, $I_O$	20 mA
Duration of output short circuit to ground (see Note 3)	Unlimited
Continuous total dissipation	See Dissipation Rating Table
Operating free-air temperature range, $T_A$ : TLC354C	0°C to 70°C
TLC354I	-40°C to 85°C
TLC354M	-55°C to 125°C
Storage temperature range	-65°C to 150°C
Lead temperature 1,6 mm (1/16 inch) from case for 10 seconds	260°C

† Stresses beyond those listed under "absolute maximum ratings" may cause permanent damage to the device. These are stress ratings only, and functional operation of the device at these or any other conditions beyond those indicated under "recommended operating conditions" is not implied. Exposure to absolute-maximum-rated conditions for extended periods may affect device reliability.

- NOTES: 1. All voltage values except differential voltages are with respect to network ground.  
 2. Differential voltages are at IN+ with respect to IN-.  
 3. Short circuits from outputs to  $V_{DD}$  can cause excessive heating and eventual device destruction.

DISSIPATION RATING TABLE

PACKAGE	$T_A \leq 25^\circ\text{C}$ POWER RATING	DERATING FACTOR	DERATE ABOVE $T_A$	$T_A = 70^\circ\text{C}$ POWER RATING	$T_A = 85^\circ\text{C}$ POWER RATING	$T_A = 125^\circ\text{C}$ POWER RATING
D	500 mW	7.6 mW/°C	84°C	500 mW	494 mW	190 mW
N	500 mW	9.2 mW/°C	96°C	500 mW	500 mW	230 mW
PW	700 mW	5.6 mW/°C	25°C	448 mW	N/A	N/A



POST OFFICE BOX 655303 • DALLAS, TEXAS 75265

# TLC354

## LinCMOS™ QUADRUPLE DIFFERENTIAL COMPARATORS

SLCS116B – SEPTEMBER 1985 – REVISED FEBRUARY 1997

### TLC364Y chip information

This chip, when properly assembled, displays characteristics similar to the TLC354C. Thermal compression or ultrasonic bonding can be used on the doped-aluminum bonding pads. Chips can be mounted with conductive epoxy or a gold-silicon preform.

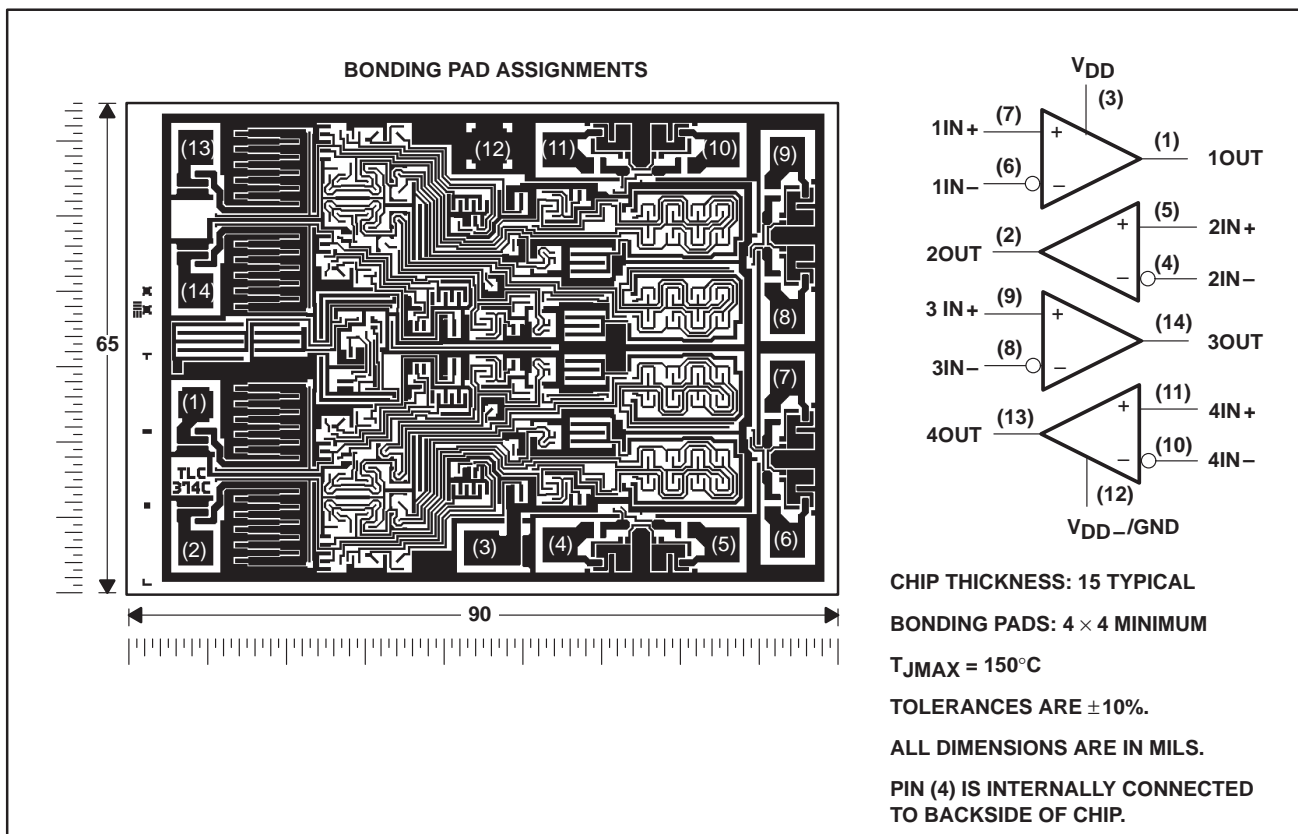

recommended operating conditions

		TLC354C		TLC354I		TLC354M		UNIT
		MIN	MAX	MIN	MAX	MIN	MAX	
Supply voltage, $V_{DD}$		1.4	16	1.4	16	1.4	16	V
Common-mode input voltage, $V_{IC}$	$V_{DD} = 1.4$ V	0	0.2	0	0.2	0	0.2	V
	$V_{DD} = 5$ V	0	3.5	0	3.5	0	3.5	
	$V_{DD} = 10$ V	0	8.5	0	8.5	0	8.5	
Operating free-air temperature, $T_A$		0	70	-40	85	-55	125	°C

electrical characteristics at specified free-air temperature,  $V_{DD} = 1.4$  V

PARAMETER	TEST CONDITIONS	$T_A$ †	TLC354C			TLC354I			TLC354M			UNIT
			MIN	TYP	MAX	MIN	TYP	MAX	MIN	TYP	MAX	
$V_{IO}$ Input offset voltage	$V_{IC} = V_{ICRmin}$ , See Note 4	25°C	2 5			2 5			2 5			mV
		Full range	6.5			7			10			
$I_{IO}$ Input offset current		25°C	1			1			1			pA
		MAX	0.3			1			10			nA
$I_{IB}$ Input bias current		25°C	5			5			5			pA
		MAX	0.6			2			20			nA
$V_{ICR}$ Common-mode input voltage range		25°C	0 to 0.2			0 to 0.2			0 to 0.2			V
$I_{OH}$ High-level output current	$V_{ID} = 1$ V	$V_{OH} = 5$ V	25°C 0.1			0.1			0.1			nA
		$V_{OH} = 15$ V	Full range 1			1			1			μA
$V_{OL}$ Low-level output voltage	$V_{ID} = -0.5$ V, $I_{OL} = 0.6$ mA	25°C	100 200			100 200			100 200			mV
		Full range	200			200			200			
$I_{OL}$ Low-level output current	$V_{ID} = -0.5$ V, $V_{OL} = 300$ mV	25°C	1	1.6		1	1.6		1	1.6		mA
		Full range	400			400			400			μA
$I_{DD}$ Supply current (four comparators)	$V_{ID} = 0.5$ V, No load	25°C	130 300			130 300			130 300			μA
		Full range	400			400			400			

† All characteristics are measured with zero common-mode input voltage unless otherwise noted. Full range is 0°C to 70°C for TLC354C, -40°C to 85°C for TLC354I, and -55°C to 125°C for the TLC354M. MAX is 70°C for TLC354C, 85°C TLC354I, and 125°C for the TLC354M. IMPORTANT: See Parameter Measurement Information.

NOTE 4: The offset voltage limits given are the maximum values required to drive the output above 1.25 V or below 150 mV with a 10-kΩ resistor between the output and  $V_{DD}$ . They can be verified by applying the limit value to the input and checking for the appropriate output state.

**electrical characteristics at specified free-air temperature,  $V_{DD} = 5\text{ V}$**

PARAMETER	TEST CONDITIONS	$T_A$ †	TLC354C			TLC354I			TLC354M			UNIT	
			MIN	TYP	MAX	MIN	TYP	MAX	MIN	TYP	MAX		
$V_{IO}$ Input offset voltage	$V_{IC} = V_{ICRmin}$ , See Note 5	25°C		2	5		2	5		2	5	mV	
		Full range			6.5			7			10		
$I_{IO}$ Input offset current		25°C		1			1			1		pA	
		MAX			0.3			1			10	nA	
$I_{IB}$ Input bias current		25°C		5			5			5		pA	
		MAX			0.6			2			20	nA	
$V_{ICR}$ Common-mode input voltage range		25°C	0 to $V_{DD}-1$			0 to $V_{DD}-1$			0 to $V_{DD}-1$			V	
		Full range	0 to $V_{DD}-1.5$			0 to $V_{DD}-1.5$			0 to $V_{DD}-1.5$				
$I_{OH}$ High-level output current	$V_{ID} = 1\text{ V}$	$V_{OH} = 5\text{ V}$	25°C	0.1			0.1			0.1			nA
		$V_{OH} = 15\text{ V}$	Full range				1			1			$\mu\text{A}$
$V_{OL}$ Low-level output voltage	$V_{ID} = -1\text{ V}$ , $I_{OL} = 4\text{ mA}$	25°C	150			150			150			mV	
		Full range	700			700			700				
$I_{OL}$ Low-level output current	$V_{ID} = -1\text{ V}$ , $V_{OL} = 1.5\text{ mV}$	25°C	6	16		6	16		6	16		mA	
$I_{DD}$ Supply current (four comparators)	$V_{ID} = 1\text{ V}$ , No load	25°C	0.3			0.3			0.3			mA	
		Full range	0.8			0.8			0.8				

† All characteristics are measured with zero common-mode input voltage unless otherwise noted. Full range is 0°C to 70°C for TLC354C, -40°C to 85°C for TLC354I, and -55°C to 125°C for the TLC354M. MAX is 70°C for TLC354C, 85°C TLC354I, and 125°C for the TLC354M. IMPORTANT: See Parameter Measurement Information.

NOTE 5: The offset voltage limits given are the maximum values required to drive the output above 4 V or below 400 mV with a 10-k $\Omega$  resistor between the output and  $V_{DD}$ . They can be verified by applying the limit value to the input and checking for the appropriate output state.

**switching characteristics,  $V_{DD} = 5\text{ V}$ ,  $T_A = 25^\circ\text{C}$**

PARAMETER	TEST CONDITIONS	TLC354C, TLC354I TLC354M			UNIT
		MIN	TYP	MAX	
Response time	$R_L$ connected to 5 V through 5.1 k $\Omega$ , $C_L = 15\text{ pF}$ ‡, See Note 6	100-mV input step with 5-mV overdrive			650
		TTL-level input step			200

‡  $C_L$  includes probe and jig capacitance.

NOTE 6: The response time specified is the interval between the input step function and the instant when the output crosses 1.4 V.

# TLC354

## LinCMOS™ QUADRUPLE DIFFERENTIAL COMPARATORS

SLCS116B – SEPTEMBER 1985 – REVISED FEBRUARY 1997

**electrical characteristics at specified free-air temperature,  $V_{DD} = 1.4\text{ V}$ ,  $T_A = 25^\circ\text{C}$  (unless otherwise noted)**

PARAMETER	TEST CONDITIONS	TLC354Y			UNIT
		MIN	TYP	MAX	
$V_{IO}$ Input offset voltage	$V_{IC} = V_{ICR}$ min, See Note 4		2	5	mV
$I_{IO}$ Input offset current			1		pA
$I_{IB}$ Input bias current			5		pA
$V_{ICR}$ Common-mode input voltage range		0 to 0.2			V
$I_{OH}$ High-level output current	$V_{ID} = 1\text{ V}$ , $V_{OH} = 5\text{ V}$		0.1		nA
$V_{OL}$ Low-level output voltage	$V_{ID} = -0.5\text{ V}$ , $I_{OL} = 0.6\text{ mA}$		100	200	mV
$I_{OL}$ Low-level output current	$V_{ID} = -0.5\text{ V}$ , $V_{OL} = 300\text{ mV}$	1	1.6		mA
$I_{DD}$ Supply current (four comparators)	$V_{ID} = 0.5\text{ V}$ , No load		130	300	$\mu\text{A}$

NOTE 4: The offset voltage limits given are the maximum values required to drive the output above 1.25 V or below 150 mV with a 10-k $\Omega$  resistor between the output and  $V_{DD}$ . They can be verified by applying the limit value to the input and checking for the appropriate output state.

**electrical characteristics at specified free-air temperature,  $V_{DD} = 5\text{ V}$ ,  $T_A = 25^\circ\text{C}$  (unless otherwise noted)**

PARAMETER	TEST CONDITIONS	TLC354Y			UNIT
		MIN	TYP	MAX	
$V_{IO}$ Input offset voltage	$V_{IC} = V_{ICR}$ min, See Note 5		2	5	mV
$I_{IO}$ Input offset current			1		pA
$I_{IB}$ Input bias current			5		pA
$V_{ICR}$ Common-mode input voltage range		0 to $V_{DD}-1$			V
$I_{OH}$ High-level output current	$V_{ID} = 1\text{ V}$ , $V_{OH} = 5\text{ V}$		0.1		nA
$V_{OL}$ Low-level output voltage	$V_{ID} = -1\text{ V}$ , $I_{OL} = 4\text{ mA}$		150	400	mV
$I_{OL}$ Low-level output current	$V_{ID} = -1\text{ V}$ , $V_{OL} = 1.5\text{ mV}$	6	16		mA
$I_{DD}$ Supply current (four comparators)	$V_{ID} = 1\text{ V}$ , No load		0.3	0.6	mA

NOTE 5: The offset voltage limits given are the maximum values required to drive the output above 4 V or below 400 mV with a 10-k $\Omega$  resistor between the output and  $V_{DD}$ . They can be verified by applying the limit value to the input and checking for the appropriate output state.

**switching characteristics,  $V_{DD} = 5\text{ V}$ ,  $T_A = 25^\circ\text{C}$**

PARAMETER	TEST CONDITIONS		TLC354Y			UNIT
			MIN	TYP	MAX	
Response time	$R_L$ connected to 5 V through 5.1 k $\Omega$ , $C_L = 15\text{ pF}$ ‡, See Note 6	100-mV input step with 5-mV overdrive		650		ns
		TTL-level input step		200		

‡  $C_L$  includes probe and jig capacitance.

NOTE 6: The response time specified is the interval between the input step function and the instant when the output crosses 1.4 V.



### PARAMETER MEASUREMENT INFORMATION

The digital output stage of the TLC354 can be damaged if it is held in the linear region of the transfer curve. Conventional operational amplifier/comparator testing incorporates the use of a servo loop that is designed to force the device output to a level within this linear region. Since the servo-loop method of testing cannot be used, the following alternative for measuring parameters such as input offset voltage, common-mode rejection, etc., are offered.

To verify that the input offset voltage falls within the limits specified, the limit value is applied to the input as shown in Figure 1(a). With the noninverting input positive with respect to the inverting input, the output should be high. With the input polarity reversed, the output should be low.

A similar test can be made to verify the input offset voltage at the common-mode extremes. The supply voltages can be slewed as shown in Figure 1(b) for the  $V_{ICR}$  test, rather than changing the input voltages, to provide greater accuracy.

A close approximation of the input offset voltage can be obtained by using a binary search method to vary the differential input voltage while monitoring the output state. When the applied input voltage differential is equal but opposite in polarity to the input offset voltage, the output changes state.

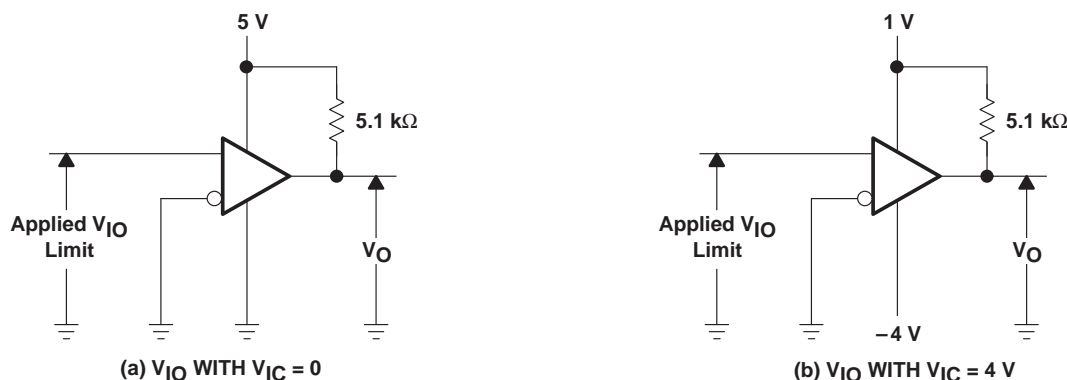

**Figure 1. Method for Verifying That Input Offset Voltage is Within Specified Limits**

# TLC354 LinCMOS™ QUADRUPLE DIFFERENTIAL COMPARATORS

SLCS116B – SEPTEMBER 1985 – REVISED FEBRUARY 1997

## PARAMETER MEASUREMENT INFORMATION

Figure 2 illustrates a practical circuit for direct dc measurement of input offset voltage that does not bias the comparator into the linear region. The circuit consists of a switching-mode servo loop in which U1a generates a triangular waveform of approximately 20-mV amplitude. U1b acts as a buffer with C2 and R4 removing any residual dc offset. The signal is then applied to the inverting input of the comparator under test, while the noninverting input is driven by the output of the integrator formed by U1c through the voltage divider formed by R9 and R10. The loop reaches a stable operating point when the output of the comparator under test has a duty cycle of exactly 50%, which can only occur when the incoming triangle wave is sliced symmetrically or when the voltage at the noninverting input exactly equals the input offset voltage.

Voltage divider R9 and R10 provides a step up of the input offset voltage by a factor of 100 to make measurement easier. The values of R5, R8, R9, and R10 can significantly influence the accuracy of the reading; therefore, it is suggested that their tolerance level be 1% or lower.

Measuring the extremely low values of input current requires isolation from all other sources of leakage current and compensation for the leakage of the test socket and board. With a good picoammeter, the socket and board leakage can be measured with no device in the socket. Subsequently, this open-socket leakage value can be subtracted from the measurement obtained with a device in the socket to obtain the actual input current of the device.

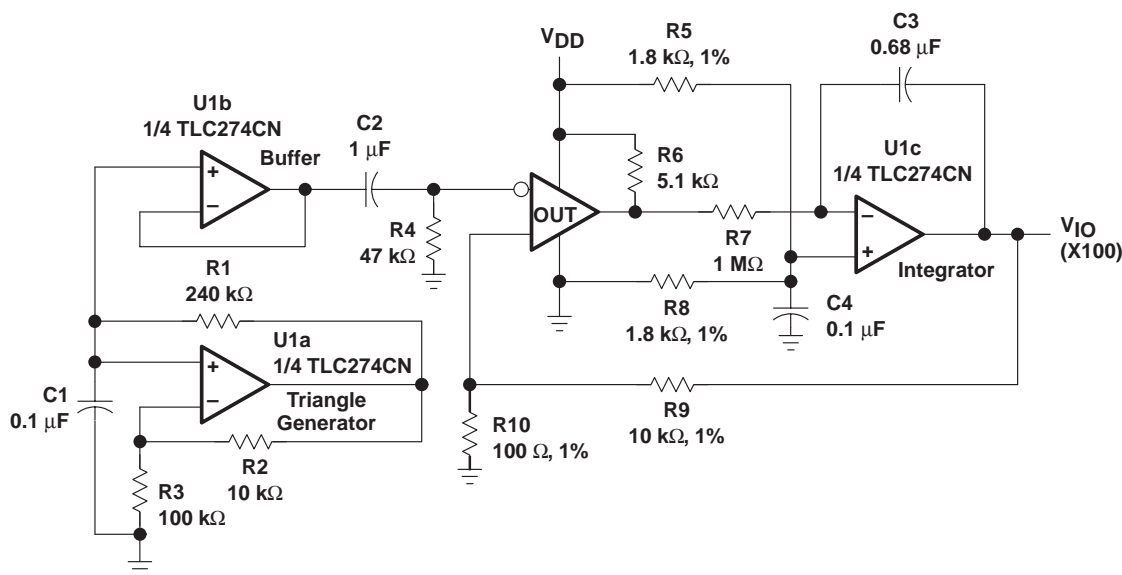
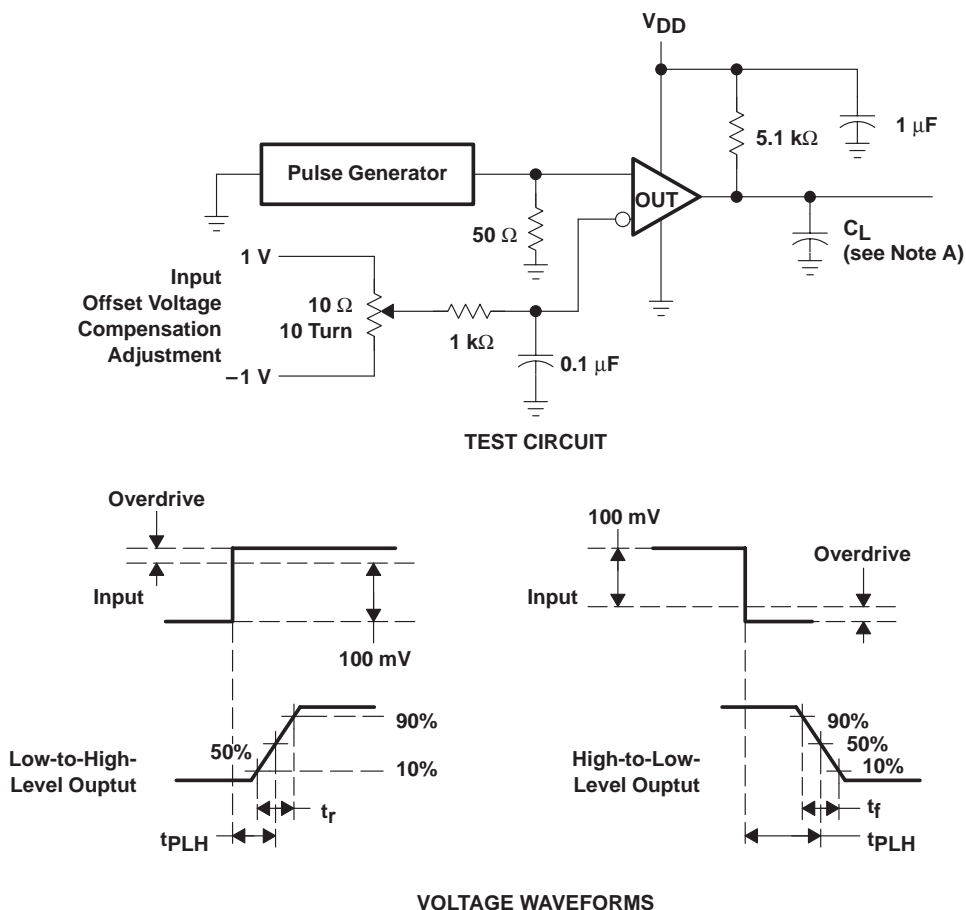

Figure 2. Test Circuit for Input Offset Voltage Measurement



### PARAMETER MEASUREMENT INFORMATION

Response time is defined as the interval between the application of an input step function and the instant when the output reaches 50% of its maximum value. Response time, low-to-high-level output, is measured from the trailing edge of the input pulse. Response-time measurement at low input signal levels can be greatly affected by the input offset voltage. The offset voltage should be balanced by the adjustment at the inverting input (as shown in Figure 3) so that the circuit is just at the transition point. Then a low signal, for example, 105-mV or 5-mV overdrive, causes the output to change.



NOTE A:  $C_L$  includes probe and jig capacitance.

**Figure 3. Response, Rise, and Fall Times Test Circuit and Voltage Waveforms**



## **IMPORTANT NOTICE**

Texas Instruments and its subsidiaries (TI) reserve the right to make changes to their products or to discontinue any product or service without notice, and advise customers to obtain the latest version of relevant information to verify, before placing orders, that information being relied on is current and complete. All products are sold subject to the terms and conditions of sale supplied at the time of order acknowledgement, including those pertaining to warranty, patent infringement, and limitation of liability.

TI warrants performance of its semiconductor products to the specifications applicable at the time of sale in accordance with TI's standard warranty. Testing and other quality control techniques are utilized to the extent TI deems necessary to support this warranty. Specific testing of all parameters of each device is not necessarily performed, except those mandated by government requirements.

**CERTAIN APPLICATIONS USING SEMICONDUCTOR PRODUCTS MAY INVOLVE POTENTIAL RISKS OF DEATH, PERSONAL INJURY, OR SEVERE PROPERTY OR ENVIRONMENTAL DAMAGE ("CRITICAL APPLICATIONS"). TI SEMICONDUCTOR PRODUCTS ARE NOT DESIGNED, AUTHORIZED, OR WARRANTED TO BE SUITABLE FOR USE IN LIFE-SUPPORT DEVICES OR SYSTEMS OR OTHER CRITICAL APPLICATIONS. INCLUSION OF TI PRODUCTS IN SUCH APPLICATIONS IS UNDERSTOOD TO BE FULLY AT THE CUSTOMER'S RISK.**

In order to minimize risks associated with the customer's applications, adequate design and operating safeguards must be provided by the customer to minimize inherent or procedural hazards.

TI assumes no liability for applications assistance or customer product design. TI does not warrant or represent that any license, either express or implied, is granted under any patent right, copyright, mask work right, or other intellectual property right of TI covering or relating to any combination, machine, or process in which such semiconductor products or services might be or are used. TI's publication of information regarding any third party's products or services does not constitute TI's approval, warranty or endorsement thereof.