

CDC111

1-LINE TO 9-LINE DIFFERENTIAL LVPECL CLOCK DRIVER

SCAS321G – SEPTEMBER 1993 – REVISED AUGUST 1999

- Low-Output Skew for Clock-Distribution Applications
- Differential Low-Voltage Pseudo-ECL (LVPECL)-Compatible Inputs and Outputs
- Distributes Differential Clock Inputs to Nine Differential Clock Outputs
- Output Reference Voltage, V_{REF} , Allows Distribution From a Single-Ended Clock Input
- Single-Ended LVPECL-Compatible Output Enable
- Packaged in Plastic Chip Carrier

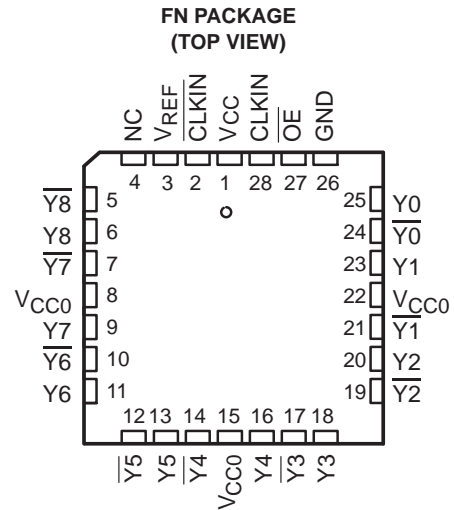

NC – No internal connection

description

The differential LVPECL clock-driver circuit distributes one pair of differential LVPECL clock inputs (\overline{CLKIN} , $CLKIN$) to nine pairs of differential clock (Y , \overline{Y}) outputs with minimum skew for clock distribution. It is specifically designed for driving 50- Ω transmission lines.

When the output-enable (\overline{OE}) is low, the nine differential outputs switch at the same frequency as the differential clock inputs. When \overline{OE} is high, the nine differential outputs are in static states (Y outputs are in the low state, \overline{Y} outputs are in the high state).

The V_{REF} output can be strapped to the \overline{CLKIN} input for a single-ended $CLKIN$ input.

The CDC111 is characterized for operation from 0°C to 70°C.

FUNCTION TABLE

INPUTS			OUTPUTS	
$CLKIN$	\overline{CLKIN}	\overline{OE}	Y_n	\overline{Y}_n
X	X	H	L	H
L	H	L	L	H
H	L	L	H	L
L	V_{REF}	L	L	H
H	V_{REF}	L	H	L
V_{REF}	L	L	H	L
V_{REF}	H	L	L	H



Please be aware that an important notice concerning availability, standard warranty, and use in critical applications of Texas Instruments semiconductor products and disclaimers thereto appears at the end of this data sheet.

PRODUCTION DATA information is current as of publication date. Products conform to specifications per the terms of Texas Instruments standard warranty. Production processing does not necessarily include testing of all parameters.

**TEXAS
INSTRUMENTS**

POST OFFICE BOX 655303 • DALLAS, TEXAS 75265

Copyright © 1999, Texas Instruments Incorporated

CDC111

1-LINE TO 9-LINE DIFFERENTIAL LVPECL CLOCK DRIVER

SCAS321G – SEPTEMBER 1993 – REVISED AUGUST 1999

logic diagram (positive logic)

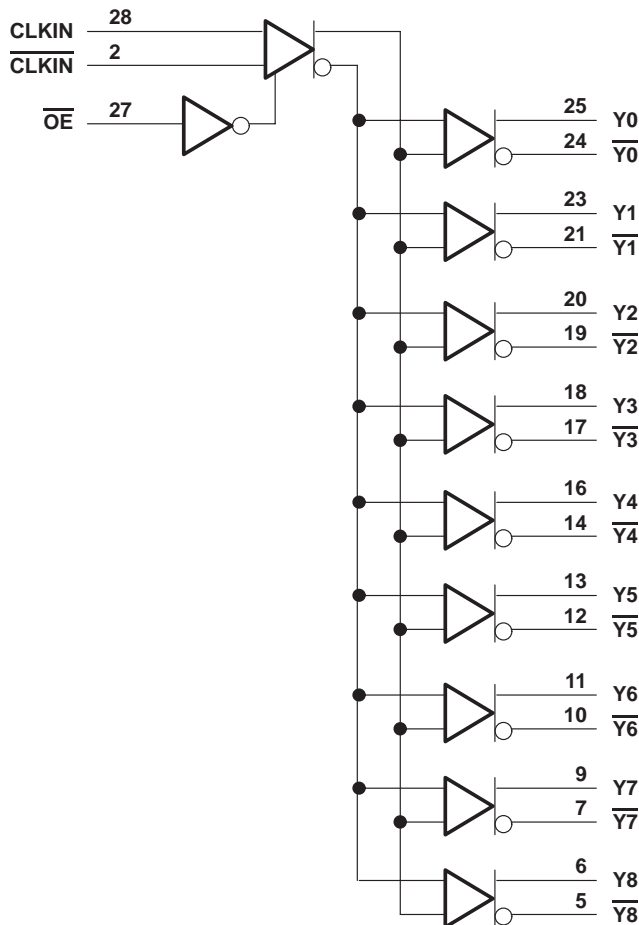

absolute maximum ratings over operating free-air temperature range (unless otherwise noted)†

Supply voltage range, V_{CC}	-0.5 V to 4.6 V
Input voltage range, V_I (see Note 1)	-0.5 V to $V_{CC} + 0.5$ V
Output voltage range, V_O (see Note 1)	-0.5 V to $V_{CC} + 0.5$ V
Input clamp current, I_{IK} ($V_I < 0$)	-18 mA
Output clamp current, I_{OK} ($V_O < 0$ or $V_O > V_{CC}$)	-18 mA
Continuous output current, I_O ($V_O = 0$ to V_{CC})	-50 mA
Continuous current through V_{CC} or GND	± 80 mA
Maximum power dissipation at $T_A = 55^\circ\text{C}$ (in still air) (see Note 2)	525 mW
Storage temperature range, T_{stg}	-65°C to 150°C

† Stresses beyond those listed under "absolute maximum ratings" may cause permanent damage to the device. These are stress ratings only, and functional operation of the device at these or any other conditions beyond those indicated under "recommended operating conditions" is not implied. Exposure to absolute-maximum-rated conditions for extended periods may affect device reliability.

- NOTES: 1. The input and output negative-voltage ratings may be exceeded if the input and output clamp-current ratings are observed.
 2. The maximum package power dissipation is calculated using a junction temperature of 150°C and a board trace length of 750 mils. For more information, refer to the *Package Thermal Considerations* application note in the *ABT Advanced BiCMOS Technology Data Book*, literature number SCBD002.



POST OFFICE BOX 655303 • DALLAS, TEXAS 75265

CDC111

1-LINE TO 9-LINE DIFFERENTIAL LVPECL CLOCK DRIVER

SCAS321G – SEPTEMBER 1993 – REVISED AUGUST 1999

recommended operating conditions (see Note 3)

		MIN	MAX	UNIT	
V _{CC}	Supply voltage	3	3.6	V	
V _{IH}	High-level input voltage	V _{CC} = 3 V to 3.6 V	V _{CC} -1.165	V _{CC} -0.88	V
		V _{CC} = 3.3 V	2.135	2.420	V
V _{IL}	Low-level input voltage	V _{CC} = 3 V to 3.6 V	V _{CC} -1.81	V _{CC} -1.475	V
		V _{CC} = 3.3 V	1.49	1.825	V
T _A	Operating free-air temperature	0	70	°C	
f _{clock}	Input frequency		500	MHz	

NOTE 3: V_{CC} = V_{CCO}

electrical characteristics over recommended operating free-air temperature range (unless otherwise noted)

PARAMETER	TEST CONDITIONS	MIN	MAX	UNIT
V _{REF}	V _{CC} = 3 V to 3.6 V	V _{CC} -1.38	V _{CC} -1.26	V
	V _{CC} = 3.3 V	1.92	2.04	
V _{OH}	V _{CC} = 3 V to 3.6 V	V _{CC} -1.025	V _{CC} -0.88	V
	V _{CC} = 3.3 V	2.275	2.42	
V _{OL}	V _{CC} = 3 V to 3.6 V	V _{CC} -1.81	V _{CC} -1.62	V
	V _{CC} = 3.3 V	1.49	1.68	
I _I	V _I = 2.4 V, V _{CC} = 3.6 V		150	μA
I _{CC}	I _O = 0, V _{CC} = 3.6 V		80	mA

switching characteristics over recommended operating free-air temperature range, V_{CC} = 3.3 V ± 0.3 V (see Figures 1 and 2)

PARAMETER	FROM (INPUT)	TO (OUTPUT)	MIN	MAX	UNIT
t _{PLH}	CLKIN, $\overline{\text{CLKIN}}$	Y, $\overline{\text{Y}}$	450	600	ps
t _{PHL}			450	600	
t _{PHL}	$\overline{\text{OE}}$	Y, $\overline{\text{Y}}$		900	ps
t _{sk(o)}		Y, $\overline{\text{Y}}$		50	ps
t _{sk(pr)}		Y, $\overline{\text{Y}}$		150	ps
t _r		Y, $\overline{\text{Y}}$	200	600	ps
t _f		Y, $\overline{\text{Y}}$	200	600	ps



CDC111

1-LINE TO 9-LINE DIFFERENTIAL LVPECL CLOCK DRIVER

SCAS321G – SEPTEMBER 1993 – REVISED AUGUST 1999

PARAMETER MEASUREMENT INFORMATION

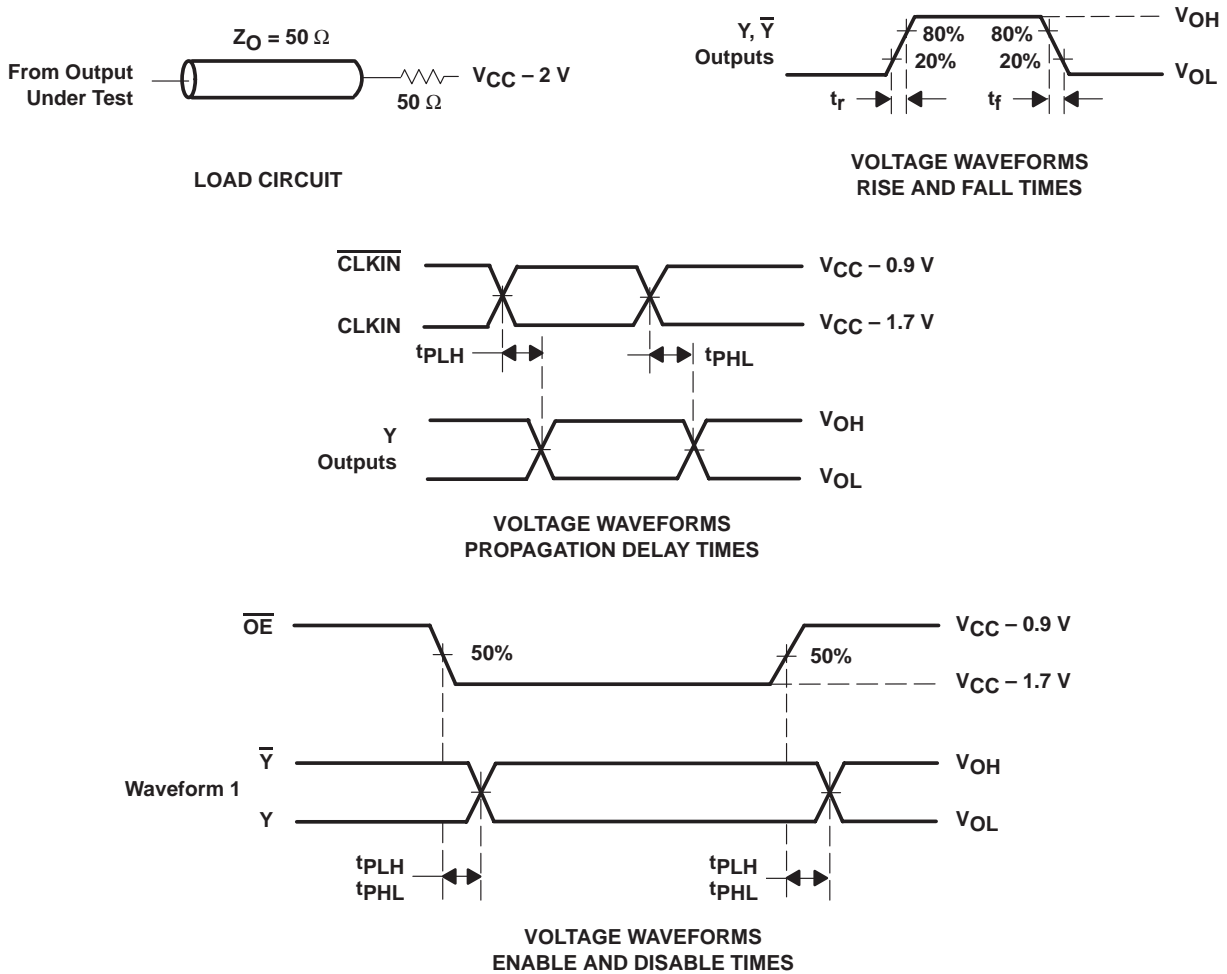

- NOTES: A. All input pulses are supplied by generators having the following characteristics: $PRR \leq 45 \text{ MHz}$, $Z_O = 50 \Omega$, $t_r \leq 1 \text{ ns}$, $t_f \leq 1 \text{ ns}$.
 B. Waveform 1 is for a \bar{Y} output with internal conditions such that the output is high except when disabled by the output control, and for a Y output with internal conditions such that the output is low except when disabled by the output control.
 C. The outputs are measured one at a time with one transition per measurement.

Figure 1. Load Circuit and Voltage Waveforms

PARAMETER MEASUREMENT INFORMATION

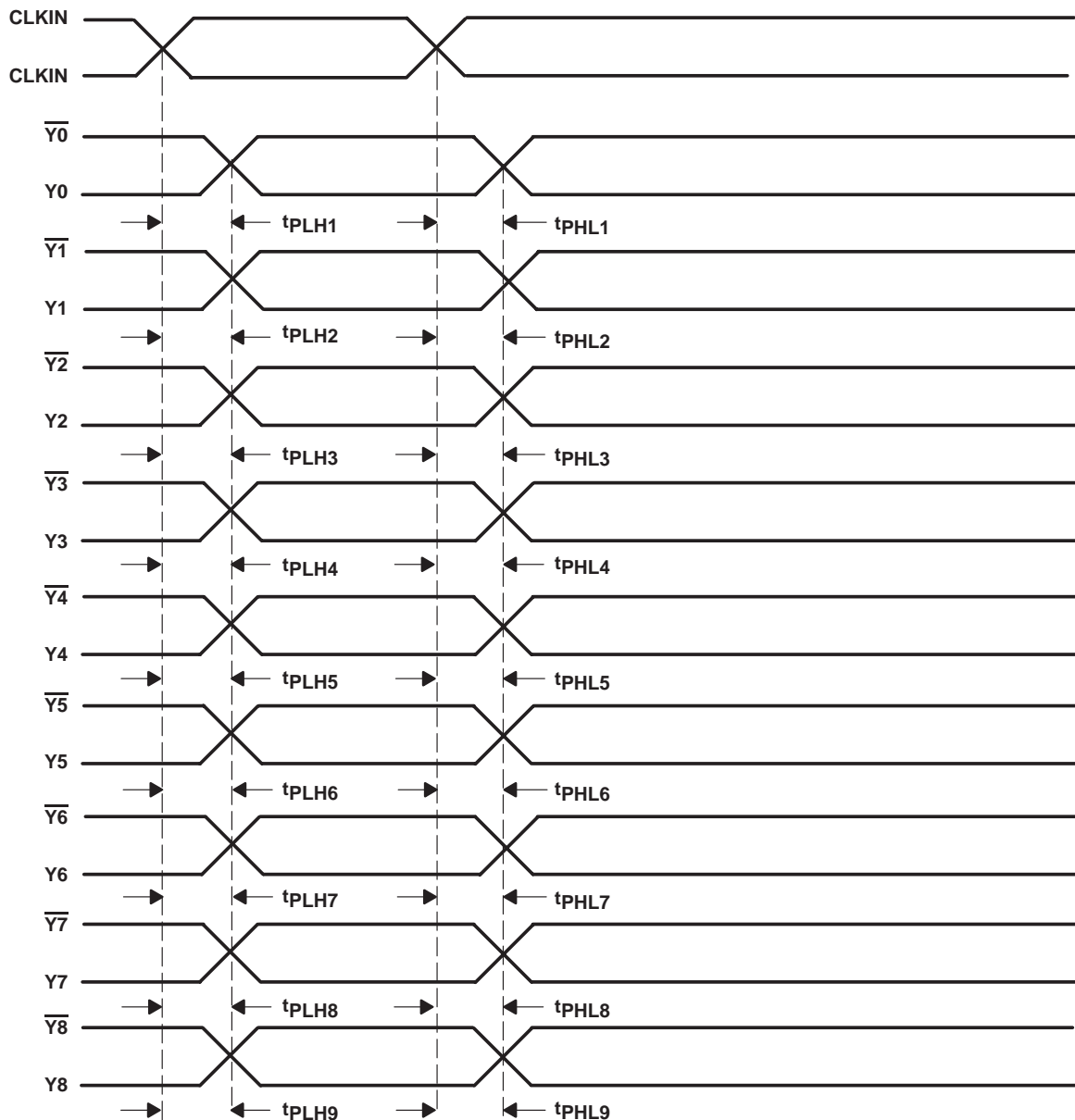

- NOTES: A. Output skew, $t_{sk(o)}$, is calculated as the greater of:
- The difference between the fastest and slowest t_{PLHn} ($n = 1, 2, \dots, 9$)
 - The difference between the fastest and slowest t_{PHLn} ($n = 1, 2, \dots, 9$)
- B. Process skew, $t_{sk(pr)}$, is calculated as the greater of:
- The difference between the fastest and slowest t_{PLHn} ($n = 1, 2, \dots, 9$)
 - The difference between the fastest and slowest t_{PHLn} ($n = 1, 2, \dots, 9$) across multiple devices

Figure 2. Waveforms for Calculation of $t_{sk(o)}$, $t_{sk(pr)}$

CDC111 1-LINE TO 9-LINE DIFFERENTIAL LVPECL CLOCK DRIVER

SCAS321G – SEPTEMBER 1993 – REVISED AUGUST 1999

MECHANICAL DATA

FN (S-PQCC-J**)

PLASTIC J-LEADED CHIP CARRIER

20 PIN SHOWN

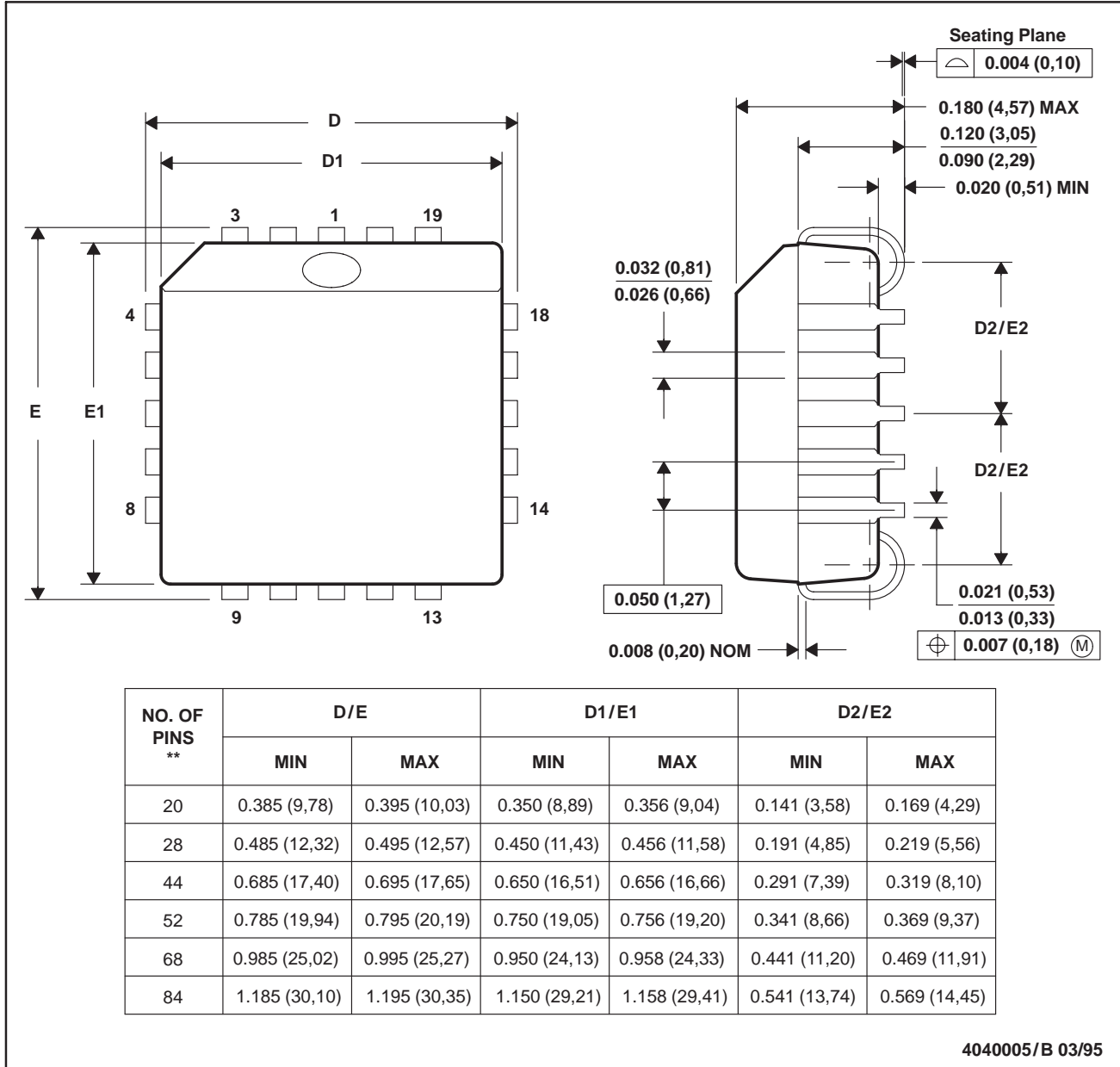

- NOTES: A. All linear dimensions are in inches (millimeters).
 B. This drawing is subject to change without notice.
 C. Falls within JEDEC MS-018

IMPORTANT NOTICE

Texas Instruments and its subsidiaries (TI) reserve the right to make changes to their products or to discontinue any product or service without notice, and advise customers to obtain the latest version of relevant information to verify, before placing orders, that information being relied on is current and complete. All products are sold subject to the terms and conditions of sale supplied at the time of order acknowledgement, including those pertaining to warranty, patent infringement, and limitation of liability.

TI warrants performance of its semiconductor products to the specifications applicable at the time of sale in accordance with TI's standard warranty. Testing and other quality control techniques are utilized to the extent TI deems necessary to support this warranty. Specific testing of all parameters of each device is not necessarily performed, except those mandated by government requirements.

CERTAIN APPLICATIONS USING SEMICONDUCTOR PRODUCTS MAY INVOLVE POTENTIAL RISKS OF DEATH, PERSONAL INJURY, OR SEVERE PROPERTY OR ENVIRONMENTAL DAMAGE ("CRITICAL APPLICATIONS"). TI SEMICONDUCTOR PRODUCTS ARE NOT DESIGNED, AUTHORIZED, OR WARRANTED TO BE SUITABLE FOR USE IN LIFE-SUPPORT DEVICES OR SYSTEMS OR OTHER CRITICAL APPLICATIONS. INCLUSION OF TI PRODUCTS IN SUCH APPLICATIONS IS UNDERSTOOD TO BE FULLY AT THE CUSTOMER'S RISK.

In order to minimize risks associated with the customer's applications, adequate design and operating safeguards must be provided by the customer to minimize inherent or procedural hazards.

TI assumes no liability for applications assistance or customer product design. TI does not warrant or represent that any license, either express or implied, is granted under any patent right, copyright, mask work right, or other intellectual property right of TI covering or relating to any combination, machine, or process in which such semiconductor products or services might be or are used. TI's publication of information regarding any third party's products or services does not constitute TI's approval, warranty or endorsement thereof.