

# CDC2509B

## 3.3-V PHASE-LOCK LOOP CLOCK DRIVER

SCAS613 – SEPTEMBER 1998

- **Designed to Meet PC SDRAM Registered DIMM Specification**
- **Spread Spectrum Clock Compatible**
- **Operating Frequency 25 MHz to 125 MHz**
- **tPhase Error Minus Jitter at 66MHz to 100 MHz is  $\pm 150$  ps**
- **Jitter (pk – pk) at 66 MHz to 100 MHz is  $\pm 80$  ps**
- **Jitter (cyc – cyc) at 66 MHz to 100 MHz is |100 ps|**
- **Available in Plastic 24-Pin TSSOP**
- **Phase-Lock Loop Clock Distribution for Synchronous DRAM Applications**
- **Distributes One Clock Input to One Bank of Five and One Bank of Four Outputs**
- **Separate Output Enable for Each Output Bank**
- **External Feedback (FBIN) Terminal Is Used to Synchronize the Outputs to the Clock Input**
- **On-Chip Series Damping Resistors**
- **No External RC Network Required**
- **Operates at 3.3-V**

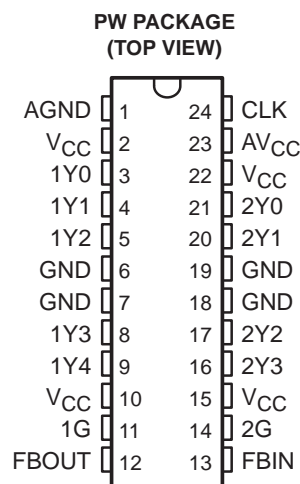

### description

The CDC2509B is a high-performance, low-skew, low-jitter, phase-lock loop (PLL) clock driver. It uses a PLL to precisely align, in both frequency and phase, the feedback (FBOUT) output to the clock (CLK) input signal. It is specifically designed for use with synchronous DRAMs. The CDC2509B operates at 3.3-V V<sub>CC</sub>. It also provides integrated series-damping resistors that make it ideal for driving point-to-point loads.

One bank of five outputs and one bank of four outputs provide nine low-skew, low-jitter copies of CLK. Output signal duty cycles are adjusted to 50%, independent of the duty cycle at CLK. Each bank of outputs is enabled or disabled separately via the control (1G and 2G) inputs. When the G inputs are high, the outputs switch in phase and frequency with CLK; when the G inputs are low, the outputs are disabled to the logic-low state.

Unlike many products containing PLLs, the CDC2509B does not require external RC networks. The loop filter for the PLL is included on-chip, minimizing component count, board space, and cost.

Because it is based on PLL circuitry, the CDC2509B requires a stabilization time to achieve phase lock of the feedback signal to the reference signal. This stabilization time is required, following power up and application of a fixed-frequency, fixed-phase signal at CLK, and following any changes to the PLL reference or feedback signals. The PLL can be bypassed for test purposes by strapping AV<sub>CC</sub> to ground.

The CDC2509B is characterized for operation from 0°C to 70°C.

For application information refer to application reports *High Speed Distribution Design Techniques for CDC509/516/2509/2510/2516* (literature number SLMA003) and *Using CDC2509A/2510A PLL with Spread Spectrum Clocking (SSC)* (literature number SCAA039).



Please be aware that an important notice concerning availability, standard warranty, and use in critical applications of Texas Instruments semiconductor products and disclaimers thereto appears at the end of this data sheet.

PRODUCTION DATA information is current as of publication date. Products conform to specifications per the terms of Texas Instruments standard warranty. Production processing does not necessarily include testing of all parameters.

**TEXAS  
INSTRUMENTS**

POST OFFICE BOX 655303 • DALLAS, TEXAS 75265

Copyright © 1998, Texas Instruments Incorporated

# CDC2509B

## 3.3-V PHASE-LOCK LOOP CLOCK DRIVER

SCAS613 – SEPTEMBER 1998

FUNCTION TABLE

INPUTS			OUTPUTS		
1G	2G	CLK	1Y (0:4)	2Y (0:3)	FBOUR
X	X	L	L	L	L
L	L	H	L	L	H
L	H	H	L	H	H
H	L	H	H	L	H
H	H	H	H	H	H

### functional block diagram

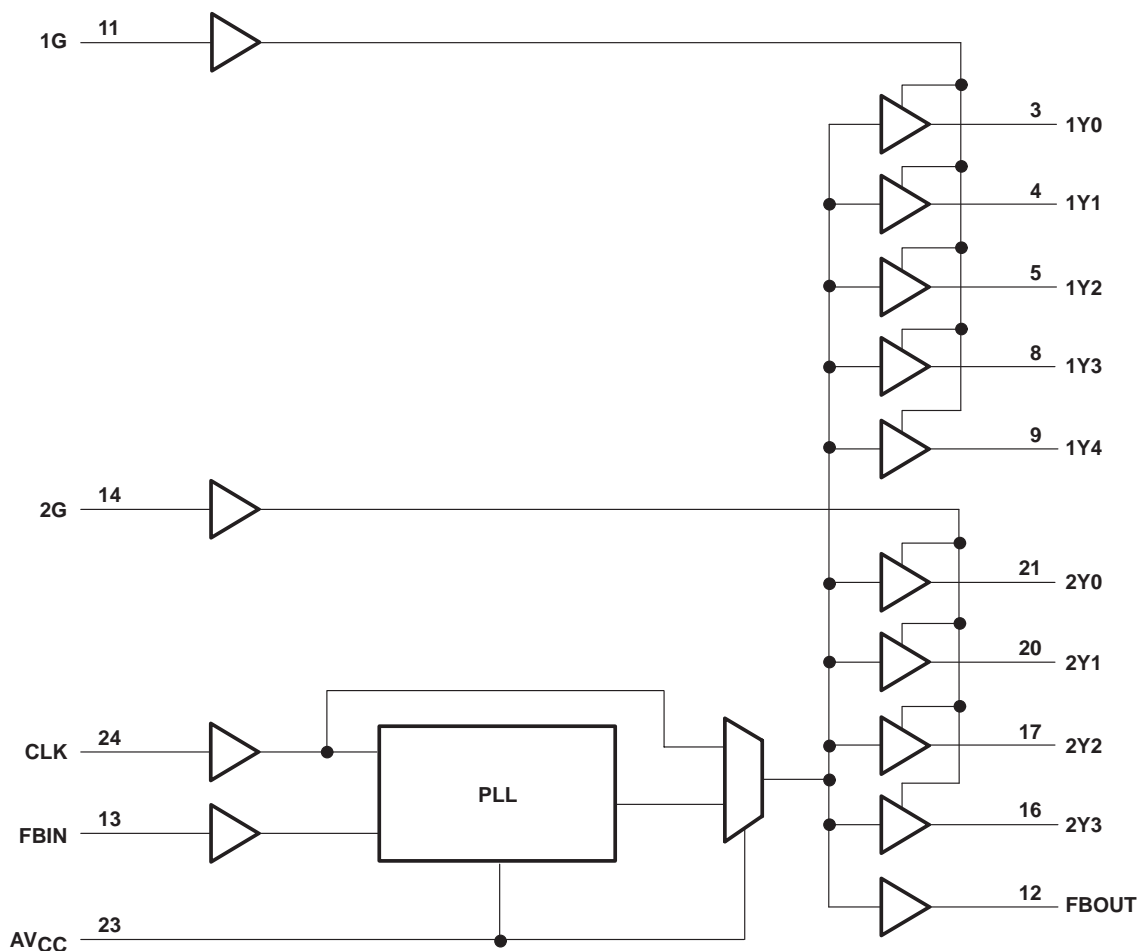

AVAILABLE OPTIONS

T <sub>A</sub>	PACKAGE
	SMALL OUTLINE (PW)
0°C to 70°C	CDC2509BPWR



POST OFFICE BOX 655303 • DALLAS, TEXAS 75265

# CDC2509B

## 3.3-V PHASE-LOCK LOOP CLOCK DRIVER

SCAS613 – SEPTEMBER 1998

### Terminal Functions

TERMINAL		TYPE	DESCRIPTION
NAME	NO.		
CLK	24	I	Clock input. CLK provides the clock signal to be distributed by the CDC2509B clock driver. CLK is used to provide the reference signal to the integrated PLL that generates the clock output signals. CLK must have a fixed frequency and fixed phase for the PLL to obtain phase lock. Once the circuit is powered up and a valid CLK signal is applied, a stabilization time is required for the PLL to phase lock the feedback signal to its reference signal.
FBIN	13	I	Feedback input. FBIN provides the feedback signal to the internal PLL. FBIN must be hard-wired to FBOUT to complete the PLL. The integrated PLL synchronizes CLK and FBIN so that there is nominally zero phase error between CLK and FBIN.
1G	11	I	Output bank enable. 1G is the output enable for outputs 1Y(0:4). When 1G is low, outputs 1Y(0:4) are disabled to a logic-low state. When 1G is high, all outputs 1Y(0:4) are enabled and switch at the same frequency as CLK.
2G	14	I	Output bank enable. 2G is the output enable for outputs 2Y(0:3). When 2G is low, outputs 2Y(0:3) are disabled to a logic-low state. When 2G is high, all outputs 2Y(0:3) are enabled and switch at the same frequency as CLK.
FBOUT	12	O	Feedback output. FBOUT is dedicated for external feedback. It switches at the same frequency as CLK. When externally wired to FBIN, FBOUT completes the feedback loop of the PLL. FBOUT has an integrated 25- $\Omega$ series-damping resistor.
1Y (0:4)	3, 4, 5, 8, 9	O	Clock outputs. These outputs provide low-skew copies of CLK. Output bank 1Y(0:4) is enabled via the 1G input. These outputs can be disabled to a logic-low state by deasserting the 1G control input. Each output has an integrated 25- $\Omega$ series-damping resistor.
2Y (0:3)	16, 17, 20, 21	O	Clock outputs. These outputs provide low-skew copies of CLK. Output bank 2Y(0:3) is enabled via the 2G input. These outputs can be disabled to a logic-low state by deasserting the 2G control input. Each output has an integrated 25- $\Omega$ series-damping resistor.
AV <sub>CC</sub>	23	Power	Analog power supply. AV <sub>CC</sub> provides the power reference for the analog circuitry. In addition, AV <sub>CC</sub> can be used to bypass the PLL for test purposes. When AV <sub>CC</sub> is strapped to ground, PLL is bypassed and CLK is buffered directly to the device outputs.
AGND	1	Ground	Analog ground. AGND provides the ground reference for the analog circuitry.
V <sub>CC</sub>	2, 10, 15, 22	Power	Power supply
GND	6, 7, 18, 19	Ground	Ground



# CDC2509B

## 3.3-V PHASE-LOCK LOOP CLOCK DRIVER

SCAS613 – SEPTEMBER 1998

### absolute maximum ratings over operating free-air temperature range (unless otherwise noted)†

Supply voltage range, $AV_{CC}$ (see Note 1)	$AV_{CC} < V_{CC} + 0.7$ V
Supply voltage range, $V_{CC}$	-0.5 V to 4.6 V
Input voltage range, $V_I$ (see Note 2)	-0.5 V to 6.5 V
Voltage range applied to any output in the high or low state, $V_O$ (see Notes 2 and 3)	-0.5 V to $V_{CC} + 0.5$ V
Input clamp current, $I_{IK}$ ( $V_I < 0$ )	-50 mA
Output clamp current, $I_{OK}$ ( $V_O < 0$ or $V_O > V_{CC}$ )	±50 mA
Continuous output current, $I_O$ ( $V_O = 0$ to $V_{CC}$ )	±50 mA
Continuous current through each $V_{CC}$ or GND	±100 mA
Maximum power dissipation at $T_A = 55^\circ\text{C}$ (in still air) (see Note 4)	0.7 W
Storage temperature range, $T_{stg}$	-65°C to 150°C

† Stresses beyond those listed under “absolute maximum ratings” may cause permanent damage to the device. These are stress ratings only, and functional operation of the device at these or any other conditions beyond those indicated under “recommended operating conditions” is not implied. Exposure to absolute-maximum-rated conditions for extended periods may affect device reliability.

- NOTES:
1.  $AV_{CC}$  **must not** exceed  $V_{CC}$ .
  2. The input and output negative-voltage ratings may be exceeded if the input and output clamp-current ratings are observed.
  3. This value is limited to 4.6 V maximum.
  4. The maximum package power dissipation is calculated using a junction temperature of 150°C and a board trace length of 750 mils. For more information, refer to the *Package Thermal Considerations* application note in the *ABT Advanced BiCMOS Technology Data Book*, literature number SCBD002.

### recommended operating conditions (see Note 5)

	MIN	MAX	UNIT
$V_{CC}, AV_{CC}$ Supply voltage	3	3.6	V
$V_{IH}$ High-level input voltage	2		V
$V_{IL}$ Low-level input voltage		0.8	V
$V_I$ Input voltage	0	$V_{CC}$	V
$I_{OH}$ High-level output current		-12	mA
$I_{OL}$ Low-level output current		12	mA
$T_A$ Operating free-air temperature	0	70	°C

NOTE 5: Unused inputs must be held high or low to prevent them from floating.



# CDC2509B

## 3.3-V PHASE-LOCK LOOP CLOCK DRIVER

SCAS613 – SEPTEMBER 1998

### electrical characteristics over recommended operating free-air temperature range (unless otherwise noted)

PARAMETER	TEST CONDITIONS	V <sub>CC</sub> , AV <sub>CC</sub>	MIN	TYP <sup>‡</sup>	MAX	UNIT
V <sub>IK</sub>	I <sub>I</sub> = -18 mA	3 V			-1.2	V
V <sub>OH</sub>	I <sub>OH</sub> = -100 μA	MIN to MAX	V <sub>CC</sub> -0.2			V
	I <sub>OH</sub> = -12 mA	3 V	2.1			
	I <sub>OH</sub> = -6 mA	3 V	2.4			
V <sub>OL</sub>	I <sub>OL</sub> = 100 μA	MIN to MAX	0.2			V
	I <sub>OL</sub> = 12 mA	3 V	0.8			
	I <sub>OL</sub> = 6 mA	3 V	0.55			
I <sub>I</sub>	V <sub>I</sub> = V <sub>CC</sub> or GND	3.6 V			±5	μA
I <sub>CC</sub> <sup>§</sup>	V <sub>I</sub> = V <sub>CC</sub> or GND, I <sub>O</sub> = 0, Outputs: low or high	3.6 V			10	μA
ΔI <sub>CC</sub>	One input at V <sub>CC</sub> - 0.6 V, Other inputs at V <sub>CC</sub> or GND	3.3 V to 3.6 V			500	μA
C <sub>i</sub>	V <sub>I</sub> = V <sub>CC</sub> or GND	3.3 V		4		pF
C <sub>o</sub>	V <sub>O</sub> = V <sub>CC</sub> or GND	3.3 V		6		pF

<sup>‡</sup> For conditions shown as MIN or MAX, use the appropriate value specified under recommended operating conditions.

<sup>§</sup> For I<sub>CC</sub> of AV<sub>CC</sub>, and I<sub>CC</sub> vs Frequency (see Figures 7 and 8).

### timing requirements over recommended ranges of supply voltage and operating free-air temperature

	MIN	MAX	UNIT
f <sub>clk</sub> Clock frequency	25	125	MHz
Input clock duty cycle	40%	60%	
Stabilization time <sup>†</sup>		1	ms

<sup>†</sup> Time required for the integrated PLL circuit to obtain phase lock of its feedback signal to its reference signal. For phase lock to be obtained, a fixed-frequency, fixed-phase reference signal must be present at CLK. Until phase lock is obtained, the specifications for propagation delay, skew, and jitter parameters given in the switching characteristics table are not applicable. This parameter does not apply for input modulation under SSC application.

### switching characteristics over recommended ranges of supply voltage and operating free-air temperature, C<sub>L</sub> = 30 pF (see Note 6 and Figures 1 and 2)<sup>‡</sup>

PARAMETER	FROM (INPUT)/CONDITION	TO (OUTPUT)	V <sub>CC</sub> , AV <sub>CC</sub> = 3.3 V ± 0.165 V			V <sub>CC</sub> , AV <sub>CC</sub> = 3.3 V ± 0.3 V			UNIT
			MIN	TYP	MAX	MIN	TYP	MAX	
t <sub>phase error - jitter</sub> (see Notes 7 and 8, Figures 3, 4, and 5)	CLKIN <sup>↑</sup> = 66 MHz to 100 MHz	FBIN <sup>↑</sup>	-150		150	-200		200	ps
t <sub>sk(o)</sub> <sup>§</sup>	Any Y or FBOUT	Any Y or FBOUT						200	ps
Jitter <sub>(pk-pk)</sub> (see Figure 6)	Clkin = 66 MHz to 100 MHz	Any Y or FBOUT				-80		80	ps
Jitter <sub>(cycle-cycle)</sub> (see Figure 6)		Any Y or FBOUT						100	
Duty cycle	F(clkin > 60 MHz)	Any Y or FBOUT				45%		55%	
t <sub>r</sub>		Any Y or FBOUT		1.3	1.9	0.8		2.1	ns
t <sub>f</sub>		Any Y or FBOUT		1.7	2.5	1.2		2.7	ns

<sup>‡</sup> These parameters are not production tested.

<sup>§</sup> The t<sub>sk(o)</sub> specification is only valid for equal loading of all outputs.

NOTES: 6. The specifications for parameters in this table are applicable only after any appropriate stabilization time has elapsed.

7. This is considered as static phase error.

8. Phase error does not include jitter. The total phase error is -230 ps to 230 ps for the 5% V<sub>CC</sub> range.



CDC2509B  
3.3-V PHASE-LOCK LOOP CLOCK DRIVER

SCAS613 – SEPTEMBER 1998

PARAMETER MEASUREMENT INFORMATION

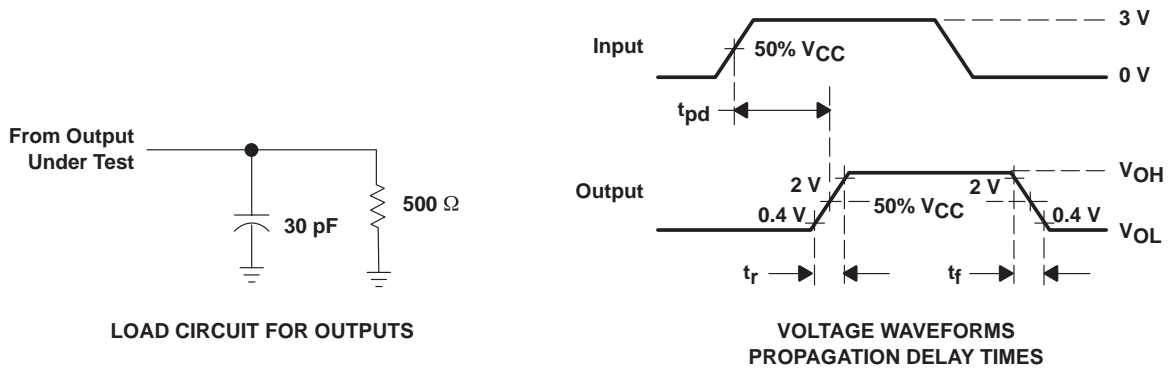

- NOTES: A. C<sub>L</sub> includes probe and jig capacitance.  
B. All input pulses are supplied by generators having the following characteristics: PRR ≤ 100 MHz, Z<sub>O</sub> = 50 Ω, t<sub>r</sub> ≤ 1.2 ns, t<sub>f</sub> ≤ 1.2 ns.  
C. The outputs are measured one at a time with one transition per measurement.

Figure 1. Load Circuit and Voltage Waveforms

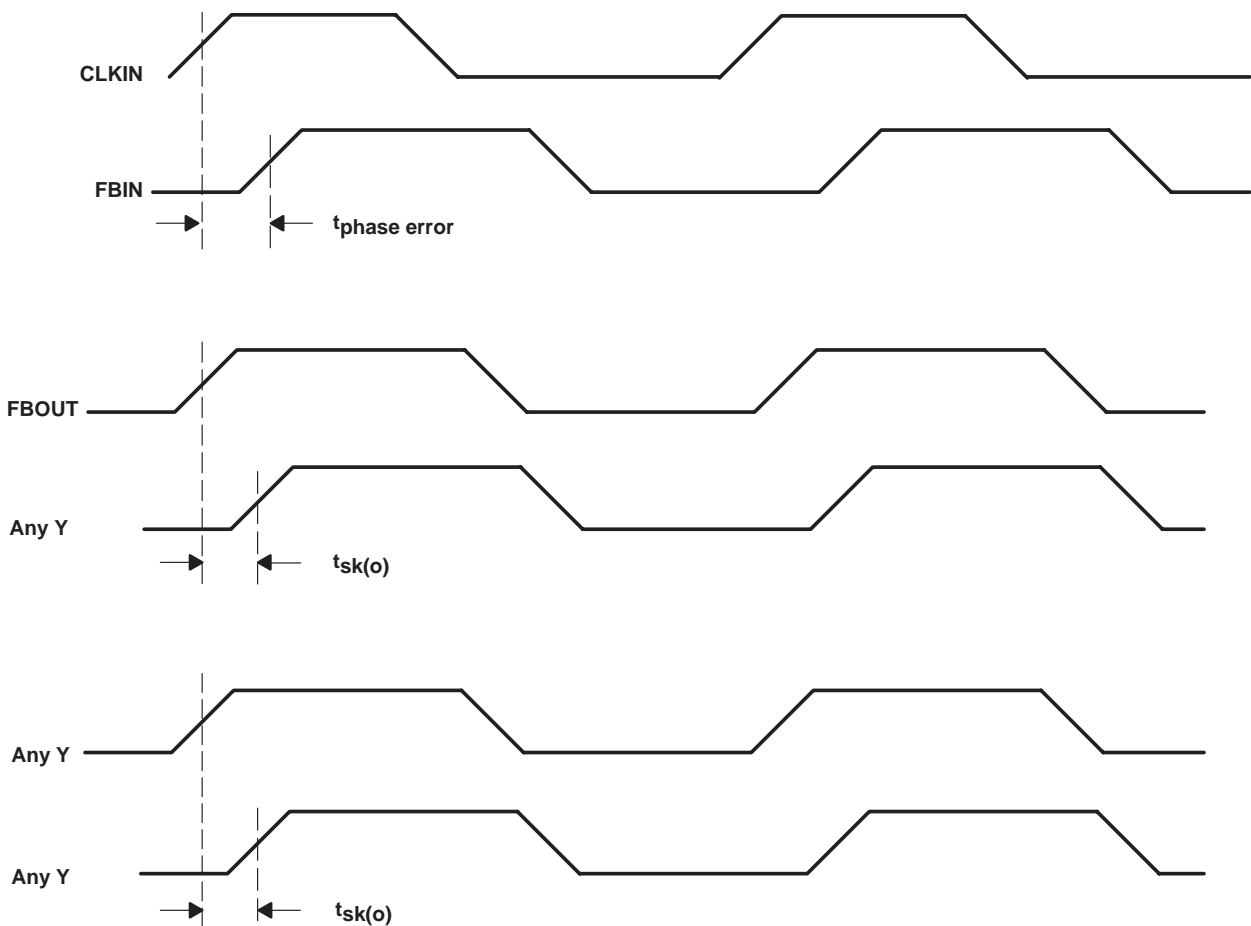

Figure 2. Phase Error and Skew Calculations

TYPICAL CHARACTERISTICS

PHASE ADJUSTMENT SLOPE AND PHASE ERROR  
vs  
LOAD CAPACITANCE

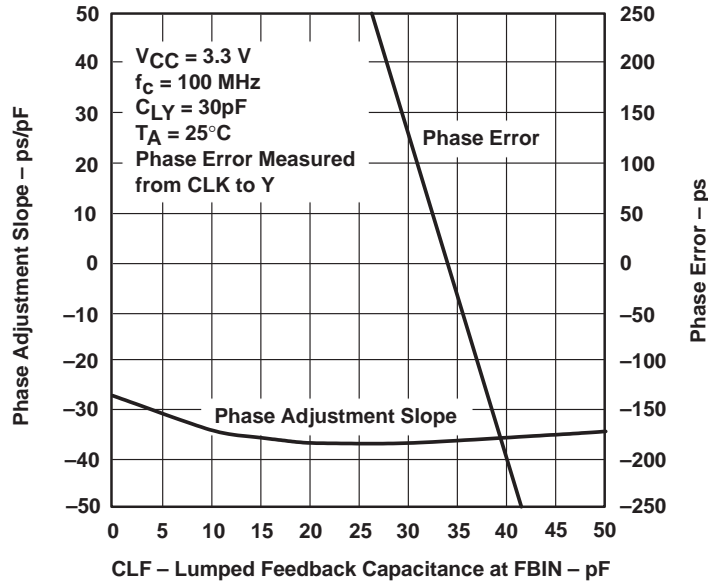

Figure 3

PHASE ERROR  
vs  
CLOCK FREQUENCY

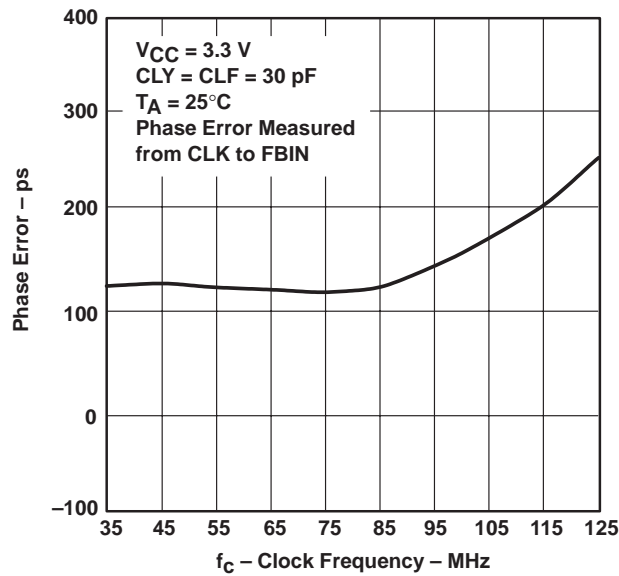

Figure 4

NOTES: A. CLY = Lumped capacitive load at Y  
B. CLF = Lumped feedback capacitance at FBIN

# CDC2509B

## 3.3-V PHASE-LOCK LOOP CLOCK DRIVER

SCAS613 – SEPTEMBER 1998

### TYPICAL CHARACTERISTICS

PHASE ERROR  
vs  
SUPPLY VOLTAGE

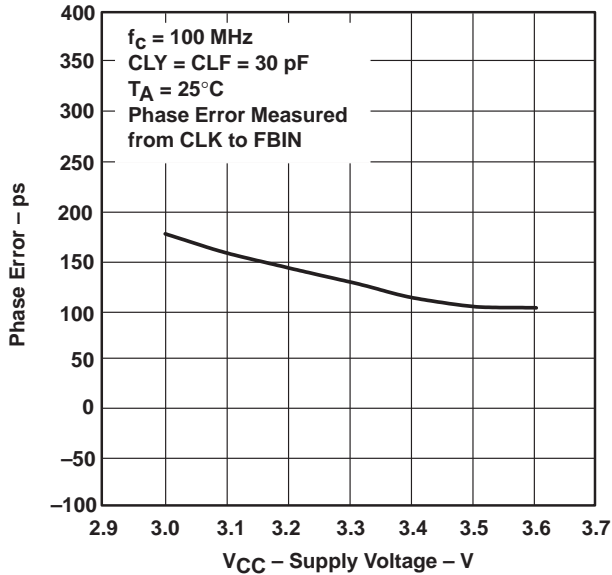

Figure 5

JITTER  
vs  
CLOCK FREQUENCY

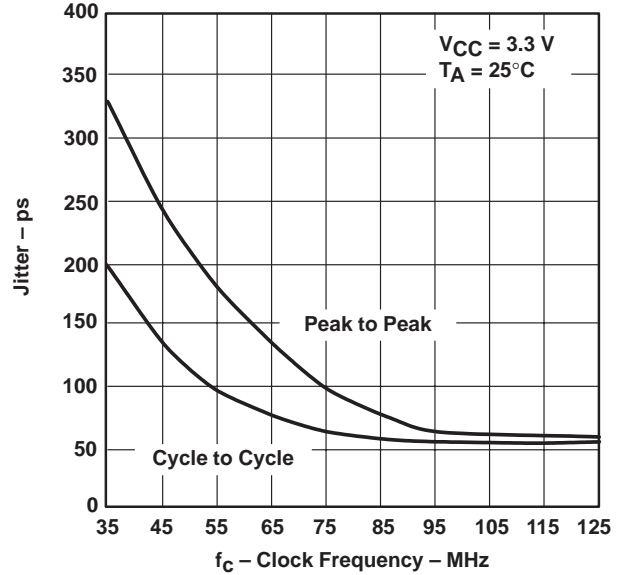

Figure 6

ANALOG SUPPLY CURRENT  
vs  
CLOCK FREQUENCY

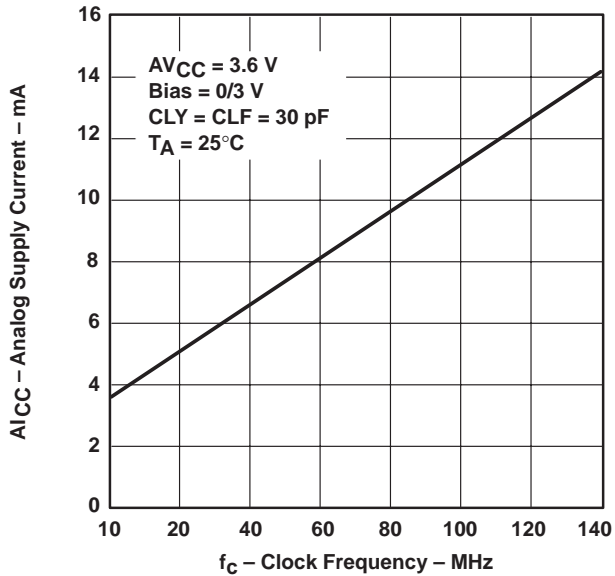

Figure 7

SUPPLY CURRENT  
vs  
CLOCK FREQUENCY

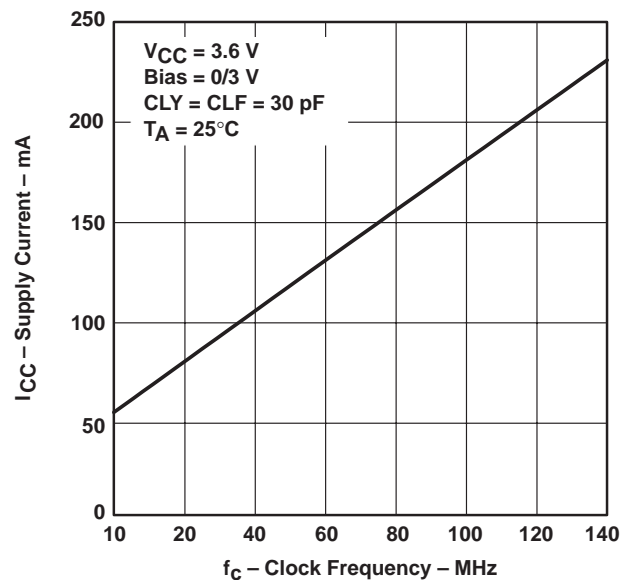

Figure 8

NOTES: A. CLY = Lumped capacitive load at Y  
 B. CLF = Lumped feedback capacitance at FBIN



**CDC2509B**  
**3.3-V PHASE-LOCK LOOP CLOCK DRIVER**

SCAS613 – SEPTEMBER 1998

**MECHANICAL INFORMATION**

**PW (R-PDSO-G\*\*)**

**PLASTIC SMALL-OUTLINE PACKAGE**

14 PIN SHOWN

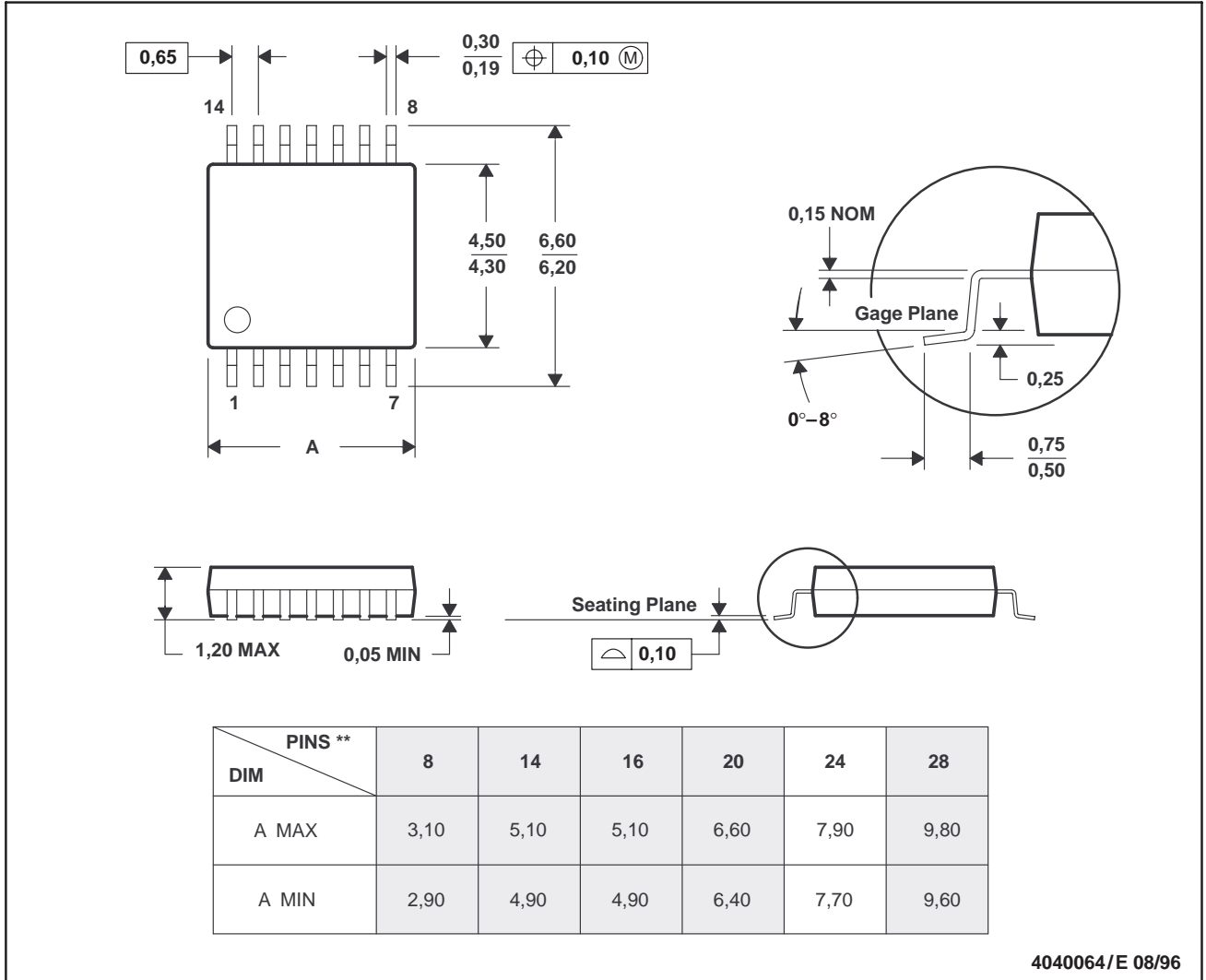

- NOTES: A. All linear dimensions are in millimeters.  
 B. This drawing is subject to change without notice.  
 C. Body dimensions do not include mold flash or protrusion not to exceed 0,15.  
 D. Falls within JEDEC MO-153

## **IMPORTANT NOTICE**

Texas Instruments and its subsidiaries (TI) reserve the right to make changes to their products or to discontinue any product or service without notice, and advise customers to obtain the latest version of relevant information to verify, before placing orders, that information being relied on is current and complete. All products are sold subject to the terms and conditions of sale supplied at the time of order acknowledgement, including those pertaining to warranty, patent infringement, and limitation of liability.

TI warrants performance of its semiconductor products to the specifications applicable at the time of sale in accordance with TI's standard warranty. Testing and other quality control techniques are utilized to the extent TI deems necessary to support this warranty. Specific testing of all parameters of each device is not necessarily performed, except those mandated by government requirements.

**CERTAIN APPLICATIONS USING SEMICONDUCTOR PRODUCTS MAY INVOLVE POTENTIAL RISKS OF DEATH, PERSONAL INJURY, OR SEVERE PROPERTY OR ENVIRONMENTAL DAMAGE ("CRITICAL APPLICATIONS"). TI SEMICONDUCTOR PRODUCTS ARE NOT DESIGNED, AUTHORIZED, OR WARRANTED TO BE SUITABLE FOR USE IN LIFE-SUPPORT DEVICES OR SYSTEMS OR OTHER CRITICAL APPLICATIONS. INCLUSION OF TI PRODUCTS IN SUCH APPLICATIONS IS UNDERSTOOD TO BE FULLY AT THE CUSTOMER'S RISK.**

In order to minimize risks associated with the customer's applications, adequate design and operating safeguards must be provided by the customer to minimize inherent or procedural hazards.

TI assumes no liability for applications assistance or customer product design. TI does not warrant or represent that any license, either express or implied, is granted under any patent right, copyright, mask work right, or other intellectual property right of TI covering or relating to any combination, machine, or process in which such semiconductor products or services might be or are used. TI's publication of information regarding any third party's products or services does not constitute TI's approval, warranty or endorsement thereof.