

TLC04/MF4A-50, TLC14/MF4A-100
BUTTERWORTH FOURTH-ORDER LOW-PASS
SWITCHED-CAPACITOR FILTERS

D2970, NOVEMBER 1986—REVISED NOVEMBER 1988

- Low Clock-to-Cutoff-Frequency Ratio Error
 TLC04/MF4A-50 ... $\pm 0.8\%$
 TLC14/MF4A-100 ... $\pm 1\%$
- Filter Cutoff Frequency Dependent Only on External-Clock Frequency Stability
- Minimum Filter Response Deviation Due to External Component Variations Over Time and Temperature
- Cutoff Frequency Range from 0.1 Hz to 30 kHz, $V_{CC} \pm = \pm 2.5 V$
- 5-V to 12-V Operation
- Self Clocking or TTL-Compatible and CMOS-Compatible Clock Inputs
- Low Supply Voltage Sensitivity
- Designed to be Interchangeable with National MF4-50 and MF4-100

D OR P PACKAGE
 (TOP VIEW)

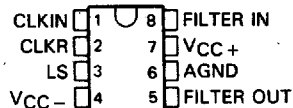

T-64-05

description

The TLC04/MF4A-50 and TLC14/MF4A-100 are monolithic Butterworth low-pass switched-capacitor filters. Each is designed as a low-cost, easy-to-use device providing accurate fourth-order low-pass filter functions in circuit design configurations.

Each filter features cutoff frequency stability that is dependent only on the external-clock frequency stability. The cutoff frequency is clock tunable and has a clock-to-cutoff frequency ratio of 50:1 with less than $\pm 0.8\%$ error for the TLC04/MF4A-50 and a clock-to-cutoff frequency ratio of 100:1 with less than $\pm 1\%$ error for the TLC14/MF4A-100. The input clock features self-clocking or TTL- or CMOS-compatible options in conjunction with the level shift (LS) pin.

The TLC04M/MF4A-50M and TLC14M/MF4A-100M are characterized over the full military temperature range of $-55^{\circ}C$ to $125^{\circ}C$. The TLC04I/MF4A-50I and TLC14I/MF4A-100I are characterized for operation from $-40^{\circ}C$ to $85^{\circ}C$. The TLC04C/MF4A-50C and TLC14C/MF4A-100C are characterized for operation from $0^{\circ}C$ to $70^{\circ}C$.

functional block diagram

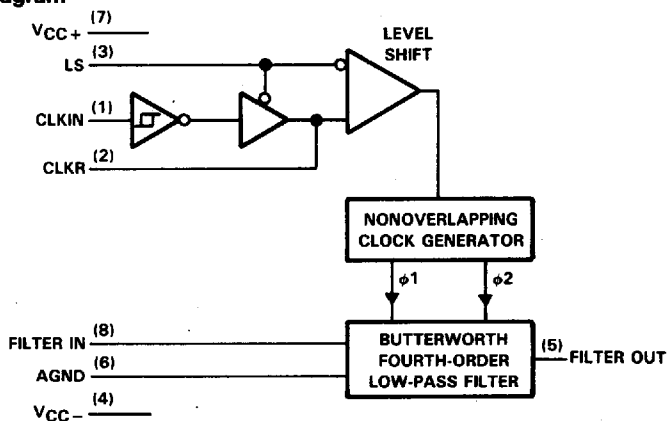

PRODUCTION DATA documents contain information current as of publication date. Products conform to specifications per the terms of Texas Instruments standard warranty. Production processing does not necessarily include testing of all parameters.



POST OFFICE BOX 655303 • DALLAS, TEXAS 75265

Copyright © 1986, Texas Instruments Incorporated

TLC04/MF4A-50, TLC14/MF4A-100
BUTTERWORTH FOURTH-ORDER LOW-PASS
SWITCHED-CAPACITOR FILTERS

T-64-05

AVAILABLE OPTIONS

T _A	CLOCK-TO-CUTOFF FREQUENCY RATIO	PACKAGE	
		SMALL OUTLINE (D)	PLASTIC DIP (P)
0°C to 70°C	50:1 100:1	TLC04CD/MF4A-50CD TLC14CD/MF4A-100CD	TLC04CP/MF4A-50CP TLC14CP/MF4A-100CP
-40°C to 85°C	50:1 100:1	TLC04ID/MF4A-50ID TLC14ID/MF4A-100ID	TLC04IP/MF4A-50IP TLC14IP/MF4A-100IP
-55°C to 125°C	50:1 100:1		TLC04MP/MF4A-50MP TLC14MP/MF4A-100MP

The D package is available taped and reeled. Add the suffix R to the device type (e.g., TLC04CDR/MF4A-50CDR).

pin description

PIN NAME	NO.	I/O	DESCRIPTION
AGND	6	I	Analog Ground — The noninverting input to the operational amplifiers of the Butterworth fourth-order low-pass filter.
CLKIN	1	I	Clock In — The clock input terminal for CMOS-compatible clock or self-clocking options. For either option, the Level Shift (LS) terminal is at V _{CC-} . For self-clocking, a resistor is connected between the CLKIN and CLKR terminal pins and a capacitor is connected from the CLKIN terminal pin to ground.
CLKR	2	I	Clock R — The clock input for a TTL-compatible clock. For a TTL clock, the level shift pin is connected to mid-supply and the CLKIN pin may be left open, but it is recommended that it be connected to either V _{CC+} or V _{CC-} .
FILTER IN	8	I	Filter Input
FILTER OUT	5	O	Butterworth fourth-order low-pass Filter Output
LS	3	I	Level Shift — This terminal accommodates the various input clocking options. For CMOS-compatible clocks or self-clocking, the level-shift terminal is at V _{CC-} and for TTL-compatible clocks, the level-shift terminal is at mid-supply.
V _{CC+}	7	I	Positive supply voltage terminal
V _{CC-}	4	I	Negative supply voltage terminal

TEXAS
INSTRUMENTS

T-64-05

**TLC04/MF4A-50, TLC14/MF4A-100
BUTTERWORTH FOURTH-ORDER LOW-PASS
SWITCHED-CAPACITOR FILTERS**

absolute maximum ratings over operating free-air temperature range (unless otherwise noted)

Supply voltage, $V_{CC\pm}$ (see Note 1)	± 7 V
Operating free-air temperature range: TLC04M/MF4A-50M, TLC14M/MF4A-100M	-55°C to 125°C
TLC04I/MF4A-50I, TLC14I/MF4A-100I	-40°C to 85°C
TLC04C/MF4A-50C, TLC14C/MF4A-100C	0°C to 70°C
Storage temperature	-65°C to 150°C
Lead temperature 1,6 mm (1/16 inch) from case for 10 seconds	260°C

NOTE 1: All voltage values are with respect to the AGND terminal.

recommended operating conditions

		TLC04/MF4A-50		TLC14/MF4A-100		UNIT	
		MIN	MAX	MIN	MAX		
V_{CC+}	Positive supply voltage	2.25	6	2.25	6	V	
V_{CC-}	Negative supply voltage	-2.25	-6	-2.25	-6	V	
V_{IH}	High-level input voltage	2		2		V	
V_{IL}	Low-level input voltage		0.8		0.8	V	
f_{clock}	Clock frequency (see Note 2)	$V_{CC\pm} = \pm 2.5$ V	5	1.5×10^6	5	1.5×10^6	Hz
		$V_{CC\pm} = \pm 5$ V	5	2×10^6	5	2×10^6	
f_{co}	Cutoff frequency (see Note 3)	0.1	40×10^3	0.05	20×10^3	Hz	
T_A	Operating free-air temperature	TLC04M/MF4A-50M, TLC14M/MF4A-100M	-55	125	-55	125	$^{\circ}\text{C}$
		TLC04I/MF4A-50I, TLC14I/MF4A-100I	-40	85	-40	85	
		TLC04C/MF4A-50C, TLC14C/MF4A-100C	0	70	0	70	

- NOTES: 2. Above 250 kHz, the input clock duty cycle should be 50% to allow the operational amplifiers the maximum time to settle while processing analog samples.
3. The cutoff frequency is defined as the frequency where the response is 3.01 dB less than the dc gain of the filter.

TLC04/MF4A-50, TLC14/MF4A-100
BUTTERWORTH FOURTH-ORDER LOW-PASS
SWITCHED-CAPACITOR FILTERS

T-64-05

electrical characteristics over recommended operating free-air temperature range, $V_{CC+} = 2.5\text{ V}$,
 $V_{CC-} = -2.5\text{ V}$, $f_{\text{clock}} \leq 250\text{ kHz}$ (unless otherwise noted)

filter section

PARAMETER	TEST CONDITIONS	TLC04/MF4A-50			TLC14/MF4A-100			UNIT
		MIN	TYP†	MAX	MIN	TYP†	MAX	
V_{OO} Output voltage offset		25			50			mV
V_{OM} Peak output voltages	$R_L = 10\text{ k}\Omega$	V_{OM+}	1.8	2	1.8	2	V	
		V_{OM-}	-1.25	-1.7	-1.25	-1.7		
I_{OS} Short-circuit output current	Source	$T_A = 25^\circ\text{C}$, See Note 4			-0.5			mA
	Sink				4			
I_{CC} Supply current	$f_{\text{clock}} = 250\text{ kHz}$	1.2	2.25	1.2	2.25	mA		

NOTE 4: I_{OS} (source current) is measured by forcing the output to its maximum positive voltage and then shorting the output to the negative supply (V_{CC-}) terminal. I_{OS} (sink current) is measured by forcing the output to its maximum negative voltage and then shorting the output to the positive supply (V_{CC+}) terminal.

operating characteristics over recommended operating free-air temperature range, $V_{CC+} = 2.5\text{ V}$,
 $V_{CC-} = -2.5\text{ V}$ (unless otherwise noted)

PARAMETER	TEST CONDITIONS	TLC04/MF4A-50			TLC14/MF4A-100			UNIT	
		MIN	TYP†	MAX	MIN	TYP†	MAX		
Maximum clock frequency, f_{max}	See Note 2	1.5	3	1.5	3	MHz			
Clock-to-cutoff-frequency ratio ($f_{\text{clock}}/f_{\text{co}}$)	$f_{\text{clock}} \leq 250\text{ kHz}$, $T_A = 25^\circ\text{C}$	49.27	50.07	50.87	99	100	101		
Temperature coefficient of clock-to-cutoff frequency ratio	$f_{\text{clock}} \leq 250\text{ kHz}$	± 25			± 25			ppm/ $^\circ\text{C}$	
Frequency response above and below cutoff frequency (see Note 5)	$f_{\text{co}} = 5\text{ kHz}$, $f_{\text{clk}} = 250\text{ kHz}$, $T_A = 25^\circ\text{C}$	$f = 6\text{ kHz}$	-7.9	-7.57	-7.1			dB	
		$f = 4.5\text{ kHz}$	-1.7	-1.46	-1.3				
	$f_{\text{co}} = 2.5\text{ kHz}$, $f_{\text{clk}} = 250\text{ kHz}$, $T_A = 25^\circ\text{C}$	$f = 3\text{ kHz}$				-7.9	-7.42	-7.1	dB
		$f = 2.25\text{ kHz}$				-1.7	-1.51	-1.3	
Dynamic range (see Note 6)	$T_A = 25^\circ\text{C}$	80			78			dB	
Stop-band frequency attenuation at $2 f_{\text{co}}$	$f_{\text{clock}} \leq 250\text{ kHz}$	24	25	24	25	dB			
DC voltage amplification	$f_{\text{clock}} \leq 250\text{ kHz}$, $R_S \leq 2\text{ k}\Omega$	-0.15	0	0.15	-0.15	0	0.15	dB	
Peak-to-peak clock feedthrough voltage	$T_A = 25^\circ\text{C}$	5			5			mV	

† All typical values are at $T_A = 25^\circ\text{C}$.

NOTES: 2. Above 250 kHz, the input clock duty cycle should be 50% to allow the operational amplifiers the maximum time to settle while processing analog samples.

5. The frequency responses at f are referenced to a dc gain of 0 dB.

6. The dynamic range is referenced to 1.06 V rms (1.5 V peak) where the wideband noise over a 30-kHz bandwidth is typically 106 μV rms for the TLC04/MF4A-50 and 135 μV rms for the TLC14/MF4A-100.

TEXAS
INSTRUMENTS

POST OFFICE BOX 655303 • DALLAS, TEXAS 75265

T-64-05

TLC04/MF4A-50, TLC14/MF4A-100
BUTTERWORTH FOURTH-ORDER LOW-PASS
SWITCHED-CAPACITOR FILTERS

electrical characteristics over recommended operating free-air temperature range, $V_{CC+} = 5\text{ V}$,
 $V_{CC-} = -5\text{ V}$, $f_{\text{clock}} \leq 250\text{ kHz}$, (unless otherwise noted)

filter section

PARAMETER	TEST CONDITIONS	TLC04/MF4A-50		TLC14/MF4A-100		UNIT	
		MIN	TYP†	MAX	MIN		TYP†
V_{OO} Output voltage offset		150		200		mV	
V_{OM} Peak output voltages	V_{OM+}	$R_L = 10\text{ k}\Omega$	3.75	4.3	3.75	4.5	V
	V_{OM-}		-3.75	-4.1	-3.75	-4.1	
I_{OS} Short-circuit output current	Source	$T_A = 25^\circ\text{C}$, See Note 4	-2		-2		mA
	Sink		5		5		
I_{CC} Supply current	$f_{\text{clock}} = 250\text{ kHz}$	1.8	3	1.8	3	mA	
k_{sys} Supply voltage sensitivity (see Figures 1 and 2)		-30		-30		dB	

NOTE 4: I_{OS} (source current) is measured by forcing the output to its maximum positive voltage and then shorting the output to the negative supply (V_{CC-}) terminal. I_{OS} (sink current) is measured by forcing the output to its maximum negative voltage and then shorting the output to the positive supply (V_{CC+}) terminal.

clocking section

PARAMETER	TEST CONDITIONS‡	MIN	TYP†	MAX	UNIT
V_{T+} Positive-going input threshold voltage	$V_{CC+} = 10\text{ V}$, $V_{CC-} = 0$	6.1	7	8.9	V
	$V_{CC+} = 5\text{ V}$, $V_{CC-} = 0$	3.1	3.5	4.4	
V_{T-} Negative-going input threshold voltage	$V_{CC+} = 10\text{ V}$, $V_{CC-} = 0$	1.3	3	3.8	V
	$V_{CC+} = 5\text{ V}$, $V_{CC-} = 0$	0.6	1.5	1.9	
V_{hys} , Hysteresis ($V_{T+} - V_{T-}$)	$V_{CC+} = 10\text{ V}$, $V_{CC-} = 0$	2.3	4	7.6	V
	$V_{CC+} = 5\text{ V}$, $V_{CC-} = 0$	1.2	2	3.8	
V_{OH} High-level output voltage	$V_{CC} = 10\text{ V}$	9		V	
	$V_{CC} = 5\text{ V}$	4.5			
V_{OL} Low-level output voltage	$V_{CC} = 10\text{ V}$	1		V	
	$V_{CC} = 5\text{ V}$	0.5			
Input leakage current	$V_{CC} = 10\text{ V}$	Level Shift pin at mid-supply,		2	μA
	$V_{CC} = 5\text{ V}$	$T_A = 25^\circ\text{C}$		2	
Output current	$V_{CC} = 10\text{ V}$	CLKR and CLKIN		-3	mA
	$V_{CC} = 5\text{ V}$	shorted to V_{CC-}		-0.75	
Output current	$V_{CC} = 10\text{ V}$	CLKR and CLKIN		3	mA
	$V_{CC} = 5\text{ V}$	shorted to V_{CC+}		0.75	

†All typical values are at $T_A = 25^\circ\text{C}$.

‡ $V_{CC} = V_{CC+} - V_{CC-}$

TLC04/MF4A-50, TLC14/MF4A-100
BUTTERWORTH FOURTH-ORDER LOW-PASS
SWITCHED-CAPACITOR FILTERS

T-64-05

operating characteristics over recommended operating free-air temperature range, $V_{CC+} = 5 V$,
 $V_{CC-} = -5 V$ (unless otherwise noted)

PARAMETER	TEST CONDITIONS	TLC04/MF4A-50			TLC14/MF4A-100			UNIT	
		MIN	TYP†	MAX	MIN	TYP†	MAX		
Maximum clock frequency, f_{max} (see Note 2)		2	4		2	4		MHz	
Clock-to-cutoff-frequency ratio (f_{clock}/f_{co})	$f_{clock} \leq 250 \text{ kHz}$, $T_A = 25^\circ\text{C}$	49.58	49.98	50.38	99	100	101		
Temperature coefficient of clock-to-cutoff frequency ratio	$f_{clock} \leq 250 \text{ kHz}$	±15			±15			ppm/°C	
Frequency response above and below cutoff frequency (see Note 5)	$f_{co} = 5 \text{ kHz}$, $f_{clk} = 250 \text{ kHz}$, $T_A = 25^\circ\text{C}$	$f = 6 \text{ kHz}$	-7.9	-7.57	-7.1			dB	
		$f = 4.5 \text{ kHz}$	-1.7	-1.44	-1.3				
	$f_{co} = 2.5 \text{ kHz}$, $f_{clk} = 250 \text{ kHz}$, $T_A = 25^\circ\text{C}$	$f = 3 \text{ kHz}$				-7.9	-7.42	-7.1	dB
		$f = 2.25 \text{ kHz}$				-1.7	-1.51	-1.3	
Dynamic range (see Note 7)	$T_A = 25^\circ\text{C}$	86			84			dB	
Stop-band frequency attenuation at $2 f_{co}$	$f_{clock} \leq 250 \text{ kHz}$	24	25		24	25		dB	
DC voltage amplification	$f_{clock} \leq 250 \text{ kHz}$, $R_S \leq 2 \text{ k}\Omega$	-0.15	0	0.15	-0.15	0	0.15	dB	
Peak-to-peak clock feedthrough voltage	$T_A = 25^\circ\text{C}$	7			7			mV	

† All typical values are at $T_A = 25^\circ\text{C}$.

NOTES: 2. Above 250 kHz, the input clock duty cycle should be 50% to allow the operational amplifiers the maximum time to settle while processing analog samples.

5. The frequency responses at f are referenced to a dc gain of 0 dB.

7. The dynamic range is referenced to 2.82 V rms (4 V peak) where the wideband noise over a 30-kHz bandwidth is typically 142 μV rms for the TLC04/MF4A-50 and 178 μV rms for the TLC14/MF4A-100.

**TLC04/MF4A-50, TLC14/MF4A-100
BUTTERWORTH FOURTH-ORDER LOW-PASS
SWITCHED-CAPACITOR FILTERS**

TYPICAL CHARACTERISTICS

7-64-05

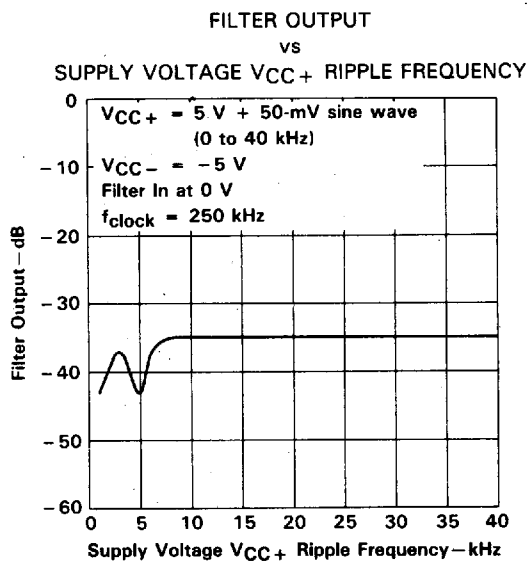

FIGURE 1

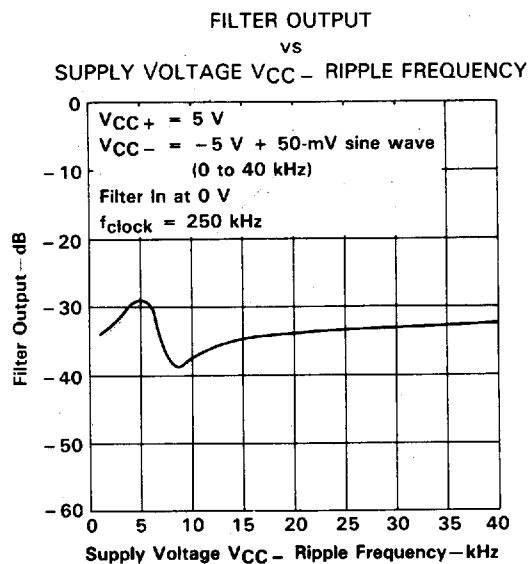

FIGURE 2

**TEXAS
INSTRUMENTS**

POST OFFICE BOX 655303 • DALLAS, TEXAS 75265

**TLC04/MF4A-50, TLC14/MF4A-100
BUTTERWORTH FOURTH-ORDER LOW-PASS
SWITCHED-CAPACITOR FILTERS**

T-64-05

TYPICAL APPLICATION DATA

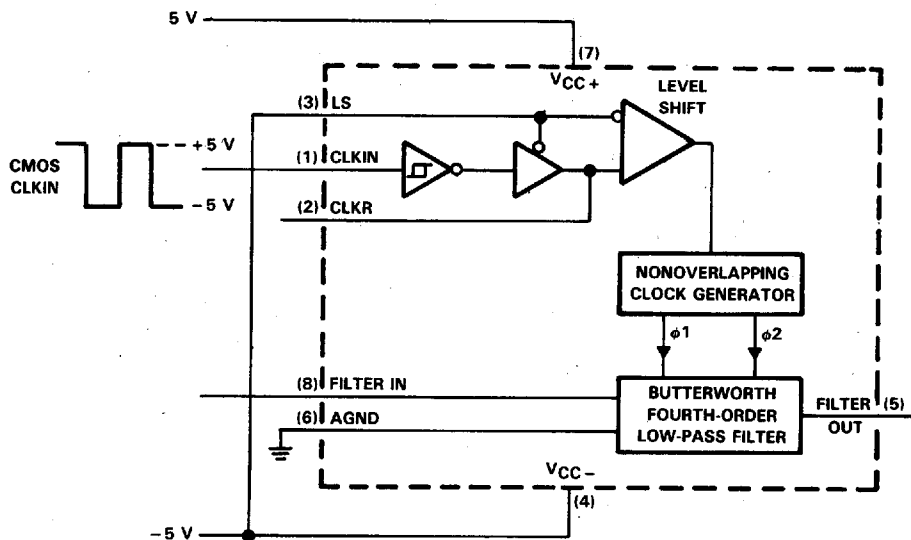

FIGURE 3. CMOS-CLOCK-DRIVEN, DUAL-SUPPLY OPERATION

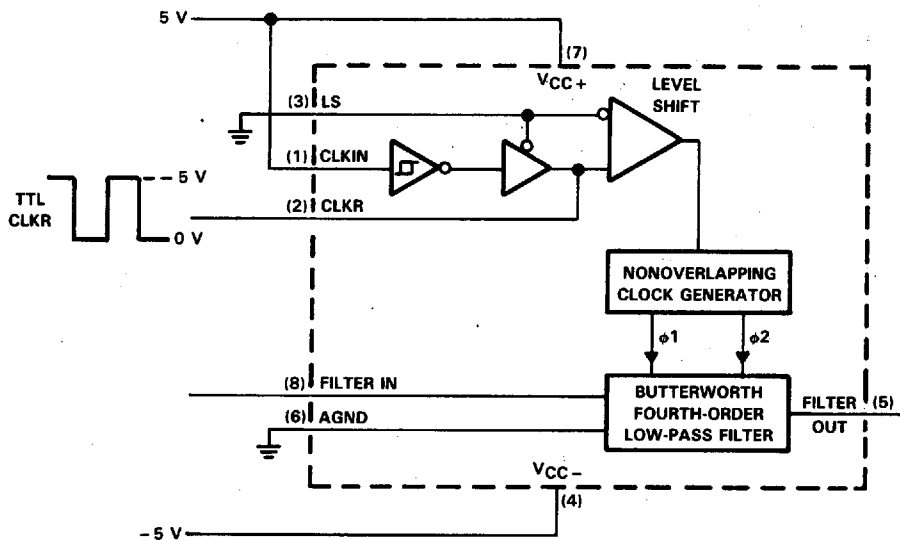

FIGURE 4. TTL-CLOCK-DRIVEN, DUAL-SUPPLY OPERATION



TLC04/MF4A-50, TLC14/MF4A-100
BUTTERWORTH FOURTH-ORDER LOW-PASS
SWITCHED-CAPACITOR FILTERS

TYPICAL APPLICATION DATA

T-64-05

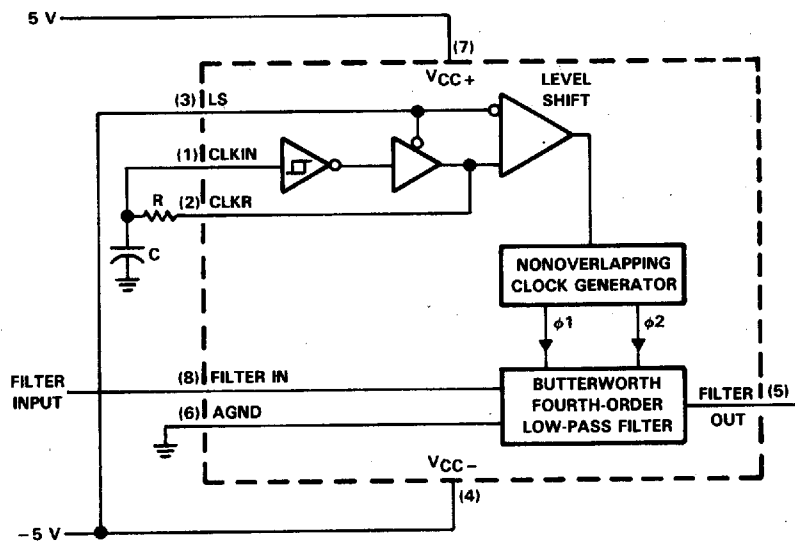

$$f_{\text{clock}} = \frac{1}{RC \times \ln \left[\left(\frac{V_{CC} - V_{T-}}{V_{CC} - V_{T+}} \right) \left(\frac{V_{T+}}{V_{T-}} \right) \right]}$$

For $V_{CC} = 10 \text{ V}$,

$$f_{\text{clock}} = \frac{1}{1.69 RC}$$

FIGURE 5. SELF-CLOCKING THROUGH SCHMITT-TRIGGER OSCILLATOR, DUAL-SUPPLY OPERATION

TLC04/MF4A-50, TLC14/MF4A-100
BUTTERWORTH FOURTH-ORDER LOW-PASS
SWITCHED-CAPACITOR FILTERS

T-64-05

TYPICAL APPLICATION DATA

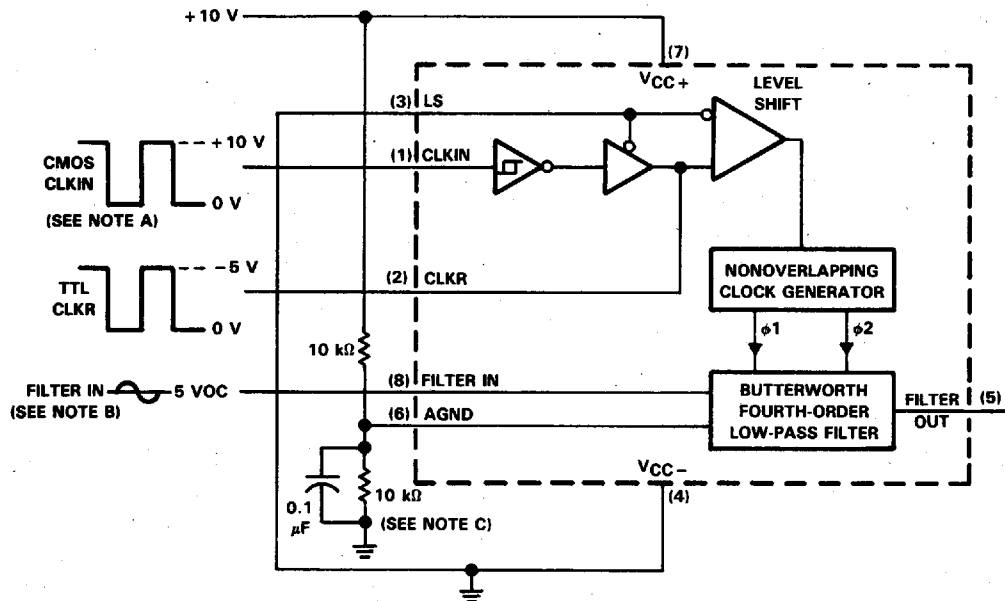

- NOTES: A. The external clock used must be of CMOS level because the clock is input to a CMOS Schmitt trigger.
 B. The Filter input signal should be dc-biased to mid-supply or ac-coupled to the terminal.
 C. The AGND terminal must be biased to mid-supply.

FIGURE 6. EXTERNAL-CLOCK-DRIVEN SINGLE-SUPPLY OPERATION

TEXAS
 INSTRUMENTS

POST OFFICE BOX 655303 • DALLAS, TEXAS 75265

TLC04/MF4A-50, TLC14/MF4A-100
BUTTERWORTH FOURTH-ORDER LOW-PASS
SWITCHED-CAPACITOR FILTERS

T-64-05

TYPICAL APPLICATION DATA

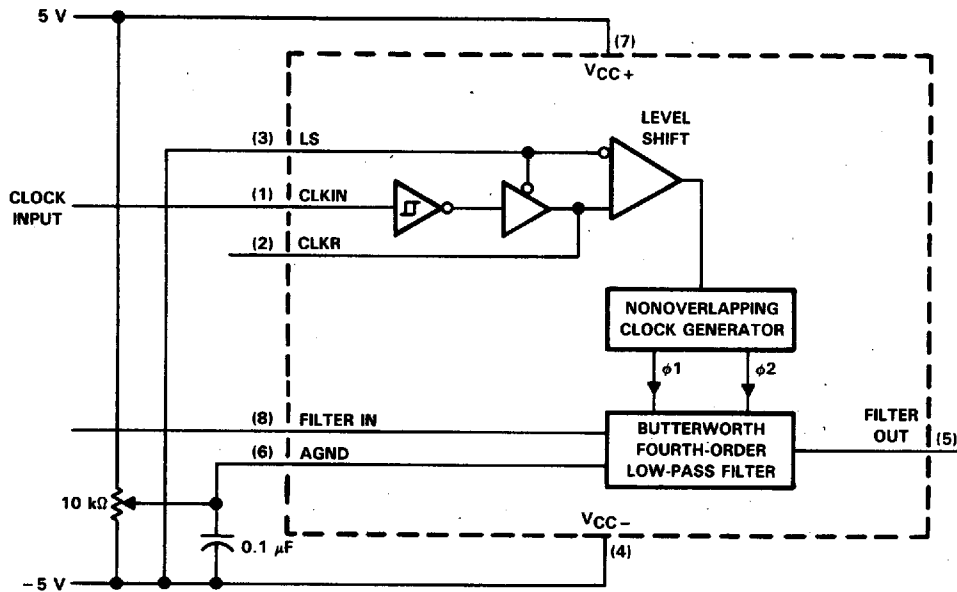

FIGURE 8. DC OFFSET ADJUSTMENT