

TL026C DIFFERENTIAL HIGH-FREQUENCY AMPLIFIER WITH AGC

SLFS007A – JUNE 1985 – REVISED JULY 1990

- Low Output Common-Mode Sensitivity to AGC Voltages
- Input and Output Impedances Independent of AGC Voltage
- Peak Gain . . . 38 dB Typ
- Wide AGC Range . . . 50 dB Typ
- 3-dB Bandwidth . . . 50 MHz
- Other Characteristics Similar to NE592 and μ A733

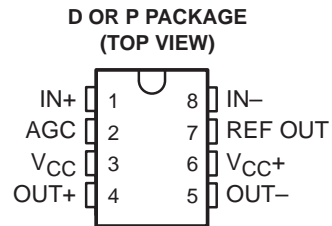

description

This device is a monolithic two-stage high-frequency amplifier with differential inputs and outputs.

Internal feedback provides wide bandwidth, low phase distortion, and excellent gain stability. Variable gain based on signal summation provides large AGC control over a wide bandwidth with low harmonic distortion. Emitter-follower outputs enable the device to drive capacitive loads. All stages are current-source biased to obtain high common-mode and supply-voltage rejection ratios. The gain may be electronically attenuated by applying a control voltage to the AGC pin. No external compensation components are required.

This device is particularly useful in TV and radio IF and RF AGC circuits, as well as magnetic-tape and disk-file systems where AGC is needed. Other applications include video and pulse amplifiers where a large AGC range, wide bandwidth, low phase shift, and excellent gain stability are required.

The TL026C is characterized for operation from 0°C to 70°C.

symbol

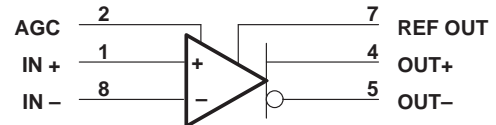

absolute maximum ratings over operating free-air temperature range (unless otherwise noted)†

Supply voltage, V_{CC+} (see Note 1)	8 V
Supply voltage, V_{CC-} (see Note 1)	-8 V
Differential input voltage	± 5 V
Common-mode input voltage	± 6 V
Output current	± 10 mA
Continuous total dissipation	See Dissipation Rating Table
Operating free-air temperature range	0°C to 70°C
Storage temperature range	-65°C to 150°C
Lead temperature range 1,6 mm (1/16 inch) from case for 10 seconds	260°C

† Stresses beyond those listed under absolute maximum ratings may cause permanent damage to the device. This is a stress rating only, and functional operation of the device at these or any other conditions beyond those indicated in the recommended operating conditions section of this specification is not implied. Exposure to absolute-maximum-rated conditions for extended periods may affect device reliability.

NOTE 1: All voltages are with respect to the midpoint of V_{CC+} and V_{CC-} except differential input and output voltages.

DISSIPATION RATING TABLE

PACKAGE	$T_A \leq 25^\circ\text{C}$ POWER RATING	OPERATING FACTOR ABOVE $T_A = 25^\circ\text{C}$	$T_A = 70^\circ\text{C}$ POWER RATING
D	725 mW	5.8 mW/°C	464 mW
P	1000 mW	8.0 mW/°C	640 mW

PRODUCTION DATA information is current as of publication date. Products conform to specifications per the terms of Texas Instruments standard warranty. Production processing does not necessarily include testing of all parameters.



POST OFFICE BOX 655303 • DALLAS, TEXAS 75265

Copyright © 1990, Texas Instruments Incorporated

TL026C

DIFFERENTIAL HIGH-FREQUENCY AMPLIFIER WITH AGC

SLFS007A – JUNE 1985 – REVISED JULY 1990

recommended operating conditions

	MIN	NOM	MAX	UNIT
Supply voltage, V_{CC+}	3	6	8	V
Supply voltage, V_{CC-}	-3	-6	-8	V
Operating free-air temperature range, T_A	0		70	°C

electrical characteristics at 25°C operating free-air temperature, $V_{CC+} = \pm 6$ V, $V_{AGC} = 0$, REF OUT pin open (unless otherwise specified)

PARAMETER	FIGURE	TEST CONDITIONS	MIN	TYP	MAX	UNIT
A_{VD}	1	$V_{O(PP)} = 3$ V, $R_L = 2$ k Ω	65	85	105	V/V
ΔA_{VD}	1	$V_{I(PP)} = 28.5$ mV, $R_L = 2$ k Ω , $V_{AGC} - V_{ref} = \pm 180$ mV		-50		dB
V_{ref}		$I_{ref} = -1$ mA to 100 μ A	1.3		1.5	V
BW	2	$V_{O(PP)} = 1$ V, $V_{AGC} - V_{ref} = \pm 180$ mV		50		MHz
I_{IO}				0.4	5	μ A
I_{IB}				10	30	μ A
V_{ICR}	3		± 1			V
V_{OC}	1	$R_L = \infty$	3.25	3.75	4.25	V
ΔV_{OC}	1	$V_{AGC} = 0$ to 2 V, $R_L = \infty$			300	mV
V_{OO}	1	$V_{ID} = 0$, $R_L = \infty$			0.75	V
$V_{O(PP)}$	1	$R_L = 2$ k Ω	3	4		V
r_i			10	30		k Ω
r_o				20		Ω
CMRR	3	$V_{IC} = \pm 1$ V, $f = 100$ kHz	60	86		dB
		$V_{IC} = \pm 1$ V, $f = 5$ mHz		60		
k_{SVR}	4	$\Delta V_{CC+} = \pm 0.5$ V, $\Delta V_{CC-} = \pm 0.5$ V	50	70		dB
V_n	4	BW = 1 kHz to 10 MHz		12		μ V
t_{pd}	2	$\Delta V_O = 1$ V		6	10	ns
t_r	2	$\Delta V_O = 1$ V		4.5	12	ns
$I_{sink(max)}$		$V_{ID} = 1$ V, $V_O = 3$ V	3	4		mA
I_{CC}		No load, No signal		22	27	mA



POST OFFICE BOX 655303 • DALLAS, TEXAS 75265

TL026C DIFFERENTIAL HIGH-FREQUENCY AMPLIFIER WITH AGC

SLFS007A – JUNE 1985 – REVISED JULY 1990

electrical characteristics over recommended operating free-air temperature range, $V_{CC\pm} = \pm 6\text{ V}$, $V_{AGC} = 0$, REF OUT pin open (unless otherwise specified)

PARAMETER	FIGURE	TEST CONDITIONS	MIN	TYP	MAX	UNIT
A_{VD}	1	$V_{O(PP)} = 3\text{ V}$, $R_L = 2\text{ k}\Omega$	55		115	V/V
I_{IO}					6	μA
I_{IB}					40	μA
V_{ICR}	3		± 1			V
V_{OO}	1	$V_{ID} = 0$, $R_L = \infty$			1.5	V
$V_{O(PP)}$	1	$R_L = 2\text{ k}\Omega$	2.8			V
r_i			8			$\text{k}\Omega$
CMRR	3	$V_{IC} = \pm 1\text{ V}$, $f = 100\text{ kHz}$	50			dB
kSVR ($\Delta V_{CC} / \Delta V_{IO}$)	4	$\Delta V_{CC+} = \pm 0.5\text{ V}$, $\Delta V_{CC-} = \pm 0.5\text{ V}$	50			dB
$I_{\text{sink(max)}}$		$V_{ID} = 1\text{ V}$, $V_O = 3\text{ V}$	2.8	4		mA
I_{CC}	1	No load, No signal			30	mA

PARAMETER MEASUREMENT INFORMATION

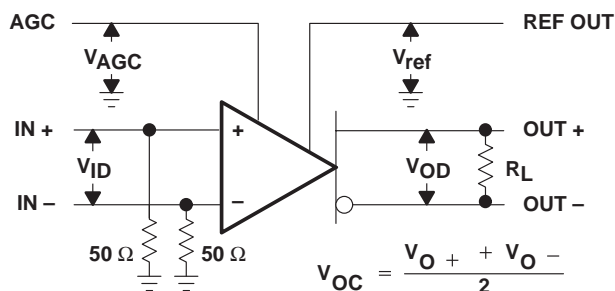

Figure 1. Test Circuit

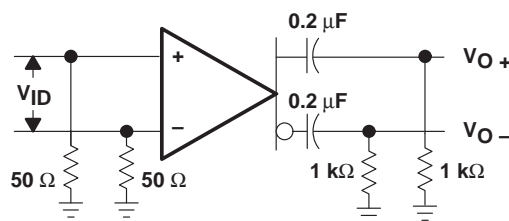

Figure 2. Test Circuit

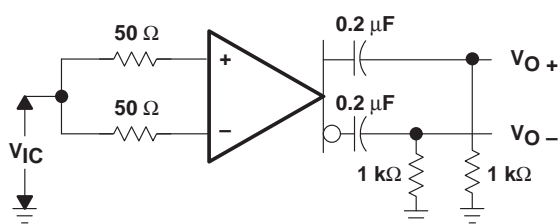

Figure 3. Test Circuit

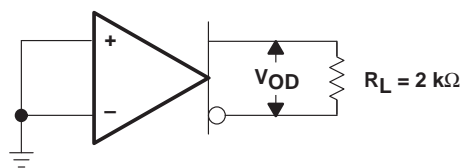

Figure 4. Test Circuit

TL026C DIFFERENTIAL HIGH-FREQUENCY AMPLIFIER WITH AGC

SLFS007A – JUNE 1985 – REVISED JULY 1990

TYPICAL CHARACTERISTICS

DIFFERENTIAL VOLTAGE AMPLIFICATION
VS
DIFFERENTIAL GAIN-CONTROL VOLTAGE

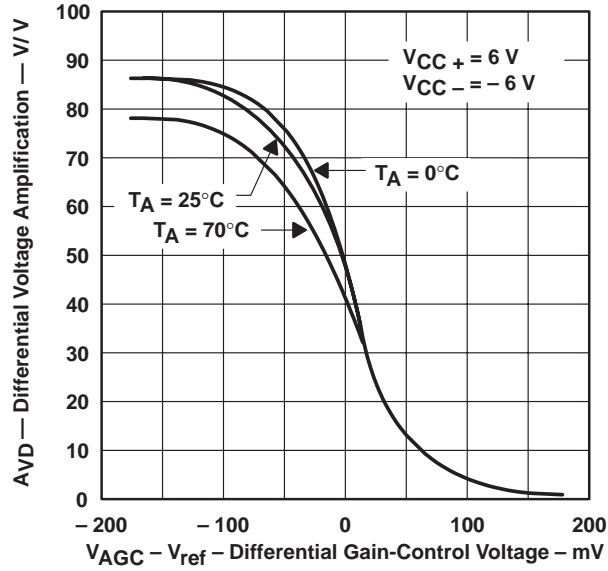

Figure 5

APPLICATION INFORMATION

gain characteristics

Figure 5 shows the differential voltage amplification versus the differential gain-control voltage ($V_{AGC} - V_{ref}$). V_{AGC} is the absolute voltage applied to the A_{GC} input and V_{ref} is the dc voltage at the REF OUT output. As V_{AGC} increases with respect to V_{ref} , the TL026C gain changes from maximum to minimum. As shown in Figure 5 for example, V_{AGC} would have to vary from approximately 180 mV less than V_{ref} to approximately 180 mV greater than V_{ref} to change the gain from maximum to minimum. The total signal change in V_{AGC} is defined by the following equation.

$$\begin{aligned}\Delta V_{AGC} &= V_{ref} + 180 \text{ mV} - (V_{ref} - 180 \text{ mV}) & (1) \\ \Delta V_{AGC} &= 360 \text{ mV}\end{aligned}$$

However, because V_{AGC} varies as the ac AGC signal varies and also differentially around V_{ref} , then V_{AGC} should have an ac signal component and a dc component. To preserve the dc and thermal tracking of the device, this dc voltage must be generated from V_{ref} . To apply proper bias to the AGC input, the external circuit used to generate V_{AGC} must combine these two voltages. Figures 6 and 7 show two circuits that will perform this operation and are easy to implement. The circuits use a standard dual operational amplifier for AGC feedback. By providing rectification and the required feedback gain, these circuits are also complete AGC systems.

circuit operation

Amplifier A1 amplifies and inverts the rectified and filtered AGC signal voltage V_C producing output voltage V1. Amplifier A2 is a differential amplifier that inverts V1 again and adds the scaled V_{ref} voltage. This conditioning makes V_{AGC} the sum of the signal plus the scaled V_{ref} . As the signal voltage increases, V_{AGC} increases and the gain of the TL026C is reduced. This maintains a constant output level.

feedback circuit equations

Following the AGC input signal (Figures 6 and 7) from the OUT output through the feedback amplifiers to the AGC input produces the following equations:

1. AC output to diode D1, assuming sinusoidal signals

$$V_O = V_{OP} (\sin(\omega t)) \quad (2)$$

where:

$$V_{OP} = \text{peak voltage of } V_O$$

2. Diode D1 and capacitor C1 output

$$V_C = V_{OP} - V_F \quad (3)$$

where:

$$V_F = \text{forward voltage drop of D1}$$

$$V_C = \text{voltage across capacitor C1}$$

3. A1 output

$$V_1 = -\frac{R_2}{R_1} V_C \quad (4)$$

4. A2 output ($R_3 = R_4$)

$$V_{AGC} = \frac{R_2}{R_1} V_C + 2 \frac{R_6}{R_5 + R_6} V_{ref} \quad (5)$$

TL026C

DIFFERENTIAL HIGH-FREQUENCY AMPLIFIER WITH AGC

SLFS007A – JUNE 1985 – REVISED JULY 1990

APPLICATION INFORMATION

Amplifier A2 inverts V1 producing a positive AGC signal voltage. Therefore, the input voltage to the TL026C AGC pin consists of an AGC signal equal to:

$$\frac{R_2}{R_1} V_C \quad (6)$$

and a dc voltage derived from V_{ref} , defined as the quiescent value of V_{AGC} .

$$V_{AGC}(q) = 2 \frac{R_6}{R_5 + R_6} V_{ref} \quad (7)$$

For the initial resistor calculations, V_{ref} is assumed to be typically 1.4 V making quiescent V_{AGC} approximately 1.22 V ($V_{AGC}(q) = V_{ref} - 180$ mV). This voltage allows the TL026C to operate at maximum gain under no-signal and low-signal conditions. In addition, with V_{ref} used as both internal and external reference, its variation from device to device automatically adjusts the overall bias and makes AGC operation essentially independent of the absolute value of V_{ref} . The resistor divider needs to be calculated only once and is valid for the full tolerance of V_{ref} .

output voltage limits (see Figures 6 and 7)

The output voltage level desired must fall within the following limits:

1. Because the data sheet minimum output swing is 3 V peak-to-peak using a 2-k Ω load resistor, the user-selected design limit for the peak output swing should not exceed 1.5 V.
2. The voltage drop of the rectifying diode determines the lower voltage limit. When a silicon diode is used, this voltage is approximately 0.7 V. The output voltage V_O must have sufficient amplitude to exceed the rectifying diode drop. Schottky diode can be used to reduce the V_O level required.

gain calculations for a peak output voltage of 1 V

A peak output voltage of 1 V was chosen for gain calculations because it is approximately midway between the limits of conditions 1 and 2 in the preceding paragraph.

Using equation 3 ($V_C = V_{OP} - V_d$), V_C is calculated as follows:

$$V_C = 1 \text{ V} - 0.7 \text{ V}$$

$$V_C = 0.3 \text{ V}$$

Therefore, the gain of A1 must produce a voltage V1 that is equal to or greater than the total change in V_{AGC} for maximum TL026C gain change.

With a total change in V_{AGC} of 360 mV and using equation 4, the calculation is as follows:

$$-\frac{V_1}{V_C} = \frac{\Delta V_{AGC}}{V_C} = \frac{R_2}{R_1} = \frac{0.36}{0.3} = 1.2$$

If R1 is 10 k Ω , R2 is 1.2 time R1 or 12 k Ω .

Since the output voltage for this circuit must be between 0.85 V and 1.3 V, the component values in Figures 6 and 7 provide a nominal 1-V peak output limit. This limit is the best choice to allow for temperature variations of the diode and minimum output voltage specification.



POST OFFICE BOX 655303 • DALLAS, TEXAS 75265

TL026C DIFFERENTIAL HIGH-FREQUENCY AMPLIFIER WITH AGC

SLFS007A – JUNE 1985 – REVISED JULY 1990

APPLICATION INFORMATION

The circuit values in Figures 6 and 7 will produce the best results in this general application. Because of rectification and device input constraints, the circuit in Figure 6 will not provide attenuation and has about 32 dB of control range. The circuit shown in Figure 7 will have approximately 25% variation in the peak output voltage limit due to the variation in gain of the TL592 device to device. In addition, if a lower output voltage is desired, the output of the TL026C can be used for approximately 40 mV of controlled signal.

considerations for the use of the TL026C

To obtain the most reliable results, RF breadboarding techniques must be used. A groundplane board should be used and power supplies should be bypassed with 0.1- μ F capacitors. Input leads and output leads should be as short as possible and separated from each other.

A peak input voltage greater than 200 mV will begin to saturate the input stages of the TL026C and, while the circuit is in the AGC mode, the output signal may become distorted.

To observe the output signal of TL026C or TL592, low-capacitance FET probes or the output voltage divider technique shown in Figure 6 should be used.

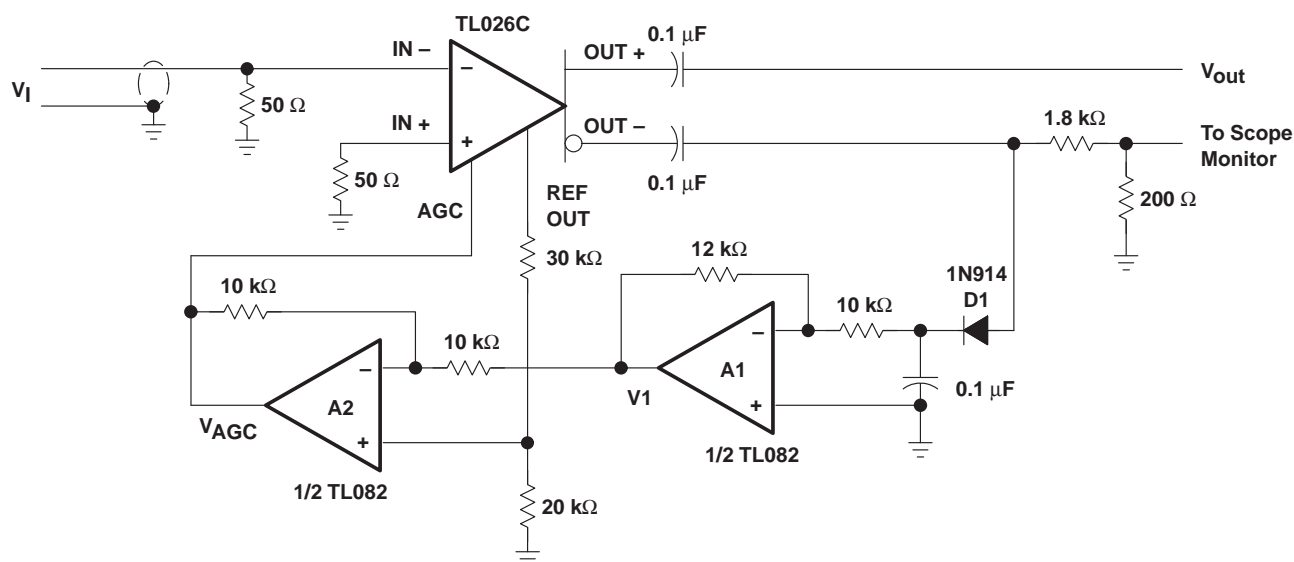

NOTE: $V_{CC+} = 6$ V and $V_{CC-} = -6$ V for TL026C and amplifiers A1 and A2.

Figure 6. Typical Application Circuit With No Attenuation

TL026C DIFFERENTIAL HIGH-FREQUENCY AMPLIFIER WITH AGC

SLFS007A – JUNE 1985 – REVISED JULY 1990

APPLICATION INFORMATION

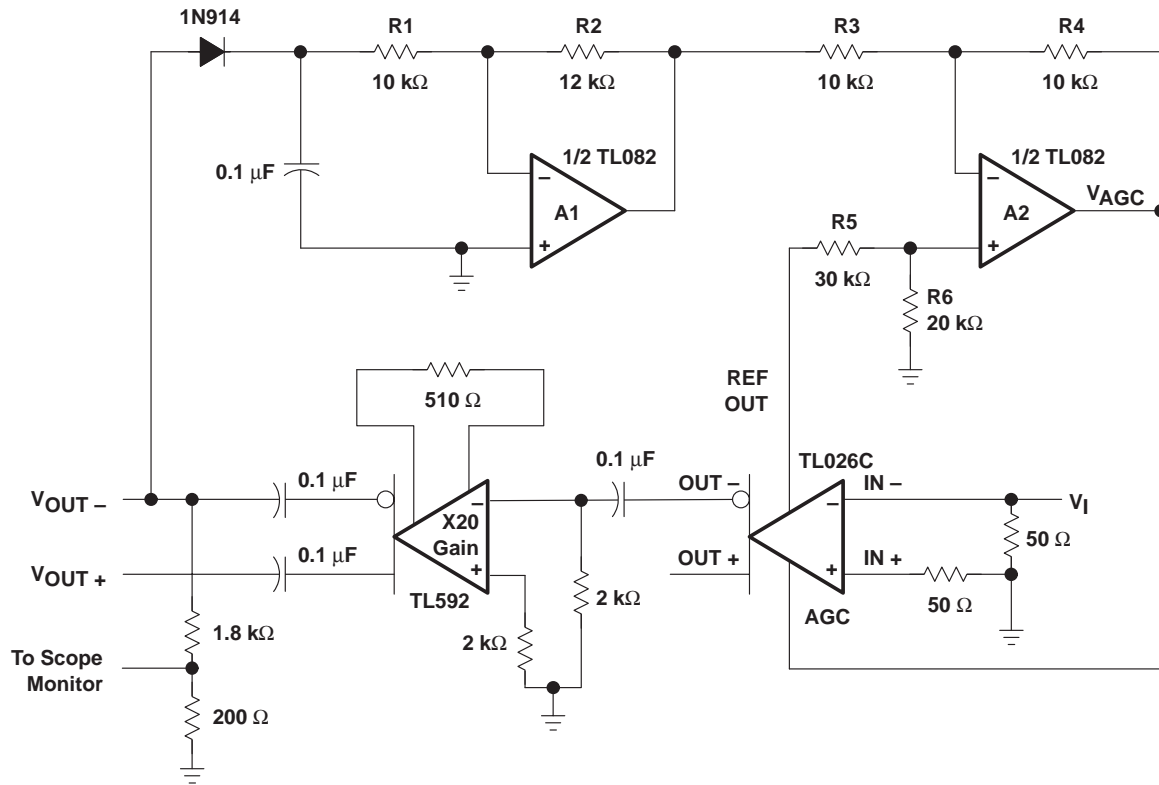

NOTE: $V_{CC+} = 6\text{ V}$ and $V_{CC-} = -6\text{ V}$ for TL026C and amplifiers A1 and A2.

Figure 7. Typical Application Circuit With Attenuation

IMPORTANT NOTICE

Texas Instruments and its subsidiaries (TI) reserve the right to make changes to their products or to discontinue any product or service without notice, and advise customers to obtain the latest version of relevant information to verify, before placing orders, that information being relied on is current and complete. All products are sold subject to the terms and conditions of sale supplied at the time of order acknowledgement, including those pertaining to warranty, patent infringement, and limitation of liability.

TI warrants performance of its semiconductor products to the specifications applicable at the time of sale in accordance with TI's standard warranty. Testing and other quality control techniques are utilized to the extent TI deems necessary to support this warranty. Specific testing of all parameters of each device is not necessarily performed, except those mandated by government requirements.

CERTAIN APPLICATIONS USING SEMICONDUCTOR PRODUCTS MAY INVOLVE POTENTIAL RISKS OF DEATH, PERSONAL INJURY, OR SEVERE PROPERTY OR ENVIRONMENTAL DAMAGE ("CRITICAL APPLICATIONS"). TI SEMICONDUCTOR PRODUCTS ARE NOT DESIGNED, AUTHORIZED, OR WARRANTED TO BE SUITABLE FOR USE IN LIFE-SUPPORT DEVICES OR SYSTEMS OR OTHER CRITICAL APPLICATIONS. INCLUSION OF TI PRODUCTS IN SUCH APPLICATIONS IS UNDERSTOOD TO BE FULLY AT THE CUSTOMER'S RISK.

In order to minimize risks associated with the customer's applications, adequate design and operating safeguards must be provided by the customer to minimize inherent or procedural hazards.

TI assumes no liability for applications assistance or customer product design. TI does not warrant or represent that any license, either express or implied, is granted under any patent right, copyright, mask work right, or other intellectual property right of TI covering or relating to any combination, machine, or process in which such semiconductor products or services might be or are used. TI's publication of information regarding any third party's products or services does not constitute TI's approval, warranty or endorsement thereof.