

SN5483A, SN54LS83A, SN7483A, SN74LS83A 4-BIT BINARY FULL ADDERS WITH FAST CARRY

MARCH 1974 - REVISED MARCH 1988

- Full-Carry Look-Ahead across the Four Bits
- Systems Achieve Partial Look-Ahead Performance with the Economy of Ripple Carry
- SN54283/SN74283 and SN54LS283/SN74LS283 Are Recommended For New Designs as They Feature Supply Voltage and Ground on Corner Pins to Simplify Board Layout

TYPE	TYPICAL ADD TIMES		TYPICAL POWER DISSIPATION PER 4-BIT ADDER
	TWO 8-BIT WORDS	TWO 16-BIT WORDS	
'83A	23 ns	43 ns	310 mW
'LS83A	28 ns	45 ns	95 mW

description

These improved full adders perform the addition of two 4-bit binary numbers. The sum (Σ) outputs are provided for each bit and the resultant carry (C_4) is obtained from the fourth bit. These adders feature full internal look-ahead across all four bits generating the carry term in ten nanoseconds typically. This provides the system designer with partial look-ahead performance at the economy and reduced package count of a ripple-carry implementation.

The adder logic, including the carry, is implemented in its true form meaning that the end-around carry can be accomplished without the need for logic or level inversion.

Designed for medium-speed applications, the circuits utilize transistor-transistor logic that is compatible with most other TTL families and other saturated low-level logic families.

Series 54 and 54LS circuits are characterized for operation over the full military temperature range of -55°C to 125°C , and Series 74 and 74LS circuits are characterized for operation from 0°C to 70°C .

logic symbol†

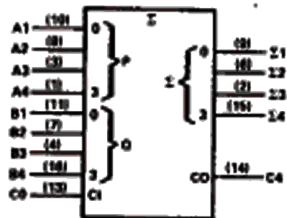

†This symbol is in accordance with ANSI/IEEE Std 91-1984 and IEC Publication 617-12.

Pin numbers are for D, J, N, and W packages.

SN5483A, SN54LS83A ... J OR W PACKAGE SN7483A ... N PACKAGE SN74LS83A ... D OR N PACKAGE

(TOP VIEW)

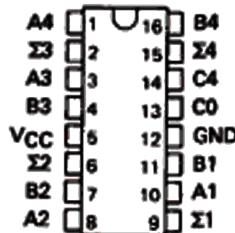

SN54LS83A ... FK PACKAGE

(TOP VIEW)

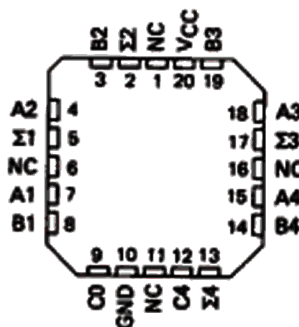

NC - No internal connection

FUNCTION TABLE

INPUT			OUTPUT					
			WHEN C ₀ = L			WHEN C ₀ = H		
A ₁	B ₁	C ₁	Σ ₁	Σ ₂	C ₂	Σ ₃	Σ ₄	C ₄
L	L	L	L	L	L	H	L	L
L	L	H	L	H	L	L	L	L
L	H	L	L	L	H	L	H	L
L	H	H	L	L	L	H	H	L
H	L	L	L	H	L	L	L	L
H	L	H	L	H	H	L	L	H
H	H	L	L	L	L	H	L	H
H	H	H	L	H	H	L	L	H
L	L	L	H	L	L	H	H	L
L	L	H	L	H	H	L	L	H
L	H	L	L	L	L	H	L	L
L	H	H	L	H	H	L	L	H
H	L	L	H	L	L	H	H	L
H	L	H	L	L	H	L	L	H
H	H	L	L	H	L	L	L	H
H	H	H	L	H	H	L	L	H

H = high level, L = low level

NOTE: Input conditions at A₁, B₁, A₂, B₂, and C₀ are used to determine outputs Σ₁ and Σ₂ and the value of the internal carry C₂. The values at C₂, A₃, B₃, A₄, and B₄ are then used to determine outputs Σ₃, Σ₄, and C₄.

PRODUCTION DATA documents contain information current as of publication date. Products conform to specifications per the terms of Texas Instruments standard warranty. Production processing does not necessarily include testing of all parameters.

TEXAS
INSTRUMENTS

POST OFFICE BOX 655012 • DALLAS, TEXAS 75265

2-257

SN5483A, SN54LS83A, SN7483A, SN74LS83A
4-BIT BINARY FULL ADDERS WITH FAST CARRY

schematics of inputs and outputs

2

TTL Devices

'83A

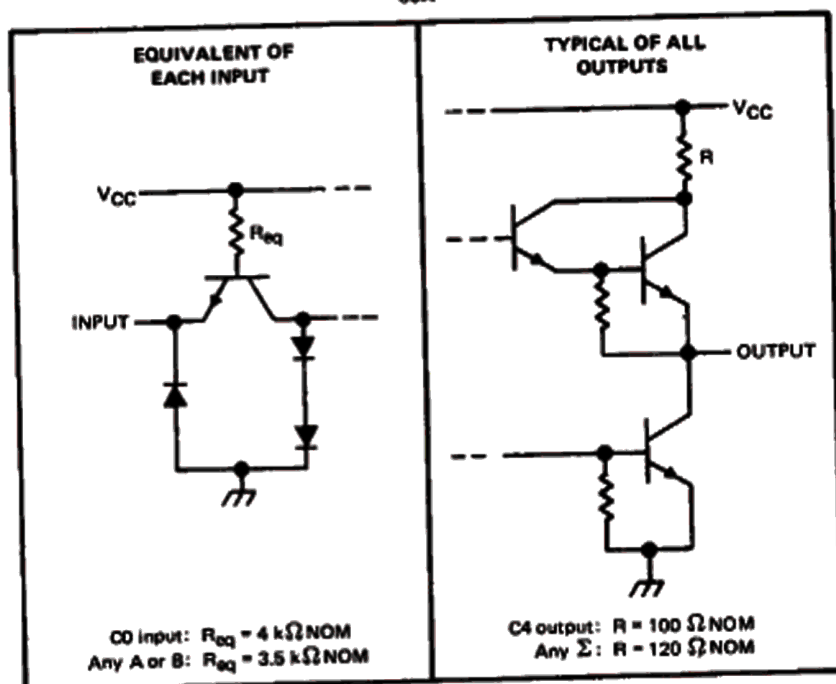

'LS83A

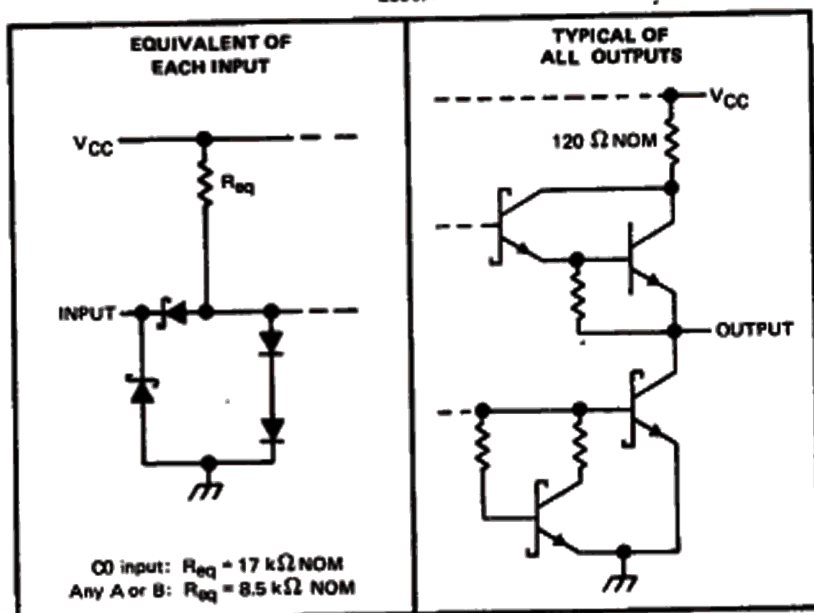

SN5483A, SN54LS83A, SN7483A, SN74LS83A 4-BIT BINARY FULL ADDERS WITH FAST CARRY

logic diagram (positive logic)

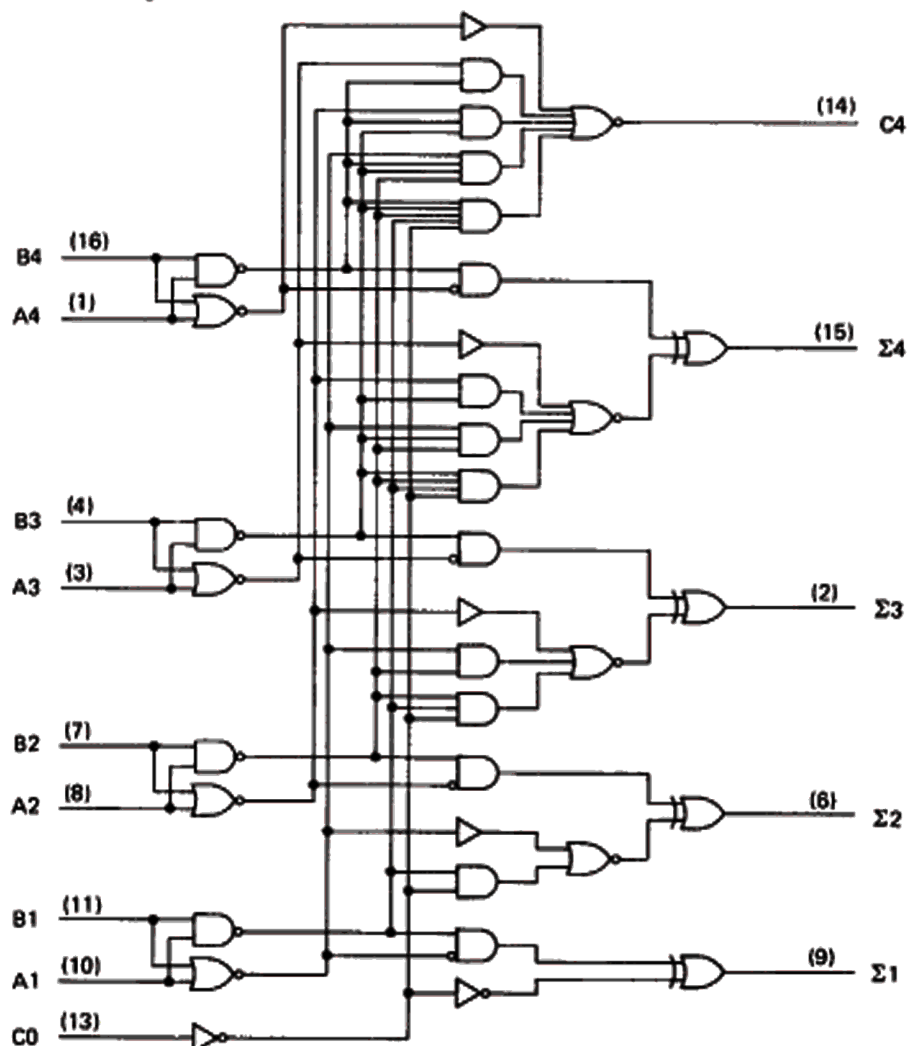

Pin numbers shown are for D, J, N, and W packages.

absolute maximum ratings over operating free-air temperature range (unless otherwise noted)

Supply voltage, V_{CC} (see Note 1)	7 V
Input voltage: '83A	5.5 V
'LS83A	7 V
Interemitter voltage (see Note 2)	5.5 V
Operating free-air temperature range: SN5483A, SN54LS83A	-55°C to 125°C
SN7483A, SN74LS83A	0°C to 70°C
Storage temperature range	-65°C to 150°C

NOTES: 1. Voltage values, except interemitter voltage, are with respect to network ground terminal.
2. This is the voltage between two emitters of a multiple-emitter transistor. This rating applies for the '83A only between the following pairs: A1 and B1, A2 and B2, A3 and B3, A4 and B4.

SN5483A, SN7483A 4-BIT BINARY FULL ADDERS WITH FAST CARRY

recommended operating conditions

	SN5483A			SN7483A			UNIT
	MIN	NOM	MAX	MIN	NOM	MAX	
Supply Voltage, V_{CC}	4.5	5	5.5	4.75	5	5.25	V
High-level output current, I_{OH}	Any output except C4			-800			μ A
	Output C4			-400			-400
Low-level output current, I_{OL}	Any output except C4			16			16
	Output C4			8			8
Operating free-air temperature, T_A	-55		125	0		70	$^{\circ}$ C

electrical characteristics over recommended operating free-air temperature range (unless otherwise noted)

PARAMETER	TEST CONDITIONS [†]	SN5483A			SN7483A			UNIT	
		MIN	TYP [‡]	MAX	MIN	TYP [‡]	MAX		
V_{IH} High-level input voltage		2			2			V	
V_{IL} Low-level input voltage				0.8			0.8	V	
V_{IK} Input clamp voltage	$V_{CC} = \text{MIN.}, I_I = -12 \text{ mA}$			-1.5			-1.5	V	
V_{OH} High-level output voltage	$V_{CC} = \text{MIN.}, V_{IH} = 2 \text{ V}, V_{IL} = 0.8 \text{ V}, I_{OH} = \text{MAX}$	2.4	3.4		2.4	3.4		V	
V_{OL} Low-level output voltage	$V_{CC} = \text{MIN.}, V_{IH} = 2 \text{ V}, V_{IL} = 0.8 \text{ V}, I_{OL} = \text{MAX}$		0.2	0.4		0.2	0.4	V	
I_I Input current at maximum input voltage	$V_{CC} = \text{MAX.}, V_I = 5.5 \text{ V}$			1			1	mA	
I_{IH} High-level input current	$V_{CC} = \text{MAX.}, V_I = 2.4 \text{ V}$			40			40	μ A	
I_{IL} Low-level input current	$V_{CC} = \text{MAX.}, V_I = 0.4 \text{ V}$			-1.6			-1.6	mA	
I_{OS} Short-circuit output current [§]	Any output except C4	$V_{CC} = \text{MAX}$			-20	-55	-18	-55	mA
	Output C4	$V_{CC} = \text{MAX}$			-20	-70	-18	-70	mA
I_{CC} Supply current	$V_{CC} = \text{MAX.},$ Outputs open	All B low, other inputs at 4.5 V			56			56	mA
		All inputs at 4.5 V			66			99	66

[†] For conditions shown as MIN or MAX, use the appropriate value specified under recommended operating conditions.

[‡] All typical values are at $V_{CC} = 5 \text{ V}, T_A = 25^{\circ}\text{C}$.

[§] Only one output should be shorted at a time.

switching characteristics, $V_{CC} = 5 \text{ V}, T_A = 25^{\circ}\text{C}$

PARAMETER [¶]	FROM (INPUT)	TO (OUTPUT)	TEST CONDITIONS	MIN	TYP	MAX	UNIT
t_{PLH}	C0	Any Σ	$C_L = 15 \text{ pF}, R_L = 400 \Omega,$ See Note 3	14	21	ns	
t_{PHL}				12	21		
t_{PLH}	A_i or B_i	Σ_i		16	24	ns	
t_{PHL}				16	24		
t_{PLH}	C0	C4	$C_L = 15 \text{ pF}, R_L = 780 \Omega,$ See Note 3	9	14	ns	
t_{PHL}				11	16		
t_{PLH}	A_i or B_i	C4		9	14	ns	
t_{PHL}				11	16		

[¶] t_{PLH} = propagation delay time, low-to-high-level output

t_{PHL} = propagation delay time, high-to-low-level output

NOTE 3: Load circuits and voltage waveforms are shown in Section 1.

2

TTL Devices

SN54LS83A, SN74LS83A 4-BIT BINARY FULL ADDERS WITH FAST CARRY

recommended operating conditions

	SN54LS83A			SN74LS83A			UNIT
	MIN	NOM	MAX	MIN	NOM	MAX	
Supply voltage, V_{CC}	4.5	5	5.5	4.75	5	5.25	V
High-level output current, I_{OH}			-400			-400	μ A
Low-level output current, I_{OL}			4			8	mA
Operating free-air temperature, T_A	-55		125	0		70	$^{\circ}$ C

electrical characteristics over recommended operating free-air temperature range (unless otherwise noted)

PARAMETER		TEST CONDITIONS [†]	SN54LS83A		SN74LS83A		UNIT	
			MIN	TYP [‡]	MAX	MIN		TYP [‡]
V_{IH}	High-level input voltage		2		2		V	
V_{IL}	Low-level input voltage			0.7		0.8	V	
V_{IK}	Input clamp voltage	$V_{CC} = \text{MIN}, I_I = -18 \text{ mA}$		-1.5		-1.5	V	
V_{OH}	High-level output voltage	$V_{CC} = \text{MIN}, V_{IH} = 2 \text{ V}, V_{IL} = V_{IL \text{ max}}, I_{OH} = -400 \mu\text{A}$	2.5	3.4	2.7	3.4	V	
V_{OL}	Low-level output voltage	$V_{CC} = \text{MIN}, V_{IH} = 2 \text{ V}, V_{IL} = V_{IL \text{ max}}, I_{OL} = 4 \text{ mA}$ $I_{OL} = 8 \text{ mA}$	0.25	0.4	0.25	0.4	V	
I_I	Input current at maximum input voltage	Any A or B		0.2		0.2	mA	
		C0		0.1		0.1		
I_{IH}	High-level input current	Any A or B		40		40	μ A	
		C0		20		20		
I_{IL}	Low-level input current	Any A or B		-0.8		-0.8	mA	
		C0		-0.4		-0.4		
I_{OS}	Short-circuit output current [§]	$V_{CC} = \text{MAX}$	-20	-100	-20	-100	mA	
I_{CC}	Supply current	$V_{CC} = \text{MAX},$ Outputs open	All inputs grounded	22	39	22	39	mA
			All B low, other inputs at 4.5 V	19	34	19	34	
			All inputs at 4.5 V	19	34	19	34	

[†]For conditions shown as MIN or MAX, use the appropriate value specified under recommended operating conditions.

[‡]All typical values are at $V_{CC} = 5 \text{ V}, T_A = 25^{\circ}\text{C}$.

[§]Only one output should be shorted at a time, and duration of the short-circuit should not exceed one second.

switching characteristics, $V_{CC} = 5 \text{ V}, T_A = 25^{\circ}\text{C}$

PARAMETER [¶]	FROM (INPUT)	TO (OUTPUT)	TEST CONDITIONS		MIN	TYP	MAX	UNIT
t_{PLH}	C0	Any Σ	$C_L = 15 \text{ pF},$ See Note 3	$R_L = 2 \text{ k}\Omega,$		16	24	ns
t_{PHL}						15	24	
t_{PLH}	A_i or B_i	Σ_i				15	24	ns
t_{PHL}						15	24	
t_{PLH}	C0	C4				11	17	ns
t_{PHL}						15	22	
t_{PLH}	A_i or B_i	C4				11	17	ns
t_{PHL}						12	17	

[¶] t_{PLH} = propagation delay time, low-to-high-level output

t_{PHL} = propagation delay time, high-to-low-level output

NOTE 3: Load circuits and voltage waveforms are shown in Section 1.

2
TTL Devices