

## PROGRAMMABLE 27-BIT DISPLAY SERIAL-INTERFACE TRANSMITTER

### FEATURES

- FlatLink™3G Serial-Interface Technology
- Compatible With FlatLink3G Receivers Such as SN65LVDS304
- Input Supports 24-bit RGB Video Mode Interface
- 24-Bit RGB Data, 3 Control Bits, 1 Parity Bit and 2 Reserved Bits Transmitted over 1 or 2 Differential Lines
- SubLVDS Differential Voltage Levels
- Effective Data Throughput up to 810 Mbps
- Three Operating Modes to Conserve Power
  - Active-Mode QVGA 17.4 mW (typ)
  - Active-Mode VGA 28.8 mW (typ)
  - Shutdown Mode  $\approx 0.5 \mu\text{A}$  (typ)
  - Standby Mode  $\approx 0.5 \mu\text{A}$  (typ)
- Bus Swap for Increased PCB Layout Flexibility
- 1.8-V Supply Voltage
- ESD Rating > 2 kV (HBM)
- Typical Application: Host-Controller to Display-Module Interface
- Pixel Clock Range of 4 MHz–30 MHz
- Failsafe on All CMOS Inputs
- Packaging: 80-Terminal, 5-mm  $\times$  5-mm  $\mu\text{BGA}$ ®

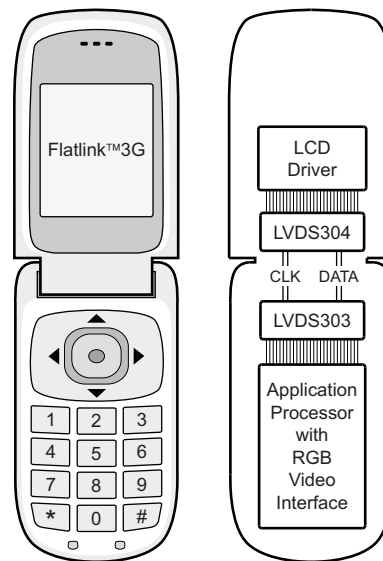
### DESCRIPTION

The SN65LVDS303 serializer device converts 27 parallel data inputs to one or two sub-low-voltage differential signaling (SubLVDS) serial outputs. It loads a shift register with 24 pixel bits and 3 control bits from the parallel CMOS input interface. In addition to the 27 data bits, the device adds a parity bit and two reserved bits into a 30-bit data word. Each word is latched into the device by the pixel clock (PCLK). The parity bit (odd parity) allows a receiver to detect single bit errors. The serial shift register is uploaded at 30 or 15 times the pixel-clock data rate, depending on the number of serial links used. A copy of the pixel clock is output on a separate differential output.

FPC cabling typically interconnects the SN65LVDS303 with the display. Compared to parallel signaling, the SN65LVDS303 outputs significantly reduce the EMI of the interconnect by over 20 dB.

The SN65LVDS303 supports three power modes (shutdown, standby and active) to conserve power. When transmitting, the PLL locks to the incoming pixel clock, PCLK, and generates an internal high-speed clock at the line rate of the data lines. The parallel data are latched on the rising or falling edge of PCLK, as selected by the external control signal CPOL. The serialized data is presented on the serial outputs D0 and D1, together with a recreated PCLK that is generated from the internal high-speed clock and output on CLK. If PCLK stops, the device enters a standby mode to conserve power.

The parallel (CMOS) input bus offers a bus-swap feature. The SWAP terminal configures the input order of the pixel data to be either R[7:0], G[7:0], B[7:0], VS, HS, DE or B[0:7], G[0:7], R[0:7], VS, HS, DE. This gives a PCB designer the flexibility to better match the bus to the host controller pinout or to put the transmitter device on the top side or the bottom side of the PCB.



Please be aware that an important notice concerning availability, standard warranty, and use in critical applications of Texas Instruments semiconductor products and disclaimers thereto appears at the end of this data sheet.

FlatLink is a trademark of Texas Instruments.

$\mu\text{BGA}$  is a registered trademark of Tessera, Inc..

All other trademarks are the property of their respective owners.

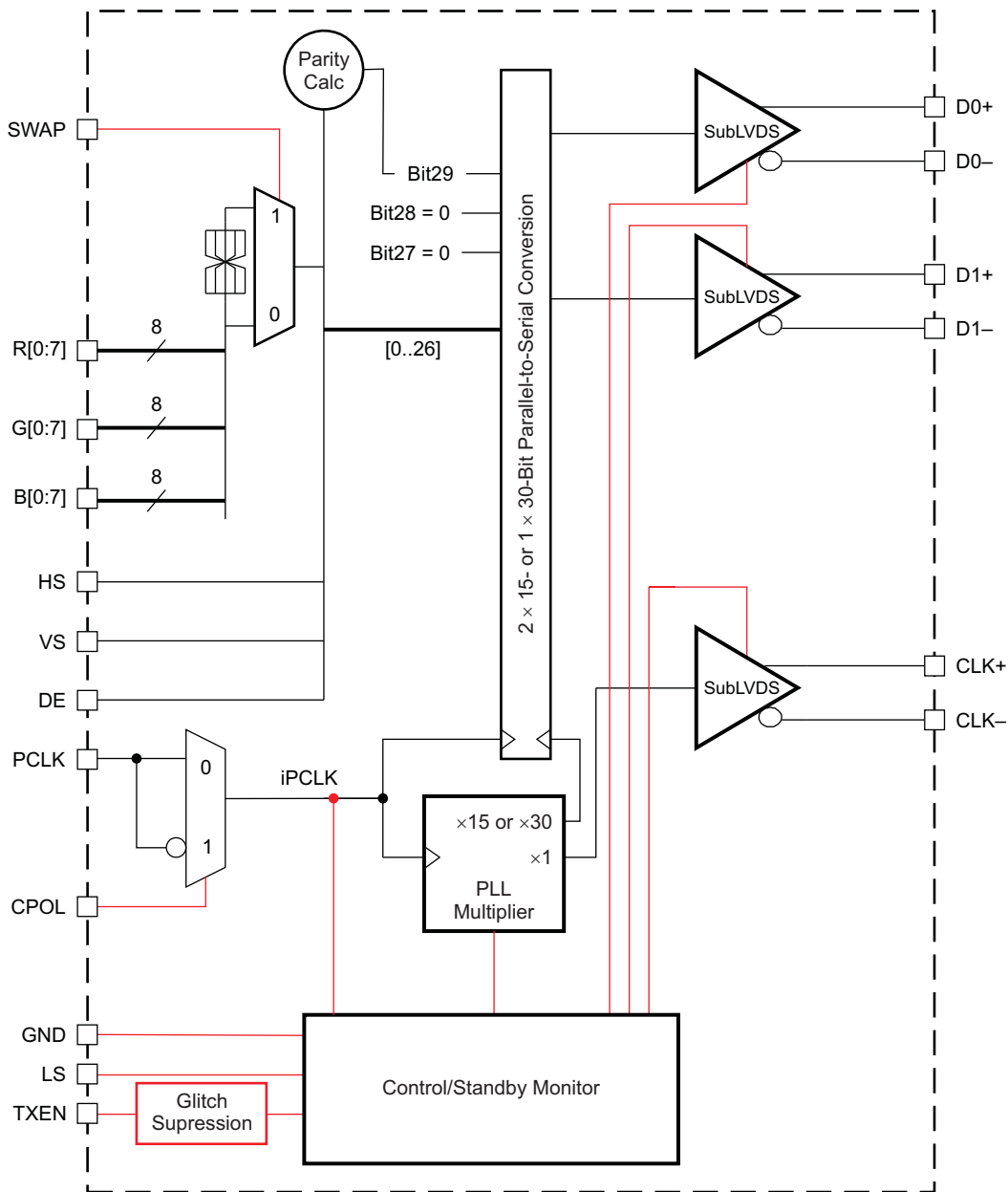


These devices have limited built-in ESD protection. The leads should be shorted together or the device placed in conductive foam during storage or handling to prevent electrostatic damage to the MOS gates.

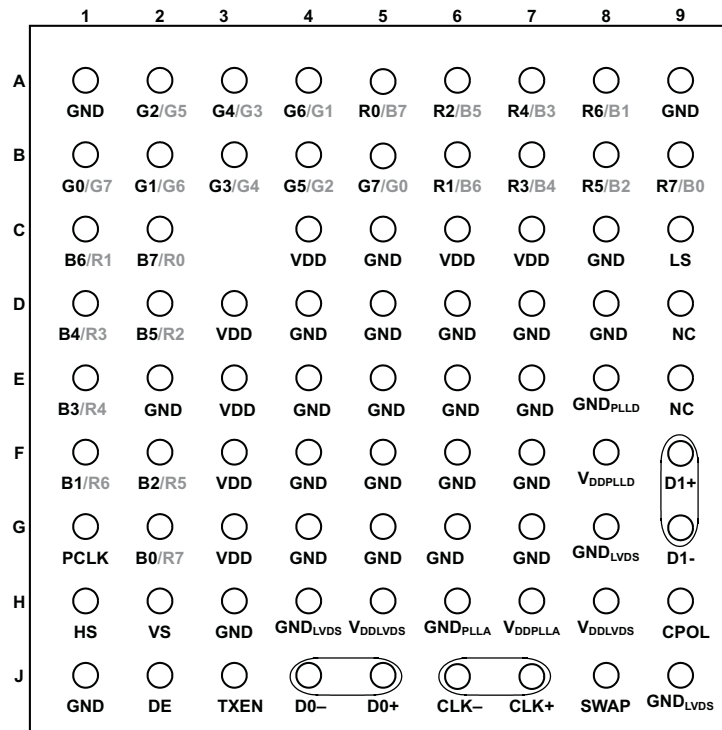
**DESCRIPTION (CONTINUED)**

The link select line, LS, controls whether one or two serial links are used. The TXEN input may be used to put the SN65LVDS303 in a shutdown mode. The TXEN input may be used to put the SN65LVDS303 in a shutdown mode. The SN65LVDS303 enters an active standby mode if the input clock, PCLK, stops. This minimizes power consumption without the need for controlling an external terminal. The SN65LVDS303 is characterized for operation over ambient air temperatures of  $-40^{\circ}\text{C}$  to  $85^{\circ}\text{C}$ . All CMOS inputs offer failsafe to protect the input from damage during power up and to avoid current flow into the device inputs during power up. An input voltage of up to 2.165 V can be applied to all CMOS inputs while  $V_{DD}$  is between 0 V and 1.65 V.

**Functional Block Diagram**



**PINOUT – TOP VIEW**



RGB Input pin assignment based on SWAP pin setting:

**SWAP=0/SWAP=1**

PINOUT – TOP VIEW (continued)

SWAP TERMINAL FUNCTIONALITY

The SWAP terminal allows the PCB designer to reverse the RGB bus, thus minimize potential signal crossovers due to signal routing. Figure 1 and Figure 2 show the RGB signal terminal assignment based on the SWAP terminal setting.

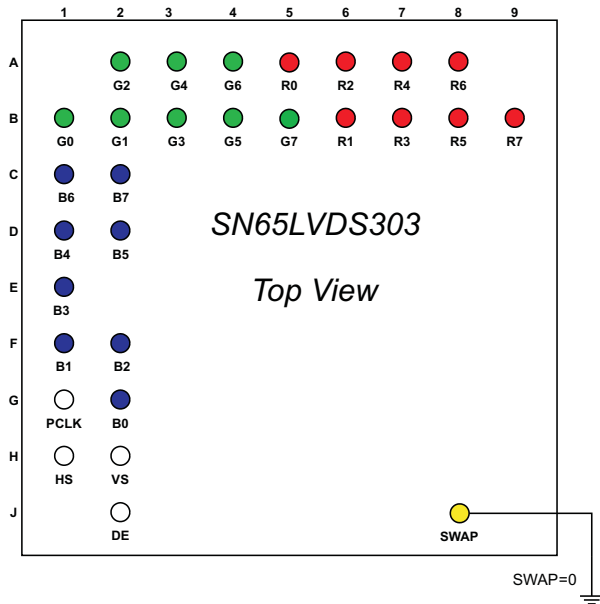


Figure 1. SWAP TERMINAL = 0

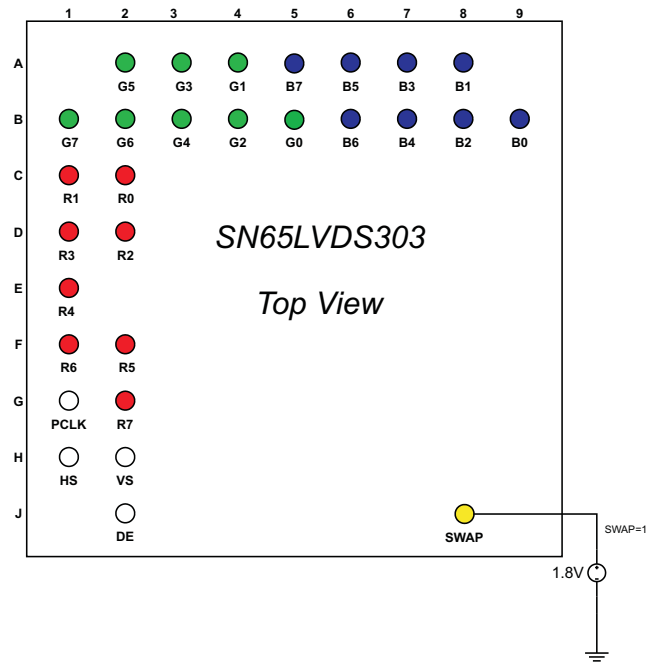


Figure 2. SWAP Terminal = 1

**Table 1. NUMERIC TERMINAL LIST**

TERMINAL	SWAP	SIGNAL	TERMINAL	SWAP	SIGNAL	TERMINAL	SWAP	SIGNAL
A1	—	GND	C1	0	B6	F1	0	B1
A2	0	G2		1	R1		1	R6
	1	G5	C2	0	B7	F2	0	B2
A3	0	G4		1	R0		1	R5
	1	G3	C3	UNPOPULATED		F3	—	VDD
A4	0	G6	C4	—	VDD	F4	—	GND
	1	G1	C5	—	GND	F5	—	GND
A5	0	R0	C6	—	VDD	F6	—	GND
	1	B7	C7	—	VDD	F7	—	GND
A6	0	R2	C8	—	GND	F8	—	V <sub>DDPLL</sub> D
	1	B5	C9	—	LS	F9	—	D1+
A7	0	R4	D1	0	B4	G1	—	PCLK
	1	B3		1	R3	G2	0	B0
A8	0	R6	D2	0	B5		1	R7
	1	B1		1	R2	G3	—	V <sub>DD</sub>
A9	—	GND	D3	—	VDD	G4	—	GND
B1	0	G0	D4	—	GND	G5	—	GND
	1	G7	D5	—	GND	G6	—	GND
B2	0	G1	D6	—	GND	G7	—	GND
	1	G6	D7	—	GND	G8	—	GND <sub>LVDS</sub>
B3	0	G3	D8	—	GND	G9	—	D1–
	1	G4	D9	—	NC	H1	—	HS
B4	0	G5	E1	0	B3	H2	—	VS
	1	G2		1	R4	H3	—	GND
B5	0	G7	E2	—	GND	H4	—	GND <sub>LVDS</sub>
	1	G0	E3	—	VDD	H5	—	V <sub>DDL</sub> VDS
B6	0	R1	E4	—	GND	H6	—	GND <sub>PLLA</sub>
	1	B6	E5	—	GND	H7	—	V <sub>DD</sub> PLLA
B7	0	R3	E6	—	GND	H8	—	V <sub>DDL</sub> VDS
	1	B4	E7	—	GND	H9	—	CPOL
B8	0	R5	E8	—	GND <sub>PLL</sub> D	J1	—	GND
	1	B2	E9	—	NC	J2	—	DE
B9	0	R7				J3	—	TXEN
	1	B0				J4	—	D0–
						J5	—	D0+
						J6	—	CLK–
						J7	—	CLK+
						J8	—	SWAP
						J9	—	GND <sub>LVDS</sub>

**Table 2. TERMINAL FUNCTIONS**

NAME	I/O	DESCRIPTION	
D0+, D0–	SubLVDS out	SubLVDS data link (active during normal operation)	
D1+, D1–		SubLVDS data link (active during normal operation when LS = high; high impedance if LS = low)	
CLK+, CLK–		SubLVDS output clock; clock polarity is fixed.	
R0–R7	CMOS in	Red pixel data (8); terminal assignment depends on SWAP terminal setting.	
G0–G7		Green pixel data (8); terminal assignment depends on SWAP terminal setting.	
B0–B7		Blue pixel data (8); terminal assignment depends on SWAP terminal setting.	
HS		Horizontal sync	
VS		Vertical sync	
DE		Data enable	
PCLK		Input pixel clock; rising or falling clock polarity is selected by control input CPOL.	
LS		Link select (determines active SubLVDS data links and PLL range); see <a href="#">Table 3</a> .	
TXEN		Disables the CMOS drivers and turns off the PLL, putting device in shutdown mode 1 – Transmitter enabled 0 – Transmitter disabled (shutdown)  Note: The TXEN input incorporates glitch-suppression logic to avoid device malfunction on short input spikes. It is necessary to pull TXEN high for longer than 10 $\mu$ s to enable the transmitter. It is necessary to pull the TXEN input low for longer than 10 $\mu$ s to disable the transmitter. At power up, the transmitter is enabled immediately if TXEN = 1 and disabled if TXEN = 0	
CPOL		CMOS in	Input clock polarity selection 0 – rising edge clocking 1 – falling edge clocking
SWAP		CMOS in	Bus swap. Swaps the bus terminals to allow device placement on top or bottom of PCB. See pinout drawing for terminal assignments. 0 – data input from B0...R7 1 – data input from R7...B0
V <sub>DD</sub>		Power supply <sup>(1)</sup>	Supply voltage
GND	Supply ground		
V <sub>DDL</sub> VDS	SubLVDS I/O supply voltage		
GND <sub>L</sub> VDS	SubLVDS ground		
V <sub>DD</sub> PLLA	PLL analog supply voltage		
GND <sub>PLLA</sub>	PLL analog GND		
V <sub>DD</sub> PLLD	PLL digital supply voltage		
GND <sub>PLLD</sub>	PLL digital GND		

(1) For a multilayer PCB, it is recommended to keep one common GND layer underneath the device and connect all ground terminals directly to this plane.

## FUNCTIONAL DESCRIPTION

### Serialization Modes

The SN65LVDS303 transmitter has two modes of operation controlled by link-select terminal LS. Table 3 shows the serializer modes of operation.

**Table 3. Logic Table: Link Select Operating Modes**

LS	Mode of Operation	Data Links Status
0	1-channel mode, 1ChM (30-bit serialization rate)	D0 active; D1 high-impedance
1	2-channel mode, 2ChM (15-bit serialization rate)	D0, D1 active

#### 1-Channel Mode

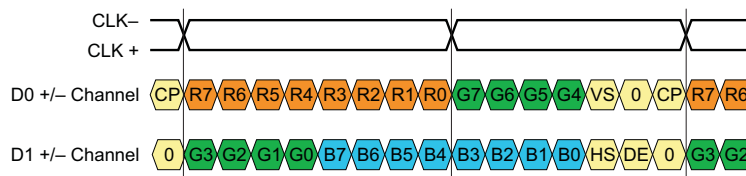
While LS is held low, the SN65LVDS303 transmits payload data over a single SubLVDS data pair, D0. The PLL locks to PCLK and internally multiplies the clock by a factor of 30. The internal high-speed clock is used to serialize (shift out) the data payload on D0. Two reserved bits and the parity bit are added to the data frame. Figure 3 illustrates the timing and the mapping of the data payload into the 30-bit frame. The internal high-speed clock is divided by a factor of 30 to recreate the pixel clock, and presented on the SubLVDS CLK output. While in this mode, the PLL can lock to a clock that is in the range of 4 MHz through 15 MHz. This mode is intended for smaller video display formats (e.g. QVGA to HVGA) that do not require the full bandwidth capabilities of the SN65LVDS303.



**Figure 3. Data and Clock Output in 1-Channel Mode (LS = Low).**

#### 2-Channel Mode

While LS is held high, the SN65LVDS303 transmits payload data over two SubLVDS data pairs, D0 and D1. The PLL locks to PCLK and internally multiplies it by a factor of 15. The internal high-speed clock is used to serialize the data payload on D0 and D1. Two reserved bits and the parity bit are added to the data frame. Figure 4 illustrates the timing and the mapping of the data payload into the 30-bit frame and how the frame becomes split into the two output channels. The internal high-speed clock is divided by 15 to recreate the pixel clock and presented on SubLVDS CLK. The PLL can lock to a clock that is in the range of 8 MHz through 30 MHz in this mode. Typical applications for using the 2-channel mode are HVGA and VGA displays.



**Figure 4. Data and Clock Output in 2-Channel Mode (LS = High).**

### Power-Down Modes

The SN65LVDS303 transmitter has two power-down modes to facilitate efficient power management.

#### Shutdown Mode

The SN65LVDS303 enters shutdown mode when the TXEN terminal is asserted low. This turns off all transmitter circuitry, including the CMOS input, PLL, serializer, and SubLVDS transmitter output stage. All outputs are high-impedance. Current consumption in shutdown mode is nearly zero.

## Standby Mode

The SN65LVDS303 enters the standby mode if TXEN is high and the PCLK input signal frequency is less than 500 kHz. All circuitry except the PCLK input monitor is shut down, and all outputs enter the high-impedance state. The current consumption in standby mode is very low. When the PCLK input signal is completely stopped, the  $I_{DD}$  current consumption is less than 10  $\mu$ A. The PCLK input must not be left floating.

### NOTE:

A floating (left open) CMOS input allows leakage currents to flow from  $V_{DD}$  to GND. To prevent large leakage current, a CMOS gate must be kept at a valid logic level, either  $V_{IH}$  or  $V_{IL}$ . This can be achieved by applying an external voltage of  $V_{IH}$  or  $V_{IL}$  to all SN65LVDS303 inputs.

## Active Modes

When TXEN is high and the PCLK input clock signal is faster than 3 MHz, the SN65LVDS303 enters the active mode. Current consumption in the active mode depends on operating frequency and the number of data transitions in the data payload.

## Acquire Mode (PLL Approaches Lock)

The PLL is enabled and attempts to lock to the input clock. All outputs remain in the high-impedance state. When the PLL monitor detects stable PLL operation, the device switches from the acquire mode to the transmit mode. For proper device operation, the pixel clock frequency must fall within the valid  $f_{PCLK}$  range specified under recommended operating conditions. If the pixel clock frequency is higher than 3 MHz but lower than  $f_{PCLK}(\min)$ , the SN65LVDS303 PLL is enabled. Under such conditions, it is possible for the PLL to lock temporarily to the pixel clock, causing the PLL monitor to release the device into transmit mode. If this happens, the PLL may or may not be properly locked to the pixel clock input, potentially causing data errors, frequency oscillation, and PLL deadlock (loss of VCO oscillation).

## Transmit Mode

After the PLL achieves lock, the device enters the normal transmit mode. The CLK terminal outputs a copy of PCLK. Based on the selected mode of operation, the D0 and D1 outputs carry the serialized data. In 1-channel mode, the D1 outputs remain in the high-impedance state.

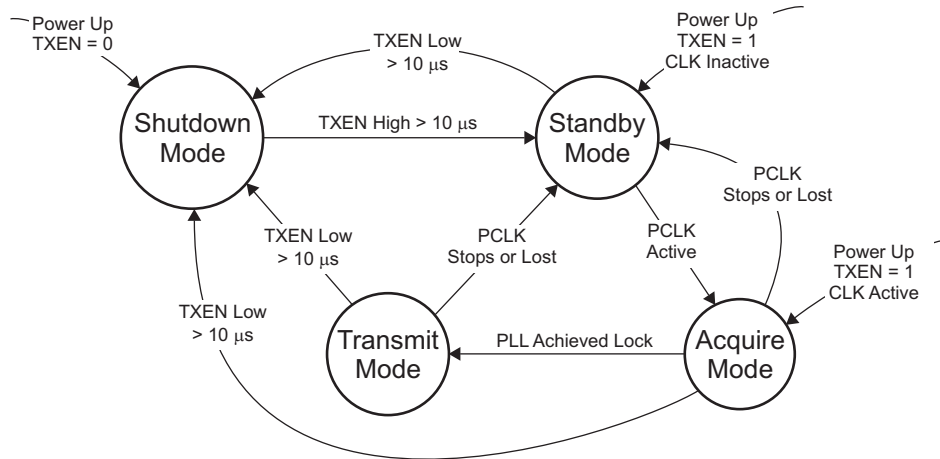
## Parity Bit Generation

The SN65LVDS303 transmitter calculates the parity of the transmit data word and sets the parity bit accordingly. The parity bit covers the 27-bit data payload consisting of 24 bits of pixel data plus VS, HS and DE. The two reserved bits are not included in the parity generation. Odd-parity bit signaling is used. The transmitter sets the parity bit if the sum of the 27 data bits results in an even number of ones. The parity bit is cleared otherwise. This allows the receiver to verify parity and detect single bit errors.



### Status Detect and Operating Modes Flow diagram

The SN65LVDS303 switches between the power saving and active modes in the following way:



**Figure 5. Status Detect and Operating Modes Flow Diagram**

**Table 4. Status Detect and Operating Modes Descriptions**

Mode	Characteristics	Conditions
Shutdown mode	Least amount of power consumption <sup>(1)</sup> (most circuitry turned off); all outputs are high-impedance.	TXEN is low. <sup>(1)(2)</sup>
Standby mode	Low power consumption (only clock activity circuit active; PLL is disabled to conserve power); all outputs are high-impedance.	TXEN is high; PCLK input signal is missing or inactive. <sup>(2)</sup>
Acquire mode	PLL tries to achieve lock; all outputs are high-impedance.	TXEN is high; PCLK input monitor detected input activity.
Transmit mode	Data transfer (normal operation); transmitter serializes data and transmits data on serial output; unused outputs remain high-impedance.	TXEN is high and PLL is locked to incoming clock.

(1) In shutdown mode, all SN65LVDS303 internal switching circuits (e.g., PLL, serializer, etc.) are turned off to minimize power consumption. The input stage of any input terminal remains active.

(2) Leaving inputs unconnected can cause random noise to toggle the input stage and potentially harm the device. All inputs must be tied to a valid logic level  $V_{IL}$  or  $V_{IH}$  during shutdown or standby mode.

**Table 5. Operating Mode Transitions**

MODE TRANSITION	USE CASE	TRANSITION SPECIFICS
Shutdown → standby	Drive TXEN high to enable transmitter	<ol style="list-style-type: none"> <li>1. TXEN high &gt; 10 <math>\mu</math>s</li> <li>2. Transmitter enters standby mode. <ol style="list-style-type: none"> <li>a. All outputs are high-impedance.</li> <li>b. Transmitter turns on clock input monitor.</li> </ol> </li> </ol>
Standby → acquire	Transmitter activity detected	<ol style="list-style-type: none"> <li>1. PCLK input monitor detects clock input activity.</li> <li>2. Outputs remain high-impedance.</li> <li>3. PLL circuit is enabled.</li> </ol>
Acquire → transmit	Link is ready to transfer data	<ol style="list-style-type: none"> <li>1. PLL is active and approaches lock.</li> <li>2. PLL achieved lock within 2 ms.</li> <li>3. Parallel data input latches into shift register.</li> <li>4. CLK output turns on.</li> <li>5. Selected data outputs turn on and send out first serial data bit.</li> </ol>
Transmit → standby	Request transmitter to enter standby mode by stopping PCLK	<ol style="list-style-type: none"> <li>1. PCLK Input monitor detects missing PCLK.</li> <li>2. Transmitter indicates standby, putting all outputs into high-impedance.</li> <li>3. PLL shuts down.</li> <li>4. PCLK activity input monitor remains active.</li> </ol>
Transmit/standby → shutdown	Turn off transmitter	<ol style="list-style-type: none"> <li>1. TXEN pulled low for longer than 10 <math>\mu</math>s</li> <li>2. Transmitter indicates standby, putting output CLK+ and CLK– into high-impedance state.</li> <li>3. Transmitter puts all other outputs into high-impedance state.</li> <li>4. Most IC circuitry is shut down for least power consumption.</li> </ol>

**ORDERING INFORMATION**

PART NUMBER	Package	SHIPPING METHOD
SN65LVDS303ZQER	ZQE	Reel

**ABSOLUTE MAXIMUM RATINGS<sup>(1)</sup>**

over operating free-air temperature range (unless otherwise noted)

	VALUE	UNIT	
Supply voltage range, $V_{DD}^{(2)}$ , $V_{DDPLL_A}$ , $V_{DDPLL_D}$ , $V_{DDLVD_S}$	–0.3 to 2.175	V	
Voltage range at any input or output terminal	When $V_{DDx} > 0$ V	–0.5 to 2.175	V
	When $V_{DDx} \leq 0$ V	–0.5 to $V_{DD} + 2.175$	V
Electrostatic discharge	Human-body model <sup>(3)</sup> (all terminals)	$\pm 3$	kV
	Charged-device model <sup>(4)</sup> (all terminals)	$\pm 500$	V
	Machine model <sup>(5)</sup> (all terminals)	$\pm 200$	
Continuous power dissipation	See <i>Dissipation Ratings</i> table		

(1) Stresses beyond those listed under *absolute maximum ratings* may cause permanent damage to the device. These are stress ratings only and functional operation of the device at these or any other conditions beyond those indicated under *recommended operating conditions* is not implied. Exposure to absolute maximum-rated conditions for extended periods may affect device reliability.

(2) All voltage values are with respect to the GND terminals.

(3) In accordance with JEDEC Standard 22, Test Method A114-A.

(4) In accordance with JEDEC Standard 22, Test Method C101.

(5) In accordance with JEDEC Standard 22, Test Method A115-A

## DISSIPATION RATINGS

PACKAGE	CIRCUIT BOARD MODEL	$T_A < 25^\circ\text{C}$	DERATING FACTOR <sup>(1)</sup> ABOVE $T_A = 25^\circ\text{C}$	$T_A = 85^\circ\text{C}$ POWER RATING
ZQE	Low-K <sup>(2)</sup>	592 mW	7.407 mW/°C	148 mW

(1) This is the inverse of the junction-to-ambient thermal resistance when board-mounted and with no air flow.

(2) In accordance with the low-K thermal metric definitions of EIA/JESD51-2.

## THERMAL CHARACTERISTICS

PARAMETER		TEST CONDITIONS		VALUE	UNIT
$P_D$ Device power dissipation	Typical	$V_{DDx} = 1.8\text{ V}$ , $T_A = 25^\circ\text{C}$ , 2-channel mode	PCLK at 4 MHz	14.4	mW
			PCLK at 30 MHz	38.2	
	Maximum	$V_{DDx} = 1.95\text{ V}$ , $T_A = -40^\circ\text{C}$	PCLK at 4 MHz	22.3	mW
			PCLK = 30 MHz	50.2	

## RECOMMENDED OPERATING CONDITIONS<sup>(1)</sup>

			MIN	NOM	MAX	UNIT
$V_{DD}$ $V_{DDPLLA}$ $V_{DDPLLD}$ $V_{DDLVDs}$	Supply voltages		1.65	1.8	1.95	V
$V_{DDn(PP)}$	Supply voltage noise magnitude 50 MHz (all supplies)	Test setup see <a href="#">Figure 11</a> $f(\text{noise}) = 1\text{ Hz to }2\text{ GHz}$			100	mV
$f_{PCLK}$	Pixel clock frequency	1-channel transmit mode, see <a href="#">Figure 3</a>	4		15	MHz
		2-channel transmit mode, see <a href="#">Figure 4</a>	8		30	
		Frequency threshold, standby mode to active mode <sup>(2)</sup> , see <a href="#">Figure 15</a>	0.5		3	
$t_{H \times f_{PCLK}}$	PCLK input duty cycle		0.33		0.67	
$T_A$	Operating free-air temperature		-40		85	°C
$t_{jit(per)PCLK}$	PCLK RMS period jitter <sup>(3)</sup>	Measured on PCLK input			5	ps-rms
$t_{jit(TJ)PCLK}$	PCLK total jitter				$0.05/f_{PCLK}$	s
$t_{jit(CC)PCLK}$	PCLK peak cycle-to-cycle jitter <sup>(4)</sup>				$0.02/f_{PCLK}$	s
<b>PCLK, R[0:7], G[0:7], B[0:7], VS, HS, DE, PCLK, LS, CPOL, TXEN, SWAP</b>						
$V_{IH}$	High-level input voltage		$0.7 V_{DD}$		$V_{DD}$	V
$V_{IL}$	Low-level input voltage				$0.3 V_{DD}$	V
$t_{DS}$	Data set up time prior to PCLK transition	$f(\text{PCLK}) = 30\text{ MHz}$ ; see <a href="#">Figure 7</a>	2			ns
$t_{DH}$	Data hold time after PCLK transition		2			ns

(1) Unused single-ended inputs must be held high or low to prevent them from floating.

(2) PCLK input frequencies lower than 500 kHz force the SN65LVDS303 into standby mode. Input frequencies between 500 kHz and 3 MHz may or may not activate the SN65LVDS303. Input frequencies beyond 3 MHz activate the SN65LVDS303.

(3) Period jitter is the deviation in cycle time of a signal with respect to the ideal period over a random sample of 100,000 cycles.

(4) Cycle-to-cycle jitter is the variation in cycle time of a signal between adjacent cycles; over a random sample of 1,000 adjacent cycle pairs.

**DEVICE ELECTRICAL CHARACTERISTICS**

over recommended operating conditions (unless otherwise noted)

PARAMETER	TEST CONDITIONS		MIN	TYP <sup>(1)</sup>	MAX	UNIT	
$I_{DD}$	1ChM	$V_{DD} = V_{DDPLL} = V_{DDPLL} = V_{DDLVD}$ , $R_{L(PCLK)} = R_{L(DX)} = 100 \Omega$ , $V_{IH} = V_{DD}$ , $V_{IL} = 0 V$ , TXEN at $V_{DD}$ , alternating 1010 serial bit pattern	$f_{PCLK} = 4 \text{ MHz}$		9	11.4	mA
			$f_{PCLK} = 6 \text{ MHz}$		10.6	12.6	
			$f_{PCLK} = 15 \text{ MHz}$		16	18.8	
	1ChM	$V_{DD} = V_{DDPLL} = V_{DDPLL} = V_{DDLVD}$ , $R_{L(PCLK)} = R_{L(DX)} = 100 \Omega$ , $V_{IH} = V_{DD}$ , $V_{IL} = 0 V$ , TXEN at $V_{DD}$ , typical power test pattern (see Table 7)	$f_{PCLK} = 4 \text{ MHz}$		8		mA
			$f_{PCLK} = 6 \text{ MHz}$		8.9		
			$f_{PCLK} = 15 \text{ MHz}$		14		
	2ChM	$V_{DD} = V_{DDPLL} = V_{DDPLL} = V_{DDLVD}$ , $R_{L(PCLK)} = R_{L(DX)} = 100 \Omega$ , $V_{IH} = V_{DD}$ , $V_{IL} = 0 V$ , TXEN at $V_{DD}$ , alternating 1010 serial bit pattern	$f_{PCLK} = 8 \text{ MHz}$		13.7	15.9	mA
			$f_{PCLK} = 22 \text{ MHz}$		18.4	22	
			$f_{PCLK} = 30 \text{ MHz}$		21.4	25.8	
	2ChM	$V_{DD} = V_{DDPLL} = V_{DDPLL} = V_{DDLVD}$ , $R_{L(PCLK)} = R_{L(DX)} = 100 \Omega$ , $V_{IH} = V_{DD}$ , $V_{IL} = 0 V$ , TXEN at $V_{DD}$ , typical power test pattern (see Table 8)	$f_{PCLK} = 8 \text{ MHz}$		11.5		mA
$f_{PCLK} = 22 \text{ MHz}$				16			
$f_{PCLK} = 30 \text{ MHz}$				19.1			
	Standby mode	$V_{DD} = V_{DDPLL} = V_{DDPLL} = V_{DDLVD}$ $= V_{DDLVD}$ , $R_{L(PCLK)} =$ $R_{L(DX)} = 100 \Omega$ , $V_{IH} =$ $V_{DD}$ , $V_{IL} = 0 V$ , all inputs held static high or static low		0.61	10	$\mu A$	
	Shutdown mode			0.55	10	$\mu A$	

(1) All typical values are at 25°C and with 1.8 V supply unless otherwise noted.

**OUTPUT ELECTRICAL CHARACTERISTICS**

over operating free-air temperature range (unless otherwise noted)

PARAMETER	TEST CONDITIONS	MIN	TYP <sup>(1)</sup>	MAX	UNIT
<b>SubLVDS Output (D0+, D0-, D1+, D1-, CLK+, and CLK-)</b>					
$V_{OC(SS)M}$ Steady-state common-mode output voltage	Output load see Figure 9	0.8	0.9	1.0	V
$V_{OCM(SS)}$ Change in steady-state common-mode output voltage		-10		10	mV
$V_{OCM(PP)}$ Peak-to-peak common mode output voltage				75	mV
$ V_{Odl} $ Differential output voltage magnitude $ V_{Dx+} - V_{Dx-} $ , $ V_{CLK+} - V_{CLK-} $		100	150	200	mV
$\Delta V_{Odl} $ Change in differential output voltage between logic states		-10		10	mV
$Z_{OD(CLK)}$ Differential small-signal output impedance	TXEN at $V_{DD}$		210		$\Omega$
$I_{OSD}$ Differential short-circuit output current	$V_{OD} = 0 V$ , $f_{PCLK} = 28 \text{ MHz}$			10	mA
$I_{OS}$ Short circuit output current <sup>(2)</sup>	$V_O = 0 V$ or $V_{DD}$		5		
$I_{OZ}$ High-impedance state output current	$V_O = 0 V$ or $V_{DD}(\text{max})$ , TXEN at GND	-3		3	$\mu A$

(1) All typical values are at 25°C and with 1.8-V supply, unless otherwise noted.

(2) All SN65LVDS303 outputs tolerate shorts to GND or  $V_{DD}$  without device damage.**INPUT ELECTRICAL CHARACTERISTICS**

over operating free-air temperature range (unless otherwise noted)

PARAMETER	TEST CONDITIONS	MIN	TYP <sup>(1)</sup>	MAX	UNIT
<b>PCLK, R[0:7], G[0:7], B[0:7], VS, HS, DE, PCLK, LS, CPOL, TXEN, SWAP</b>					
$I_{IH}$ High-level input current	$V_{IN} = 0.7 \times V_{DD}$	-200		200	nA
$I_{IL}$ Low-level input current	$V_{IN} = 0.3 \times V_{DD}$	-200		200	
$C_{IN}$ Input capacitance			1.5		pF

(1) All typical values are at 25°C and with 1.8-V supply, unless otherwise noted.

## SWITCHING CHARACTERISTICS

over recommended operating conditions (unless otherwise noted)

PARAMETER	TEST CONDITIONS	MIN	TYP <sup>(1)</sup>	MAX	UNIT	
$t_r$	20%-to-80% differential output signal rise time	See Figure 8 and Figure 9	250	500	ps	
$t_f$	20%-to-80% differential output signal fall time	See Figure 8 and Figure 9	250	500		
$f_{BW}$	PLL bandwidth (3dB cutoff frequency)	Tested from PCLK input to CLK output, See Figure 6 <sup>(2)</sup>	$f_{PCLK} = 22 \text{ MHz}$ $f_{PCLK} = 30 \text{ MHz}$	$0.082 f_{PCLK}$ $0.078 f_{PCLK}$	MHz	
$t_{pd(L)}$	Propagation delay time, input to serial output (data latency Figure 10)	TXEN at $V_{DD}$ , $V_{IH}=V_{DD}$ , $V_{IL}=GND$ , $R_L=100 \Omega$	1-channel mode 2-channel mode	$1/f_{PCLK}$ $1.21/f_{PCLK}$	$1.2/f_{PCLK}$ $1.5/f_{PCLK}$	s
$t_H \times f_{CLK0}$	Output CLK duty cycle		1-channel mode 2-channel mode	0.45 0.53	0.50 0.55 0.58	
$t_{GS}$	TXEN Glitch suppression pulse duration <sup>(3)</sup>	$V_{IH} = V_{DD}$ , $V_{IL} = GND$ , TXEN toggles between $V_{IL}$ and $V_{IH}$ , see Figure 13 and Figure 14.	3.8		10	$\mu\text{s}$
$t_{pwrup}$	Enable time from power down ( $\uparrow$ TXEN)	Time from TXEN pulled high to CLK and Dx outputs enabled and transmit valid data; see Figure 14		0.24	2	ms
$t_{pwrdn}$	Disable time from active mode ( $\downarrow$ TXEN)	TXEN is pulled low during transmit mode; time measurement until output is disabled and PLL is Shutdown; see Figure 14		0.5	11	$\mu\text{s}$
$t_{wakeup}$	Enable time from standby ( $\uparrow$ PCLK)	TXEN at $V_{DD}$ ; device in standby; time measurement from PCLK starts switching to CLK and Dx outputs enabled and transmit valid data; see Figure 14		0.23	2	ms
$t_{sleep}$	Disable time from active mode (PCLK stopping)	TXEN at $V_{DD}$ ; device is transmitting; time measurement from PCLK input signal stops until CLK + Dx outputs are disabled and PLL is disabled; see Figure 14		0.4	100	$\mu\text{s}$

- (1) All typical values are at 25°C and with 1.8-V supply unless otherwise noted.
- (2) The Maximum Limit is based on statistical analysis of the device performance over process, voltage, and temp ranges. This parameter is functionality tested only on Automatic Test Equipment (ATE).
- (3) The TXEN input incorporates glitch-suppression circuitry to disregard short input pulses.  $t_{GS}$  is the duration of either a high-to-low or low-to-high transition that is suppressed.

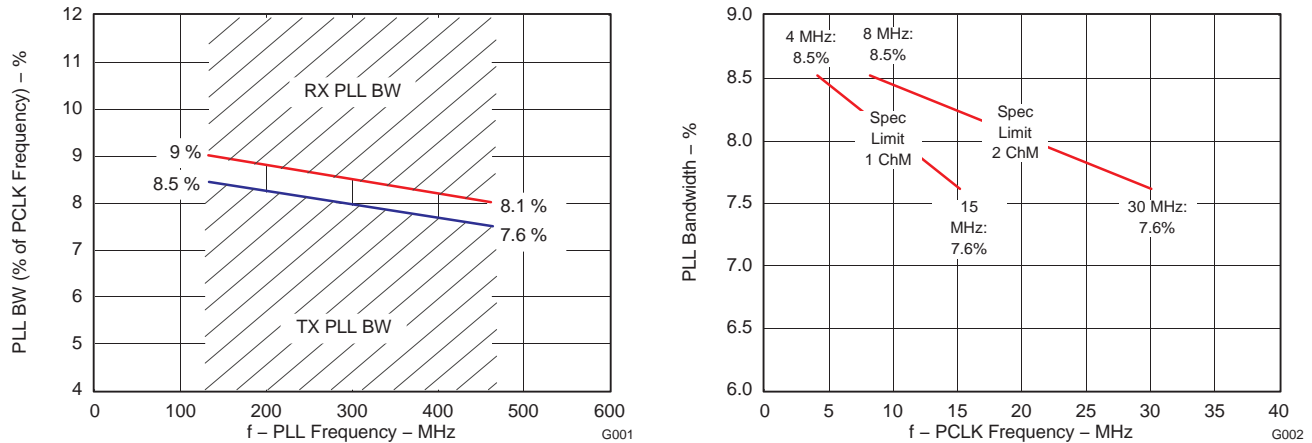


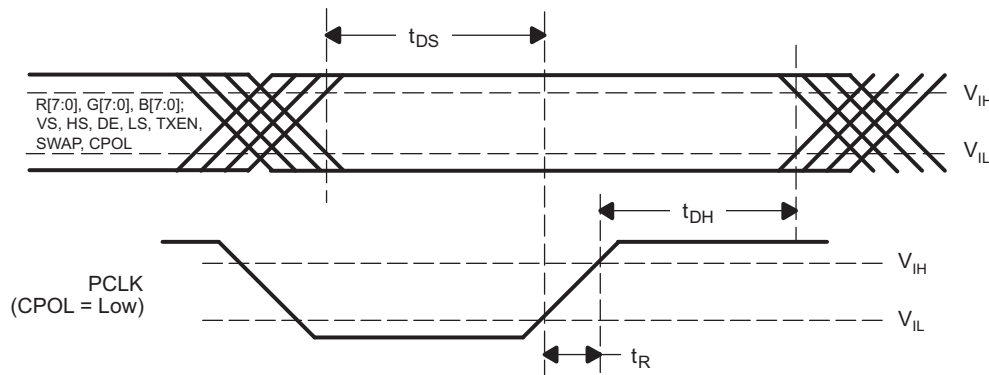
Figure 6. SN65LVDS303 PLL Bandwidth (Also Showing the SN65LVDS304 PLL Bandwidth)

**TIMING CHARACTERISTICS**

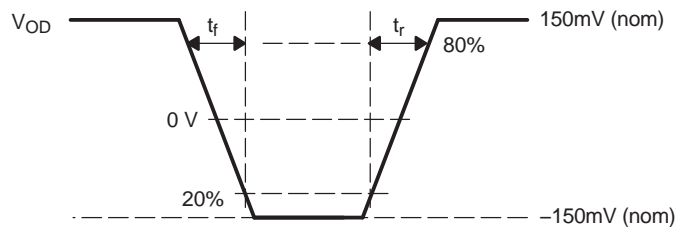
PARAMETER	TEST CONDITIONS	MIN	TYP	MAX	UNIT
t <sub>PPOSX</sub> Output pulse position, serial data to ↑CLK; see (1)(2) and Figure 12	1ChM: x = 0..29, f <sub>PCLK</sub> = 15 MHz; TXEN at V <sub>DD</sub> , V <sub>IH</sub> = V <sub>DD</sub> , V <sub>IL</sub> = GND, R <sub>L</sub> = 100 Ω, test pattern as in Table 11 <sup>(3)</sup>	$\frac{x}{30 \cdot f_{PCLK}} - 330 \text{ ps}$		$\frac{x}{30 \cdot f_{PCLK}} + 330 \text{ ps}$	ps
	1ChM: x = 0..29, f <sub>PCLK</sub> = 4 MHz to 15 MHz <sup>(4)</sup>	$\frac{x - 0.1845}{30 \cdot f_{PCLK}}$		$\frac{x + 0.1845}{30 \cdot f_{PCLK}}$	
	2ChM: x = 0..14, f <sub>PCLK</sub> = 30 MHz TXEN at V <sub>DD</sub> , V <sub>IH</sub> = V <sub>DD</sub> , V <sub>IL</sub> = GND, R <sub>L</sub> = 100 Ω, test pattern as in Table 12 <sup>(3)</sup>	$\frac{x}{15 \cdot f_{PCLK}} - 330 \text{ ps}$		$\frac{x}{15 \cdot f_{PCLK}} + 330 \text{ ps}$	
	2ChM: x = 0..14, f <sub>PCLK</sub> = 8 MHz to 30 MHz <sup>(4)</sup>	$\frac{x - 0.1845}{15 \cdot f_{PCLK}}$		$\frac{x + 0.1845}{15 \cdot f_{PCLK}}$	

- (1) This number also includes the high-frequency random and deterministic PLL clock jitter that is not traceable by the SN65LVDS304 receiver PLL; t<sub>PPosx</sub> represents the total timing uncertainty of the transmitter necessary to calculate the jitter budget when combined with the SN65LVDS304 receiver.
- (2) The pulse position min/max variation is given with a bit error rate target of 10<sup>-12</sup>; the measurement estimates the random jitter contribution to the total jitter by multiplying the random RMS jitter by the factor 14; measurements of the total jitter are taken with > 10<sup>-12</sup> samples.
- (3) The minimum and maximum limits are based on statistical analysis of the device performance over process, voltage, and temp ranges. This parameter is functionality tested only on automatic test equipment (ATE).
- (4) These minimum and maximum limits are simulated only.

**PARAMETER MEASUREMENT INFORMATION**

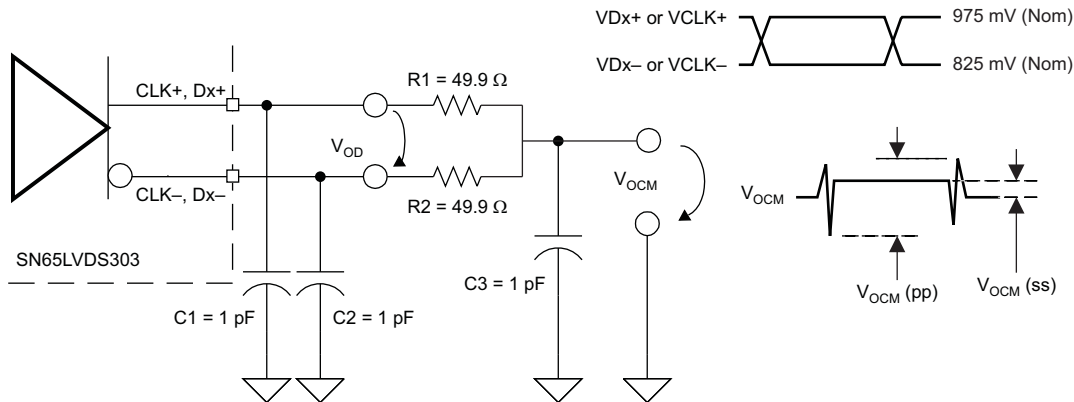


**Figure 7. Setup/Hold Time**



**Figure 8. Rise and Fall Time Definitions**

PARAMETER MEASUREMENT INFORMATION (continued)



NOTES:

- A. 20-MHz output test pattern on all differential outputs (CLK, D0, and D1):  
this is achieved by:
  1. Device is set to 2-channel mode.
  2.  $f_{PCLK} = 20$  MHz
  3. Inputs R[7:3] = B[7:3] connected to  $V_{DD}$ , all other data inputs set to GND.
- B. C1, C2, and C3 include instrumentation and fixture capacitance, tolerance  $\pm 20\%$ ; C, R1, and R2 tolerance  $\pm 1\%$
- C. The measurement of  $V_{OCM(pp)}$  and  $V_{OC(ss)}$  are taken with test equipment bandwidth  $> 1$  GHz.

Figure 9. Driver Output Voltage Test Circuit and Definitions

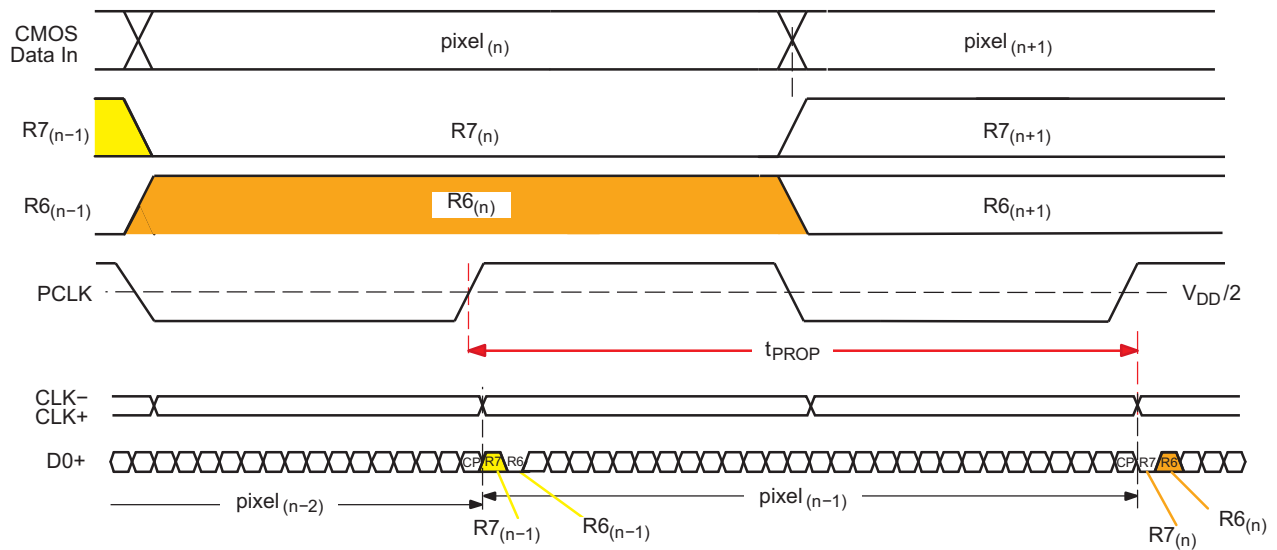
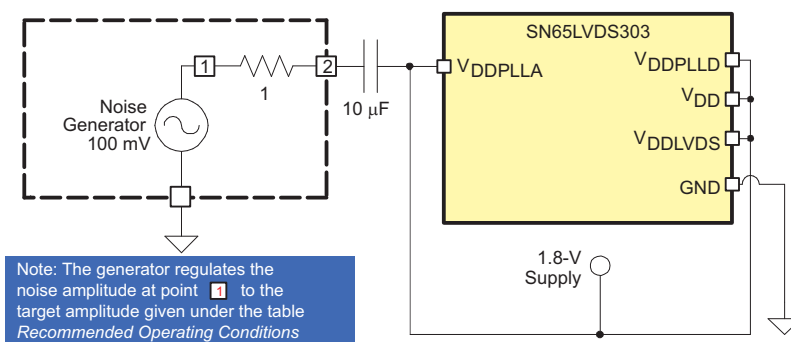


Figure 10.  $t_{pd(L)}$  Propagation Delay Input to Output (LS = 0; CPOL = 0)



Note: The generator regulates the noise amplitude at point 1 to the target amplitude given under the table Recommended Operating Conditions

Figure 11. Power Supply Noise Test Setup

PARAMETER MEASUREMENT INFORMATION (continued)

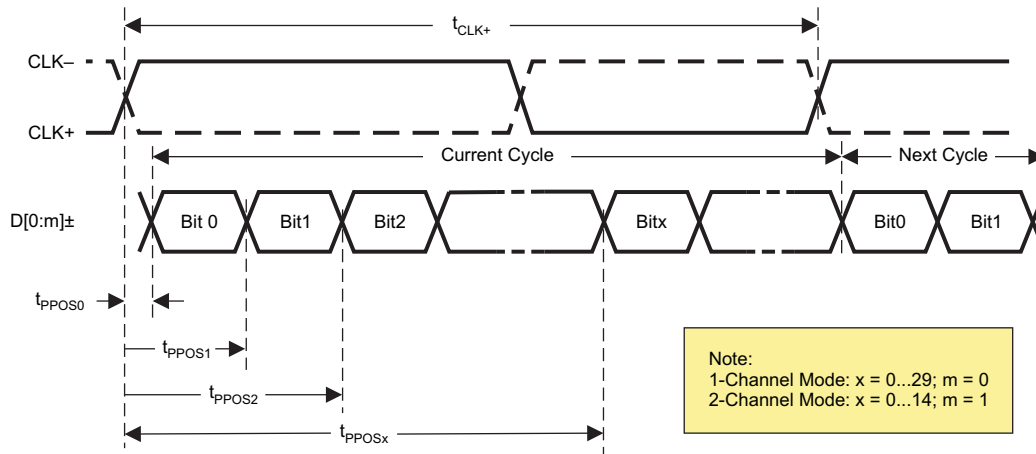


Figure 12.  $t_{SK(0)}$  SubLVDS Output Pulse Position Measurement

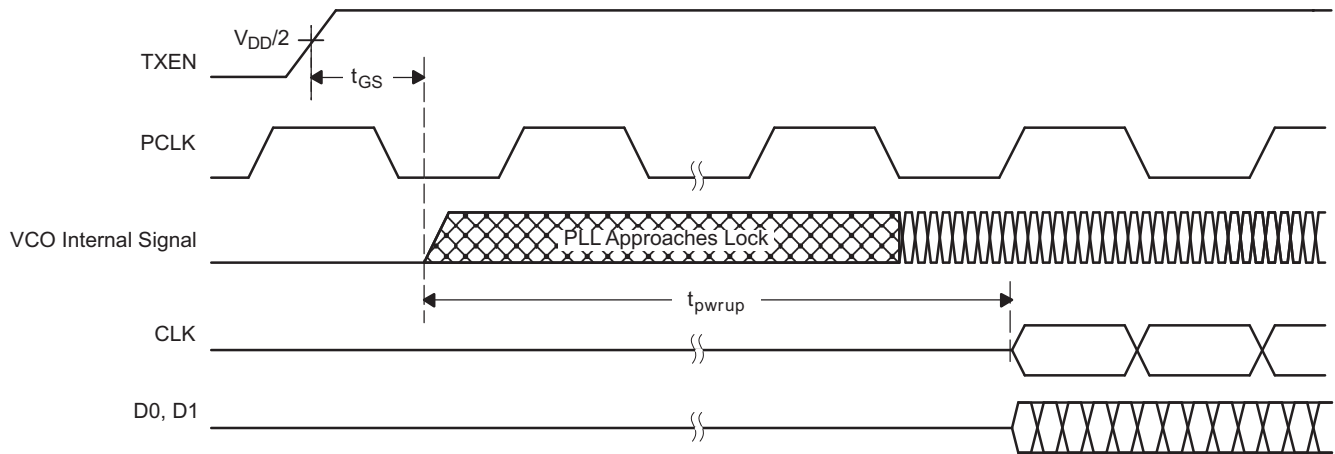


Figure 13. Transmitter Behavior While Approaching Sync



PARAMETER MEASUREMENT INFORMATION (continued)

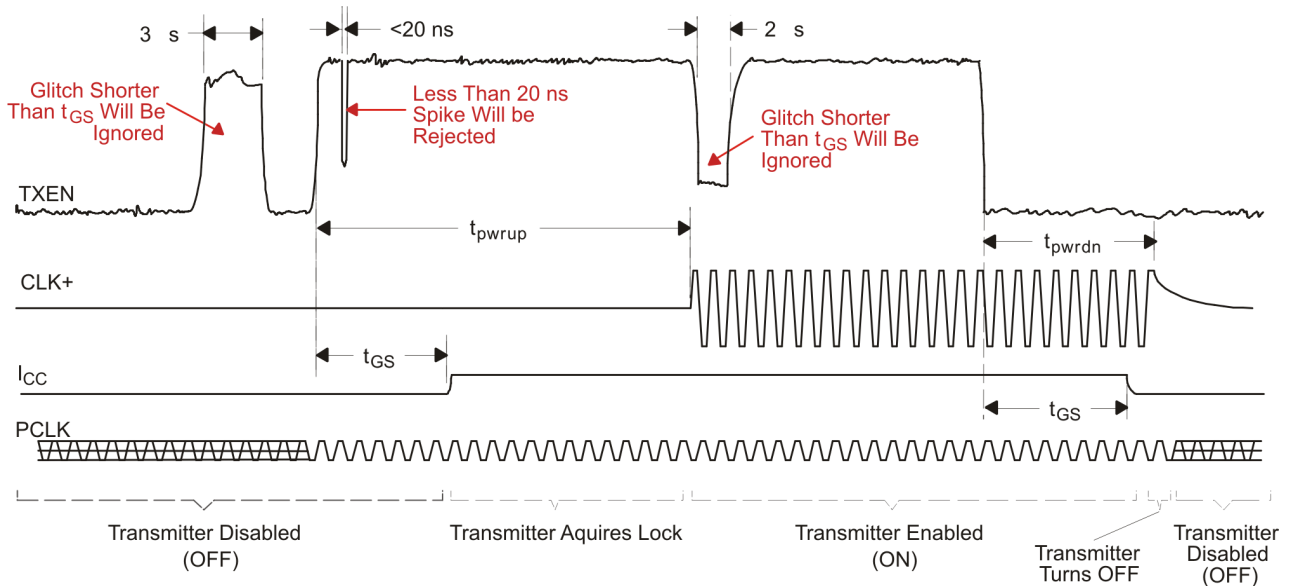


Figure 14. Transmitter Enable Glitch Suppression Time

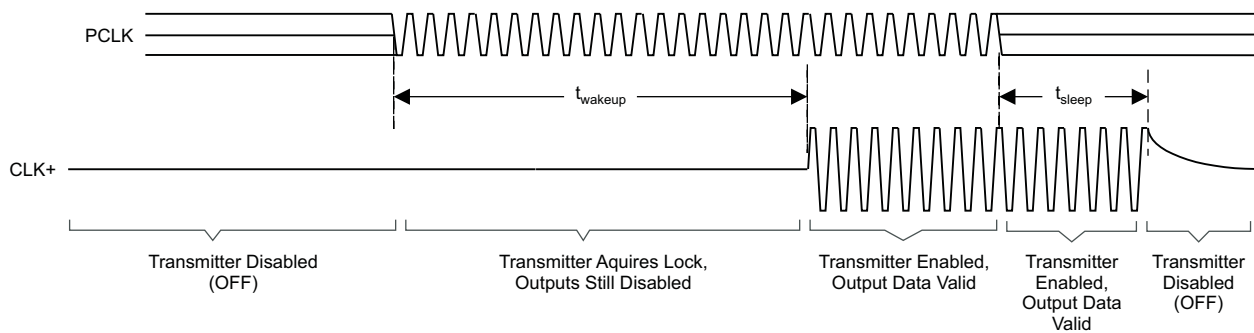


Figure 15. Standby Detection

Power Consumption Tests

Table 6 shows an example test pattern word.

Table 6. Example Test Pattern Word

Word	R[7:4], R[3:0], G[7:4], G[3:0], B[7:4], B[3:0], 0, VS, HS, DE
1	0x7C3E1E7

7				C				3				E				1				E				7			
R7	R6	R5	R4	R3	R2	R1	R0	G7	G6	G5	G4	G3	G2	G1	G0	B7	B6	B5	B4	B3	B2	B1	B0	0	VS	HS	DE
0	1	1	1	1	1	0	0	0	0	1	1	1	1	1	0	0	0	0	1	1	1	1	0	0	1	1	1

Typical IC Power-Consumption Test Pattern

The typical power-consumption test patterns consists of 16 30-bit transmit words in 1-channel mode, eight 30-bit transmit words in 2-channel mode. The pattern repeats itself throughout the entire measurement. It is assumed that every possible transmit code on RGB inputs has the same probability to occur during typical device operation.

**Table 7. Typical IC Power-Consumption Test Pattern, 1-Channel Mode**

Word	Test Pattern: R[7:4], R[3:0], G[7:4], G[3:0], B[7:4], B[3:0], 0, VS, HS, DE
1	0x0000007
2	0xFFFF007
3	0x01FFF47
4	0xF0E07F7
5	0x7C3E1E7
6	0xE707C37
7	0xE1CE6C7
8	0xF1B9237
9	0x91BB347
10	0xD4CCC67
11	0xAD53377
12	0xACB2207
13	0xAAB2697
14	0x5556957
15	0xAAAAAB3
16	0xAAAAAA5

**Table 8. Typical IC Power Consumption Test Pattern, 2-Channel Mode**

Word	Test Pattern: R[7:4], R[3:0], G[7:4], G[3:0], B[7:4], B[3:0], 0, VS, HS, DE
1	0x0000001
2	0x03F03F1
3	0xBFFBFF1
4	0x1D71D71
5	0x4C74C71
6	0xC45C451
7	0xA3AA3A5
8	0x5555553

**Maximum Power Consumption Test Pattern**

The maximum (or worst-case) power consumption of the SN65LVDS303 is tested using the two different test pattern shown in table. test patterns consists of sixteen 30-bit transmit words in 1-channel mode, eight 30-bit transmit words in 2-channel mode. The pattern repeats itself throughout the entire measurement. It is assumed that every possible transmit code on RGB inputs has the same probability to occur during typical device operation.

**Table 9. Worst-Case Power Consumption Test Pattern**

Word	Test Pattern: R[7:4], R[3:0], G[7:4], G[3:0], B[7:4], B[3:0], 0, VS, HS, DE
1	0xAAAAAA5
2	0x5555555

**Table 10. Worst-Case Power Consumption Test Pattern**

Word	Test Pattern: R[7:4], R[3:0], G[7:4], G[3:0], B[7:4], B[3:0], 0, VS, HS, DE
1	0x0000000
2	0xFFFFFFFF7

### Output Skew Pulse Position and Jitter Performance

The following test patterns are used to measure the output skew pulse position and the jitter performance of the SN65LVDS303. The jitter test patterns stress the interconnect for worst-case ISI. Each pattern is self-repeating for the duration of the test.

**Table 11. Transmit Jitter Test Pattern, 1-Channel Mode**

Word	Test Pattern: R[7:4], R[3:0], G[7:4], G[3:0], B[7:4], B[3:0], 0, VS, HS, DE
1	0x0000001
2	0x0000031
3	0x00000F1
4	0x00003F1
5	0x0000FF1
6	0x0003FF1
7	0x000FFF1
8	0x0F0F0F1
9	0x0C30C31
10	0x0842111
11	0x1C71C71
12	0x18C6311
13	0x1111111
14	0x3333331
15	0x2452413
16	0x22A2A25
17	0x5555553
18	0xDB6DB65
19	0xCCCCC1
20	0xEEEEE1
21	0xE739CE1
22	0xE38E381
23	0xF7BDEE1
24	0xF3CF3C1
25	0xF0F0F01
26	0xFFF0001
27	0xFFFC001
28	0xFFFF001
29	0xFFFFC01
30	0xFFFFF01
31	0xFFFFFC1
32	0xFFFFF1

**Table 12. Transmit Jitter Test Pattern, 2-Channel Mode**

Word	Test Pattern: R[7:4], R[3:0], G[7:4], G[3:0], B[7:4], B[3:0], 0, VS, HS, DE
1	0x0000001
2	0x000FFF3
3	0x8008001
4	0x0030037
5	0xE00E001
6	0x00FF001
7	0x007E001
8	0x003C001
9	0x0018001
10	0x1C7E381
11	0x3333331
12	0x555AAA5
13	0x6DBDB61
14	0x7777771
15	0x555AAA3
16	0xAAAAAA5
17	0x5555553
18	0xAAA5555
19	0x8888881
20	0x9242491
21	0xAAA5571
22	0xCCCCCC1
23	0xE3E1C71
24	0xFFE7FF1
25	0xFFC3FF1
26	0xFF81FF1
27	0xFE00FF1
28	0x1FF1FF1
29	0xFFCFFC3
30	0x7FF7FF1
31	0xFFF0007
32	0xFFFFFFFF1

TYPICAL CHARACTERISTICS

POWERDOWN, STANDBY SUPPLY CURRENT vs TEMPERATURE

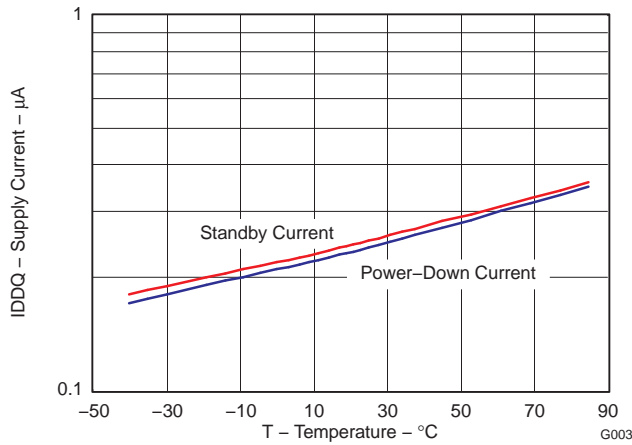


Figure 16.

SUPPLY CURRENT I<sub>DD</sub> vs TEMPERATURE

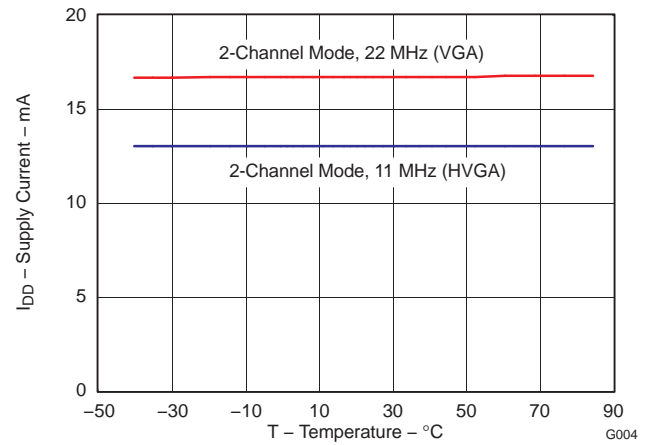


Figure 17.

SUPPLY CURRENT vs PCLK FREQUENCY

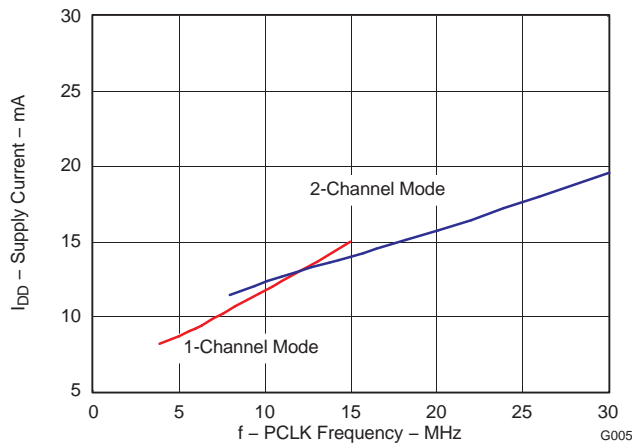


Figure 18.

DIFFERENTIAL OUTPUT SWING vs PCLK FREQUENCY

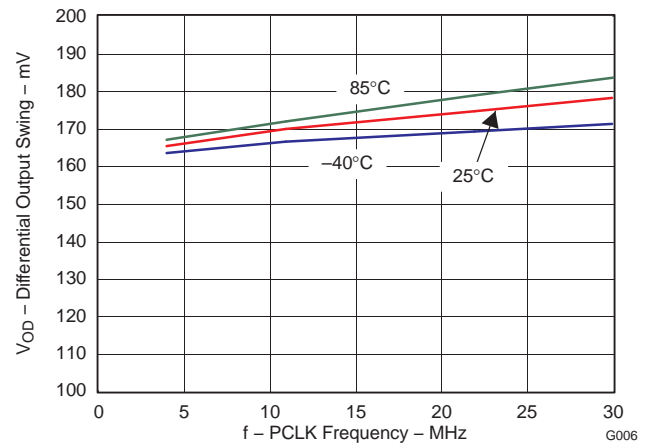


Figure 19.

PLL BANDWIDTH

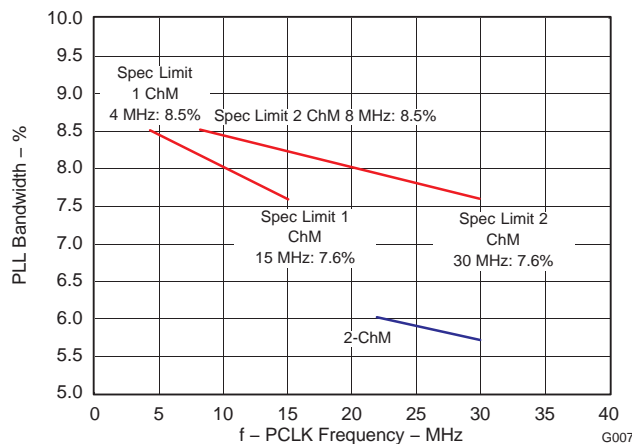


Figure 20.

CYCLE-TO-CYCLE OUTPUT JITTER vs PCLK FREQUENCY

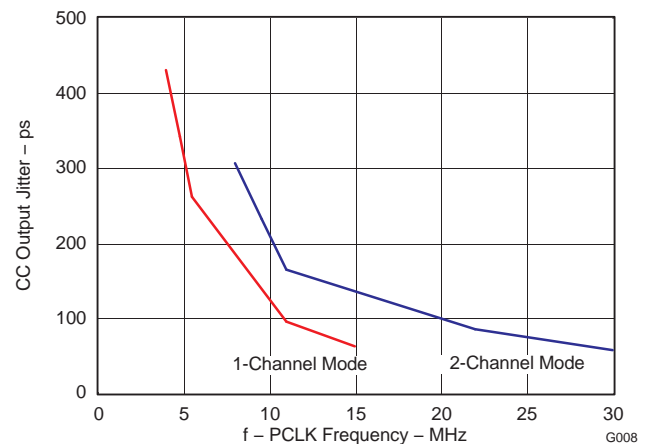


Figure 21.

TYPICAL CHARACTERISTICS (continued)

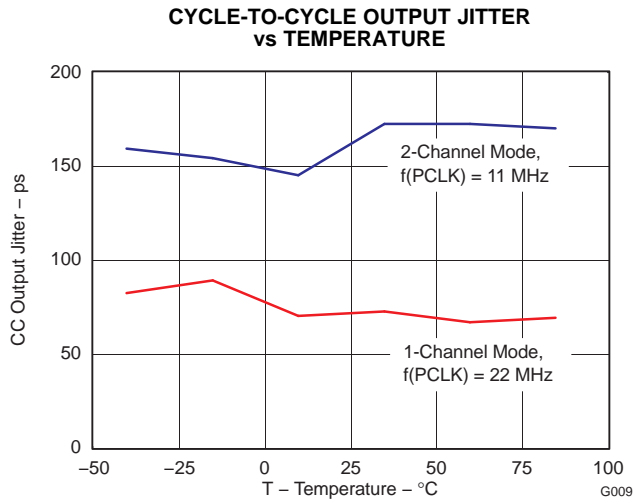


Figure 22.

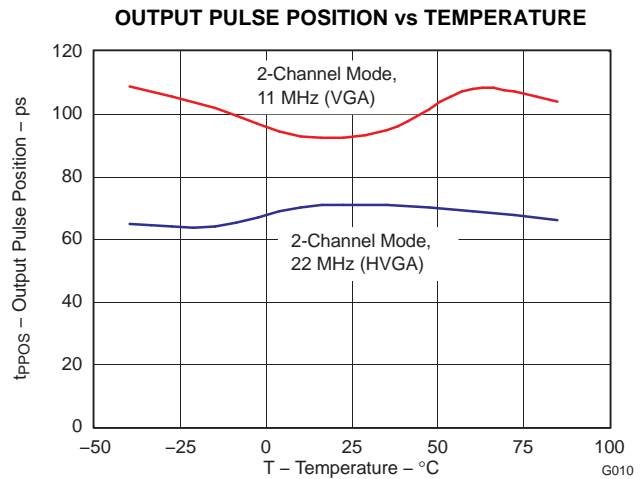


Figure 23.

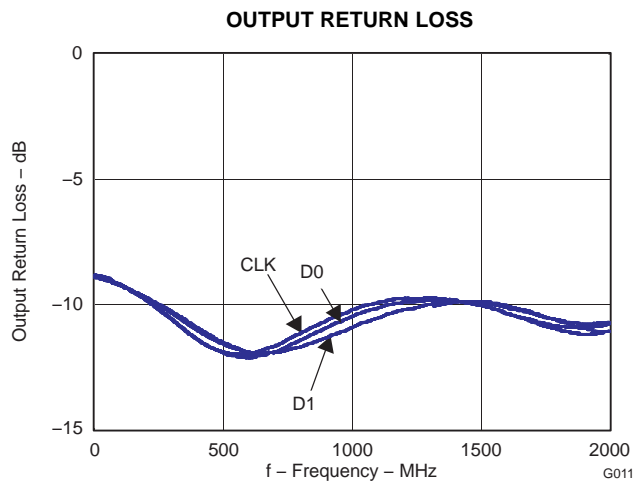


Figure 24.

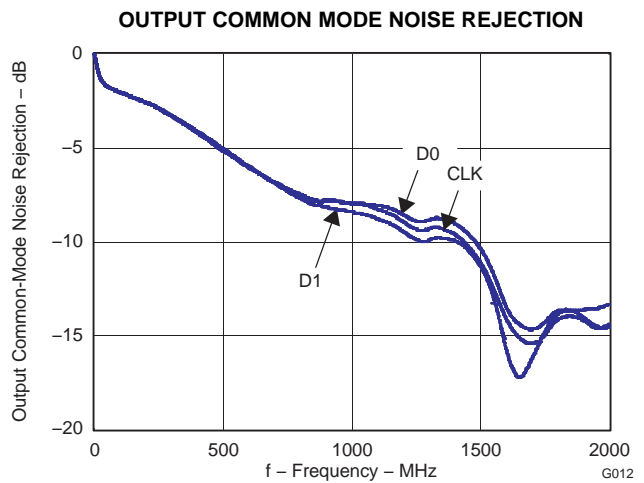


Figure 25.

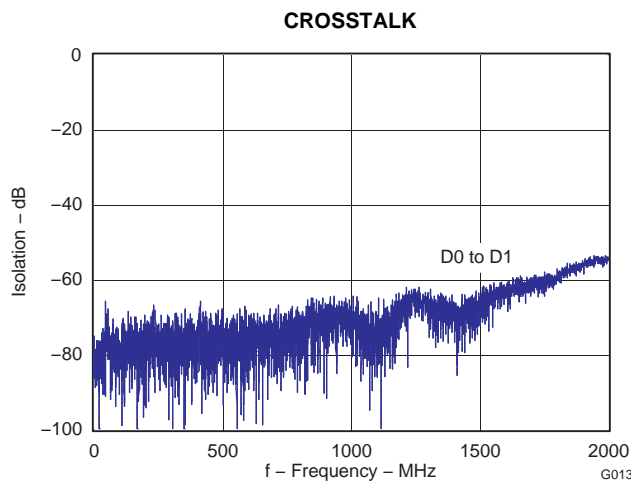


Figure 26.

## APPLICATION INFORMATION

### Preventing Increased Leakage Currents in Control Inputs

A floating (left open) CMOS input allows leakage currents to flow from  $V_{DD}$  to GND. Do not leave any CMOS input unconnected or floating. Every input must be connected to a valid logic level,  $V_{IH}$  or  $V_{IL}$ , while power is supplied to  $V_{DD}$ . This also minimizes the power consumption of standby and power-down modes.

### Power Supply Design Recommendation

For a multilayer PCB, it is recommended to keep one common GND layer underneath the device and connect all ground terminals directly to this plane.

### Decoupling Recommendation

The SN65LVDS303 was designed to operate reliably in a constricted environment with other digital switching ICs. In cell phone designs, the SN65LVDS303 often shares a power supply with the application processor. The SN65LVDS303 can operate with power supply noise as specified in *Recommend Device Operating Conditions*. To minimize the power-supply noise floor, provide good decoupling near the SN65LVDS303 power terminals. The use of four ceramic capacitors ( $2 \times 0.01 \mu\text{F}$  and  $2 \times 0.1 \mu\text{F}$ ) provides good performance. At the very least, it is recommended to install one  $0.1 \mu\text{F}$  and one  $0.01 \mu\text{F}$  capacitor near the SN65LVDS303. To avoid large current loops and trace inductance, the trace length between decoupling capacitor and IC power inputs terminals must be minimized. Placing the capacitor underneath the SN65LVDS303 on the bottom of the PCB is often a good choice.

### VGA Application

Figure 27 shows a possible implementation of a VGA display. The SN65LVDS303 interfaces to the SN65LVDS304, which is the corresponding receiver device to deserialize the data and drive the display driver. The pixel clock rate of 22 MHz assumes  $\sim 10\%$  blanking overhead and 60-Hz display refresh rate. The application assumes 24-bit color resolution. It is also shown how the application processor provides a power-down (reset) signal for both serializer and the display driver. The signal count over the FPC could be further decreased by using the standby option on the SN65LVDS304 and pulling RXEN high with a 30-k $\Omega$  resistor to  $V_{DD}$ .

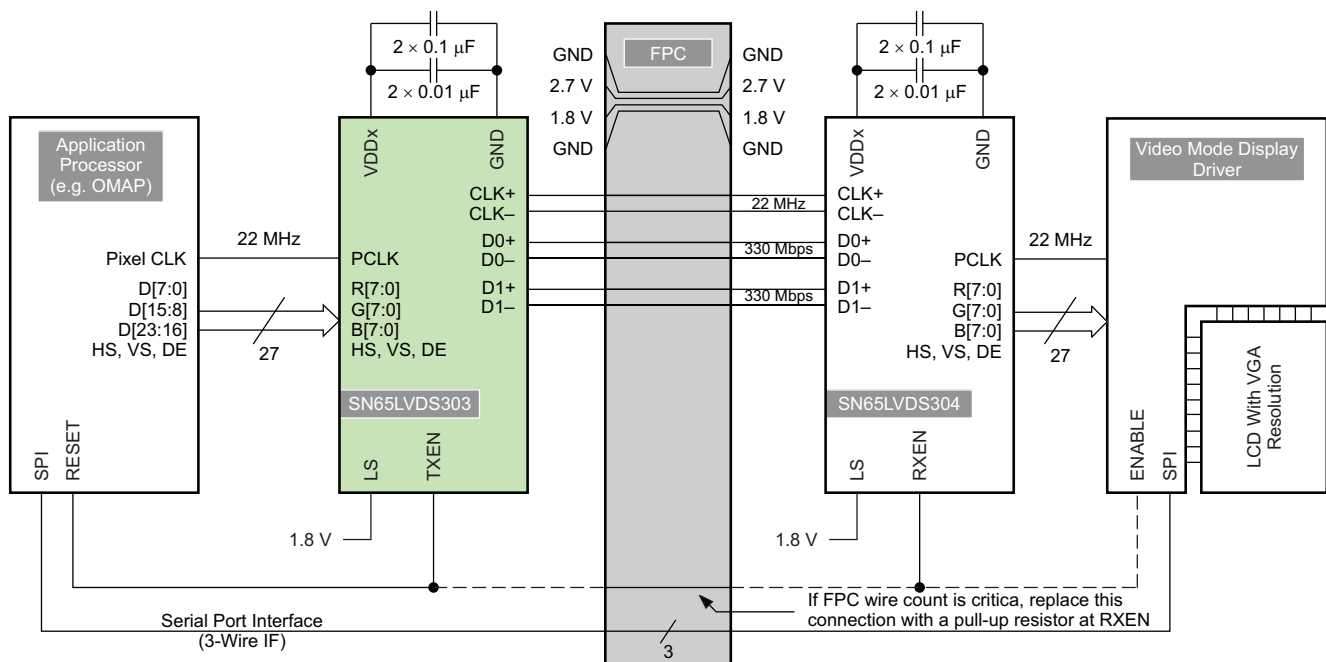


Figure 27. Typical VGA Display Application

## APPLICATION INFORMATION (continued)

### Typical Application Frequencies

The SN65LVDS303 supports pixel clock frequencies from 4 MHz to 30 MHz over one or two data pairs. [Table 13](#) provides a few typical display resolution examples and shows the number of data pairs necessary to connect the LVDS303 with the display. The blanking overhead is assumed to be 20%. Often, blanking overhead is smaller, resulting in a lower data rate. Furthermore, the examples in the table assume a display frame refresh rate of 60-Hz or 90-Hz. The actual refresh rate may differ depending on the application-processor clock implementation.

**Table 13. Typical Application Data Rates and Serial Pair Usage**

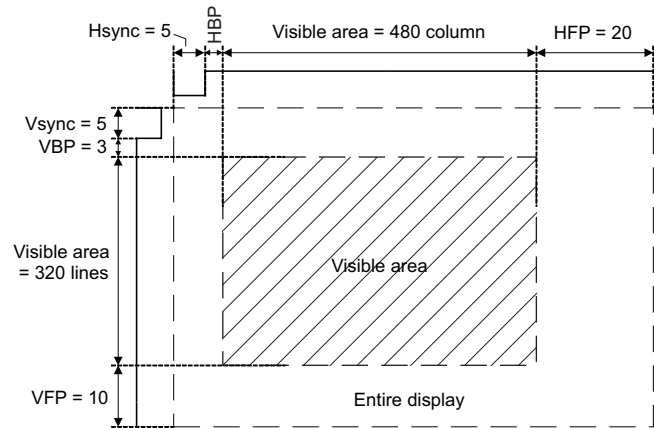
Display Screen Resolution	Visible Pixel Count	Blanking Overhead	Display Refresh Rate	Pixel Clock Frequency [MHz]	Serial Data Rate Per Pair	
					1-ChM	2-ChM
176 × 220 (QCIF+)	38,720	20%	90 Hz	4.2 MHz	125 Mbps	
240 × 320 (QVGA)	76,800		60 Hz	5.5 MHz	166 Mbps	
640 × 200	128,000			9.2 MHz	276 Mbps	138 Mbps
352 × 416 (CIF+)	146,432			10.5 MHz	316 Mbps	158 Mbps
352 × 440	154,880			11.2 MHz	335 Mbps	167 Mbps
320 × 480 (HVGA)	153,600			11.1 MHz	332 Mbps	166 Mbps
800 × 250	200,000			14.4 MHz	432 Mbps	216 Mbps
640 × 320	204,800			14.7 MHz	442 Mbps	221 Mbps
640 × 480 (VGA)	307,200			22.1 MHz		332 Mbps
1024 × 320	327,680			23.6 MHz		354 Mbps
854 × 480 (WVGA)	409,920			29.5 MHz		443 Mbps



**Calculation Example: HVGA Display**

This example calculation shows a typical half-VGA display with these parameters:

Display resolution:	480 × 320
Frame refresh rate:	58.4 Hz
Vertical visible pixels:	320 lines
Vertical front porch:	10 lines
Vertical sync:	5 lines
Vertical back porch:	3 lines
Horizontal visible pixels:	480 columns
Horizontal front porch:	20 columns
Horizontal sync:	5 columns
Horizontal back porch:	3 columns



**Figure 28. HVGA Display Parameters**

Calculation of the total number of pixels and blanking overhead:

Visible area pixel count:	$480 \times 320 = 153,600$ pixels
Total frame pixel count:	$(480 + 20 + 5 + 3) \times (320 + 10 + 5 + 3) = 171,704$ pixels
Blanking overhead:	$(171,704 - 153,600) \div 153,600 \approx 11.8\%$

The application requires following serial-link parameters:

Pixel clock frequency:	$171,704 \times 58.4 \text{ Hz} = 10 \text{ MHz}$
Serial data rate:	1-channel mode: $10 \text{ MHz} \times 30 \text{ bits/channel} = 300 \text{ Mbps}$
	2-channel mode: $10 \text{ MHz} \times 15 \text{ bits/channel} = 150 \text{ Mbps}$

**PACKAGING INFORMATION**

Orderable Device	Status <sup>(1)</sup>	Package Type	Package Drawing	Pins	Package Qty	Eco Plan <sup>(2)</sup>	Lead/Ball Finish	MSL Peak Temp <sup>(3)</sup>
SN65LVDS303ZQER	ACTIVE	BGA MI CROSTA R JUNI OR	ZQE	80	2500	Green (RoHS & no Sb/Br)	SNAGCU	Level-3-260C-168 HR

<sup>(1)</sup> The marketing status values are defined as follows:

**ACTIVE:** Product device recommended for new designs.

**LIFEBUY:** TI has announced that the device will be discontinued, and a lifetime-buy period is in effect.

**NRND:** Not recommended for new designs. Device is in production to support existing customers, but TI does not recommend using this part in a new design.

**PREVIEW:** Device has been announced but is not in production. Samples may or may not be available.

**OBSOLETE:** TI has discontinued the production of the device.

<sup>(2)</sup> Eco Plan - The planned eco-friendly classification: Pb-Free (RoHS), Pb-Free (RoHS Exempt), or Green (RoHS & no Sb/Br) - please check <http://www.ti.com/productcontent> for the latest availability information and additional product content details.

**TBD:** The Pb-Free/Green conversion plan has not been defined.

**Pb-Free (RoHS):** TI's terms "Lead-Free" or "Pb-Free" mean semiconductor products that are compatible with the current RoHS requirements for all 6 substances, including the requirement that lead not exceed 0.1% by weight in homogeneous materials. Where designed to be soldered at high temperatures, TI Pb-Free products are suitable for use in specified lead-free processes.

**Pb-Free (RoHS Exempt):** This component has a RoHS exemption for either 1) lead-based flip-chip solder bumps used between the die and package, or 2) lead-based die adhesive used between the die and leadframe. The component is otherwise considered Pb-Free (RoHS compatible) as defined above.

**Green (RoHS & no Sb/Br):** TI defines "Green" to mean Pb-Free (RoHS compatible), and free of Bromine (Br) and Antimony (Sb) based flame retardants (Br or Sb do not exceed 0.1% by weight in homogeneous material)

<sup>(3)</sup> MSL, Peak Temp. -- The Moisture Sensitivity Level rating according to the JEDEC industry standard classifications, and peak solder temperature.

**Important Information and Disclaimer:**The information provided on this page represents TI's knowledge and belief as of the date that it is provided. TI bases its knowledge and belief on information provided by third parties, and makes no representation or warranty as to the accuracy of such information. Efforts are underway to better integrate information from third parties. TI has taken and continues to take reasonable steps to provide representative and accurate information but may not have conducted destructive testing or chemical analysis on incoming materials and chemicals. TI and TI suppliers consider certain information to be proprietary, and thus CAS numbers and other limited information may not be available for release.

In no event shall TI's liability arising out of such information exceed the total purchase price of the TI part(s) at issue in this document sold by TI to Customer on an annual basis.



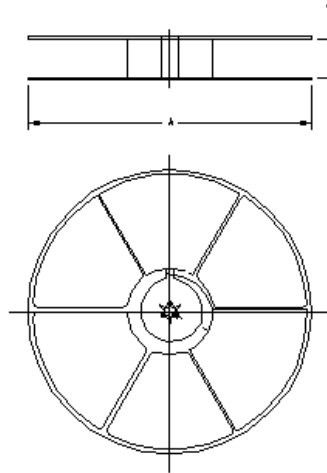
Carrier tape design is defined largely by the component length, width, and thickness.

$A_o$ = Dimension designed to accommodate the component width.
$B_o$ = Dimension designed to accommodate the component length.
$K_o$ = Dimension designed to accommodate the component thickness.
$W$ = Overall width of the carrier tape.
$P$ = Pitch between successive cavity centers.



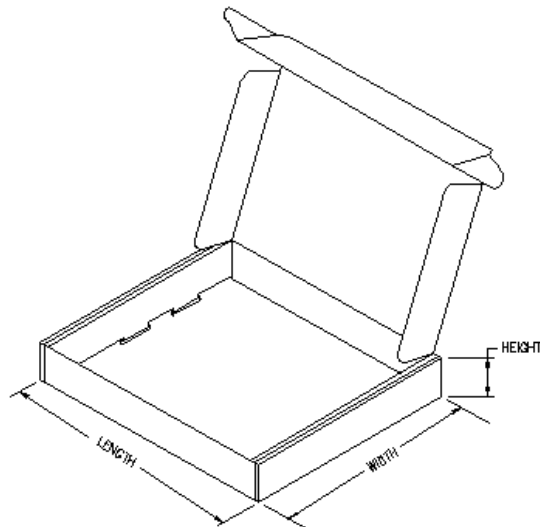
**TAPE AND REEL INFORMATION**

Device	Package	Pins	Site	Reel Diameter (mm)	Reel Width (mm)	A0 (mm)	B0 (mm)	K0 (mm)	P1 (mm)	W (mm)	Pin1 Quadrant
SN65LVDS303ZQER	ZQE	80	TAI	330	12	5.3	5.3	1.5	8	12	NONE



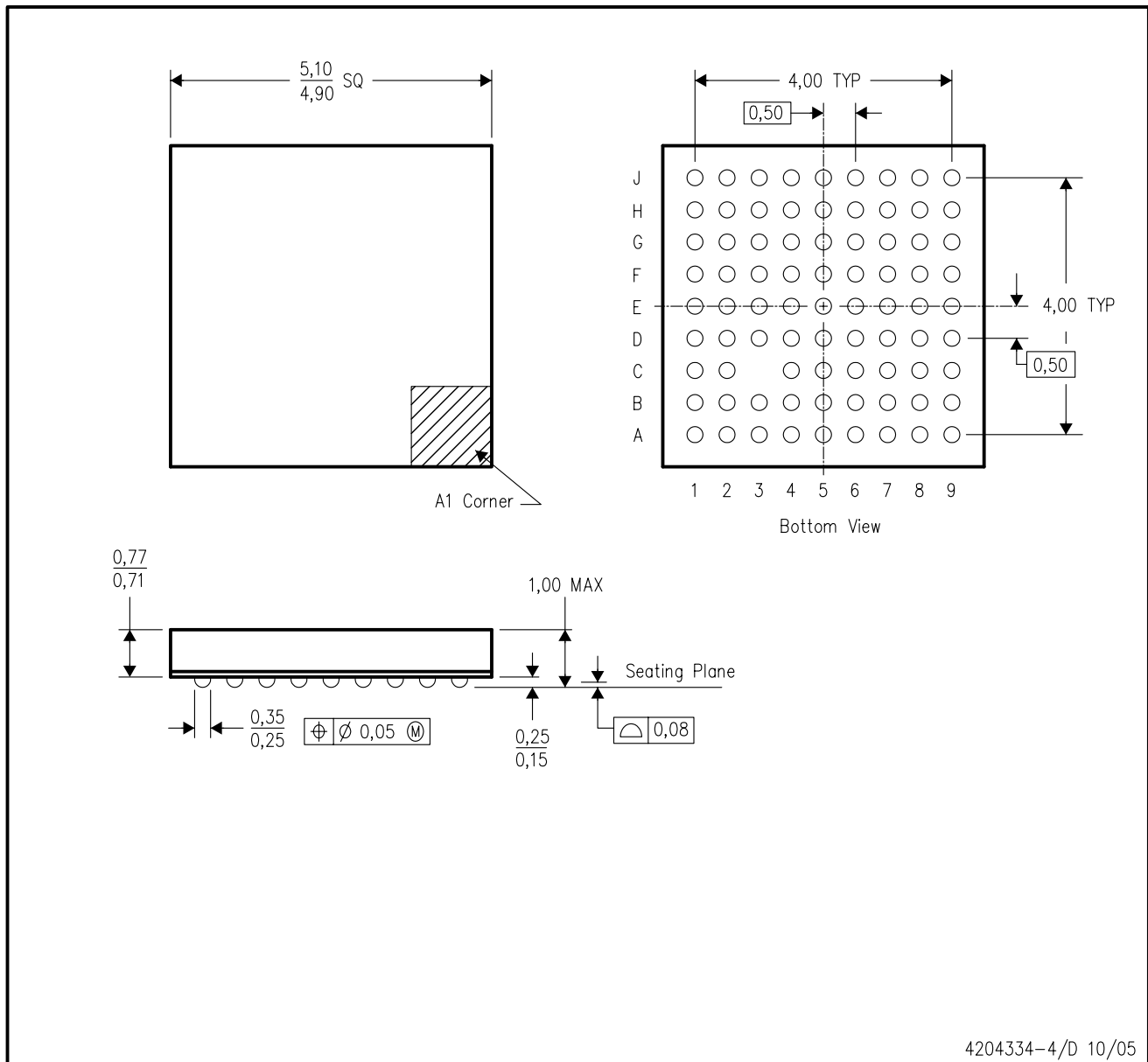
**TAPE AND REEL BOX INFORMATION**

Device	Package	Pins	Site	Length (mm)	Width (mm)	Height (mm)
SN65LVDS303ZQER	ZQE	80	TAI	342.9	336.6	20.64



ZQE (S-PBGA-N80)

PLASTIC BALL GRID ARRAY



- NOTES:
- A. All linear dimensions are in millimeters.
  - B. This drawing is subject to change without notice.
  - C. Falls within JEDEC MO-225
  - D. This is a lead-free solder ball design.

## IMPORTANT NOTICE

Texas Instruments Incorporated and its subsidiaries (TI) reserve the right to make corrections, modifications, enhancements, improvements, and other changes to its products and services at any time and to discontinue any product or service without notice. Customers should obtain the latest relevant information before placing orders and should verify that such information is current and complete. All products are sold subject to TI's terms and conditions of sale supplied at the time of order acknowledgment.

TI warrants performance of its hardware products to the specifications applicable at the time of sale in accordance with TI's standard warranty. Testing and other quality control techniques are used to the extent TI deems necessary to support this warranty. Except where mandated by government requirements, testing of all parameters of each product is not necessarily performed.

TI assumes no liability for applications assistance or customer product design. Customers are responsible for their products and applications using TI components. To minimize the risks associated with customer products and applications, customers should provide adequate design and operating safeguards.

TI does not warrant or represent that any license, either express or implied, is granted under any TI patent right, copyright, mask work right, or other TI intellectual property right relating to any combination, machine, or process in which TI products or services are used. Information published by TI regarding third-party products or services does not constitute a license from TI to use such products or services or a warranty or endorsement thereof. Use of such information may require a license from a third party under the patents or other intellectual property of the third party, or a license from TI under the patents or other intellectual property of TI.

Reproduction of information in TI data books or data sheets is permissible only if reproduction is without alteration and is accompanied by all associated warranties, conditions, limitations, and notices. Reproduction of this information with alteration is an unfair and deceptive business practice. TI is not responsible or liable for such altered documentation.

Resale of TI products or services with statements different from or beyond the parameters stated by TI for that product or service voids all express and any implied warranties for the associated TI product or service and is an unfair and deceptive business practice. TI is not responsible or liable for any such statements.

TI products are not authorized for use in safety-critical applications (such as life support) where a failure of the TI product would reasonably be expected to cause severe personal injury or death, unless officers of the parties have executed an agreement specifically governing such use. Buyers represent that they have all necessary expertise in the safety and regulatory ramifications of their applications, and acknowledge and agree that they are solely responsible for all legal, regulatory and safety-related requirements concerning their products and any use of TI products in such safety-critical applications, notwithstanding any applications-related information or support that may be provided by TI. Further, Buyers must fully indemnify TI and its representatives against any damages arising out of the use of TI products in such safety-critical applications.

TI products are neither designed nor intended for use in military/aerospace applications or environments unless the TI products are specifically designated by TI as military-grade or "enhanced plastic." Only products designated by TI as military-grade meet military specifications. Buyers acknowledge and agree that any such use of TI products which TI has not designated as military-grade is solely at the Buyer's risk, and that they are solely responsible for compliance with all legal and regulatory requirements in connection with such use.

TI products are neither designed nor intended for use in automotive applications or environments unless the specific TI products are designated by TI as compliant with ISO/TS 16949 requirements. Buyers acknowledge and agree that, if they use any non-designated products in automotive applications, TI will not be responsible for any failure to meet such requirements.

Following are URLs where you can obtain information on other Texas Instruments products and application solutions:

### Products

Amplifiers	<a href="http://amplifier.ti.com">amplifier.ti.com</a>
Data Converters	<a href="http://dataconverter.ti.com">dataconverter.ti.com</a>
DSP	<a href="http://dsp.ti.com">dsp.ti.com</a>
Interface	<a href="http://interface.ti.com">interface.ti.com</a>
Logic	<a href="http://logic.ti.com">logic.ti.com</a>
Power Mgmt	<a href="http://power.ti.com">power.ti.com</a>
Microcontrollers	<a href="http://microcontroller.ti.com">microcontroller.ti.com</a>
Low Power Wireless	<a href="http://www.ti.com/lpw">www.ti.com/lpw</a>

### Applications

Audio	<a href="http://www.ti.com/audio">www.ti.com/audio</a>
Automotive	<a href="http://www.ti.com/automotive">www.ti.com/automotive</a>
Broadband	<a href="http://www.ti.com/broadband">www.ti.com/broadband</a>
Digital Control	<a href="http://www.ti.com/digitalcontrol">www.ti.com/digitalcontrol</a>
Military	<a href="http://www.ti.com/military">www.ti.com/military</a>
Optical Networking	<a href="http://www.ti.com/opticalnetwork">www.ti.com/opticalnetwork</a>
Security	<a href="http://www.ti.com/security">www.ti.com/security</a>
Telephony	<a href="http://www.ti.com/telephony">www.ti.com/telephony</a>
Video & Imaging	<a href="http://www.ti.com/video">www.ti.com/video</a>
Wireless	<a href="http://www.ti.com/wireless">www.ti.com/wireless</a>

Mailing Address: Texas Instruments, Post Office Box 655303, Dallas, Texas 75265  
Copyright © 2007, Texas Instruments Incorporated