

High-Speed, Single-Supply, Rail-to-Rail OPERATIONAL AMPLIFIERS

MicroAmplifier™ Series

FEATURES

- RAIL-TO-RAIL INPUT
- RAIL-TO-RAIL OUTPUT (within 10mV)
- WIDE BANDWIDTH: 38MHz
- HIGH SLEW RATE: 22V/μs
- LOW NOISE: 5nV/√Hz
- LOW THD+NOISE: 0.0006%
- UNITY-GAIN STABLE
- MicroSIZE PACKAGES
- SINGLE, DUAL, AND QUAD

APPLICATIONS

- CELL PHONE PA CONTROL LOOPS
- DRIVING A/D CONVERTERS
- VIDEO PROCESSING
- DATA ACQUISITION
- PROCESS CONTROL
- AUDIO PROCESSING
- COMMUNICATIONS
- ACTIVE FILTERS
- TEST EQUIPMENT

DESCRIPTION

The OPA350 series rail-to-rail CMOS operational amplifiers are optimized for low voltage, single-supply operation. Rail-to-rail input/output, low noise (5nV/√Hz), and high speed operation (38MHz, 22V/μs) make them ideal for driving sampling Analog-to-Digital (A/D) converters. They are also well suited for cell phone PA control loops and video processing (75Ω drive capability) as well as audio and general purpose applications. Single, dual, and quad versions have identical specifications for maximum design flexibility.

The OPA350 series operates on a single supply as low as 2.5V with an input common-mode voltage range that extends 300mV below ground and 300mV above the positive supply. Output voltage swing is to within 10mV of the supply rails with a 10kΩ load. Dual and quad designs feature completely independent circuitry for lowest crosstalk and freedom from interaction.

The single (OPA350) and dual (OPA2350) come in the miniature MSOP-8 surface mount, SO-8 surface mount, and DIP-8 packages. The quad (OPA4350) packages are the space-saving SSOP-16 surface mount and SO-14 surface mount. All are specified from -40°C to +85°C and operate from -55°C to +150°C.

SPICE model available at www.ti.com

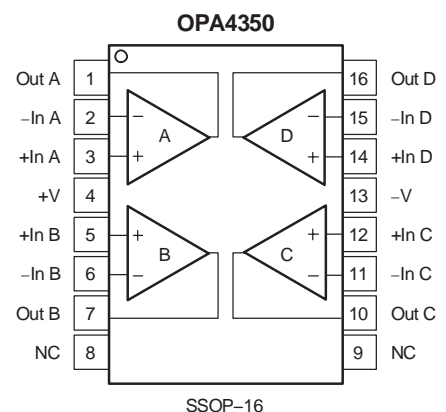
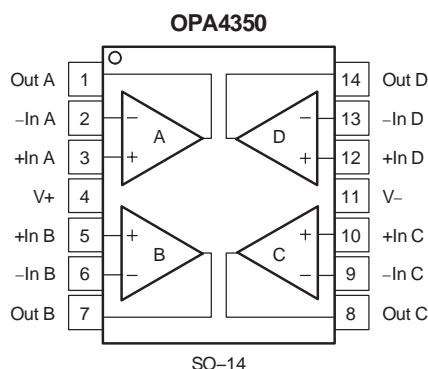
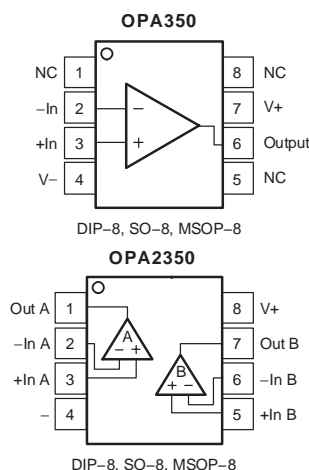

Please be aware that an important notice concerning availability, standard warranty, and use in critical applications of Texas Instruments semiconductor products and disclaimers thereto appears at the end of this data sheet.

All trademarks are the property of their respective owners.

PRODUCTION DATA information is current as of publication date. Products conform to specifications per the terms of Texas Instruments standard warranty. Production processing does not necessarily include testing of all parameters.

ABSOLUTE MAXIMUM RATINGS(1)

Supply Voltage	7.0V
Signal Input Terminals(2), Voltage	(V-) – 0.3V to (V+) + 0.3V
Current	10mA
Open Short-Circuit Current(3)	Continuous
Operating Temperature Range	–55°C to +150°C
Storage Temperature Range	–55°C to +150°C
Junction Temperature	+150°C
Lead Temperature (soldering, 10s)	+300°C

- (1) Stresses above these ratings may cause permanent damage. Exposure to absolute maximum conditions for extended periods may degrade device reliability. These are stress ratings only, and functional operation of the device at these or any other conditions beyond those specified is not implied.
- (2) Input terminals are diode-clamped to the power-supply rails. Input signals that can swing more than 0.3V beyond the supply rails should be current limited to 10mA or less.
- (3) Short-circuit to ground, one amplifier per package.

ELECTROSTATIC DISCHARGE SENSITIVITY



This integrated circuit can be damaged by ESD. Texas Instruments recommends that all integrated circuits be handled with appropriate precautions. Failure to observe proper handling and installation procedures can cause damage.

ESD damage can range from subtle performance degradation to complete device failure. Precision integrated circuits may be more susceptible to damage because very small parametric changes could cause the device not to meet its published specifications.

PACKAGE/ORDERING INFORMATION(1)

PRODUCT	PACKAGE-LEAD	PACKAGE DESIGNATOR	SPECIFIED TEMPERATURE RANGE	PACKAGE MARKING	ORDERING NUMBER	TRANSPORT MEDIA, QUANTITY
SINGLE						
OPA350EA	MSOP-8	DGK	–40°C to +85°C	C50	OPA350EA/250	Tape and Reel, 250
					OPA350EA/2K5	Tape and Reel, 2500
OPA350UA	SO-8	D	–40°C to +85°C	OPA350UA	OPA350UA	Rails
					OPA350UA/2K5	Tape and Reel, 2500
OPA350PA	DIP-8	P	–40°C to +85°C	OPA350PA	OPA350PA	Rails
DUAL						
OPA2350EA	MSOP-8	DGK	–40°C to +85°C	D50	OPA2350EA/250	Tape and Reel, 250
					OPA2350EA/2K5	Tape and Reel, 2500
OPA2350UA	SO-8	D	–40°C to +85°C	OPA2350UA	OPA2350UA	Rails
					OPA2350UA/2K5	Tape and Reel, 2500
OPA2350PA	DIP-8	P	–40°C to +85°C	OPA2350PA	OPA2350PA	Rails
QUAD						
OPA4350EA	SSOP-16	DBQ	–40°C to +85°C	OPA4350EA	OPA4350EA/250	Tape and Reel, 250
					OPA4350EA/2K5	Tape and Reel, 2500
OPA4350UA	SO-14	D	–40°C to +85°C	OPA4350UA	OPA4350UA	Rails
					OPA4350UA/2K5	Tape and Reel, 2500

(1) For the most current package and ordering information, see the Package Option Addendum located at the end of this data sheet.

ELECTRICAL CHARACTERISTICS: $V_S = 2.7V$ to $5.5V$

Boldface limits apply over the temperature range, $T_A = -40^\circ C$ to $+85^\circ C$. $V_S = 5V$.

All specifications at $T_A = +25^\circ C$, $R_L = 1k\Omega$ connected to $V_S/2$ and $V_{OUT} = V_S/2$, unless otherwise noted.

PARAMETER	TEST CONDITIONS	OPA350, OPA2350, OPA4350			UNIT
		MIN	TYP ⁽¹⁾	MAX	
OFFSET VOLTAGE					
Input Offset Voltage	V_{OS}		± 150	± 500	μV
$T_A = -40^\circ C$ to $+85^\circ C$				± 1	mV
vs Temperature			± 4		$\mu V/^\circ C$
vs Power-Supply Rejection Ratio	PSRR	$V_S = 2.7V$ to $5.5V$, $V_{CM} = 0V$	40	150	$\mu V/V$
$T_A = -40^\circ C$ to $+85^\circ C$		$V_S = 2.7V$ to $5.5V$, $V_{CM} = 0V$		175	$\mu V/V$
Channel Separation (dual, quad)		dc	0.15		$\mu V/V$
INPUT BIAS CURRENT					
Input Bias Current	I_B		± 0.5	± 10	pA
vs Temperature			See Typical Characteristics		
Input Offset Current	I_{OS}		± 0.5	± 10	pA
NOISE					
Input Voltage Noise, $f = 100Hz$ to $400kHz$			4		μV_{rms}
Input Voltage Noise Density, $f = 10kHz$	e_n		7		nV/\sqrt{Hz}
Input Current Noise Density, $f = 100kHz$			5		nV/\sqrt{Hz}
Current Noise Density, $f = 10kHz$	i_n		4		fA/\sqrt{Hz}
INPUT VOLTAGE RANGE					
Common-Mode Voltage Range	V_{CM}	$T_A = -40^\circ C$ to $+85^\circ C$	-0.1	(V+) + 0.1	V
Common-Mode Rejection Ratio	CMRR	$V_S = 2.7V$, $-0.1V < V_{CM} < 2.8V$	66	84	dB
		$V_S = 5.5V$, $-0.1V < V_{CM} < 5.6V$	74	90	dB
$T_A = -40^\circ C$ to $+85^\circ C$		$V_S = 5.5V$, $-0.1V < V_{CM} < 5.6V$	74		dB
INPUT IMPEDANCE					
Differential			$10^{13} \parallel 2.5$		$\Omega \parallel pF$
Common-Mode			$10^{13} \parallel 6.5$		$\Omega \parallel pF$
OPEN-LOOP GAIN					
Open-Loop Voltage Gain	A_{OL}	$R_L = 10k\Omega$, $50mV < V_O < (V+) - 50mV$	100	122	dB
$T_A = -40^\circ C$ to $+85^\circ C$		$R_L = 10k\Omega$, $50mV < V_O < (V+) - 50mV$	100		dB
		$R_L = 1k\Omega$, $200mV < V_O < (V+) - 200mV$	100	120	dB
$T_A = -40^\circ C$ to $+85^\circ C$		$R_L = 1k\Omega$, $200mV < V_O < (V+) - 200mV$	100		dB
FREQUENCY RESPONSE					
Gain-Bandwidth Product	GBW	$C_L = 100pF$		38	MHz
Slew Rate	SR	$G = 1$		22	$V/\mu s$
Settling Time: 0.1%		$G = \pm 1$, 2V Step		0.22	μs
0.01%		$G = \pm 1$, 2V Step		0.5	μs
Overload Recovery Time		$V_{IN} \bullet G = V_S$		0.1	μs
Total Harmonic Distortion + Noise	THD+N	$R_L = 600\Omega$, $V_O = 2.5V_{pp}^{(2)}$, $G = 1$, $f = 1kHz$		0.0006	%
Differential Gain Error		$G = 2$, $R_L = 600\Omega$, $V_O = 1.4V^{(3)}$		0.17	%
Differential Phase Error		$G = 2$, $R_L = 600\Omega$, $V_O = 1.4V^{(3)}$		0.17	deg

(1) $V_S = +5V$.

(2) $V_{OUT} = 0.25V$ to $2.75V$.

(3) NTSC signal generator used. See Figure 6 for test circuit.

(4) Output voltage swings are measured between the output and power supply rails.

(5) See typical characteristic curve, *Output Voltage Swing vs Output Current*.

ELECTRICAL CHARACTERISTICS: $V_S = 2.7V$ to $5.5V$ (continued)

Boldface limits apply over the temperature range, $T_A = -40^\circ\text{C}$ to $+85^\circ\text{C}$. $V_S = 5V$.

All specifications at $T_A = +25^\circ\text{C}$, $R_L = 1\text{k}\Omega$ connected to $V_S/2$ and $V_{OUT} = V_S/2$, unless otherwise noted.

PARAMETER	TEST CONDITIONS	OPA350, OPA2350, OPA4350			UNIT	
		MIN	TYP ⁽¹⁾	MAX		
OUTPUT						
Voltage Output Swing from Rail ⁽⁴⁾	V_{OUT}	$R_L = 10\text{k}\Omega$, $A_{OL} \geq 100\text{dB}$	10	50	mV	
$T_A = -40^\circ\text{C}$ to $+85^\circ\text{C}$		$R_L = 10\text{k}\Omega$, $A_{OL} \geq 100\text{dB}$		50	mV	
		$R_L = 1\text{k}\Omega$, $A_{OL} \geq 100\text{dB}$	25	200	mV	
$T_A = -40^\circ\text{C}$ to $+85^\circ\text{C}$		$R_L = 1\text{k}\Omega$, $A_{OL} \geq 100\text{dB}$		200	mV	
Output Current	I_{OUT}		± 40 ⁽⁵⁾		mA	
Short-Circuit Current	I_{SC}		± 80		mA	
Capacitive Load Drive	C_{LOAD}		See Typical Characteristics			
POWER SUPPLY						
Operating Voltage Range	V_S	$T_A = -40^\circ\text{C}$ to $+85^\circ\text{C}$	2.7		5.5	V
Minimum Operating Voltage				2.5		V
Quiescent Current (per amplifier)	I_Q	$I_O = 0$		5.2	7.5	mA
$T_A = -40^\circ\text{C}$ to $+85^\circ\text{C}$		$I_O = 0$			8.5	mA
TEMPERATURE RANGE						
Specified Range			-40		+85	$^\circ\text{C}$
Operating Range			-55		+150	$^\circ\text{C}$
Storage Range			-55		+150	$^\circ\text{C}$
Thermal Resistance	θ_{JA}					
MSOP-8 Surface Mount				150		$^\circ\text{C}/\text{W}$
SO-8 Surface Mount				150		$^\circ\text{C}/\text{W}$
DIP-8				100		$^\circ\text{C}/\text{W}$
SO-14 Surface Mount				100		$^\circ\text{C}/\text{W}$
SSOP-16 Surface Mount				100		$^\circ\text{C}/\text{W}$

(1) $V_S = +5V$.

(2) $V_{OUT} = 0.25V$ to $2.75V$.

(3) NTSC signal generator used. See Figure 6 for test circuit.

(4) Output voltage swings are measured between the output and power supply rails.

(5) See typical characteristic curve, *Output Voltage Swing vs Output Current*.

TYPICAL CHARACTERISTICS

All specifications at $T_A = +25^\circ\text{C}$, $V_S = +5\text{V}$, and $R_L = 1\text{k}\Omega$ connected to $V_S/2$, unless otherwise noted.

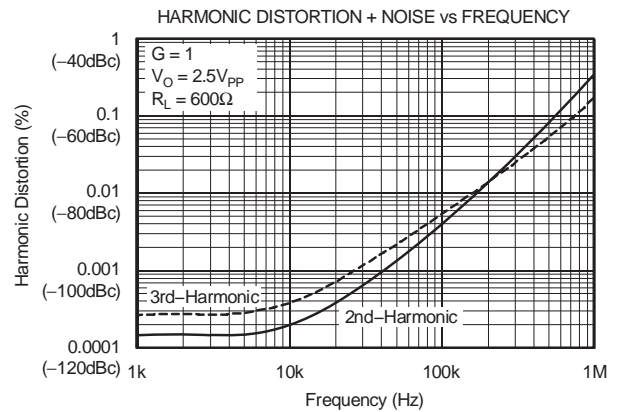
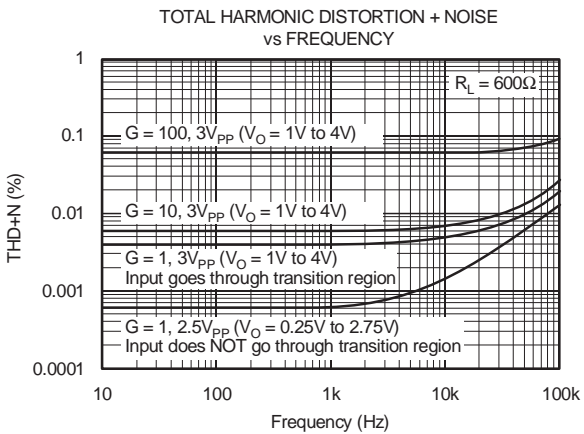
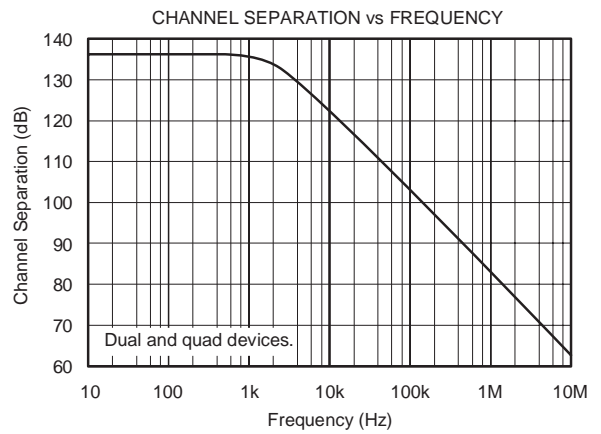
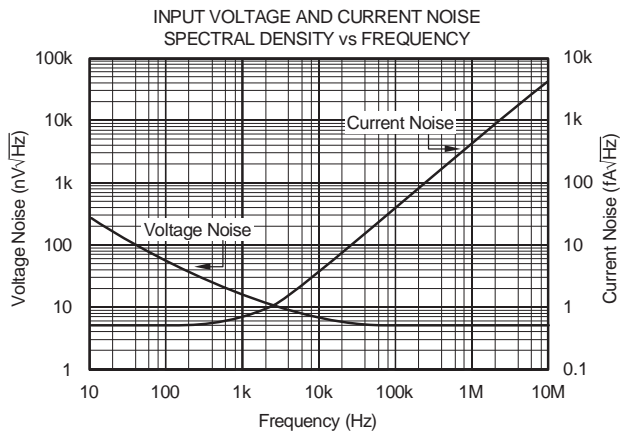
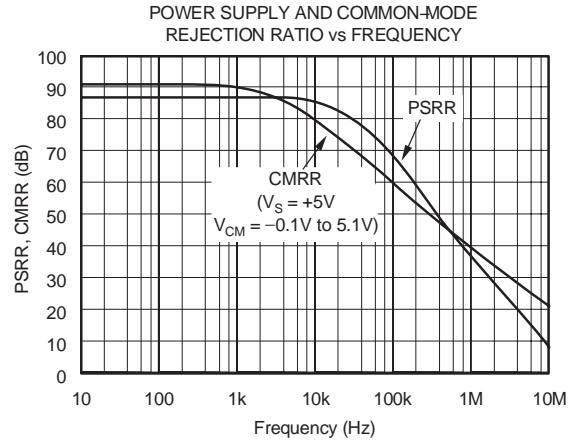
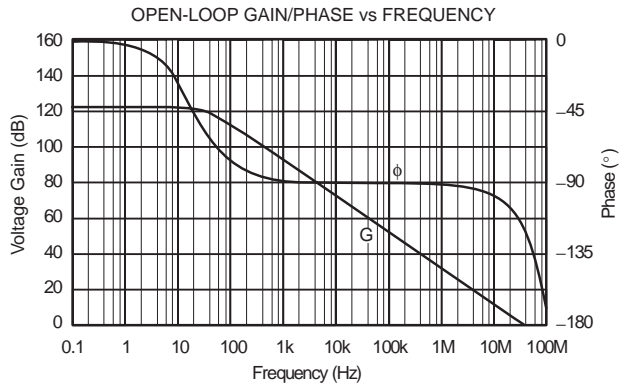

TYPICAL CHARACTERISTICS (continued)

All specifications at $T_A = +25^\circ\text{C}$, $V_S = +5\text{V}$, and $R_L = 1\text{k}\Omega$ connected to $V_S/2$, unless otherwise noted.

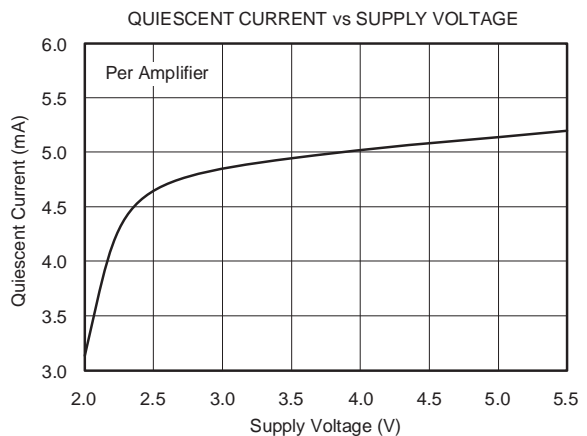
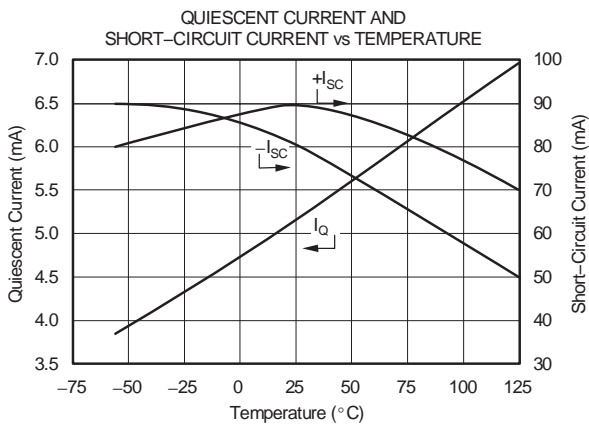
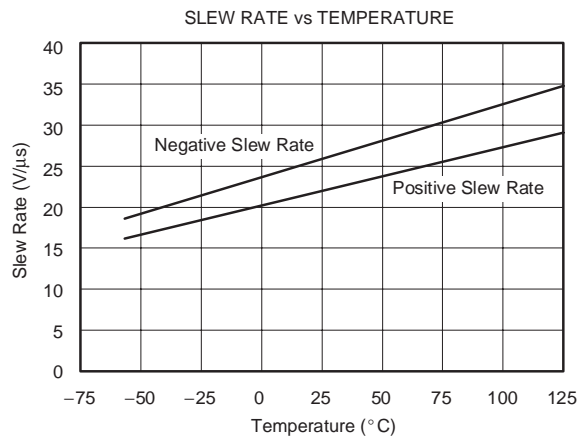
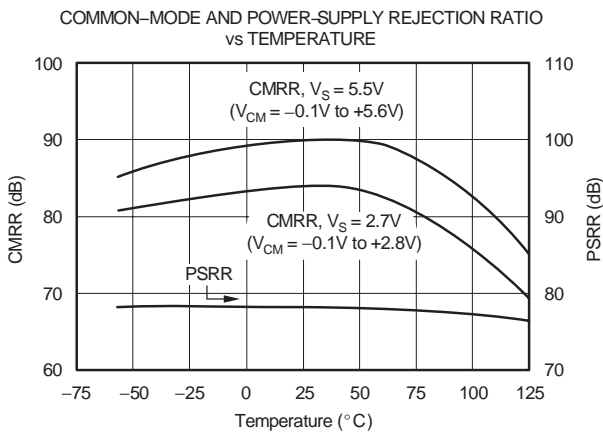
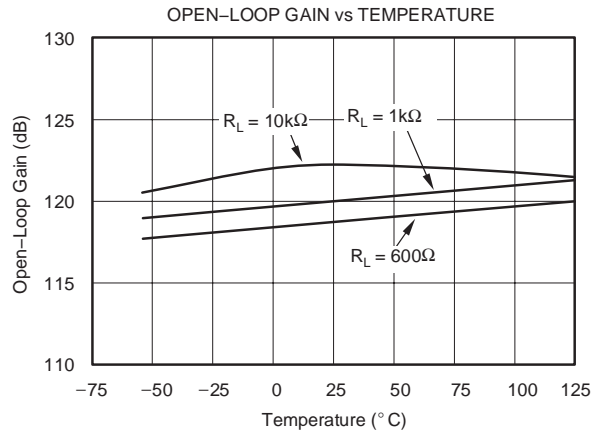
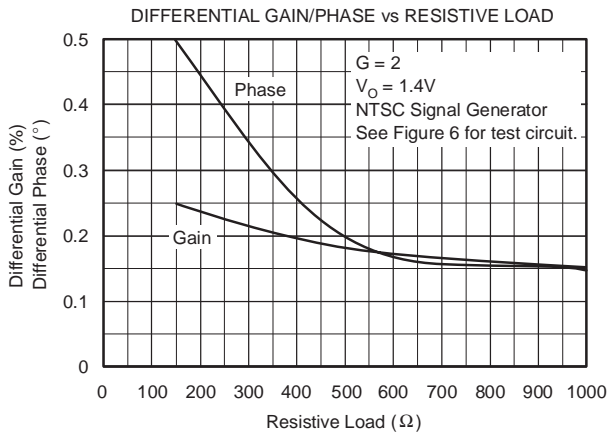

TYPICAL CHARACTERISTICS (continued)

All specifications at $T_A = +25^\circ\text{C}$, $V_S = +5\text{V}$, and $R_L = 1\text{k}\Omega$ connected to $V_S/2$, unless otherwise noted.

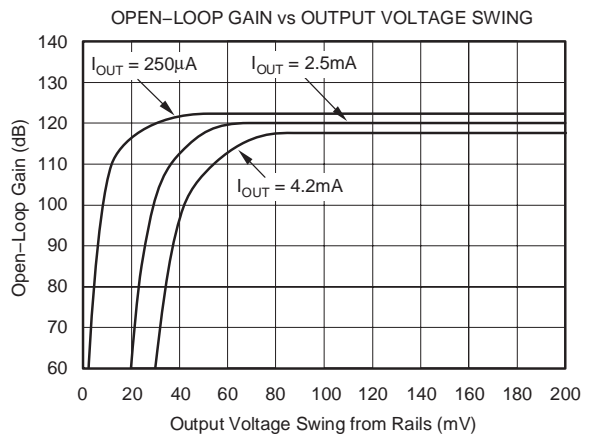
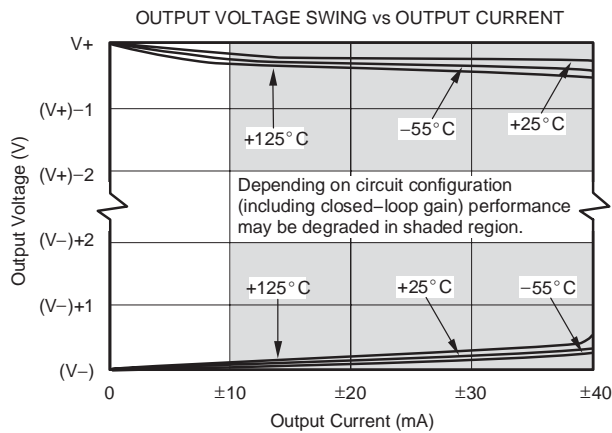
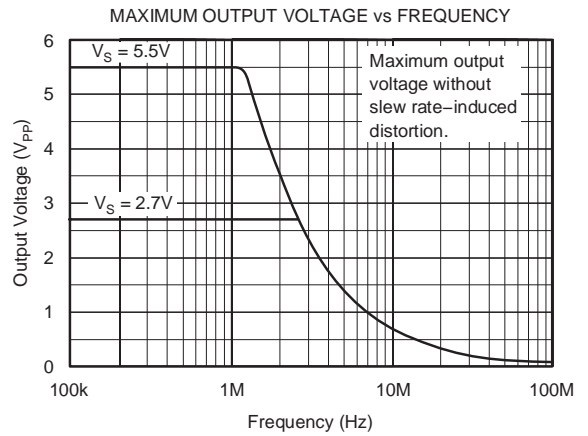
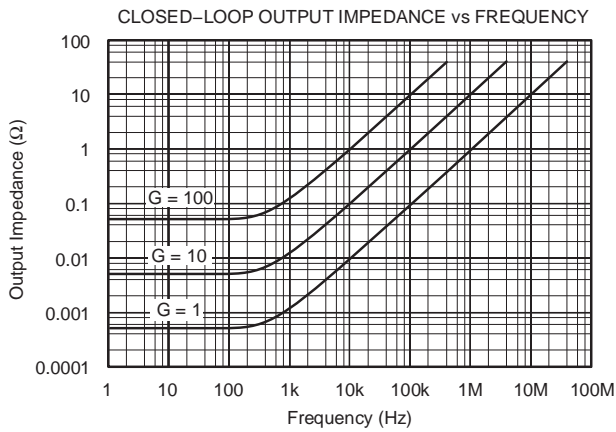
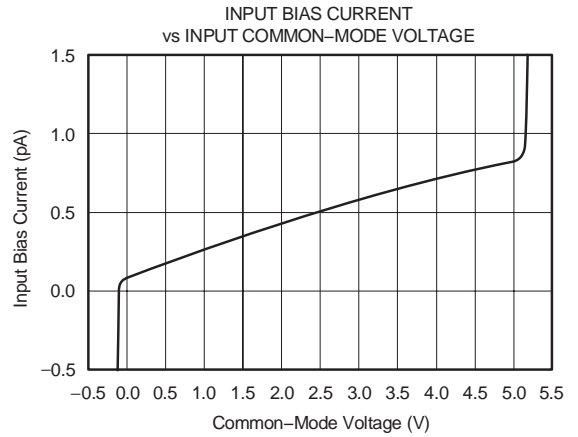
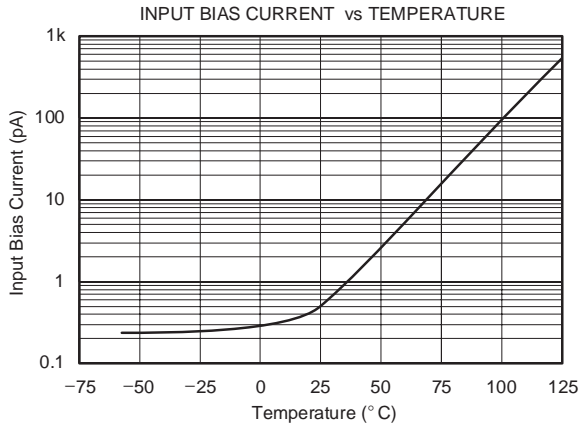

TYPICAL CHARACTERISTICS (continued)

All specifications at $T_A = +25^\circ\text{C}$, $V_S = +5\text{V}$, and $R_L = 1\text{k}\Omega$ connected to $V_S/2$, unless otherwise noted.

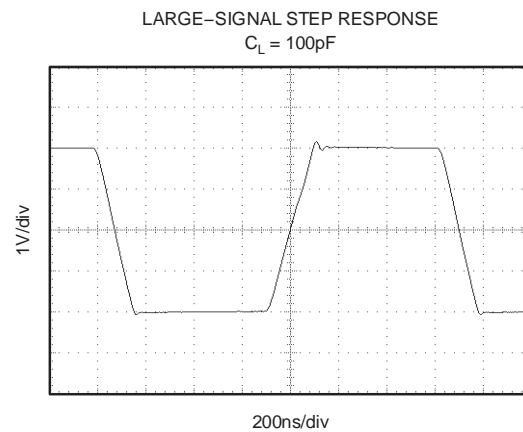
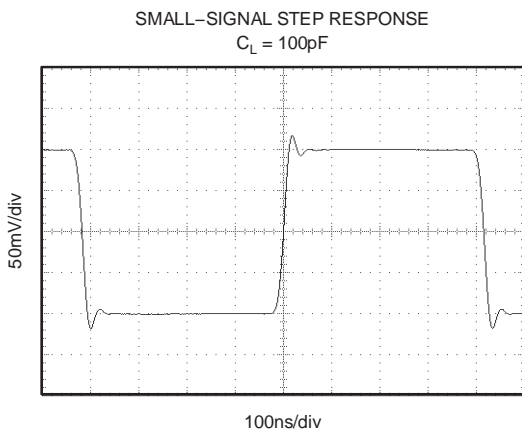
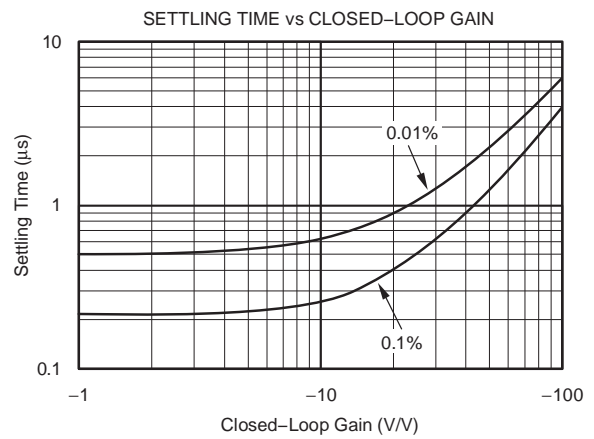
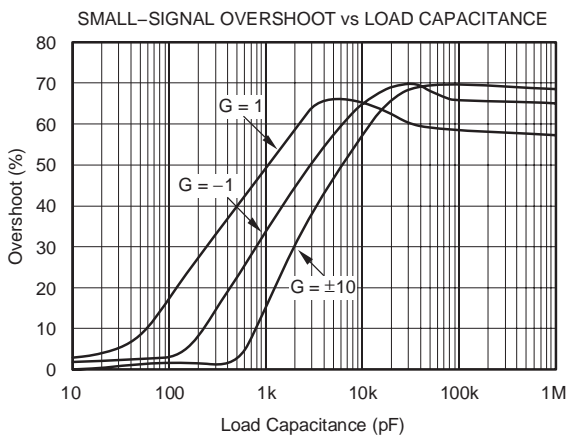
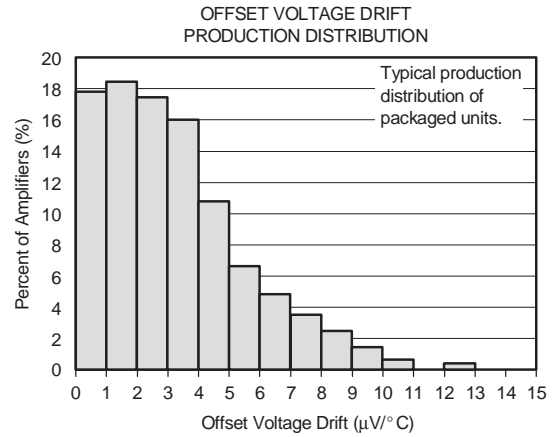
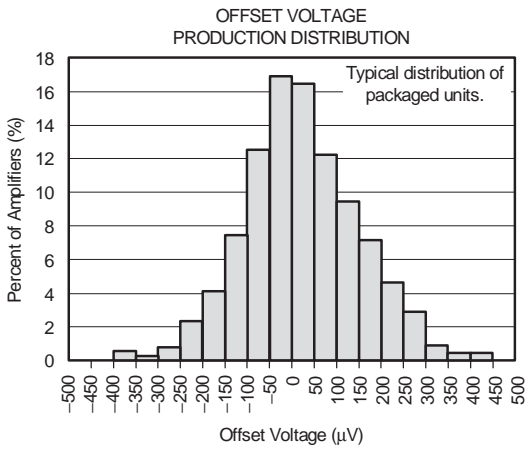

APPLICATIONS INFORMATION

OPA350 series op amps are fabricated on a state-of-the-art 0.6 micron CMOS process. They are unity-gain stable and suitable for a wide range of general-purpose applications. Rail-to-rail input/output make them ideal for driving sampling A/D converters. They are also well-suited for controlling the output power in cell phones. These applications often require high speed and low noise. In addition, the OPA350 series offers a low-cost solution for general-purpose and consumer video applications (75Ω drive capability).

Excellent ac performance makes the OPA350 series well-suited for audio applications. Their bandwidth, slew rate, low noise (5nV/√Hz), low THD (0.0006%), and small package options are ideal for these applications. The class AB output stage is capable of driving 600Ω loads connected to any point between V+ and ground.

Rail-to-rail input and output swing significantly increases dynamic range, especially in low voltage supply applications. Figure 1 shows the input and output waveforms for the OPA350 in unity-gain configuration. Operation is from a single +5V supply with a 1kΩ load connected to V_S/2. The input is a 5V_{PP} sinusoid. Output voltage swing is approximately 4.95V_{PP}.

Power supply pins should be bypassed with 0.01μF ceramic capacitors.

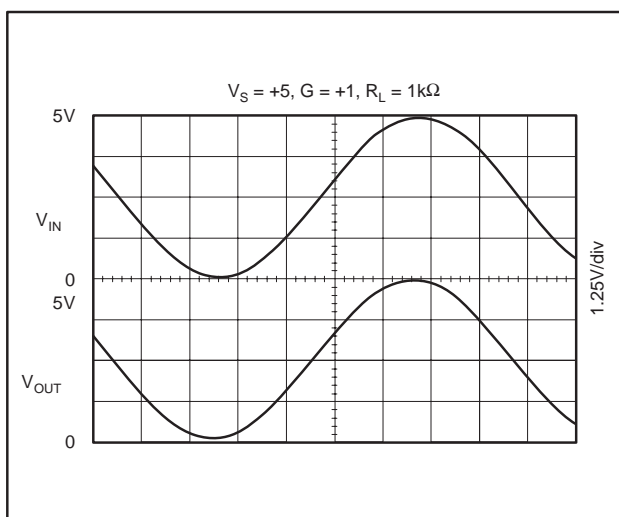

Figure 1. Rail-to-Rail Input and Output

OPERATING VOLTAGE

OPA350 series op amps are fully specified from +2.7V to +5.5V. However, supply voltage may range from +2.5V to +5.5V. Parameters are tested over the specified supply range—a unique feature of the OPA350 series. In addition, many specifications apply from –40°C to +85°C. Most behavior remains virtually unchanged throughout the full operating voltage range. Parameters that vary significantly with operating voltage or temperature are shown in the typical characteristics.

RAIL-TO-RAIL INPUT

The tested input common-mode voltage range of the OPA350 series extends 100mV beyond the supply rails. This is achieved with a complementary input stage—an N-channel input differential pair in parallel with a P-channel differential pair, as shown in Figure 2. The N-channel pair is active for input voltages close to the positive rail, typically (V+) – 1.8V to 100mV above the positive supply, while the P-channel pair is on for inputs from 100mV below the negative supply to approximately (V+) – 1.8V. There is a small transition region, typically (V+) – 2V to (V+) – 1.6V, in which both pairs are on. This 400mV transition region can vary ±400mV with process variation. Thus, the transition region (both input stages on) can range from (V+) – 2.4V to (V+) – 2.0V on the low end, up to (V+) – 1.6V to (V+) – 1.2V on the high end.

OPA350 series op amps are laser-trimmed to reduce offset voltage difference between the N-channel and P-channel input stages, resulting in improved common-mode rejection and a smooth transition between the N-channel pair and the P-channel pair. However, within the 400mV transition region PSRR, CMRR, offset voltage, offset drift, and THD may be degraded compared to operation outside this region.

A double-folded cascode adds the signal from the two input pairs and presents a differential signal to the class AB output stage. Normally, input bias current is approximately 500fA. However, large inputs (greater than 300mV beyond the supply rails) can turn on the OPA350's input protection diodes, causing excessive current to flow in or out of the input pins. Momentary voltages greater than 300mV beyond the power supply can be tolerated if the current on the input pins is limited to 10mA. This is easily accomplished with an input resistor, as shown in Figure 3. Many input signals are inherently current-limited to less than 10mA; therefore, a limiting resistor is not required.

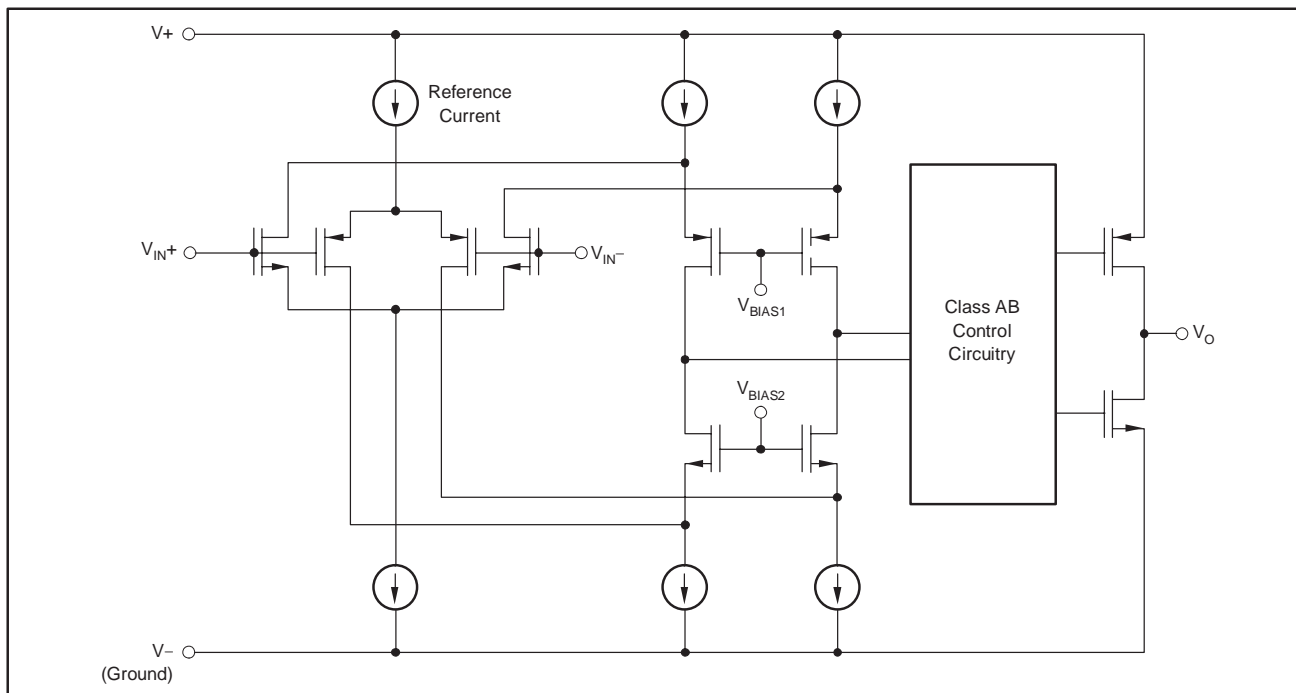

Figure 2. Simplified Schematic

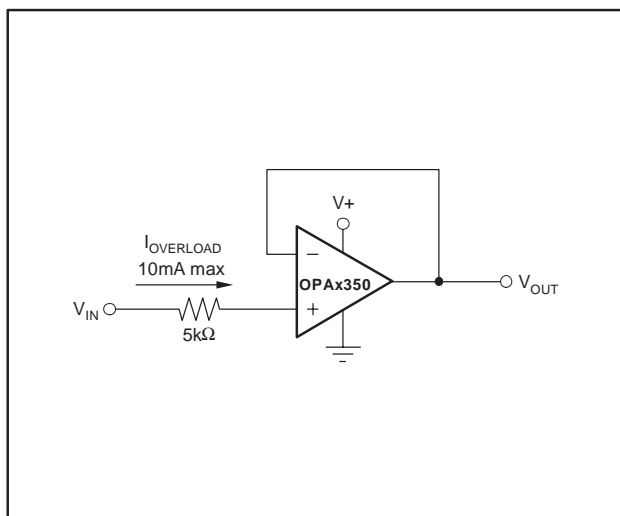

Figure 3. Input Current Protection for Voltages Exceeding the Supply Voltage

RAIL-TO-RAIL OUTPUT

A class AB output stage with common-source transistors is used to achieve rail-to-rail output. For light resistive loads ($>10k\Omega$), the output voltage swing is typically ten millivolts from the supply rails. With heavier resistive loads (600Ω to $10k\Omega$), the output can swing to

within a few tens of millivolts from the supply rails and maintain high open-loop gain. See the typical characteristics *Output Voltage Swing vs Output Current* and *Open-Loop Gain vs Output Voltage*.

CAPACITIVE LOAD AND STABILITY

OPA350 series op amps can drive a wide range of capacitive loads. However, all op amps under certain conditions may become unstable. Op amp configuration, gain, and load value are just a few of the factors to consider when determining stability. An op amp in unity-gain configuration is the most susceptible to the effects of capacitive load. The capacitive load reacts with the op amp's output impedance, along with any additional load resistance, to create a pole in the small-signal response that degrades the phase margin.

In unity gain, OPA350 series op amps perform well with very large capacitive loads. Increasing gain enhances the amplifier's ability to drive more capacitance. The typical characteristic *Small-Signal Overshoot vs Capacitive Load* shows performance with a $1k\Omega$ resistive load. Increasing load resistance improves capacitive load drive capability.

FEEDBACK CAPACITOR IMPROVES RESPONSE

For optimum settling time and stability with high-impedance feedback networks, it may be necessary to add a feedback capacitor across the feedback resistor, R_F , as shown in Figure 4. This capacitor compensates for the zero created by the feedback network impedance and the OPA350's input capacitance (and any parasitic layout capacitance). The effect becomes more significant with higher impedance networks.

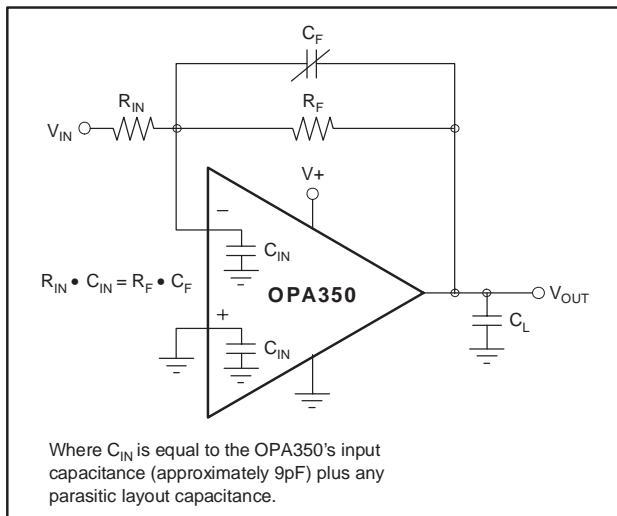

Figure 4. Feedback Capacitor Improves Dynamic Performance

It is suggested that a variable capacitor be used for the feedback capacitor since input capacitance may vary between op amps and layout capacitance is difficult to determine. For the circuit shown in Figure 4, the value of the variable feedback capacitor should be chosen so that the input resistance times the input capacitance of the OPA350 (typically 9pF) plus the estimated parasitic layout capacitance equals the feedback capacitor times the feedback resistor:

$$R_{IN} \cdot C_{IN} = R_F \cdot C_F$$

where C_{IN} is equal to the OPA350's input capacitance (sum of differential and common-mode) plus the layout capacitance. The capacitor can be varied until optimum performance is obtained.

DRIVING A/D CONVERTERS

OPA350 series op amps are optimized for driving medium speed (up to 500kHz) sampling A/D converters. However, they also offer excellent performance for higher speed converters. The OPA350

series provides an effective means of buffering the A/D's input capacitance and resulting charge injection while providing signal gain.

Figure 5 shows the OPA350 driving an ADS7861. The ADS7861 is a dual, 500kHz, 12-bit sampling converter in the tiny SSOP-24 package. When used with the miniature package options of the OPA350 series, the combination is ideal for space-limited applications. For further information, consult the ADS7861 data sheet (SBAS110A).

OUTPUT IMPEDANCE

The low frequency open-loop output impedance of the OPA350's common-source output stage is approximately 1k Ω . When the op amp is connected with feedback, this value is reduced significantly by the loop gain of the op amp. For example, with 122dB of open-loop gain, the output impedance is reduced in unity-gain to less than 0.001 Ω . For each decade rise in the closed-loop gain, the loop gain is reduced by the same amount which results in a ten-fold increase in effective output impedance (see the typical characteristic, *Output Impedance vs Frequency*).

At higher frequencies, the output impedance will rise as the open-loop gain of the op amp drops. However, at these frequencies the output also becomes capacitive due to parasitic capacitance. This prevents the output impedance from becoming too high, which can cause stability problems when driving capacitive loads. As mentioned previously, the OPA350 has excellent capacitive load drive capability for an op amp with its bandwidth.

VIDEO LINE DRIVER

Figure 6 shows a circuit for a single supply, $G = 2$ composite video line driver. The synchronized outputs of a composite video line driver extend below ground. As shown, the input to the op amp should be ac-coupled and shifted positively to provide adequate signal swing to account for these negative signals in a single-supply configuration.

The input is terminated with a 75 Ω resistor and ac-coupled with a 47 μ F capacitor to a voltage divider that provides the dc bias point to the input. In Figure 6, this point is approximately $(V_-) + 1.7V$. Setting the optimal bias point requires some understanding of the nature of composite video signals. For best performance, one should be careful to avoid the distortion caused by the transition region of the OPA350's complementary input stage. Refer to the discussion of rail-to-rail input.

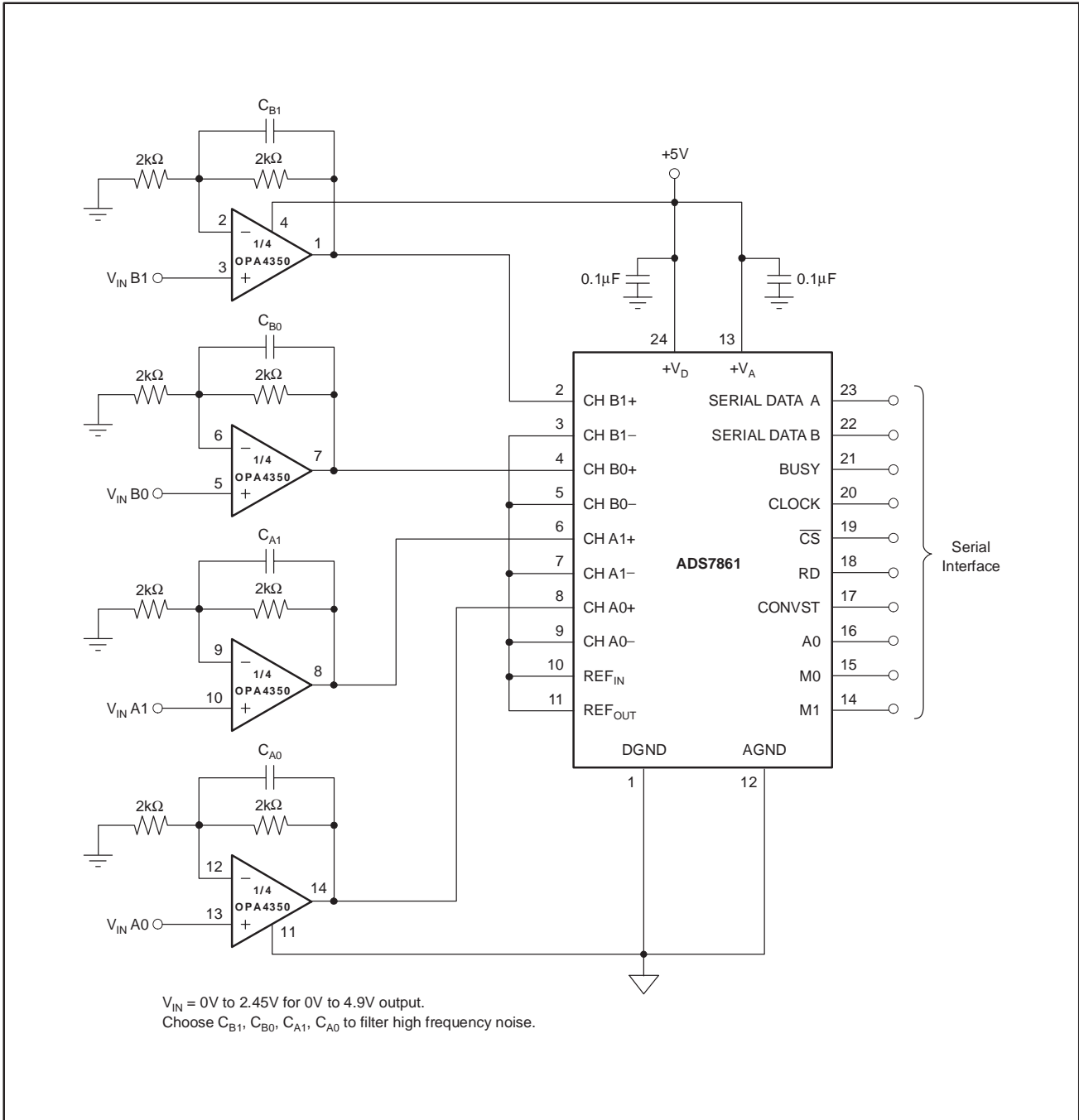

Figure 5. OPA4350 Driving Sampling A/D Converter

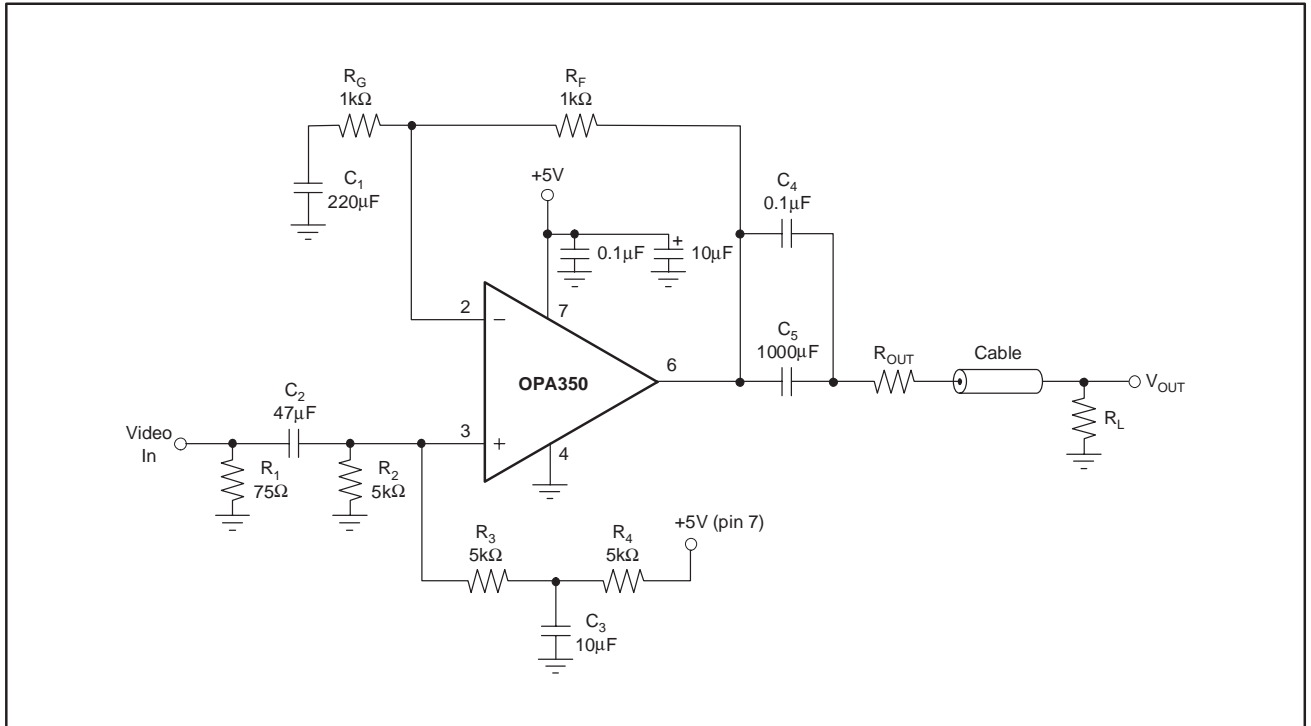

Figure 6. Single-Supply Video Line Driver

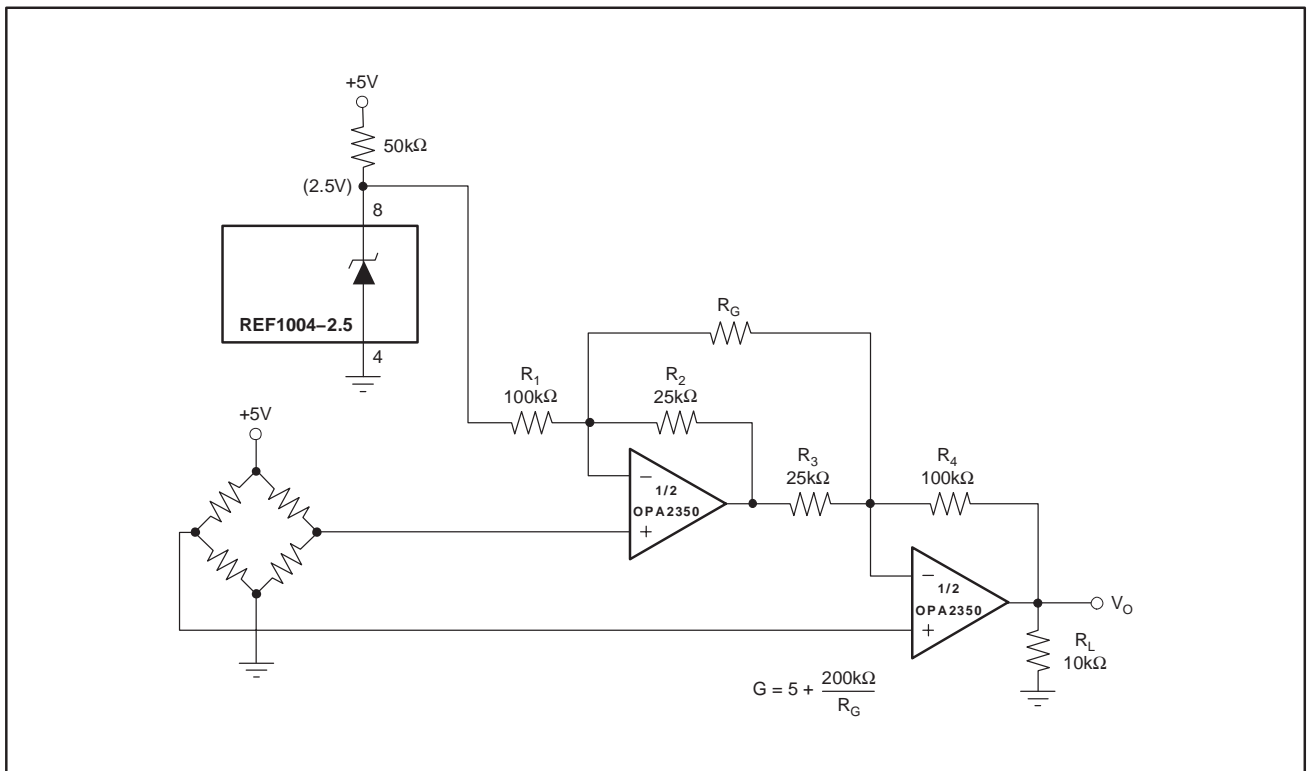

Figure 7. Two Op-Amp Instrumentation Amplifier With Improved High Frequency Common-Mode Rejection

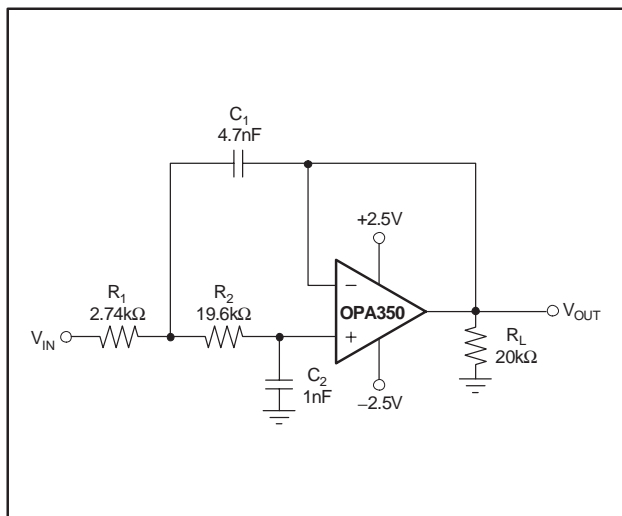

Figure 8. 10kHz Low-Pass Filter

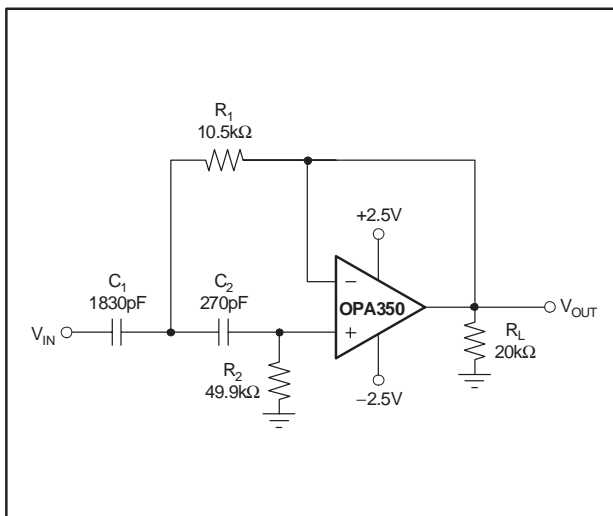

Figure 9. 10kHz High-Pass Filter

PACKAGING INFORMATION

Orderable Device	Status ⁽¹⁾	Package Type	Package Drawing	Pins	Package Qty	Eco Plan ⁽²⁾	Lead/Ball Finish	MSL Peak Temp ⁽³⁾
OPA2350EA/250	ACTIVE	MSOP	DGK	8	250	Green (RoHS & no Sb/Br)	CU NIPDAU	Level-2-260C-1 YEAR
OPA2350EA/250G4	ACTIVE	MSOP	DGK	8	250	Green (RoHS & no Sb/Br)	CU NIPDAU	Level-2-260C-1 YEAR
OPA2350EA/2K5	ACTIVE	MSOP	DGK	8	2500	Green (RoHS & no Sb/Br)	CU NIPDAU	Level-2-260C-1 YEAR
OPA2350EA/2K5G4	ACTIVE	MSOP	DGK	8	2500	Green (RoHS & no Sb/Br)	CU NIPDAU	Level-2-260C-1 YEAR
OPA2350PA	ACTIVE	PDIP	P	8	50	Green (RoHS & no Sb/Br)	CU NIPDAU	N / A for Pkg Type
OPA2350PAG4	ACTIVE	PDIP	P	8	50	Green (RoHS & no Sb/Br)	CU NIPDAU	N / A for Pkg Type
OPA2350UA	ACTIVE	SOIC	D	8	100	Green (RoHS & no Sb/Br)	CU NIPDAU	Level-2-260C-1 YEAR
OPA2350UA/2K5	ACTIVE	SOIC	D	8	2500	Green (RoHS & no Sb/Br)	CU NIPDAU	Level-2-260C-1 YEAR
OPA2350UA/2K5G4	ACTIVE	SOIC	D	8	2500	Green (RoHS & no Sb/Br)	CU NIPDAU	Level-2-260C-1 YEAR
OPA2350UAG4	ACTIVE	SOIC	D	8	100	Green (RoHS & no Sb/Br)	CU NIPDAU	Level-2-260C-1 YEAR
OPA350EA/250	ACTIVE	MSOP	DGK	8	250	Green (RoHS & no Sb/Br)	CU NIPDAU	Level-2-260C-1 YEAR
OPA350EA/250G4	ACTIVE	MSOP	DGK	8	250	Green (RoHS & no Sb/Br)	CU NIPDAU	Level-2-260C-1 YEAR
OPA350EA/2K5	ACTIVE	MSOP	DGK	8	2500	Green (RoHS & no Sb/Br)	CU NIPDAU	Level-2-260C-1 YEAR
OPA350EA/2K5G4	ACTIVE	MSOP	DGK	8	2500	Green (RoHS & no Sb/Br)	CU NIPDAU	Level-2-260C-1 YEAR
OPA350PA	ACTIVE	PDIP	P	8	50	Green (RoHS & no Sb/Br)	CU NIPDAU	N / A for Pkg Type
OPA350PAG4	ACTIVE	PDIP	P	8	50	Green (RoHS & no Sb/Br)	CU NIPDAU	N / A for Pkg Type
OPA350UA	ACTIVE	SOIC	D	8	100	Green (RoHS & no Sb/Br)	CU NIPDAU	Level-2-260C-1 YEAR
OPA350UA/2K5	ACTIVE	SOIC	D	8	2500	Green (RoHS & no Sb/Br)	CU NIPDAU	Level-2-260C-1 YEAR
OPA350UA/2K5G4	ACTIVE	SOIC	D	8	2500	Green (RoHS & no Sb/Br)	CU NIPDAU	Level-2-260C-1 YEAR
OPA350UAG4	ACTIVE	SOIC	D	8	100	Green (RoHS & no Sb/Br)	CU NIPDAU	Level-2-260C-1 YEAR
OPA4350EA/250	ACTIVE	SSOP/ QSOP	DBQ	16	250	Green (RoHS & no Sb/Br)	CU NIPDAU	Level-2-260C-1 YEAR
OPA4350EA/250G4	ACTIVE	SSOP/ QSOP	DBQ	16	250	Green (RoHS & no Sb/Br)	CU NIPDAU	Level-2-260C-1 YEAR
OPA4350EA/2K5	ACTIVE	SSOP/ QSOP	DBQ	16	2500	Green (RoHS & no Sb/Br)	CU NIPDAU	Level-2-260C-1 YEAR
OPA4350EA/2K5G4	ACTIVE	SSOP/ QSOP	DBQ	16	2500	Green (RoHS & no Sb/Br)	CU NIPDAU	Level-2-260C-1 YEAR
OPA4350UA	ACTIVE	SOIC	D	14	58	Green (RoHS & no Sb/Br)	CU NIPDAU	Level-2-260C-1 YEAR

Orderable Device	Status ⁽¹⁾	Package Type	Package Drawing	Pins	Package Qty	Eco Plan ⁽²⁾	Lead/Ball Finish	MSL Peak Temp ⁽³⁾
OPA4350UA/2K5	ACTIVE	SOIC	D	14	2500	Green (RoHS & no Sb/Br)	CU NIPDAU	Level-2-260C-1 YEAR
OPA4350UA/2K5G4	ACTIVE	SOIC	D	14	2500	Green (RoHS & no Sb/Br)	CU NIPDAU	Level-2-260C-1 YEAR
OPA4350UAG4	ACTIVE	SOIC	D	14	58	Green (RoHS & no Sb/Br)	CU NIPDAU	Level-2-260C-1 YEAR

⁽¹⁾ The marketing status values are defined as follows:

ACTIVE: Product device recommended for new designs.

LIFEBUY: TI has announced that the device will be discontinued, and a lifetime-buy period is in effect.

NRND: Not recommended for new designs. Device is in production to support existing customers, but TI does not recommend using this part in a new design.

PREVIEW: Device has been announced but is not in production. Samples may or may not be available.

OBSELETE: TI has discontinued the production of the device.

⁽²⁾ Eco Plan - The planned eco-friendly classification: Pb-Free (RoHS), Pb-Free (RoHS Exempt), or Green (RoHS & no Sb/Br) - please check <http://www.ti.com/productcontent> for the latest availability information and additional product content details.

TBD: The Pb-Free/Green conversion plan has not been defined.

Pb-Free (RoHS): TI's terms "Lead-Free" or "Pb-Free" mean semiconductor products that are compatible with the current RoHS requirements for all 6 substances, including the requirement that lead not exceed 0.1% by weight in homogeneous materials. Where designed to be soldered at high temperatures, TI Pb-Free products are suitable for use in specified lead-free processes.

Pb-Free (RoHS Exempt): This component has a RoHS exemption for either 1) lead-based flip-chip solder bumps used between the die and package, or 2) lead-based die adhesive used between the die and leadframe. The component is otherwise considered Pb-Free (RoHS compatible) as defined above.

Green (RoHS & no Sb/Br): TI defines "Green" to mean Pb-Free (RoHS compatible), and free of Bromine (Br) and Antimony (Sb) based flame retardants (Br or Sb do not exceed 0.1% by weight in homogeneous material)

⁽³⁾ MSL, Peak Temp. -- The Moisture Sensitivity Level rating according to the JEDEC industry standard classifications, and peak solder temperature.

Important Information and Disclaimer:The information provided on this page represents TI's knowledge and belief as of the date that it is provided. TI bases its knowledge and belief on information provided by third parties, and makes no representation or warranty as to the accuracy of such information. Efforts are underway to better integrate information from third parties. TI has taken and continues to take reasonable steps to provide representative and accurate information but may not have conducted destructive testing or chemical analysis on incoming materials and chemicals. TI and TI suppliers consider certain information to be proprietary, and thus CAS numbers and other limited information may not be available for release.

In no event shall TI's liability arising out of such information exceed the total purchase price of the TI part(s) at issue in this document sold by TI to Customer on an annual basis.

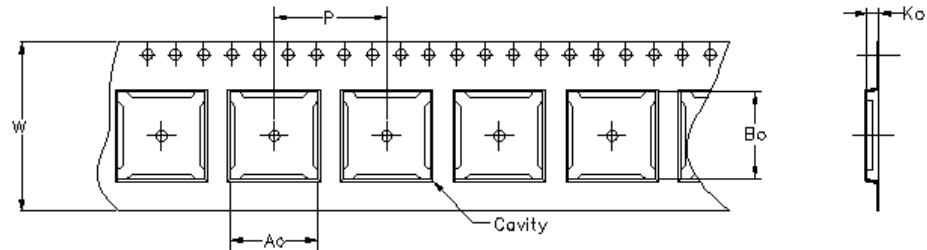

Carrier tape design is defined largely by the component length, width, and thickness.

A_o = Dimension designed to accommodate the component width.
B_o = Dimension designed to accommodate the component length.
K_o = Dimension designed to accommodate the component thickness.
W = Overall width of the carrier tape.
P = Pitch between successive cavity centers.

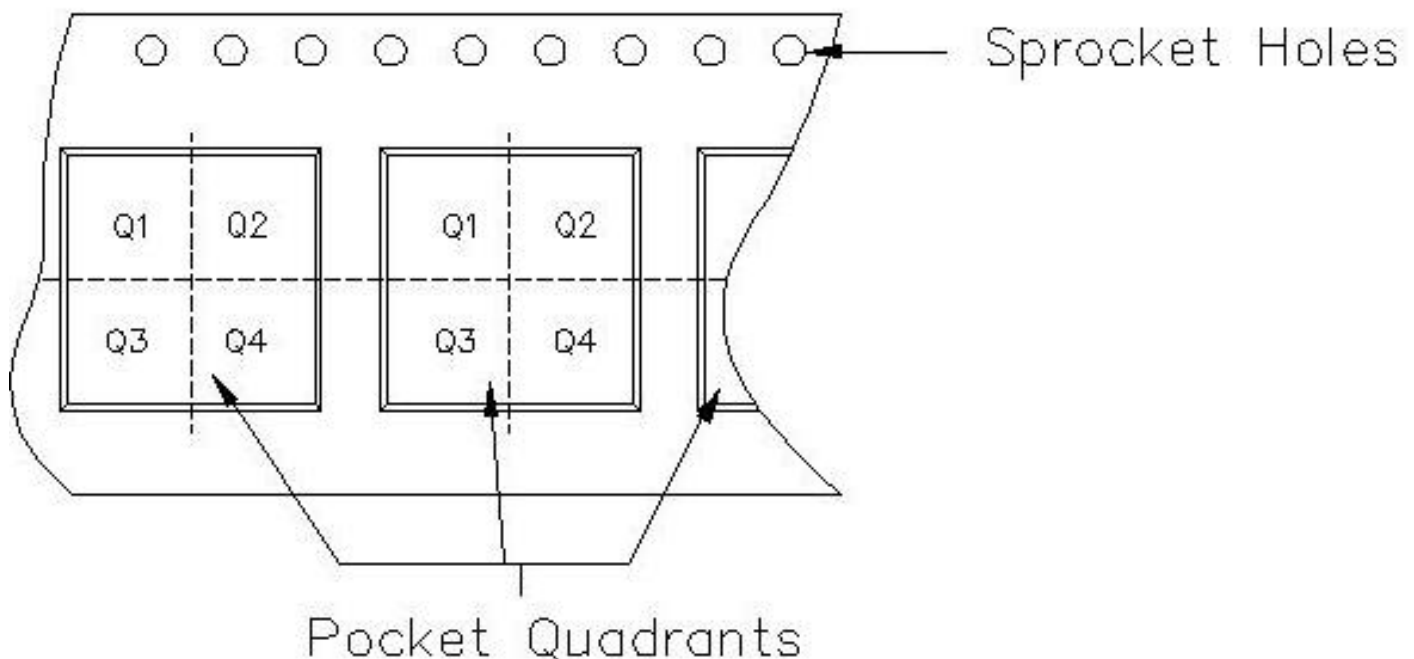

TAPE AND REEL INFORMATION

Device	Package	Pins	Site	Reel Diameter (mm)	Reel Width (mm)	A0 (mm)	B0 (mm)	K0 (mm)	P1 (mm)	W (mm)	Pin1 Quadrant
OPA2350EA/250	DGK	8	MLA	180	12	5.2	3.3	1.6	12	12	Q1
OPA2350EA/2K5	DGK	8	MLA	330	12	5.2	3.3	1.6	12	12	Q1
OPA2350UA/2K5	D	8	MLA	330	12	6.9	5.4	2.0	8	12	Q1
OPA350EA/250	DGK	8	MLA	180	12	5.2	3.3	1.6	12	12	Q1
OPA350EA/2K5	DGK	8	MLA	330	12	5.2	3.3	1.6	12	12	Q1
OPA350UA/2K5	D	8	MLA	330	12	6.9	5.4	2.0	8	12	Q1
OPA4350EA/250	DBQ	16	TUA	177	12	6.7	5.4	2.1	8	12	Q1
OPA4350EA/2K5	DBQ	16	TUA	330	12	6.7	5.4	2.1	8	12	NONE
OPA4350UA/2K5	D	14	MLA	330	16	6.5	9.5	2.1	8	16	Q1

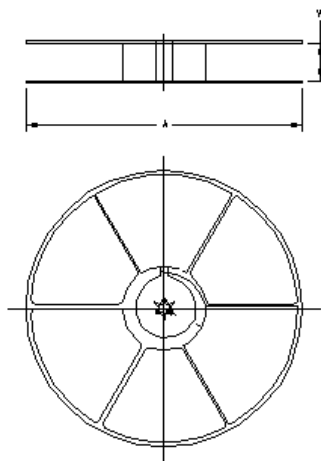

TAPE AND REEL BOX INFORMATION

Device	Package	Pins	Site	Length (mm)	Width (mm)	Height (mm)
OPA2350EA/250	DGK	8	MLA	0.0	0.0	0.0
OPA2350EA/2K5	DGK	8	MLA	346.0	346.0	29.0
OPA2350UA/2K5	D	8	MLA	346.0	346.0	29.0
OPA350EA/250	DGK	8	MLA	0.0	0.0	0.0
OPA350EA/2K5	DGK	8	MLA	346.0	346.0	29.0
OPA350UA/2K5	D	8	MLA	346.0	346.0	29.0
OPA4350EA/250	DBQ	16	TUA	187.0	187.0	25.6
OPA4350EA/2K5	DBQ	16	TUA	375.0	340.0	57.0
OPA4350UA/2K5	D	14	MLA	346.0	346.0	33.0

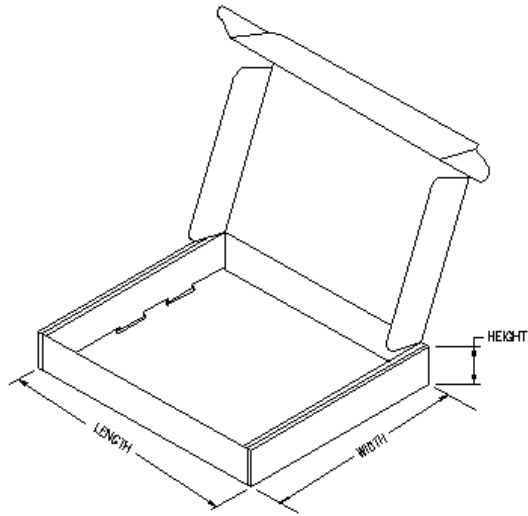

P (R-PDIP-T8)

PLASTIC DUAL-IN-LINE

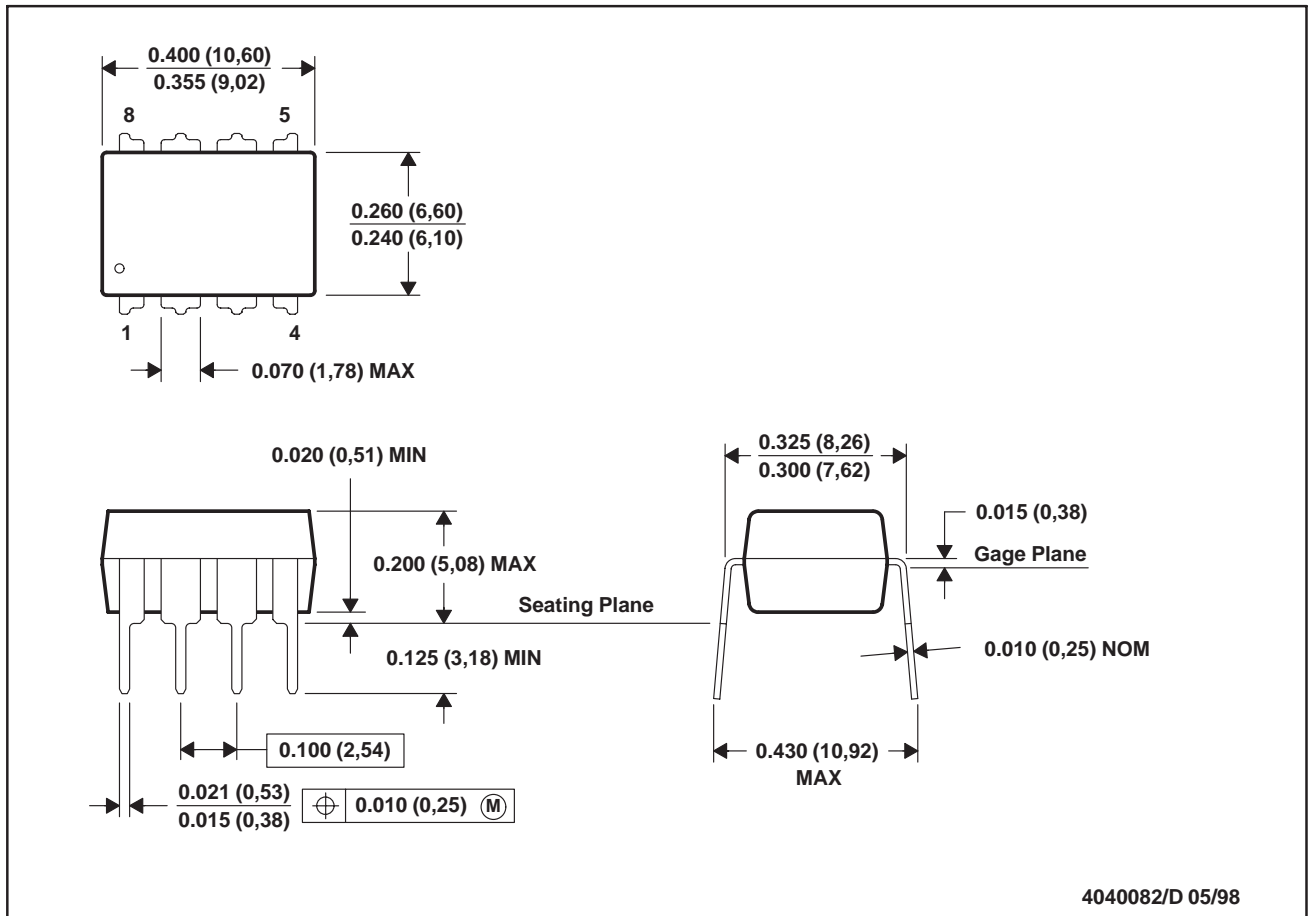

- NOTES: A. All linear dimensions are in inches (millimeters).
 B. This drawing is subject to change without notice.
 C. Falls within JEDEC MS-001

For the latest package information, go to http://www.ti.com/sc/docs/package/pkg_info.htm



POST OFFICE BOX 655303 • DALLAS, TEXAS 75265

DGK (S-PDSO-G8)

PLASTIC SMALL-OUTLINE PACKAGE

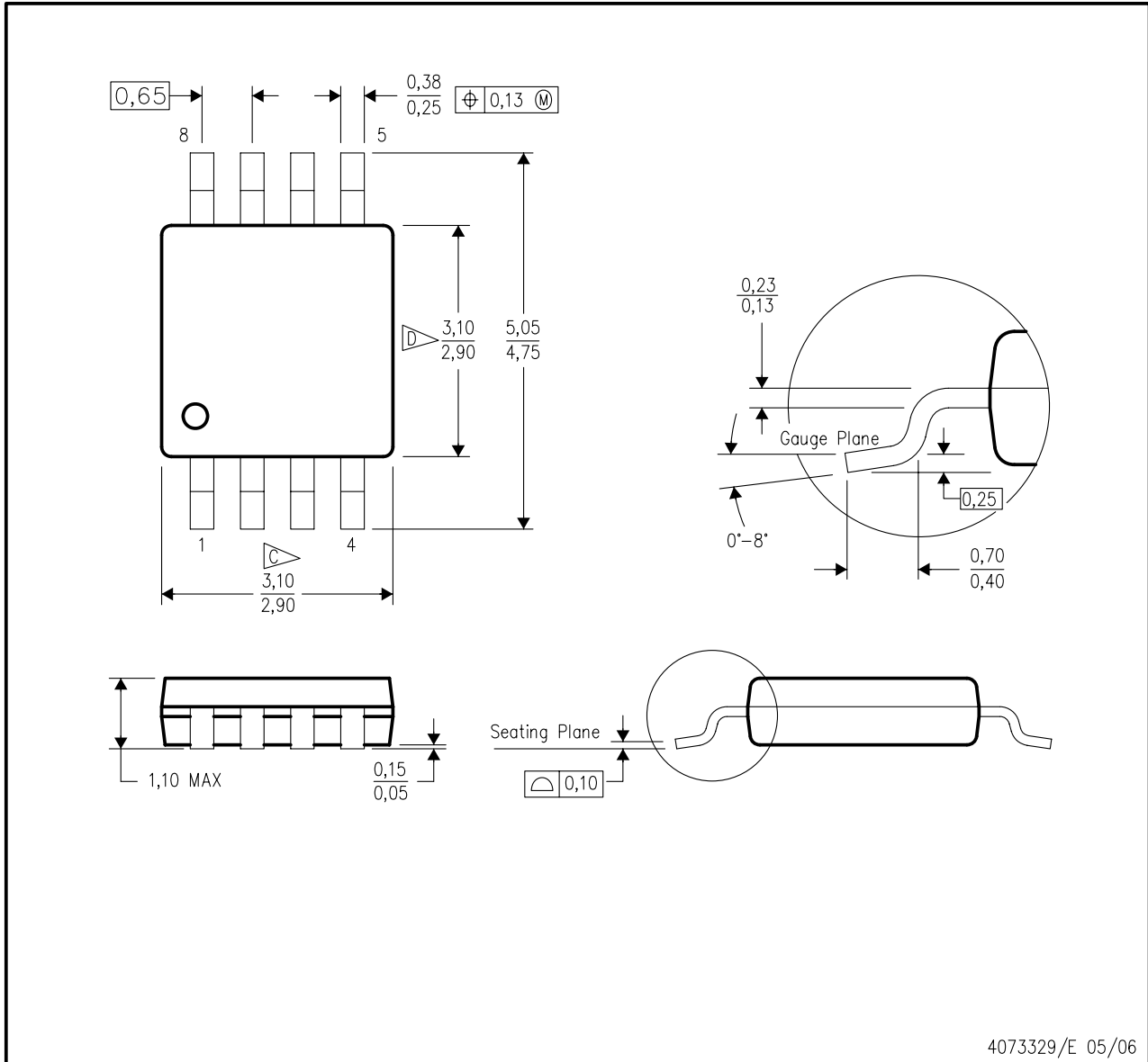

4073329/E 05/06

- NOTES:
- A. All linear dimensions are in millimeters.
 - B. This drawing is subject to change without notice.
 - C. Body length does not include mold flash, protrusions, or gate burrs. Mold flash, protrusions, or gate burrs shall not exceed 0.15 per end.
 - D. Body width does not include interlead flash. Interlead flash shall not exceed 0.50 per side.
 - E. Falls within JEDEC MO-187 variation AA, except interlead flash.

D (R-PDSO-G14)

PLASTIC SMALL-OUTLINE PACKAGE

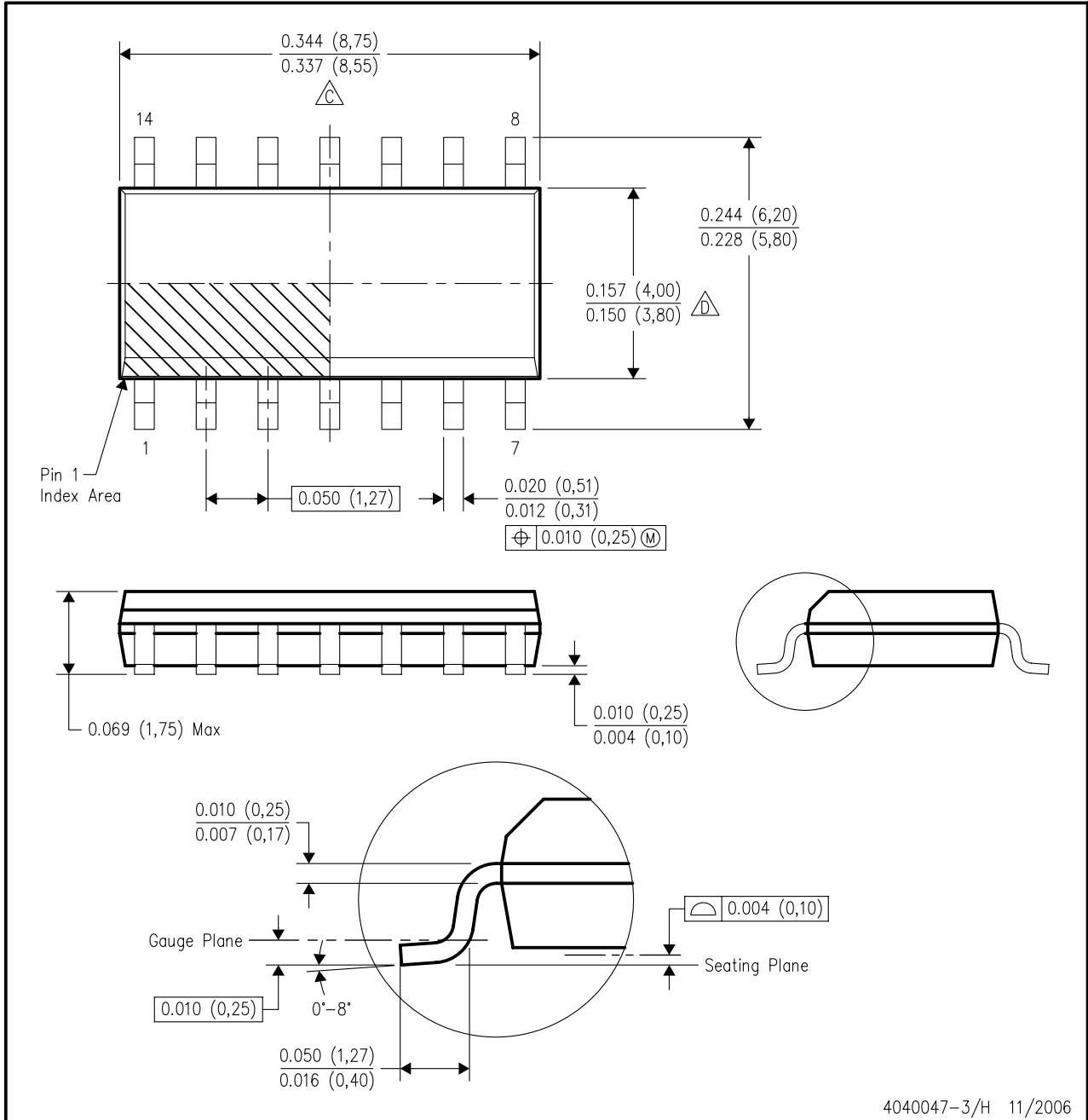

4040047-3/H 11/2006

- NOTES:
- A. All linear dimensions are in inches (millimeters).
 - B. This drawing is subject to change without notice.
 - C. Body length does not include mold flash, protrusions, or gate burrs. Mold flash, protrusions, or gate burrs shall not exceed $.006$ (0.15) per end.
 - D. Body width does not include interlead flash. Interlead flash shall not exceed $.017$ (0.43) per side.
 - E. Reference JEDEC MS-012 variation AB.

MECHANICAL DATA

D (R-PDSO-G8)

PLASTIC SMALL-OUTLINE PACKAGE

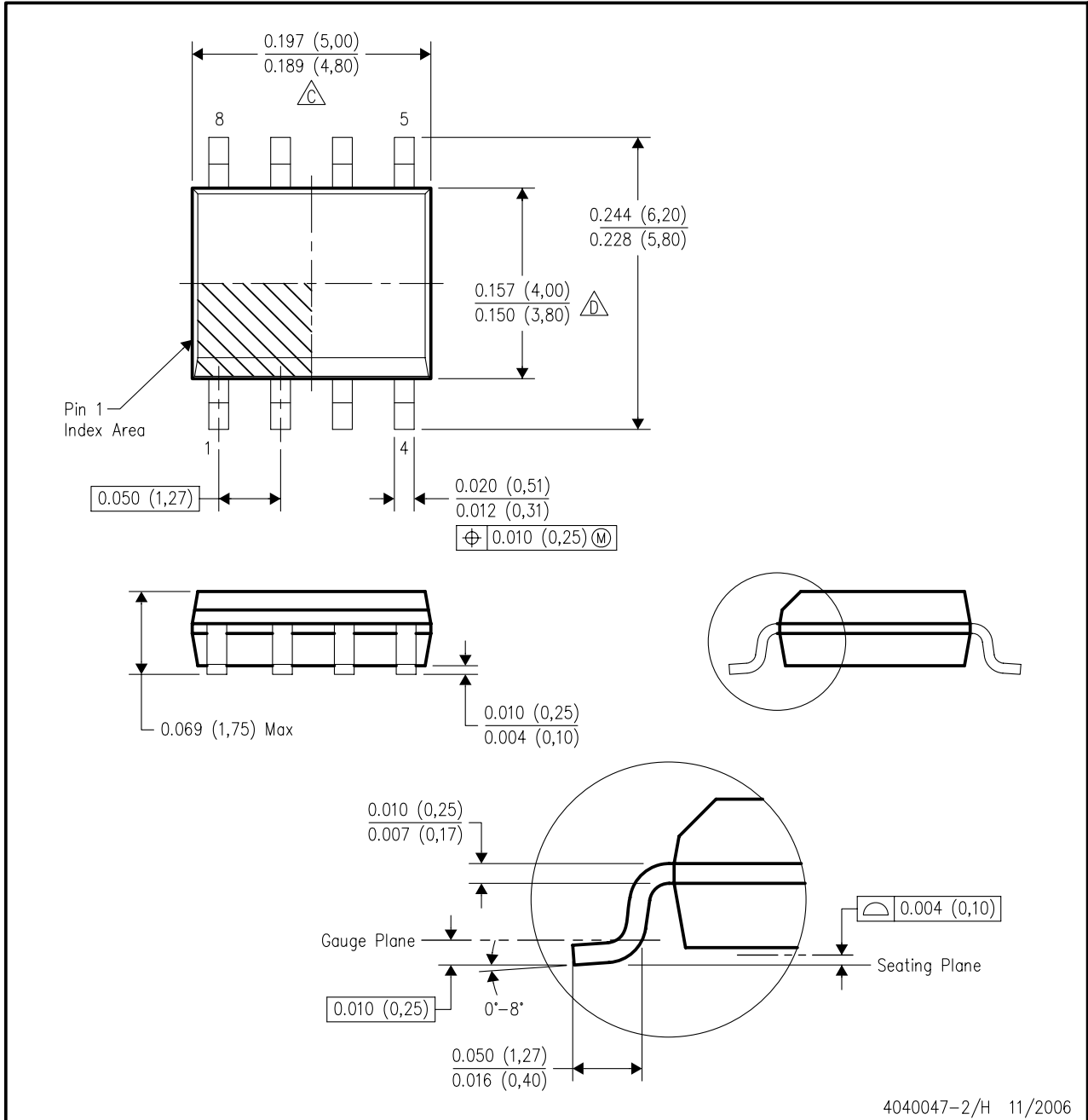

- NOTES:
- A. All linear dimensions are in inches (millimeters).
 - B. This drawing is subject to change without notice.
 - $\triangle C$ Body length does not include mold flash, protrusions, or gate burrs. Mold flash, protrusions, or gate burrs shall not exceed .006 (0,15) per end.
 - $\triangle D$ Body width does not include interlead flash. Interlead flash shall not exceed .017 (0,43) per side.
 - E. Reference JEDEC MS-012 variation AA.

MECHANICAL DATA

DBQ (R-PDSO-G16)

PLASTIC SMALL-OUTLINE PACKAGE

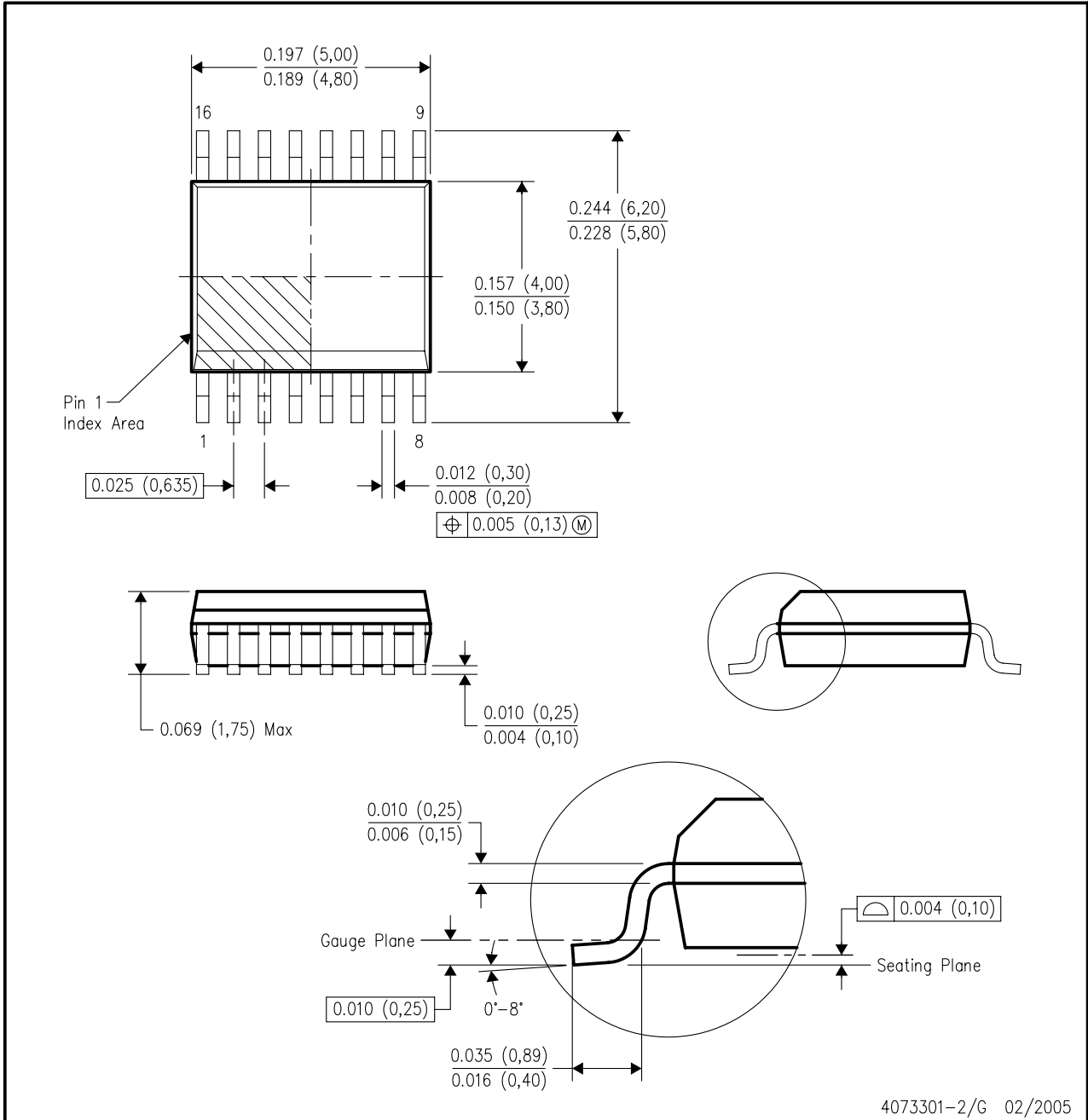

- NOTES:
- All linear dimensions are in inches (millimeters).
 - This drawing is subject to change without notice.
 - Body dimensions do not include mold flash or protrusion not to exceed 0.006 (0,15) per side.
 - Falls within JEDEC MO-137 variation AB.

IMPORTANT NOTICE

Texas Instruments Incorporated and its subsidiaries (TI) reserve the right to make corrections, modifications, enhancements, improvements, and other changes to its products and services at any time and to discontinue any product or service without notice. Customers should obtain the latest relevant information before placing orders and should verify that such information is current and complete. All products are sold subject to TI's terms and conditions of sale supplied at the time of order acknowledgment.

TI warrants performance of its hardware products to the specifications applicable at the time of sale in accordance with TI's standard warranty. Testing and other quality control techniques are used to the extent TI deems necessary to support this warranty. Except where mandated by government requirements, testing of all parameters of each product is not necessarily performed.

TI assumes no liability for applications assistance or customer product design. Customers are responsible for their products and applications using TI components. To minimize the risks associated with customer products and applications, customers should provide adequate design and operating safeguards.

TI does not warrant or represent that any license, either express or implied, is granted under any TI patent right, copyright, mask work right, or other TI intellectual property right relating to any combination, machine, or process in which TI products or services are used. Information published by TI regarding third-party products or services does not constitute a license from TI to use such products or services or a warranty or endorsement thereof. Use of such information may require a license from a third party under the patents or other intellectual property of the third party, or a license from TI under the patents or other intellectual property of TI.

Reproduction of TI information in TI data books or data sheets is permissible only if reproduction is without alteration and is accompanied by all associated warranties, conditions, limitations, and notices. Reproduction of this information with alteration is an unfair and deceptive business practice. TI is not responsible or liable for such altered documentation. Information of third parties may be subject to additional restrictions.

Resale of TI products or services with statements different from or beyond the parameters stated by TI for that product or service voids all express and any implied warranties for the associated TI product or service and is an unfair and deceptive business practice. TI is not responsible or liable for any such statements.

TI products are not authorized for use in safety-critical applications (such as life support) where a failure of the TI product would reasonably be expected to cause severe personal injury or death, unless officers of the parties have executed an agreement specifically governing such use. Buyers represent that they have all necessary expertise in the safety and regulatory ramifications of their applications, and acknowledge and agree that they are solely responsible for all legal, regulatory and safety-related requirements concerning their products and any use of TI products in such safety-critical applications, notwithstanding any applications-related information or support that may be provided by TI. Further, Buyers must fully indemnify TI and its representatives against any damages arising out of the use of TI products in such safety-critical applications.

TI products are neither designed nor intended for use in military/aerospace applications or environments unless the TI products are specifically designated by TI as military-grade or "enhanced plastic." Only products designated by TI as military-grade meet military specifications. Buyers acknowledge and agree that any such use of TI products which TI has not designated as military-grade is solely at the Buyer's risk, and that they are solely responsible for compliance with all legal and regulatory requirements in connection with such use.

TI products are neither designed nor intended for use in automotive applications or environments unless the specific TI products are designated by TI as compliant with ISO/TS 16949 requirements. Buyers acknowledge and agree that, if they use any non-designated products in automotive applications, TI will not be responsible for any failure to meet such requirements.

Following are URLs where you can obtain information on other Texas Instruments products and application solutions:

Products		Applications	
Amplifiers	amplifier.ti.com	Audio	www.ti.com/audio
Data Converters	dataconverter.ti.com	Automotive	www.ti.com/automotive
DSP	dsp.ti.com	Broadband	www.ti.com/broadband
Interface	interface.ti.com	Digital Control	www.ti.com/digitalcontrol
Logic	logic.ti.com	Military	www.ti.com/military
Power Mgmt	power.ti.com	Optical Networking	www.ti.com/opticalnetwork
Microcontrollers	microcontroller.ti.com	Security	www.ti.com/security
RFID	www.ti-rfid.com	Telephony	www.ti.com/telephony
Low Power Wireless	www.ti.com/lpw	Video & Imaging	www.ti.com/video
		Wireless	www.ti.com/wireless

Mailing Address: Texas Instruments, Post Office Box 655303, Dallas, Texas 75265
Copyright © 2007, Texas Instruments Incorporated