

1.8V, 7MHz, 90dB CMRR, SINGLE-SUPPLY, RAIL-TO-RAIL I/O OPERATIONAL AMPLIFIER

FEATURES

- 1.8V OPERATION
- *Micro*SIZE PACKAGES
- BANDWIDTH: 7MHz
- CMRR: 90dB (typical)
- SLEW RATE: 5V/ μ s
- LOW OFFSET: 500 μ V (max)
- QUIESCENT CURRENT: 750 μ A/Channel (max)
- SHUTDOWN MODE: < 1 μ A/Channel

APPLICATIONS

- SIGNAL CONDITIONING
- DATA ACQUISITION
- PROCESS CONTROL
- ACTIVE FILTERS
- TEST EQUIPMENT

DESCRIPTION

The OPA363 and OPA364 families are high-performance CMOS operational amplifiers optimized for very low voltage, single-supply operation. These miniature, low-cost amplifiers are designed to operate on single supplies from 1.8V (± 0.9 V) to 5.5V (± 2.75 V). Applications include sensor amplification and signal conditioning in battery-powered systems.

The OPA363 and OPA364 families offer excellent CMRR without the crossover associated with traditional complimentary input stages. This results in excellent performance for driving Analog-to-Digital (A/D) converters without degradation of differential linearity and THD. The input common-mode range includes both the negative and positive supplies. The output voltage swing is within 10mV of the rails.

The OPA363 family includes a shutdown mode. Under logic control, the amplifiers can be switched from normal operation to a standby current that is less than 1 μ A.

The single version is available in the *Micro*SIZE SOT23-5 (SOT23-6 for shutdown) and SO-8. The dual version is available in MSOP-8, MSOP-10, and SO-8 packages. Quad packages are available in TSSOP-14 and SO-14 packages. All versions are specified for operation from -40° C to $+125^{\circ}$ C.

	OPA363	OPA364	OPA2363	OPA2364	OPA4364
SOT23-5		x			
SOT23-6	x				
MSOP-8				x	
MSOP-10			x		
SO-8	x	x		x	
TSSOP-14					x
SO-14					x



Please be aware that an important notice concerning availability, standard warranty, and use in critical applications of Texas Instruments semiconductor products and disclaimers thereto appears at the end of this data sheet.

ABSOLUTE MAXIMUM RATINGS⁽¹⁾

Supply Voltage	+5.5V
Signal Input Terminals, Voltage ⁽²⁾	-0.5V to (V+) + 0.5V
Current ⁽²⁾	±10mA
Enable Input	(V-) - 0.5V to 5.5V
Output Short-Circuit ⁽³⁾	Continuous
Operating Temperature	-40°C to +150°C
Storage Temperature	-65°C to +150°C
Junction Temperature	+150°C
Lead Temperature (soldering, 10s)	+300°C

NOTES: (1) Stresses above these ratings may cause permanent damage. Exposure to absolute maximum conditions for extended periods may degrade device reliability. These are stress ratings only, and functional operation of the device at these or any other conditions beyond those specified is not implied. (2) Input terminals are diode-clamped to the power-supply rails. Input signals that can swing more than 0.5V beyond the supply rails should be current limited to 10mA or less. (3) Short-circuit to ground one amplifier per package.



ELECTROSTATIC DISCHARGE SENSITIVITY

This integrated circuit can be damaged by ESD. Texas Instruments recommends that all integrated circuits be handled with appropriate precautions. Failure to observe proper handling and installation procedures can cause damage.

ESD damage can range from subtle performance degradation to complete device failure. Precision integrated circuits may be more susceptible to damage because very small parametric changes could cause the device not to meet its published specifications.

PACKAGE/ORDERING INFORMATION

PRODUCT	PACKAGE-LEAD	PACKAGE DESIGNATOR ⁽¹⁾	SPECIFIED TEMPERATURE RANGE	PACKAGE MARKING	ORDERING NUMBER	TRANSPORT MEDIA, QUANTITY
OPA363I "	SOT23-6 "	DBV "	-40°C to +125°C "	A40 "	OPA363IDBVT OPA363IDBVR	Tape and Reel, 250 Tape and Reel, 3000
OPA363I "	SO-8 "	D "	-40°C to +125°C "	OPA363 "	OPA363ID OPA363IDR	Rails, 100 Tape and Reel, 2500
OPA2363I "	MSOP-10 "	DGS "	-40°C to +125°C "	BHK "	OPA2363IDGST OPA2363IDGSR	Tape and Reel, 250 Tape and Reel, 2500
OPA364I "	SOT23-5 "	DBV "	-40°C to +125°C "	A41 "	OPA364IDBVT OPA364IDBVR	Tape and Reel, 250 Tape and Reel, 3000
OPA364I "	SO-8 "	D "	-40°C to +125°C "	OPA364 "	OPA364ID OPA364IDR	Rails, 100 Tape and Reel, 2500
OPA2364I "	MSOP-8 "	DGK "	-40°C to +125°C "	BHL "	OPA2364IDGKT OPA2364IDGKR	Tape and Reel, 250 Tape and Reel, 2500
OPA2364I "	SO-8 "	D "	-40°C to +125°C "	OPA2364 "	OPA2364ID OPA2364IDR	Rails, 100 Tape and Reel, 2500
OPA363AI "	SOT23-6 "	DBV "	-40°C to +125°C "	A40 "	OPA363AIDBVT OPA363AIDBVR	Tape and Reel, 250 Tape and Reel, 3000
OPA363AI "	SO-8 "	D "	-40°C to +125°C "	OPA363A "	OPA363AID OPA363AIDR	Rails, 100 Tape and Reel, 2500
OPA2363AI "	MSOP-10 "	DGS "	-40°C to +125°C "	BHK "	OPA2363AIDGST OPA2363AIDGSR	Tape and Reel, 250 Tape and Reel, 2500
OPA364AI "	SOT23-5 "	DBV "	-40°C to +125°C "	A41 "	OPA364AIDBVT OPA364AIDBVR	Tape and Reel, 250 Tape and Reel, 3000
OPA364AI "	SO-8 "	D "	-40°C to +125°C "	OPA364A "	OPA364AID OPA364AIDR	Rails, 100 Tape and Reel, 2500
OPA2364AI "	SO-8 "	D "	-40°C to +125°C "	OPA2634A "	OPA2364AID OPA2364AIDR	Rails, 100 Tape and Reel, 2500
OPA2364AI "	MSOP-8 "	DGK "	-40°C to +125°C "	BHL "	OPA2364AIDGKT OPA2364AIDGKR	Tape and Reel, 250 Tape and Reel, 2500
OPA4364AI "	SO-14 "	D "	-40°C to +125°C "	OPA4364A "	OPA4364AID OPA4364AIDR	Rails, 58 Tape and Reel, 2500
OPA4364AI "	TSSOP-14 "	PW "	-40°C to +125°C "	OPA4364A "	OPA4364AIPWT OPA4364AIPWR	Tape and Reel, 250 Tape and Reel, 2500

NOTES: (1) For the most current specifications and package information, refer to our web site at www.ti.com.

PIN CONFIGURATIONS

Top View

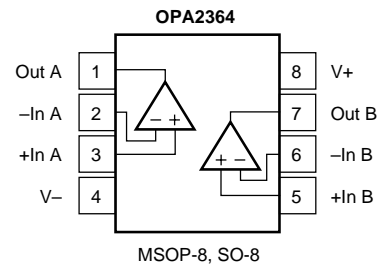
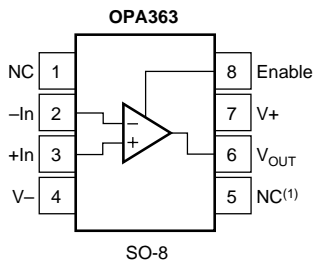
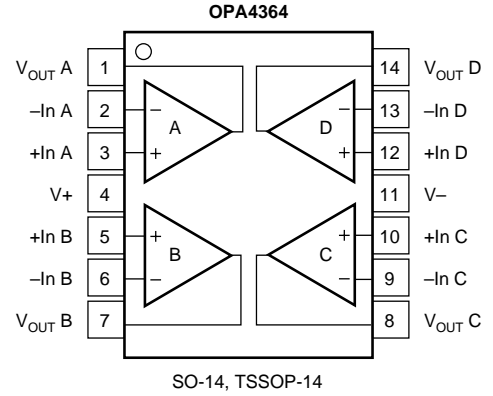
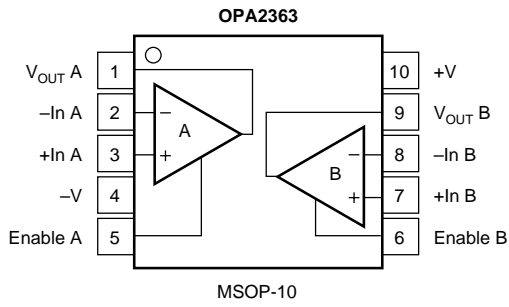
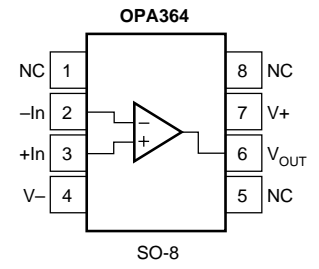
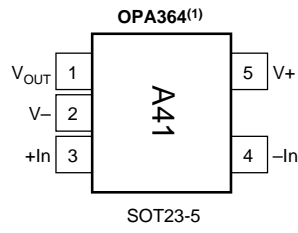
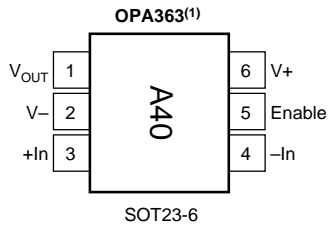

NOTE: (1) Orient according to marking.

NC = No Internal Connection.

TYPICAL CHARACTERISTICS

At $T_{CASE} = +25^{\circ}C$, $R_L = 10k\Omega$, and connected to $V_S/2$, $V_{OUT} = V_S/2$, $V_{CM} = V_S/2$, unless otherwise noted.

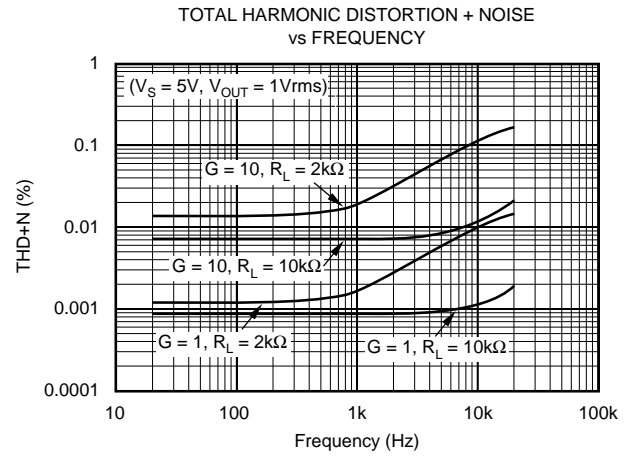
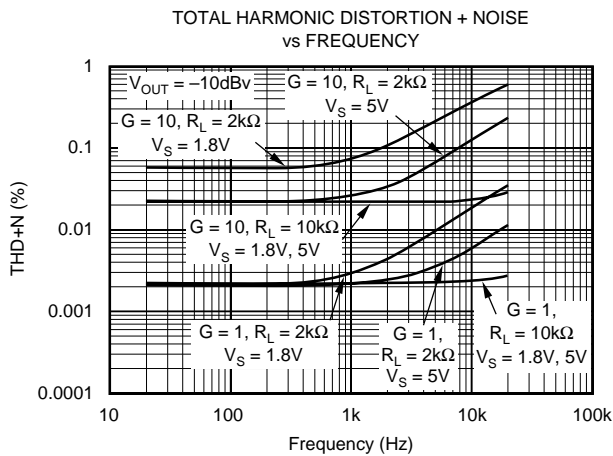
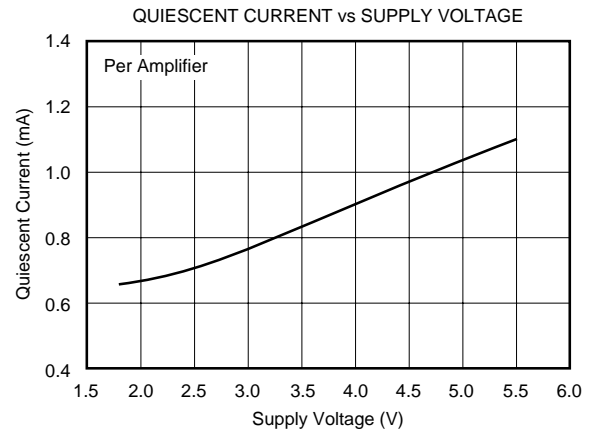
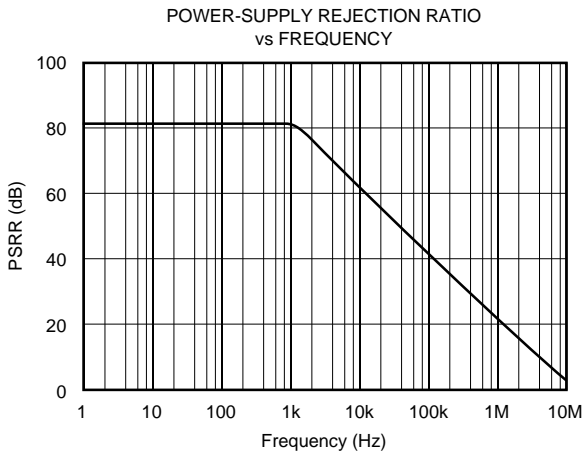
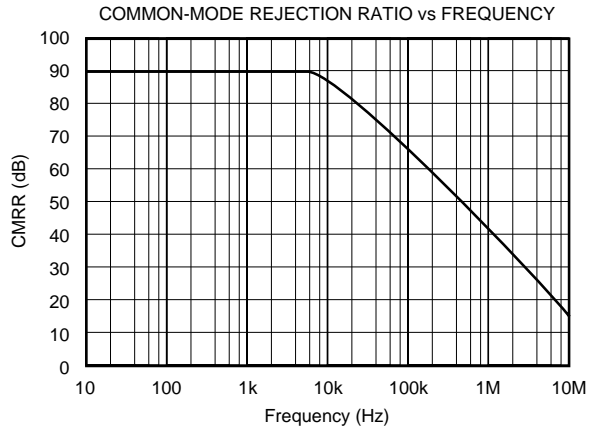
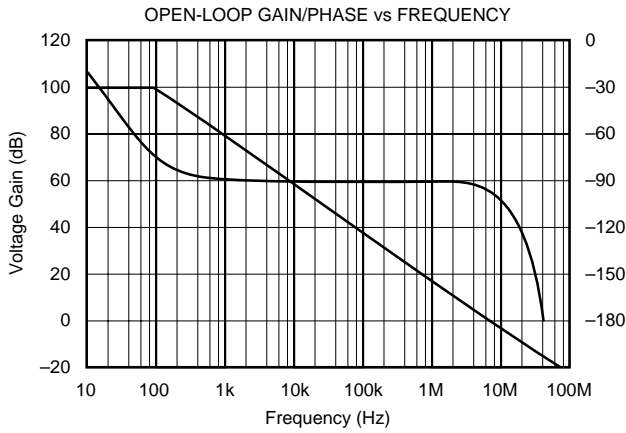

TYPICAL CHARACTERISTICS (Cont.)

At $T_{CASE} = +25^{\circ}C$, $R_L = 10k\Omega$, and connected to $V_S/2$, $V_{OUT} = V_S/2$, $V_{CM} = V_S/2$, unless otherwise noted.

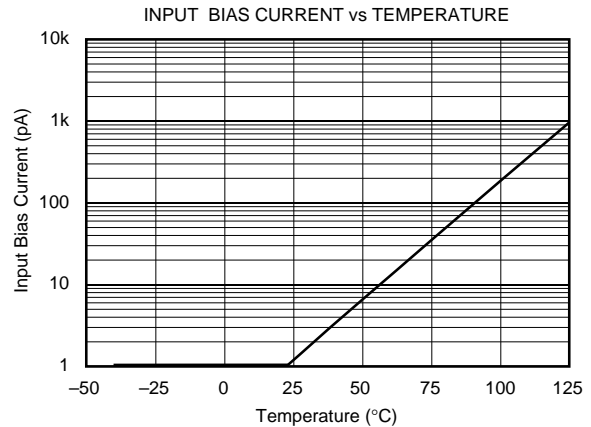
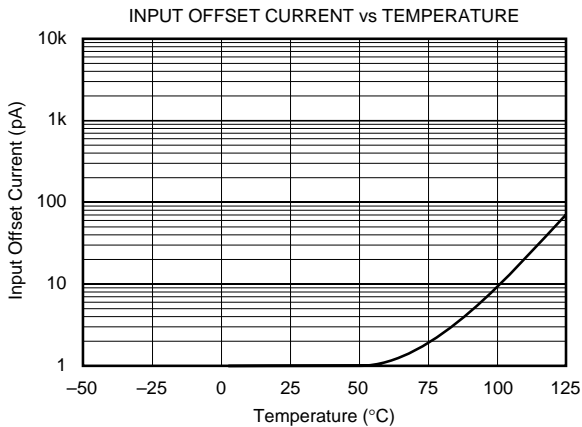
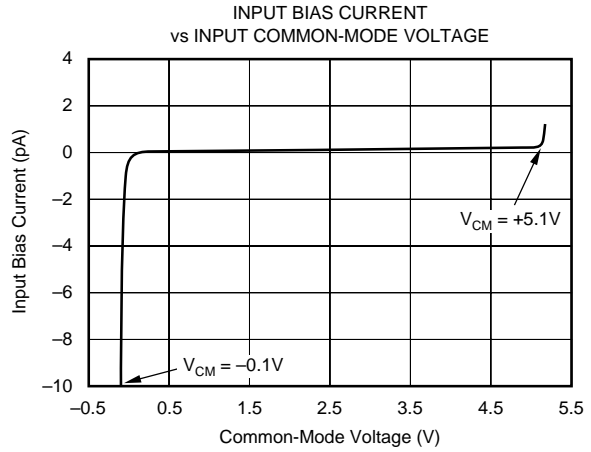
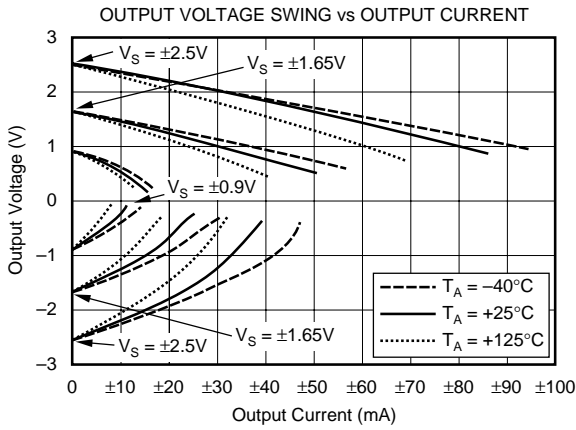
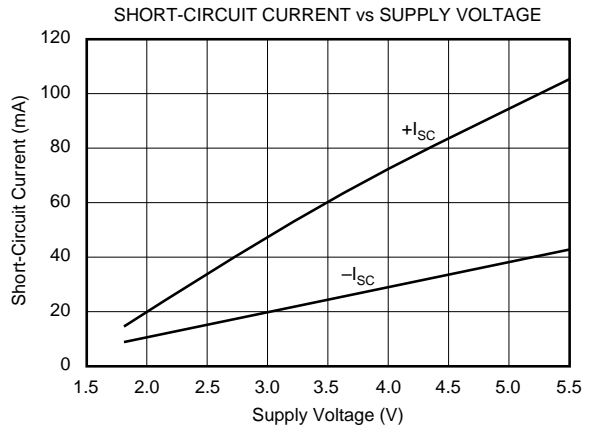
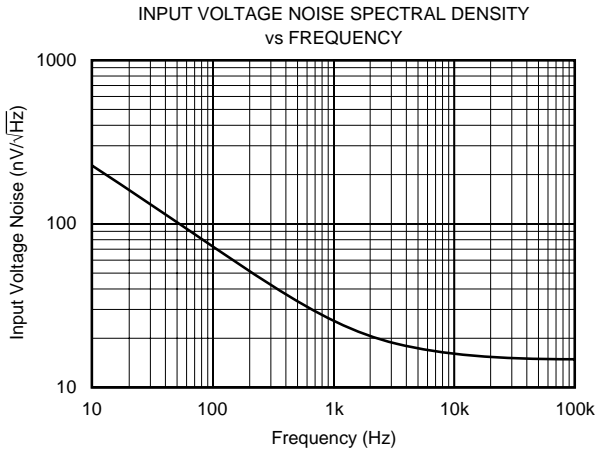

TYPICAL CHARACTERISTICS (Cont.)

At $T_{CASE} = +25^{\circ}C$, $R_L = 10k\Omega$, and connected to $V_S/2$, $V_{OUT} = V_S/2$, $V_{CM} = V_S/2$, unless otherwise noted.

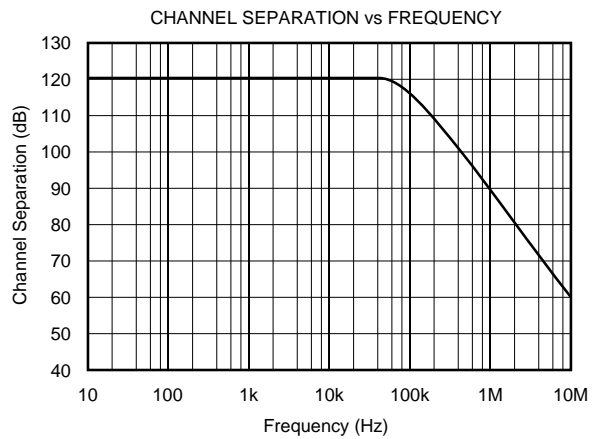
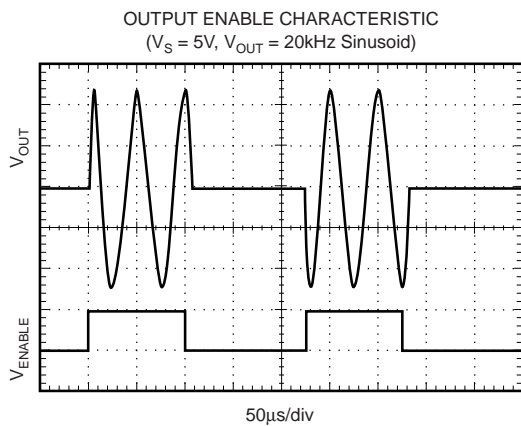
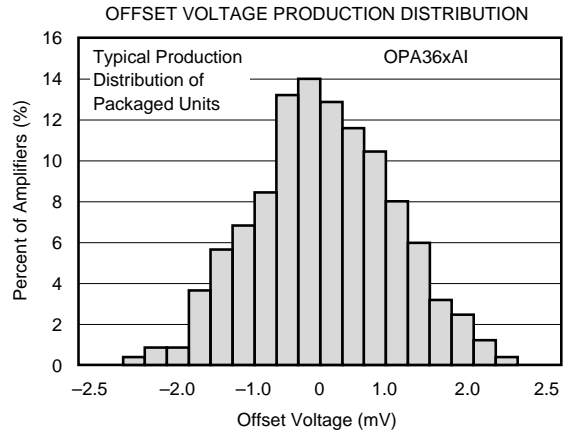
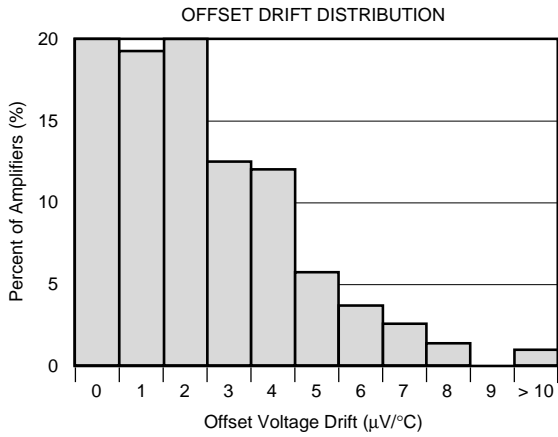
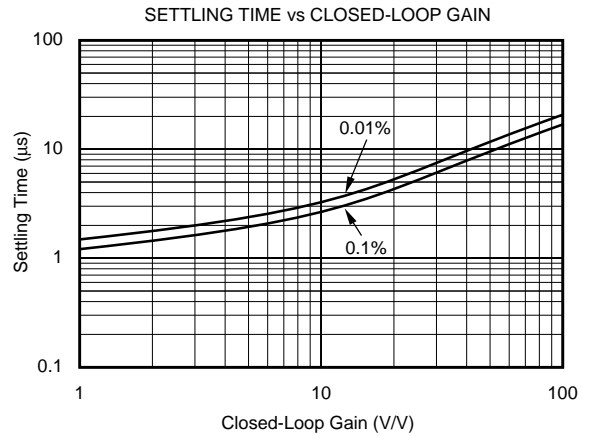
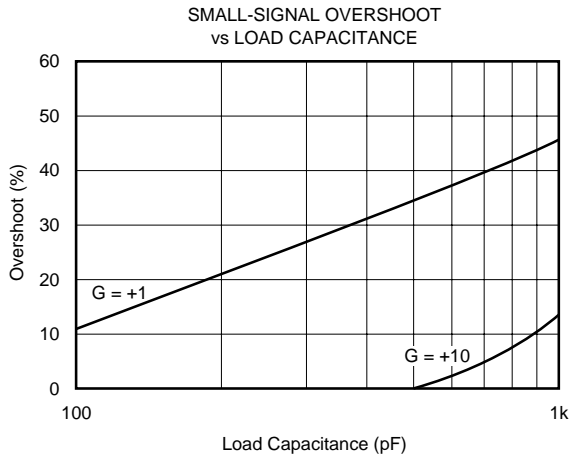

TYPICAL CHARACTERISTICS (Cont.)

At $T_{CASE} = +25^{\circ}C$, $R_L = 10k\Omega$, and connected to $V_S/2$, $V_{OUT} = V_S/2$, $V_{CM} = V_S/2$, unless otherwise noted.

SMALL-SIGNAL STEP RESPONSE
($C_L = 100pF$)

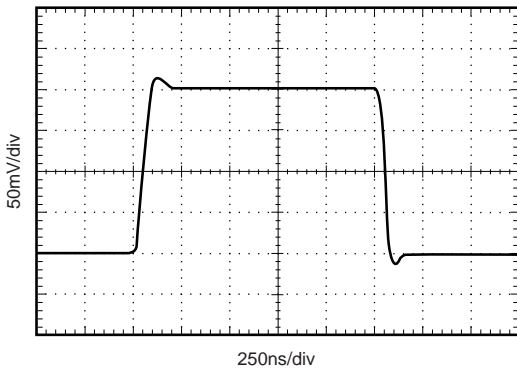

LARGE-SIGNAL STEP RESPONSE
($C_L = 100pF$)

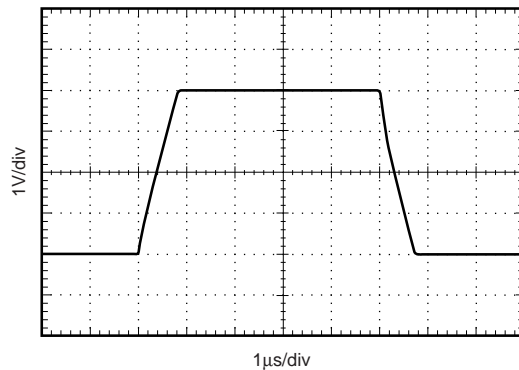

APPLICATIONS INFORMATION

The OPA363 and OPA364 series op amps are rail-to-rail operational amplifiers with excellent CMRR, low noise, low offset, and wide bandwidth on supply voltages as low as $\pm 0.9V$. The OPA363 features an additional pin for shutdown/enable function. These families do not exhibit phase reversal and are unity-gain stable. Specified over the industrial temperature range of $-40^{\circ}C$ to $+125^{\circ}C$, the OPA363 and OPA364 families offer precision performance for a wide range of applications.

RAIL-TO-RAIL INPUT

The OPA363 and OPA364 feature excellent rail-to-rail operation, with supply voltages as low as $\pm 0.9V$. The input common-mode voltage range of the OPA363 and OPA364 family extends 100mV beyond supply rails. The unique input topology of the OPA363 and OPA364 eliminates the input offset transition region typical of most rail-to-rail complementary stage operational amplifiers, allowing the OPA363 and OPA364 to provide superior common-mode performance over the entire common-mode input range, as seen in Figure 1. This feature prevents degradation of the differential linearity error and THD when driving A/D converters. A simplified schematic of the OPA363 and OPA364 is shown in Figure 2.

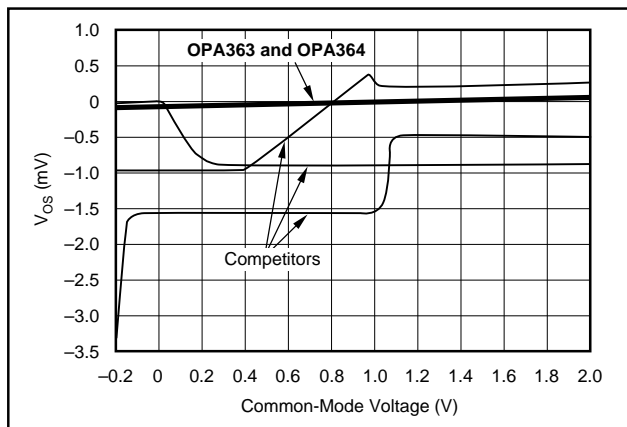

FIGURE 1. OPA363 and OPA364 have Linear Offset Over Entire Common-Mode Range.

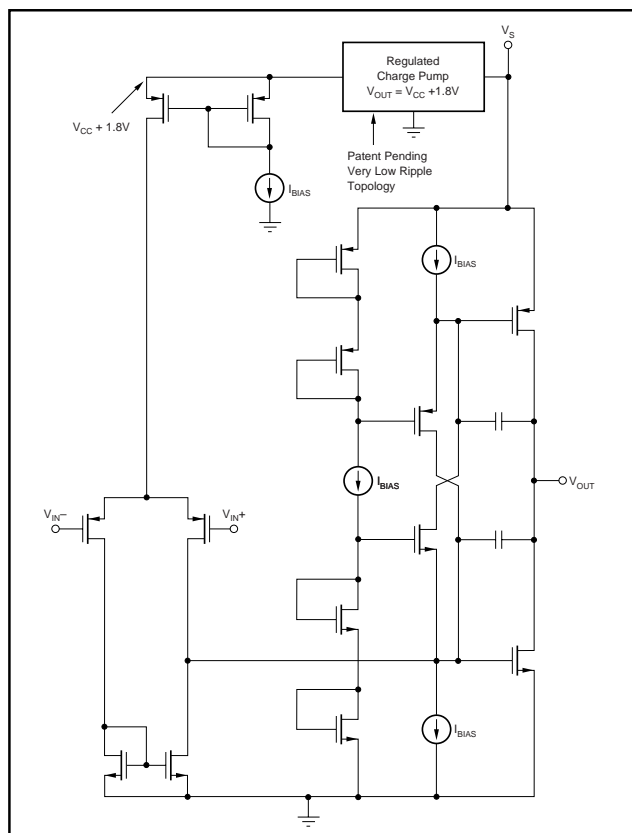

FIGURE 2. Simplified Schematic.

OPERATING VOLTAGE

The OPA363 and OPA364 series op amp parameters are fully specified from $+1.8V$ to $+5.5V$. Single $0.1\mu F$ bypass capacitors should be placed across supply pins and as close to the part as possible. Supply voltages higher than $5.5V$ (absolute maximum) may cause permanent damage to the amplifier. Many specifications apply from $-40^{\circ}C$ to $+125^{\circ}C$. Parameters that vary significantly with operating voltages or temperature are shown in the Typical Characteristics.

ENABLE FUNCTION

The shutdown (enable) function of the OPA363 is referenced to the negative supply voltage of the operational amplifier. A logic level HIGH enables the op amp. A valid logic HIGH is defined as voltage $> 75\%$ of the positive supply applied to the enable pin. The valid logic HIGH signal can be as much as 5.5V above the negative supply, independent of the positive supply voltage. A valid logic LOW is defined as $< 0.8V$ above the negative supply pin. If dual or split power supplies are used, care should be taken to ensure logic input signals are properly referred to the negative supply voltage. This pin should be connected to a valid high or low voltage or driven, not left open circuit.

The logic input is a high-impedance CMOS input. Dual op amps are provided separate logic inputs. For battery-operated applications, this feature may be used to greatly reduce the average current and extend battery life. The enable time is $20\mu s$; disable time is $1\mu s$. When disabled, the output assumes a high-impedance state. This allows the OPA363 to be operated as a “gated” amplifier, or to have its output multiplexed onto a common analog output bus.

CAPACITIVE LOAD

The OPA363 and OPA364 series op amps can drive a wide range of capacitive loads. However, all op amps under certain conditions may become unstable. Op amp configuration, gain, and load value are just a few of the factors to consider when determining stability. An op amp in unity-gain configuration is the most susceptible to the effects of capacitive load. The capacitive load reacts with the output resistance of the op amp to create a pole in the small-signal response, which degrades the phase margin.

In unity gain, the OPA363 and OPA364 series op amps perform well with a pure capacitive load up to approximately 1000pF. The ESR (Equivalent Series Resistance) of the loading capacitor may be sufficient to allow the OPA363 and OPA364 to directly drive very large capacitive loads ($> 1\mu F$). Increasing gain enhances the amplifier’s ability to drive more capacitance. See the typical characteristic “Small-Signal Overshoot vs Capacitive Load.”

One method of improving capacitive load drive in the unity-gain configuration is to insert a 10Ω to 20Ω resistor in series with the output, as shown in Figure 3. This significantly reduces ringing with large capacitive loads. However, if there is a resistive load in parallel with the capacitive load, it creates a voltage divider introducing a dc error at the output and slightly reduces output swing. This error may be insignificant. For instance, with $R_L = 10k\Omega$ and $R_S = 20\Omega$, there is only about a 0.2% error at the output.

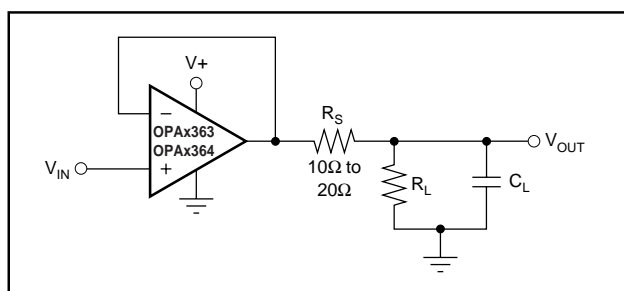

FIGURE 3. Improving Capacitive Load Drive.

INPUT AND ESD PROTECTION

All OPA363 and OPA364 pins are static protected with internal ESD protection diodes tied to the supplies. These diodes will provide overdrive protection if the current is externally limited to 10mA, as stated in the absolute maximum ratings and shown in Figure 4.

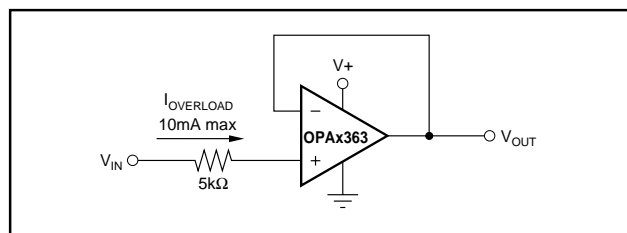

FIGURE 4. Input Current Protection.

ACHIEVING OUTPUT SWING TO THE OP AMP'S NEGATIVE RAIL

Some applications require an accurate output voltage swing from 0V to a positive full-scale voltage. A good single supply op amp may be able to swing within a few mV of single supply ground, but as the output is driven toward 0V, the output stage of the amplifier will prevent the output from reaching the negative supply rail of the amplifier.

The output of the OPA363 or OPA364 can be made to swing to ground, or slightly below, on a single supply power source. To do so requires use of another resistor and an additional, more negative power supply than the op amp’s negative supply. A pulldown resistor may be connected between the output and the additional negative supply to pull the output down below the value that the output would otherwise achieve as shown in Figure 5.

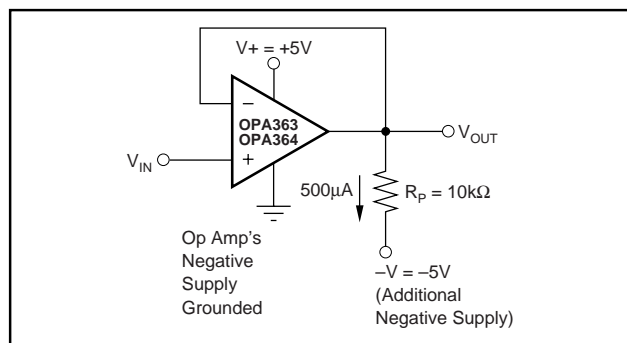

FIGURE 5. OPA363 and OPA364 Swing to Ground.

This technique will not work with all op amps. The output stage of the OPA363 and OPA364 allows the output voltage to be pulled below that of most op amps, if approximately $500\mu A$ is maintained through the output stage. To calculate the appropriate value load resistor and negative supply, $R_L = -V/500\mu A$. The OPA363 and OPA364 have been characterized to perform well under the described conditions, maintaining excellent accuracy down to 0V and as low as $-10mV$. Limiting and nonlinearity occur below $-10mV$, with linearity returning as the output is again driven above $-10mV$.

BUFFERED REFERENCE VOLTAGE

Many single-supply applications require a mid-supply reference voltage. The OPA363 and OPA364 offer excellent capacitive load drive capability, and can be configured to provide a 0.9V reference voltage, as can be seen in Figure 6. For appropriate loading considerations, see the “Capacitive Load” section.

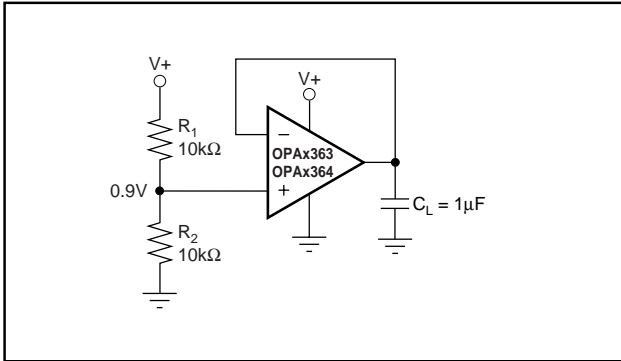

FIGURE 6. The OPA363 and OPA364 Provide a Stable Reference Voltage.

DIRECTLY DRIVING THE ADS8324 AND THE MSP430

The OPA363 and OPA364 series op amps are optimized for driving medium speed (up to 100kHz) sampling A/D converters. However, they also offer excellent performance for higher speed converters. The no crossover input stage of the OPA363 and OPA364 directly drive A/D converters without degradation of differential linearity and THD. They provide an effective means of buffering the A/D converters input capacitance and resulting charge injection while providing signal gain. Figure 7 and Figure 8 show the OPA363 and OPA364 configured to drive the ADS8324 and the 12-bit A/D converter on the MSP430.

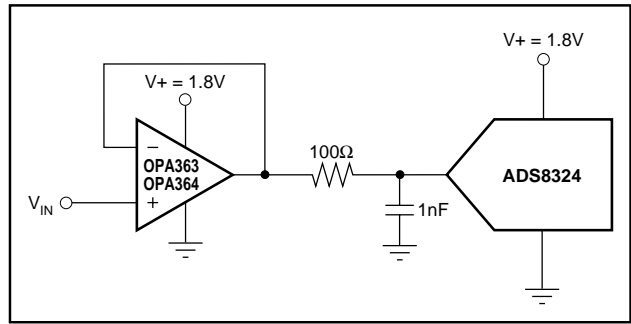

FIGURE 7. The OPA363 and OPA364 Directly Drive the ADS8324.

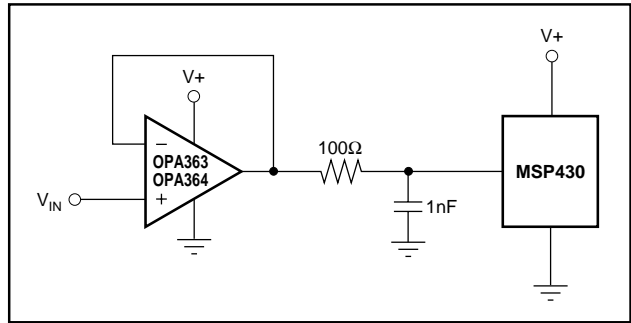

FIGURE 8. Driving the 12-Bit A/D Converter on the MSP430.

AUDIO APPLICATIONS

The OPA363 and OPA364 op amp family has linear offset voltage over the entire input common-mode range. Combined with low-noise, this feature makes the OPA363 and OPA364 suitable for audio applications. Single supply 1.8V operation allows the OPA2363 and OPA2364 to be optimal candidates for dual stereo-headphone drivers and microphone pre-amplifiers in portable stereo equipment, see Figures 9 and 10.

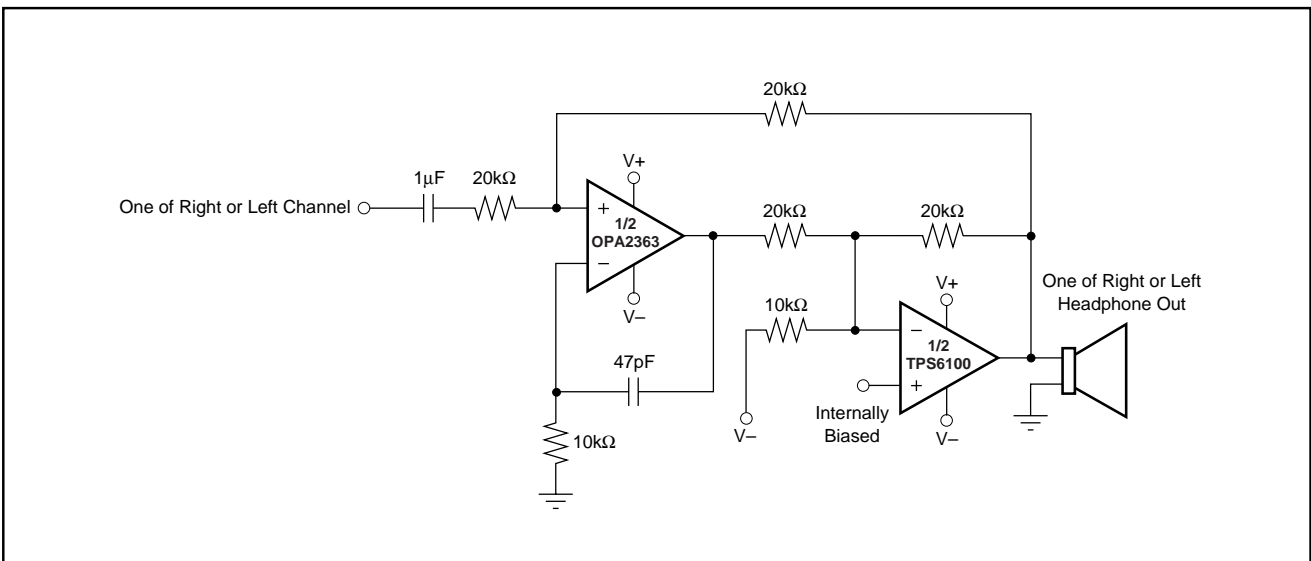

FIGURE 9. OPA2363 Configured as Half of a Dual Stereo Headphone Driver.

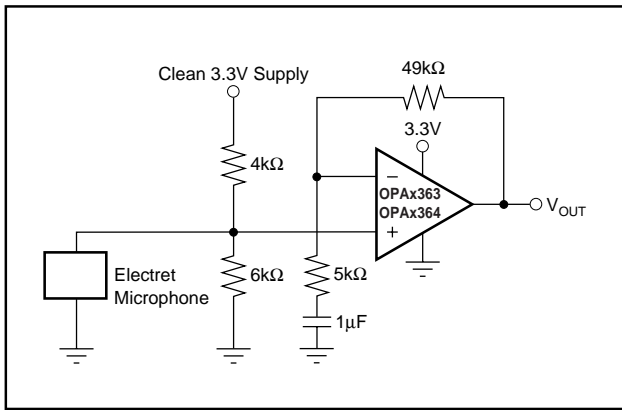

FIGURE 10. Microphone Preamplifier.

ACTIVE FILTERING

Low harmonic distortion and noise specifications plus high gain and slew rate make the OPA363 and OPA364 optimal candidates for active filtering. Figure 11 shows the OPA2363 configured as a low-distortion, 3rd-order GIC (General Immitance Converter) filter. Figure 12 shows the implementation of a Sallen-Key, 3-pole, low-pass Bessel filter.

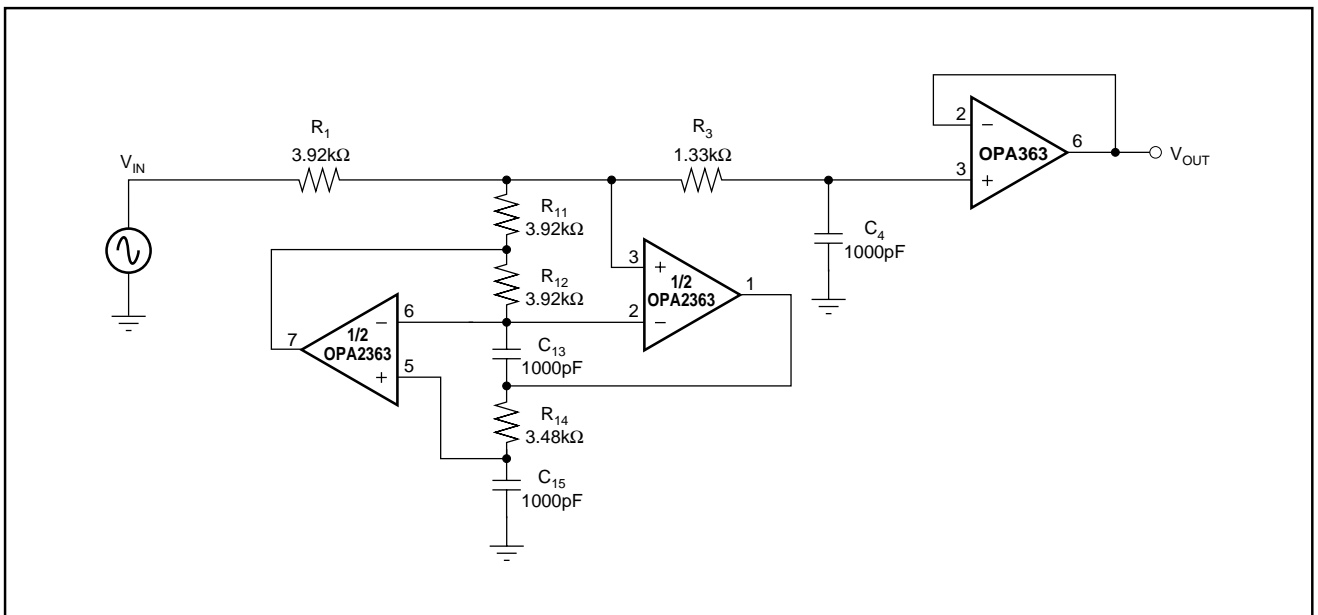

FIGURE 11. The OPA2363 as a 3rd-Order, 40kHz, Low-Pass GIC Filter.

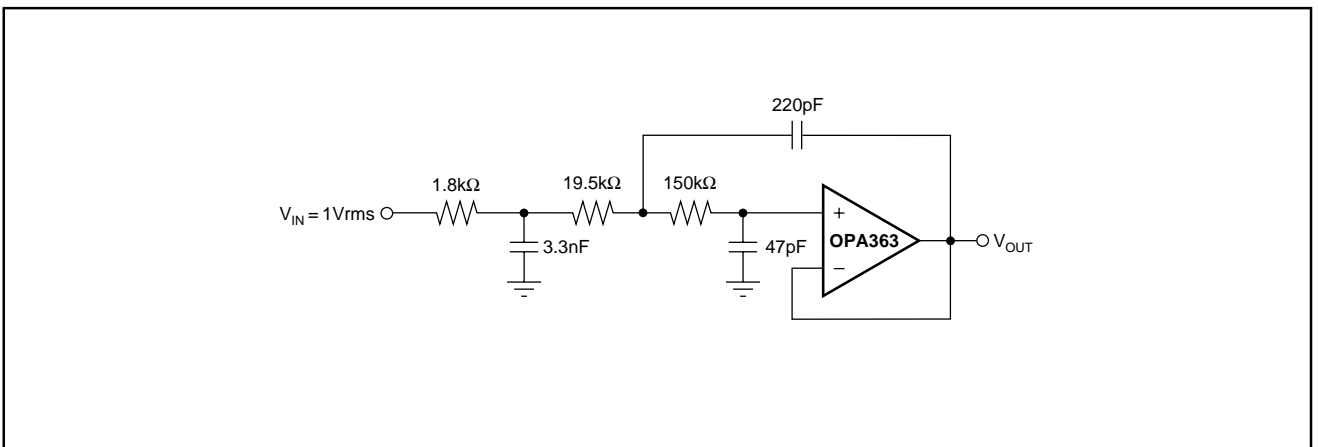

FIGURE 12. The OPA363 or OPA364 Configured as a 3-Pole, 20kHz, Sallen-Key Filter.

PACKAGING INFORMATION

Orderable Device	Status ⁽¹⁾	Package Type	Package Drawing	Pins	Package Qty	Eco Plan ⁽²⁾	Lead/Ball Finish	MSL Peak Temp ⁽³⁾
OPA2363AIDGSR	ACTIVE	MSOP	DGS	10	2500	Green (RoHS & no Sb/Br)	CU NIPDAU	Level-2-260C-1 YEAR
OPA2363AIDGSRG4	ACTIVE	MSOP	DGS	10	2500	Green (RoHS & no Sb/Br)	CU NIPDAU	Level-2-260C-1 YEAR
OPA2363AIDGST	ACTIVE	MSOP	DGS	10	250	Green (RoHS & no Sb/Br)	CU NIPDAU	Level-2-260C-1 YEAR
OPA2363AIDGSTG4	ACTIVE	MSOP	DGS	10	250	Green (RoHS & no Sb/Br)	CU NIPDAU	Level-2-260C-1 YEAR
OPA2363IDGSR	ACTIVE	MSOP	DGS	10	2500	Green (RoHS & no Sb/Br)	CU NIPDAU	Level-2-260C-1 YEAR
OPA2363IDGSRG4	ACTIVE	MSOP	DGS	10	2500	Green (RoHS & no Sb/Br)	CU NIPDAU	Level-2-260C-1 YEAR
OPA2363IDGST	ACTIVE	MSOP	DGS	10	250	Green (RoHS & no Sb/Br)	CU NIPDAU	Level-2-260C-1 YEAR
OPA2363IDGSTG4	ACTIVE	MSOP	DGS	10	250	Green (RoHS & no Sb/Br)	CU NIPDAU	Level-2-260C-1 YEAR
OPA2364AID	ACTIVE	SOIC	D	8	100	Green (RoHS & no Sb/Br)	CU NIPDAU	Level-2-260C-1 YEAR
OPA2364AIDG4	ACTIVE	SOIC	D	8	100	Green (RoHS & no Sb/Br)	CU NIPDAU	Level-2-260C-1 YEAR
OPA2364AIDGKR	ACTIVE	MSOP	DGK	8	2500	Green (RoHS & no Sb/Br)	CU NIPDAU	Level-2-260C-1 YEAR
OPA2364AIDGKRG4	ACTIVE	MSOP	DGK	8	2500	Green (RoHS & no Sb/Br)	CU NIPDAU	Level-2-260C-1 YEAR
OPA2364AIDGKT	ACTIVE	MSOP	DGK	8	250	Green (RoHS & no Sb/Br)	CU NIPDAU	Level-2-260C-1 YEAR
OPA2364AIDGKTG4	ACTIVE	MSOP	DGK	8	250	Green (RoHS & no Sb/Br)	CU NIPDAU	Level-2-260C-1 YEAR
OPA2364AIDR	ACTIVE	SOIC	D	8	2500	Green (RoHS & no Sb/Br)	CU NIPDAU	Level-2-260C-1 YEAR
OPA2364AIDRG4	ACTIVE	SOIC	D	8	2500	Green (RoHS & no Sb/Br)	CU NIPDAU	Level-2-260C-1 YEAR
OPA2364ID	ACTIVE	SOIC	D	8	100	Green (RoHS & no Sb/Br)	CU NIPDAU	Level-2-260C-1 YEAR
OPA2364IDG4	ACTIVE	SOIC	D	8	100	Green (RoHS & no Sb/Br)	CU NIPDAU	Level-2-260C-1 YEAR
OPA2364IDGKR	ACTIVE	MSOP	DGK	8	2500	Green (RoHS & no Sb/Br)	CU NIPDAU	Level-2-260C-1 YEAR
OPA2364IDGKRG4	ACTIVE	MSOP	DGK	8	2500	Green (RoHS & no Sb/Br)	CU NIPDAU	Level-2-260C-1 YEAR
OPA2364IDGKT	ACTIVE	MSOP	DGK	8	250	Green (RoHS & no Sb/Br)	CU NIPDAU	Level-2-260C-1 YEAR
OPA2364IDGKTG4	ACTIVE	MSOP	DGK	8	250	Green (RoHS & no Sb/Br)	CU NIPDAU	Level-2-260C-1 YEAR
OPA2364IDR	ACTIVE	SOIC	D	8	2500	Green (RoHS & no Sb/Br)	CU NIPDAU	Level-2-260C-1 YEAR
OPA2364IDRG4	ACTIVE	SOIC	D	8	2500	Green (RoHS & no Sb/Br)	CU NIPDAU	Level-2-260C-1 YEAR
OPA363AID	ACTIVE	SOIC	D	8	100	Green (RoHS & no Sb/Br)	CU NIPDAU	Level-2-260C-1 YEAR

Orderable Device	Status ⁽¹⁾	Package Type	Package Drawing	Pins	Package Qty	Eco Plan ⁽²⁾	Lead/Ball Finish	MSL Peak Temp ⁽³⁾
OPA363AIDBVR	ACTIVE	SOT-23	DBV	6	3000	Green (RoHS & no Sb/Br)	CU NIPDAU	Level-2-260C-1 YEAR
OPA363AIDBVRG4	ACTIVE	SOT-23	DBV	6	3000	Green (RoHS & no Sb/Br)	CU NIPDAU	Level-2-260C-1 YEAR
OPA363AIDBVT	ACTIVE	SOT-23	DBV	6	250	Green (RoHS & no Sb/Br)	CU NIPDAU	Level-2-260C-1 YEAR
OPA363AIDBVTG4	ACTIVE	SOT-23	DBV	6	250	Green (RoHS & no Sb/Br)	CU NIPDAU	Level-2-260C-1 YEAR
OPA363AIDG4	ACTIVE	SOIC	D	8	100	Green (RoHS & no Sb/Br)	CU NIPDAU	Level-2-260C-1 YEAR
OPA363AIDR	ACTIVE	SOIC	D	8	2500	Green (RoHS & no Sb/Br)	CU NIPDAU	Level-2-260C-1 YEAR
OPA363AIDRG4	ACTIVE	SOIC	D	8	2500	Green (RoHS & no Sb/Br)	CU NIPDAU	Level-2-260C-1 YEAR
OPA363ID	ACTIVE	SOIC	D	8	100	Green (RoHS & no Sb/Br)	CU NIPDAU	Level-2-260C-1 YEAR
OPA363IDBVR	ACTIVE	SOT-23	DBV	6	3000	Green (RoHS & no Sb/Br)	CU NIPDAU	Level-2-260C-1 YEAR
OPA363IDBVRG4	ACTIVE	SOT-23	DBV	6	3000	Green (RoHS & no Sb/Br)	CU NIPDAU	Level-2-260C-1 YEAR
OPA363IDBVT	ACTIVE	SOT-23	DBV	6	250	Green (RoHS & no Sb/Br)	CU NIPDAU	Level-2-260C-1 YEAR
OPA363IDBVTG4	ACTIVE	SOT-23	DBV	6	250	Green (RoHS & no Sb/Br)	CU NIPDAU	Level-2-260C-1 YEAR
OPA363IDG4	ACTIVE	SOIC	D	8	100	Green (RoHS & no Sb/Br)	CU NIPDAU	Level-2-260C-1 YEAR
OPA363IDR	ACTIVE	SOIC	D	8	2500	Green (RoHS & no Sb/Br)	CU NIPDAU	Level-2-260C-1 YEAR
OPA363IDRG4	ACTIVE	SOIC	D	8	2500	Green (RoHS & no Sb/Br)	CU NIPDAU	Level-2-260C-1 YEAR
OPA364AID	ACTIVE	SOIC	D	8	100	Green (RoHS & no Sb/Br)	CU NIPDAU	Level-2-260C-1 YEAR
OPA364AIDBVR	ACTIVE	SOT-23	DBV	5	3000	Green (RoHS & no Sb/Br)	CU NIPDAU	Level-2-260C-1 YEAR
OPA364AIDBVRG4	ACTIVE	SOT-23	DBV	5	3000	Green (RoHS & no Sb/Br)	CU NIPDAU	Level-2-260C-1 YEAR
OPA364AIDBVT	ACTIVE	SOT-23	DBV	5	250	Green (RoHS & no Sb/Br)	CU NIPDAU	Level-2-260C-1 YEAR
OPA364AIDBVTG4	ACTIVE	SOT-23	DBV	5	250	Green (RoHS & no Sb/Br)	CU NIPDAU	Level-2-260C-1 YEAR
OPA364AIDG4	ACTIVE	SOIC	D	8	100	Green (RoHS & no Sb/Br)	CU NIPDAU	Level-2-260C-1 YEAR
OPA364AIDR	ACTIVE	SOIC	D	8	2500	Green (RoHS & no Sb/Br)	CU NIPDAU	Level-2-260C-1 YEAR
OPA364AIDRG4	ACTIVE	SOIC	D	8	2500	Green (RoHS & no Sb/Br)	CU NIPDAU	Level-2-260C-1 YEAR
OPA364ID	ACTIVE	SOIC	D	8	100	Green (RoHS & no Sb/Br)	CU NIPDAU	Level-2-260C-1 YEAR
OPA364IDBVR	ACTIVE	SOT-23	DBV	5	3000	Green (RoHS & no Sb/Br)	CU NIPDAU	Level-2-260C-1 YEAR
OPA364IDBVRG4	ACTIVE	SOT-23	DBV	5	3000	Green (RoHS & no Sb/Br)	CU NIPDAU	Level-2-260C-1 YEAR

Orderable Device	Status ⁽¹⁾	Package Type	Package Drawing	Pins	Package Qty	Eco Plan ⁽²⁾	Lead/Ball Finish	MSL Peak Temp ⁽³⁾
OPA364IDBVT	ACTIVE	SOT-23	DBV	5	250	Green (RoHS & no Sb/Br)	CU NIPDAU	Level-2-260C-1 YEAR
OPA364IDBVTG4	ACTIVE	SOT-23	DBV	5	250	Green (RoHS & no Sb/Br)	CU NIPDAU	Level-2-260C-1 YEAR
OPA364IDG4	ACTIVE	SOIC	D	8	100	Green (RoHS & no Sb/Br)	CU NIPDAU	Level-2-260C-1 YEAR
OPA364IDR	ACTIVE	SOIC	D	8	2500	Green (RoHS & no Sb/Br)	CU NIPDAU	Level-2-260C-1 YEAR
OPA364IDRG4	ACTIVE	SOIC	D	8	2500	Green (RoHS & no Sb/Br)	CU NIPDAU	Level-2-260C-1 YEAR
OPA4364AID	ACTIVE	SOIC	D	14	58	Green (RoHS & no Sb/Br)	CU NIPDAU	Level-2-260C-1 YEAR
OPA4364AIDG4	ACTIVE	SOIC	D	14	58	Green (RoHS & no Sb/Br)	CU NIPDAU	Level-2-260C-1 YEAR
OPA4364AIDR	ACTIVE	SOIC	D	14	2500	Green (RoHS & no Sb/Br)	CU NIPDAU	Level-2-260C-1 YEAR
OPA4364AIDRG4	ACTIVE	SOIC	D	14	2500	Green (RoHS & no Sb/Br)	CU NIPDAU	Level-2-260C-1 YEAR
OPA4364AIPWR	ACTIVE	TSSOP	PW	14	2500	Green (RoHS & no Sb/Br)	CU NIPDAU	Level-2-260C-1 YEAR
OPA4364AIPWRG4	ACTIVE	TSSOP	PW	14	2500	Green (RoHS & no Sb/Br)	CU NIPDAU	Level-2-260C-1 YEAR
OPA4364AIPWT	ACTIVE	TSSOP	PW	14	250	Green (RoHS & no Sb/Br)	CU NIPDAU	Level-2-260C-1 YEAR
OPA4364AIPWTG4	ACTIVE	TSSOP	PW	14	250	Green (RoHS & no Sb/Br)	CU NIPDAU	Level-2-260C-1 YEAR

⁽¹⁾ The marketing status values are defined as follows:

ACTIVE: Product device recommended for new designs.

LIFEBUY: TI has announced that the device will be discontinued, and a lifetime-buy period is in effect.

NRND: Not recommended for new designs. Device is in production to support existing customers, but TI does not recommend using this part in a new design.

PREVIEW: Device has been announced but is not in production. Samples may or may not be available.

OBSELETE: TI has discontinued the production of the device.

⁽²⁾ Eco Plan - The planned eco-friendly classification: Pb-Free (RoHS), Pb-Free (RoHS Exempt), or Green (RoHS & no Sb/Br) - please check <http://www.ti.com/productcontent> for the latest availability information and additional product content details.

TBD: The Pb-Free/Green conversion plan has not been defined.

Pb-Free (RoHS): TI's terms "Lead-Free" or "Pb-Free" mean semiconductor products that are compatible with the current RoHS requirements for all 6 substances, including the requirement that lead not exceed 0.1% by weight in homogeneous materials. Where designed to be soldered at high temperatures, TI Pb-Free products are suitable for use in specified lead-free processes.

Pb-Free (RoHS Exempt): This component has a RoHS exemption for either 1) lead-based flip-chip solder bumps used between the die and package, or 2) lead-based die adhesive used between the die and leadframe. The component is otherwise considered Pb-Free (RoHS compatible) as defined above.

Green (RoHS & no Sb/Br): TI defines "Green" to mean Pb-Free (RoHS compatible), and free of Bromine (Br) and Antimony (Sb) based flame retardants (Br or Sb do not exceed 0.1% by weight in homogeneous material)

⁽³⁾ MSL, Peak Temp. -- The Moisture Sensitivity Level rating according to the JEDEC industry standard classifications, and peak solder temperature.

Important Information and Disclaimer:The information provided on this page represents TI's knowledge and belief as of the date that it is provided. TI bases its knowledge and belief on information provided by third parties, and makes no representation or warranty as to the accuracy of such information. Efforts are underway to better integrate information from third parties. TI has taken and continues to take reasonable steps to provide representative and accurate information but may not have conducted destructive testing or chemical analysis on incoming materials and chemicals. TI and TI suppliers consider certain information to be proprietary, and thus CAS numbers and other limited information may not be available for release.

In no event shall TI's liability arising out of such information exceed the total purchase price of the TI part(s) at issue in this document sold by TI to Customer on an annual basis.

MECHANICAL DATA

DBV (R-PDSO-G5)

PLASTIC SMALL-OUTLINE PACKAGE

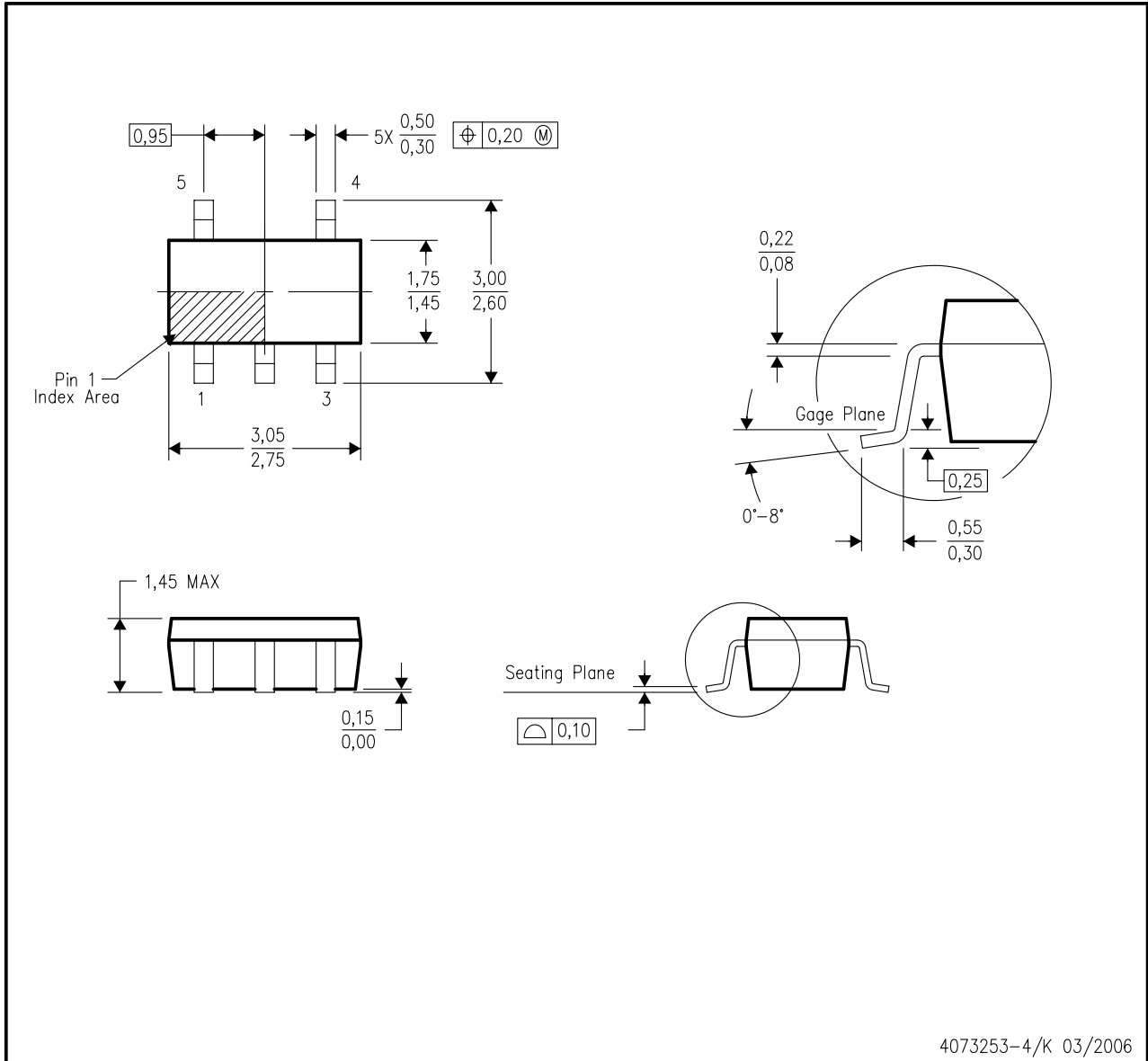

- NOTES:
- A. All linear dimensions are in millimeters.
 - B. This drawing is subject to change without notice.
 - C. Body dimensions do not include mold flash or protrusion. Mold flash and protrusion shall not exceed 0.15 per side.
 - D. Falls within JEDEC MO-178 Variation AA.

MECHANICAL DATA

DBV (R-PDSO-G6)

PLASTIC SMALL-OUTLINE PACKAGE

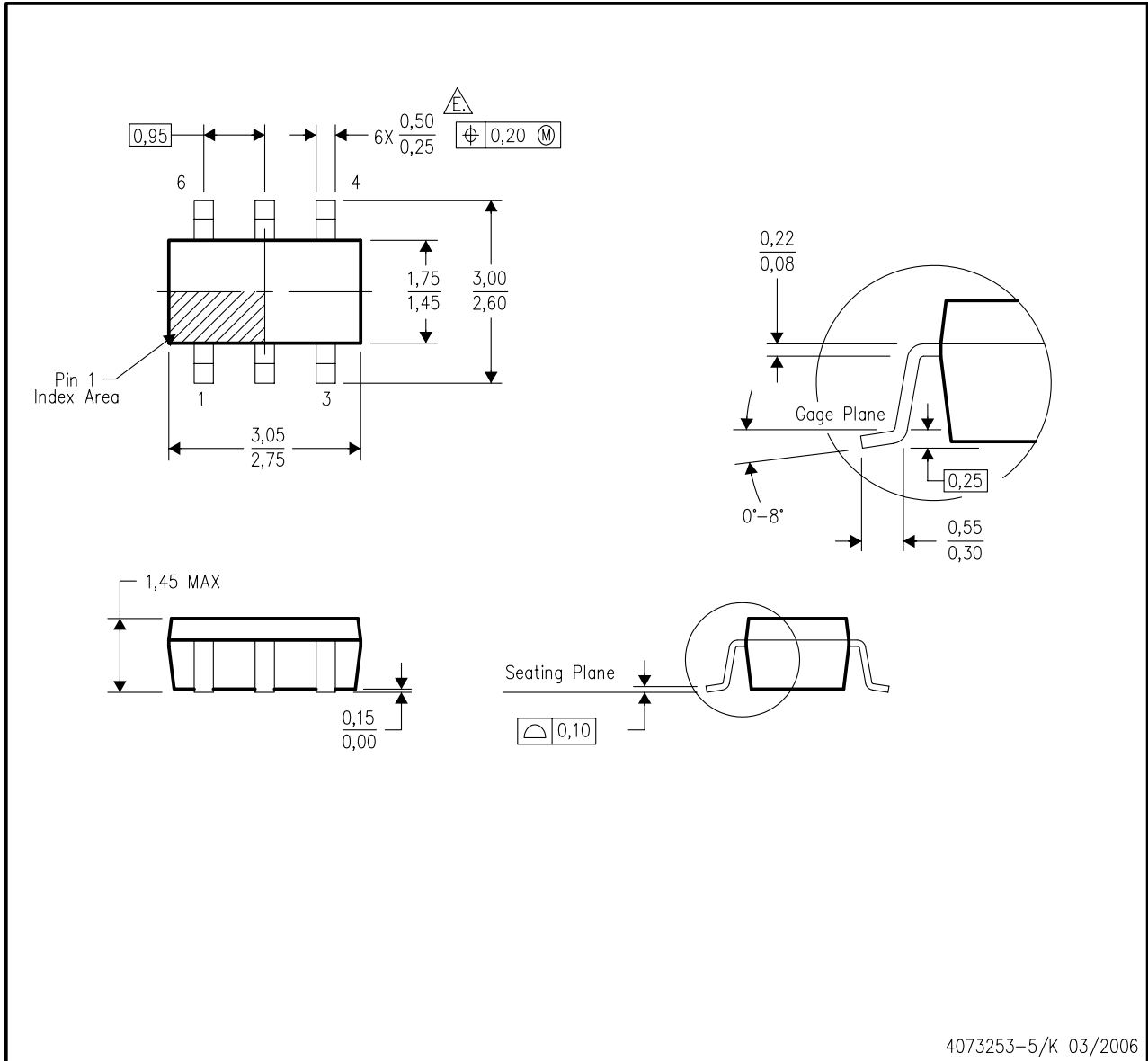

- NOTES:
- A. All linear dimensions are in millimeters.
 - B. This drawing is subject to change without notice.
 - C. Body dimensions do not include mold flash or protrusion. Mold flash and protrusion shall not exceed 0.15 per side.
 - D. Leads 1,2,3 may be wider than leads 4,5,6 for package orientation.
- \triangle Falls within JEDEC MO-178 Variation AB, except minimum lead width.

DGK (S-PDSO-G8)

PLASTIC SMALL-OUTLINE PACKAGE

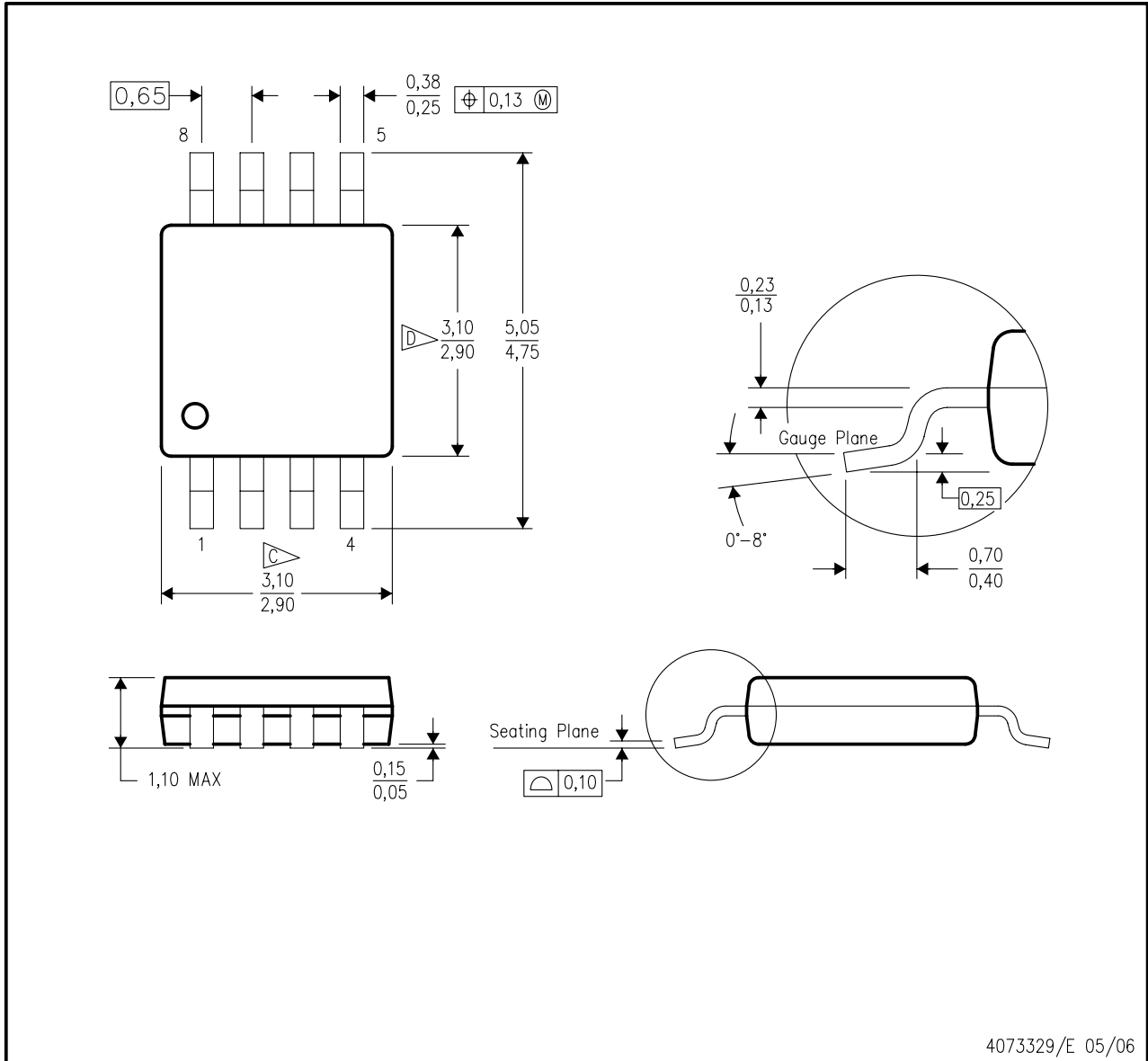

- NOTES:
- A. All linear dimensions are in millimeters.
 - B. This drawing is subject to change without notice.
 - C. Body length does not include mold flash, protrusions, or gate burrs. Mold flash, protrusions, or gate burrs shall not exceed 0.15 per end.
 - D. Body width does not include interlead flash. Interlead flash shall not exceed 0.50 per side.
 - E. Falls within JEDEC MO-187 variation AA, except interlead flash.

DGS (S-PDSO-G10)

PLASTIC SMALL-OUTLINE PACKAGE

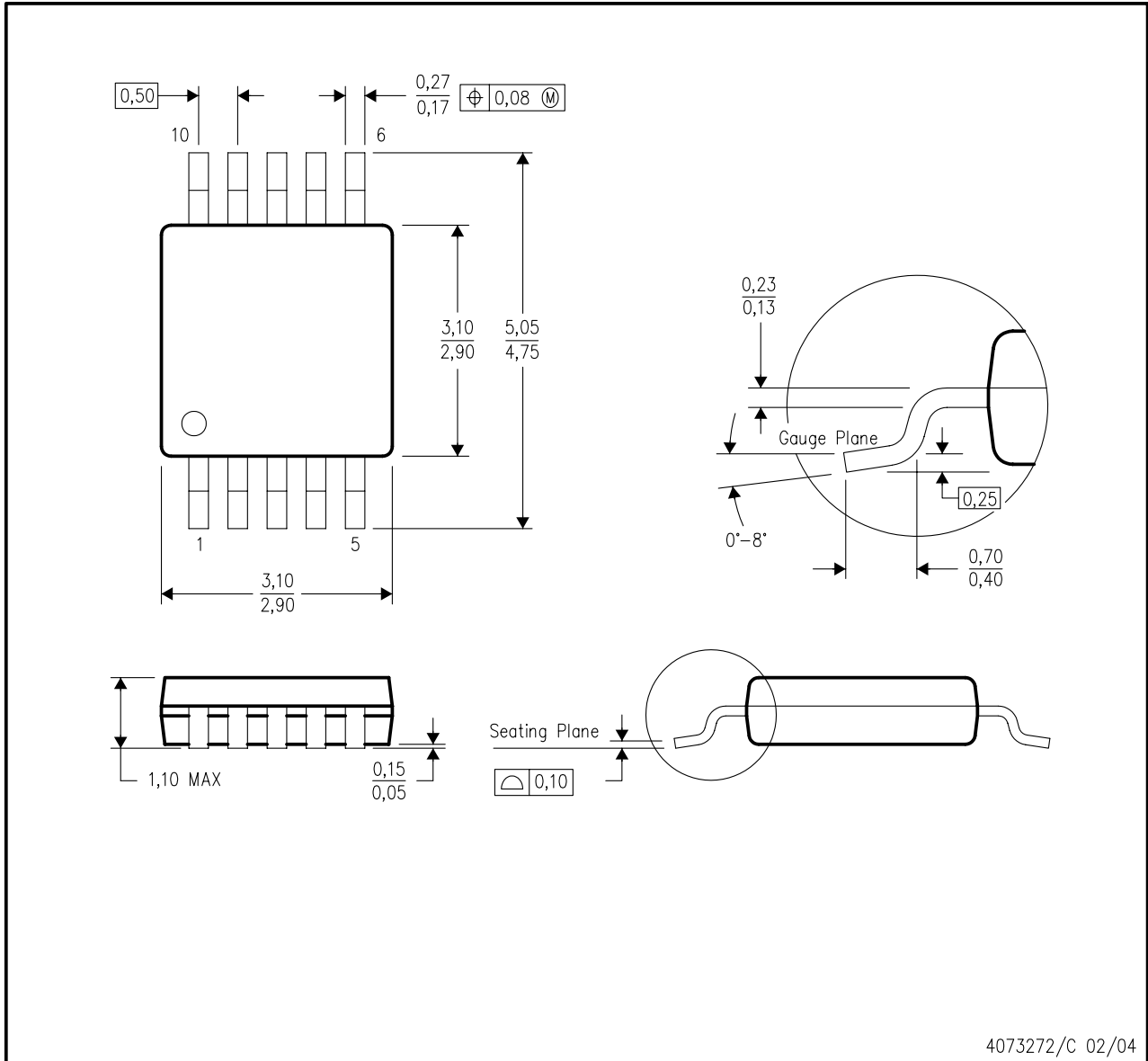

- NOTES:
- A. All linear dimensions are in millimeters.
 - B. This drawing is subject to change without notice.
 - C. Body dimensions do not include mold flash or protrusion.
 - D. Falls within JEDEC MO-187 variation BA.

D (R-PDSO-G14)

PLASTIC SMALL-OUTLINE PACKAGE

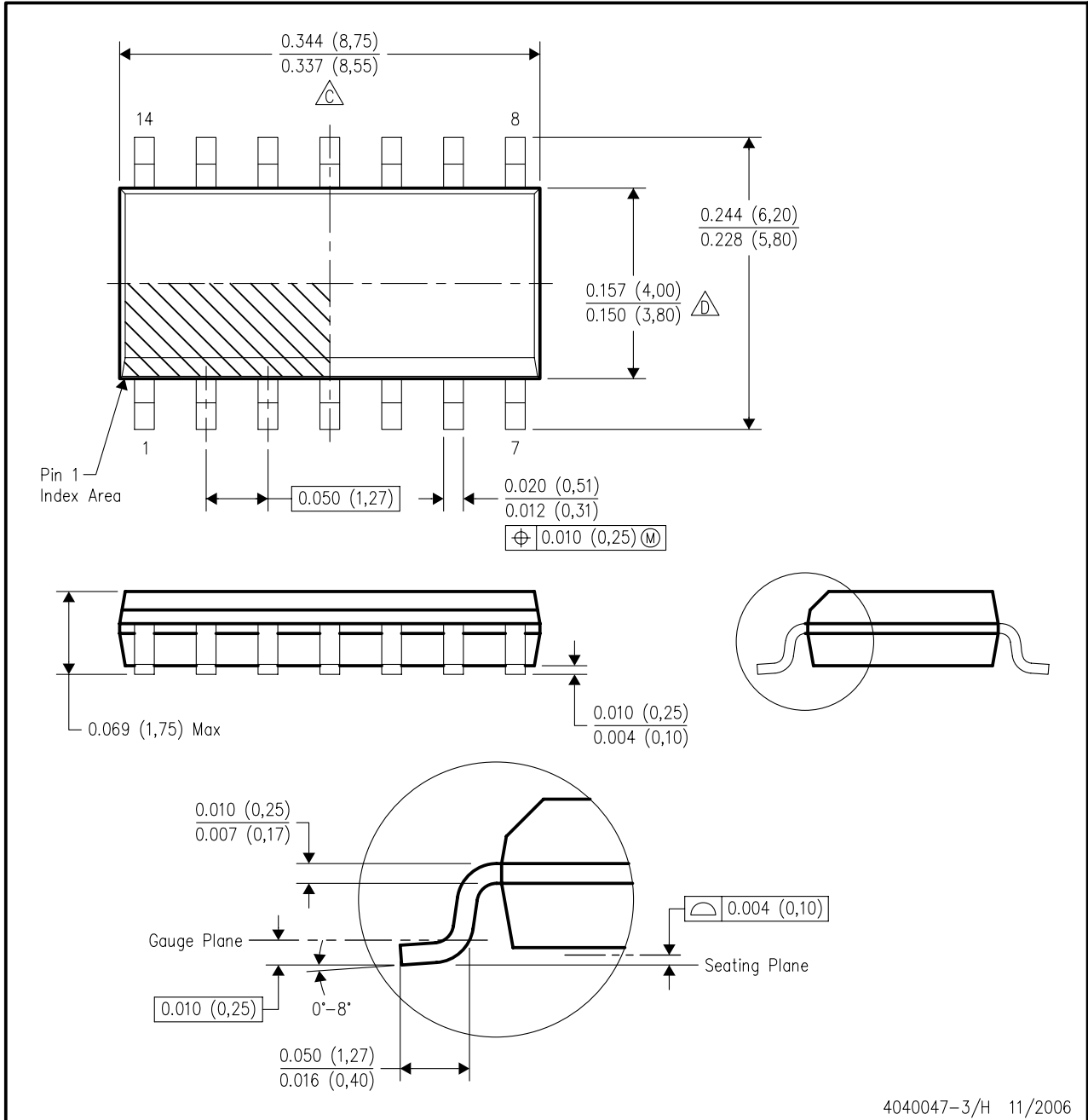

- NOTES:
- A. All linear dimensions are in inches (millimeters).
 - B. This drawing is subject to change without notice.
 - Body length does not include mold flash, protrusions, or gate burrs. Mold flash, protrusions, or gate burrs shall not exceed .006 (0,15) per end.
 - Body width does not include interlead flash. Interlead flash shall not exceed .017 (0,43) per side.
 - E. Reference JEDEC MS-012 variation AB.

MECHANICAL DATA

D (R-PDSO-G8)

PLASTIC SMALL-OUTLINE PACKAGE

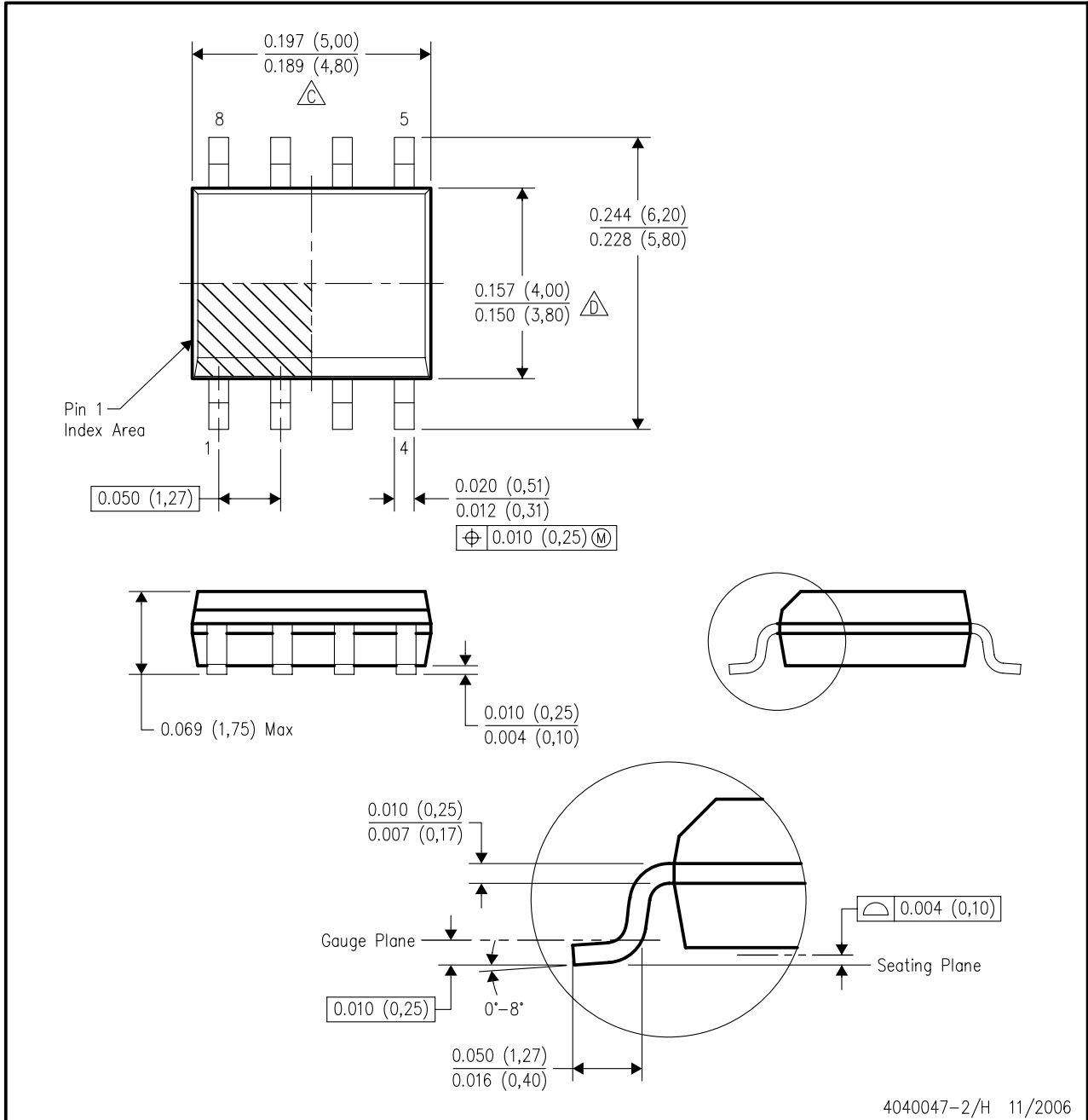

- NOTES:
- A. All linear dimensions are in inches (millimeters).
 - B. This drawing is subject to change without notice.
 - Body length does not include mold flash, protrusions, or gate burrs. Mold flash, protrusions, or gate burrs shall not exceed .006 (0,15) per end.
 - Body width does not include interlead flash. Interlead flash shall not exceed .017 (0,43) per side.
 - E. Reference JEDEC MS-012 variation AA.

MECHANICAL DATA

MTSS001C – JANUARY 1995 – REVISED FEBRUARY 1999

PW (R-PDSO-G**)

PLASTIC SMALL-OUTLINE PACKAGE

14 PINS SHOWN

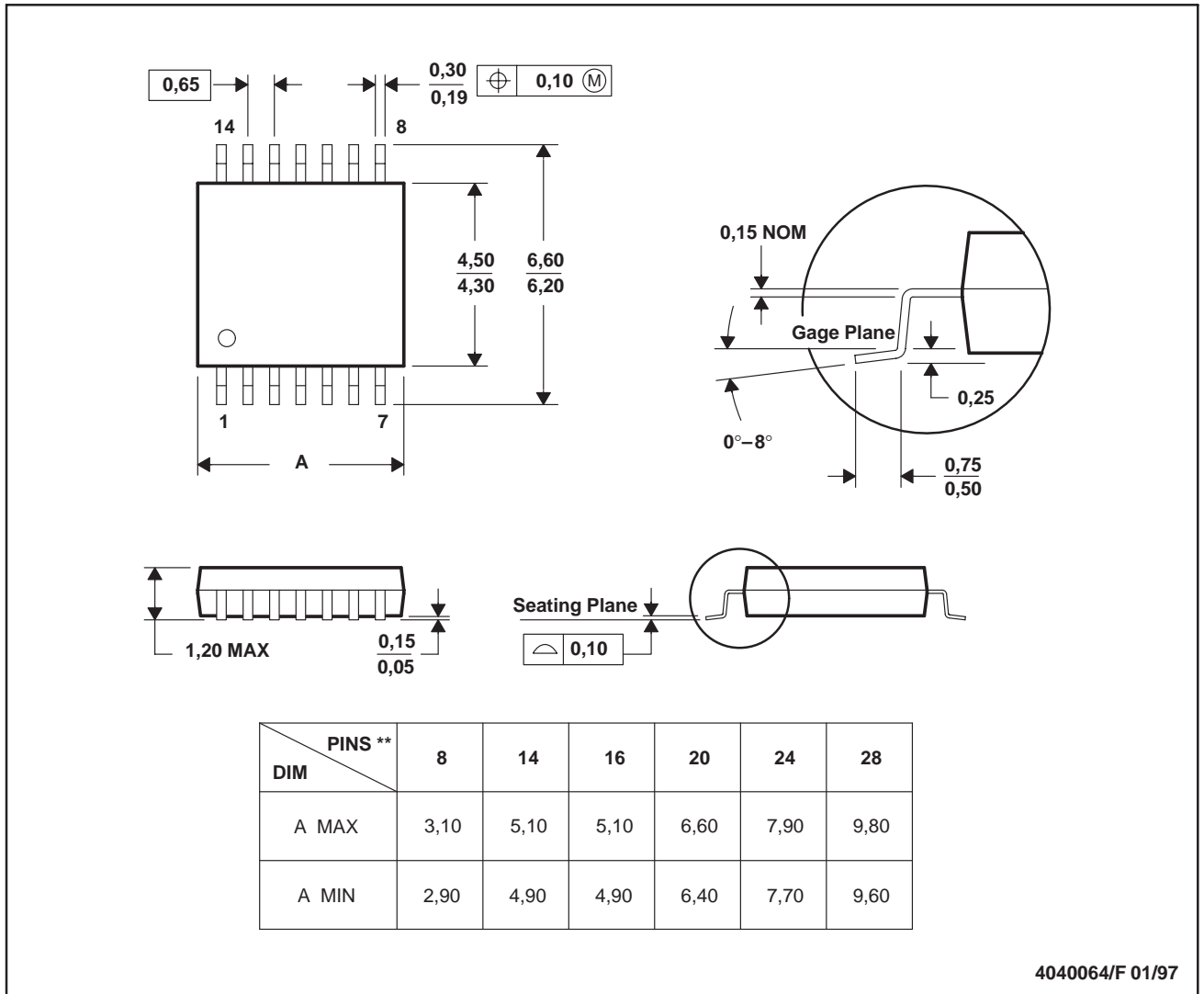

4040064/F 01/97

- NOTES: A. All linear dimensions are in millimeters.
 B. This drawing is subject to change without notice.
 C. Body dimensions do not include mold flash or protrusion not to exceed 0,15.
 D. Falls within JEDEC MO-153



POST OFFICE BOX 655303 • DALLAS, TEXAS 75265

IMPORTANT NOTICE

Texas Instruments Incorporated and its subsidiaries (TI) reserve the right to make corrections, modifications, enhancements, improvements, and other changes to its products and services at any time and to discontinue any product or service without notice. Customers should obtain the latest relevant information before placing orders and should verify that such information is current and complete. All products are sold subject to TI's terms and conditions of sale supplied at the time of order acknowledgment.

TI warrants performance of its hardware products to the specifications applicable at the time of sale in accordance with TI's standard warranty. Testing and other quality control techniques are used to the extent TI deems necessary to support this warranty. Except where mandated by government requirements, testing of all parameters of each product is not necessarily performed.

TI assumes no liability for applications assistance or customer product design. Customers are responsible for their products and applications using TI components. To minimize the risks associated with customer products and applications, customers should provide adequate design and operating safeguards.

TI does not warrant or represent that any license, either express or implied, is granted under any TI patent right, copyright, mask work right, or other TI intellectual property right relating to any combination, machine, or process in which TI products or services are used. Information published by TI regarding third-party products or services does not constitute a license from TI to use such products or services or a warranty or endorsement thereof. Use of such information may require a license from a third party under the patents or other intellectual property of the third party, or a license from TI under the patents or other intellectual property of TI.

Reproduction of TI information in TI data books or data sheets is permissible only if reproduction is without alteration and is accompanied by all associated warranties, conditions, limitations, and notices. Reproduction of this information with alteration is an unfair and deceptive business practice. TI is not responsible or liable for such altered documentation. Information of third parties may be subject to additional restrictions.

Resale of TI products or services with statements different from or beyond the parameters stated by TI for that product or service voids all express and any implied warranties for the associated TI product or service and is an unfair and deceptive business practice. TI is not responsible or liable for any such statements.

TI products are not authorized for use in safety-critical applications (such as life support) where a failure of the TI product would reasonably be expected to cause severe personal injury or death, unless officers of the parties have executed an agreement specifically governing such use. Buyers represent that they have all necessary expertise in the safety and regulatory ramifications of their applications, and acknowledge and agree that they are solely responsible for all legal, regulatory and safety-related requirements concerning their products and any use of TI products in such safety-critical applications, notwithstanding any applications-related information or support that may be provided by TI. Further, Buyers must fully indemnify TI and its representatives against any damages arising out of the use of TI products in such safety-critical applications.

TI products are neither designed nor intended for use in military/aerospace applications or environments unless the TI products are specifically designated by TI as military-grade or "enhanced plastic." Only products designated by TI as military-grade meet military specifications. Buyers acknowledge and agree that any such use of TI products which TI has not designated as military-grade is solely at the Buyer's risk, and that they are solely responsible for compliance with all legal and regulatory requirements in connection with such use.

TI products are neither designed nor intended for use in automotive applications or environments unless the specific TI products are designated by TI as compliant with ISO/TS 16949 requirements. Buyers acknowledge and agree that, if they use any non-designated products in automotive applications, TI will not be responsible for any failure to meet such requirements.

Following are URLs where you can obtain information on other Texas Instruments products and application solutions:

Products		Applications	
Amplifiers	amplifier.ti.com	Audio	www.ti.com/audio
Data Converters	dataconverter.ti.com	Automotive	www.ti.com/automotive
DSP	dsp.ti.com	Broadband	www.ti.com/broadband
Interface	interface.ti.com	Digital Control	www.ti.com/digitalcontrol
Logic	logic.ti.com	Military	www.ti.com/military
Power Mgmt	power.ti.com	Optical Networking	www.ti.com/opticalnetwork
Microcontrollers	microcontroller.ti.com	Security	www.ti.com/security
RFID	www.ti-rfid.com	Telephony	www.ti.com/telephony
Low Power Wireless	www.ti.com/lpw	Video & Imaging	www.ti.com/video
		Wireless	www.ti.com/wireless

Mailing Address: Texas Instruments, Post Office Box 655303, Dallas, Texas 75265
Copyright © 2007, Texas Instruments Incorporated