

## Audio Analog Switch

### FEATURES

- Wide Operating Voltage Range (2 to 14 V)
- Low Distortion (typ. 0.004%)
- Wide Dynamic Range (typ. 6 V<sub>P-P</sub>)
- Low Output Impedance (typ. 20 Ω)
- Low Switching Noise (typ. 3 mV)
- Output Parallel Connection Possible

### APPLICATIONS

- Audio Systems
- Radio Cassettes

### DESCRIPTION

The TK15329M is an Analog Switch IC that was developed for audio frequency. The function is to select one output from two inputs and has a floating position too. The channel can be changed by two control levels and the device includes two circuits. The TK15329M has a mono-power supply and the input bias is a supply type from outside. Because the distortion is very low, the TK15329M fits various signals switching. It is best suited for Hi-Fi devices. Operating voltage is wide, the circuit plan is simple. The TK15329M is available in a small plastic surface mount package (SSOP-12).

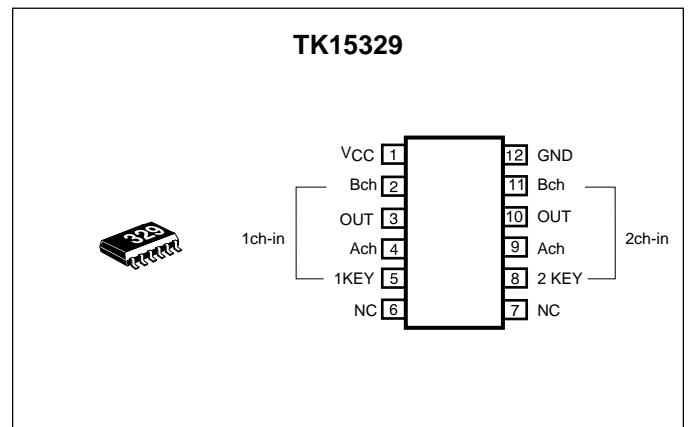

**ORDERING INFORMATION**

TK15329M □□

└─ Tape/Reel Code

TAPE/REEL CODE  
TL: Tape Left

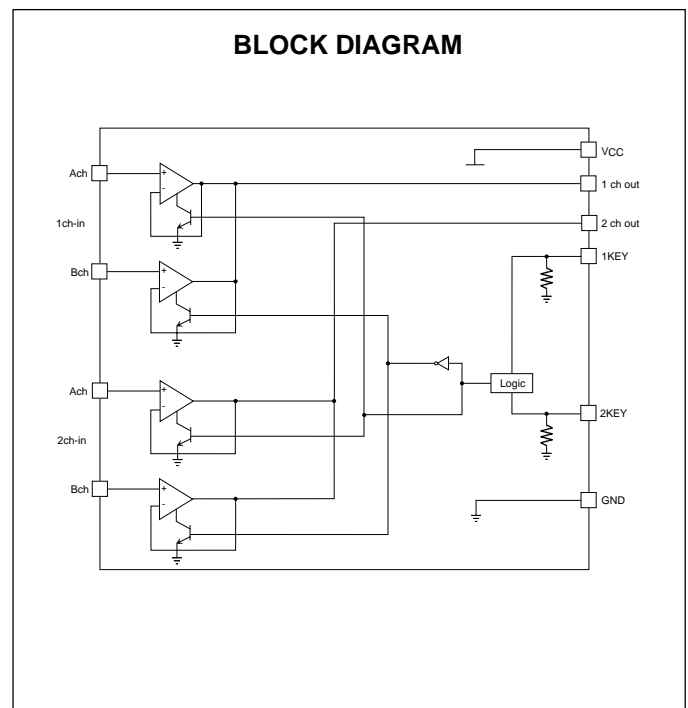

# TK15329

## ABSOLUTE MAXIMUM RATINGS

Supply Voltage ..... 15 V  
 Power Dissipation (Note 5) ..... 350 mW  
 Storage Temperature Range ..... -55 to +150 °C  
 Operating Temperature Range ..... -20 to +75 °C  
**CONTROL SECTION**  
 Input Voltage ..... -0.3 V to  $V_{CC} + 0.3$  V

**ANALOG SWITCH SECTION**  
 Signal Input Voltage ..... -0.3 V to  $V_{CC} + 0.3$  V  
 Signal Output Current ..... 3 mA  
 Operating Voltage Range ..... 2 to 14 V  
 Maximum Input Frequency ..... 100 kHz

## TK15329M ELECTRICAL CHARACTERISTICS

Test conditions:  $V_{CC} = 8.0$  V,  $T_A = 25$  °C, unless otherwise specified.

| SYMBOL                       | PARAMETER                          | TEST CONDITIONS                         | MIN             | TYP       | MAX             | UNITS      |
|------------------------------|------------------------------------|---|-----------------|-----------|-----------------|------------|
| $I_{CC}$                     | Supply Current                     |   |                 | 3.5       | 5.5             | mA         |
| <b>KEY CONTROL SECTION</b>   |                                    |   |                 |           |                 |            |
| $V_{IL}$                     | Input Voltage Low Level            | Note 1                                  | -0.3            |           | +0.8            | V          |
| $V_{IH}$                     | Input Voltage High Level           |   | 1.8             |           | $V_{CC} + 0.3$  | V          |
| $Z_{IN}$                     | Input Impedance                    |   |                 | 50        |                 | k $\Omega$ |
| <b>ANALOG SWITCH SECTION</b> |                                    |   |                 |           |                 |            |
| THD                          | Total Harmonic Distortion          | $V_{IN} = 1$ Vrms, $f = 1$ kHz          |                 | 0.003     | 0.006           | %          |
| $N_L$                        | Residual Noise                     | Note 2                                  |                 |           | 10              | $\mu$ Vrms |
| ISO                          | Isolation                          | $V_{IN} = 1$ Vrms, $F = 10$ kHz, Note 3 |                 |           | -75             | dB         |
| SEP                          | Separation                         | $V_{IN} = 1$ Vrms, $f = 10$ kHz, Note 3 |                 |           | -80             | dB         |
| DYN                          | Maximum Input Signal Level         | $f = 1$ kHz, THD = 0.1%                 | 2.0             |           |                 | Vrms       |
| GVA                          | Voltage Gain                       | $f = \sim 20$ kHz                       |                 | 0         |                 | dB         |
| $V_{cent}$                   | Input-Output Terminal Voltage      | $V_{OUT} =$ Supply voltage from outside | $V_{OUT} - 0.2$ | $V_{OUT}$ | $V_{OUT} + 0.2$ | V          |
| $\Delta V_{cent}$            | Output Terminal Voltage Difference | Between same channel                    |                 | 3         | 7               | mV         |
| $I_{IN}$                     | Input Bias Current                 | Note 4                                  |                 | 0.5       |                 | $\mu$ A    |
| $Z_{OUT}$                    | Output Impedance                   | DC Impedance                            |                 | 20        |                 | $\Omega$   |

- Note 1: The KEY input equivalent circuit is shown in Figure A. When the control pin is open, it is outputted at low level. The TK15329M is controlled by two values and the function table is described in the block diagram.
- Note 2: The specification means a value as measurement-input terminal connects to ground through a capacitor.
- Note 3: ISO is a cross talk between A channel and B channel, SEP is a cross talk between 1 channel and 2 channel. The specification means a value as measurement-input terminal connects to ground through 10 k $\Omega$  resistor and capacitor.
- Note 4: The standard application of the TK15329M is the direct connecting. In case of the capacitor connecting, the to supply a bias voltage from outside is unnecessary.
- Note 5: Power dissipation is 350 mW when mounted as recommended. Derate at 3.0 mW/°C for operation above 25°C.

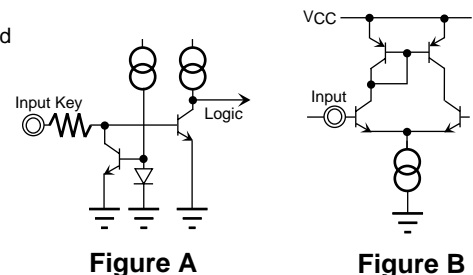

## TEST CIRCUITS AND METHODS

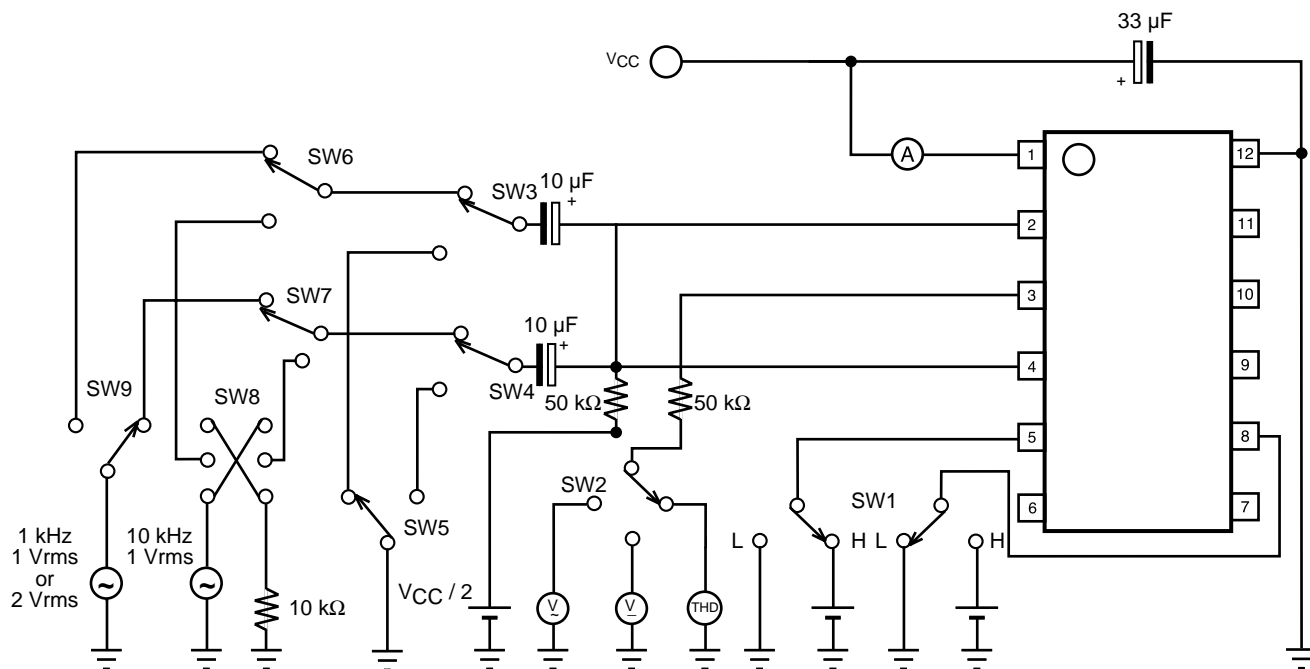

- 1: The above condition represents 1ch.
- 2: The above conditions distortion rate of 1-Ach and dynamic range measurement.
- 3: SW5 is for residual noise measurement.
- 4: SW8 is for cross talk (ISO or SEP) measurement.

## SUPPLY CURRENT (FIGURE 1)

This current is a consumption current with a nonloading condition.

- 1) Bias supply to Pin 2, 4, 9, 11. (This condition is the same with other measurements, omitted from the next for simplicity)
- 2) Connect Pin 5 to  $V_{CC}$ , Pin 8 is in the open condition or low level.
- 3) Measure the inflow current to Pin 1 from  $V_{CC}$ . This current is the supply current.

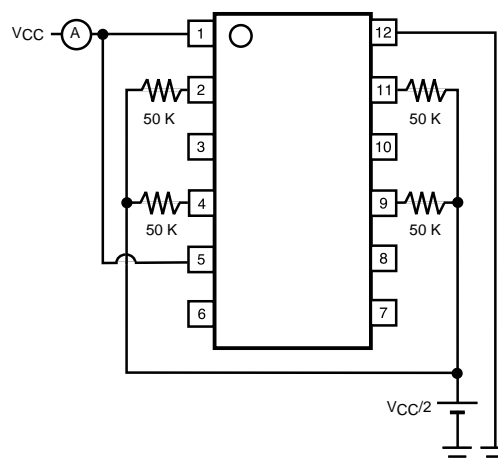

Figure 1

**TEST CIRCUITS AND METHODS (CONT.)**

**CONTROL LOW/HIGH LEVEL (FIGURE 2)**

This level is to measure the threshold level.

- 1) Input, the  $V_{CC}$  to Pin 1. (This condition is the same with other measurements, omitted from the next for simplicity)
- 2) Input to Pin 4 with sine wave ( $f = 1\text{ kHz}$ ,  $V_{IN} = 1\text{ Vrms}$ ).
- 3) Connect an oscilloscope to Pin 3.
- 4) Pin 8 is in the open condition or low level. Elevate Pin 5 voltage gradually from 0 V until the sine wave appears at the oscilloscope. This voltage is the threshold level, when the wave appears.

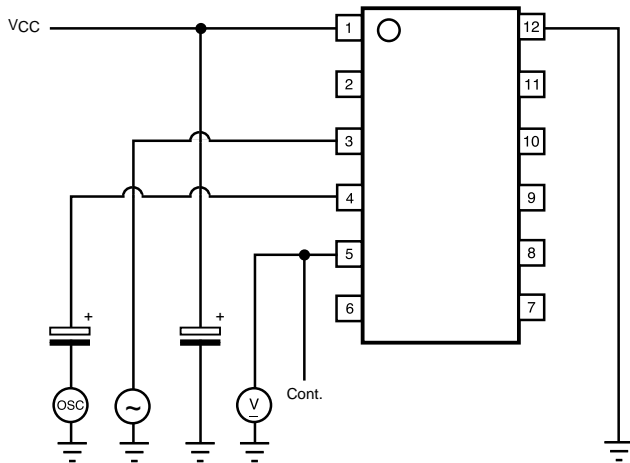

**Figure 2**

**CONTROL INPUT IMPEDANCE (FIGURE 3)**

This is the input resistance of control terminals.

- 1) Measure the inflow current from  $V_{CC}$  to Pin 5.
- 2) Calculate:

$$IMP = V_{CC} / \text{Inflow Current}$$

This resistance is the input impedance.

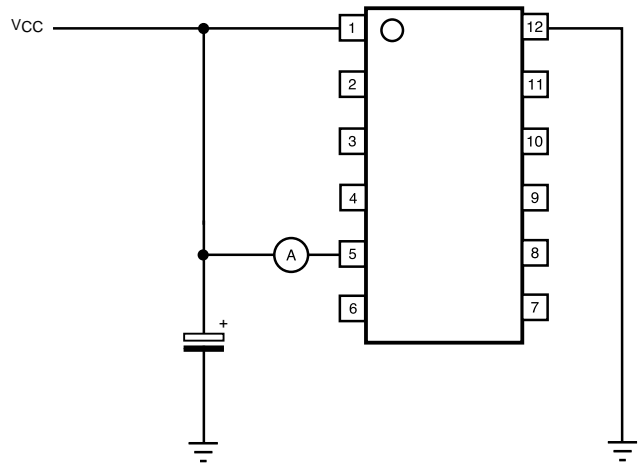

**Figure 3**

**TOTAL HARMONIC DISTORTION (FIGURE 4)**

Use the lower distortion oscillator for this measurement because distortion of the TK15329 is very low.

- 1) Connect  $V_{CC}$  to Pin 5, Pin 8 is in the open condition or low level.
- 2) Connect a distortion analyzer to Pin 3.
- 3) Input the sine wave (1 kHz, 1 Vrms) to Pin 4.
- 4) Measure the distortion of Pin 3. This value is the distortion of 1-Ach.
- 5) Next, reverse conditions at Pin 5 and Pin 8.
- 6) Input the same sine wave to Pin 2.
- 7) Measure in the same way. This value is the distortion of 1-Bch.

## TEST CIRCUITS AND METHODS (CONT.)

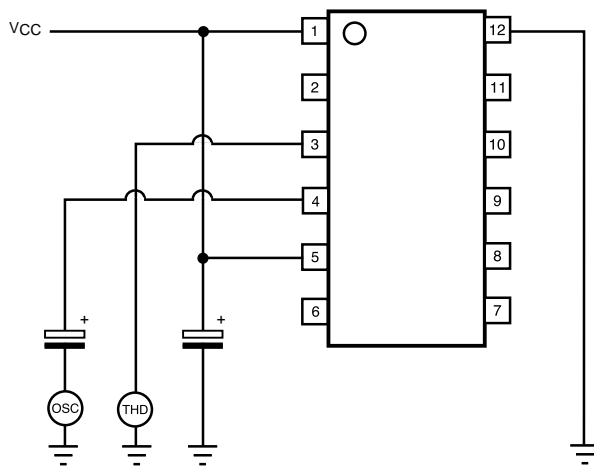

Figure 4

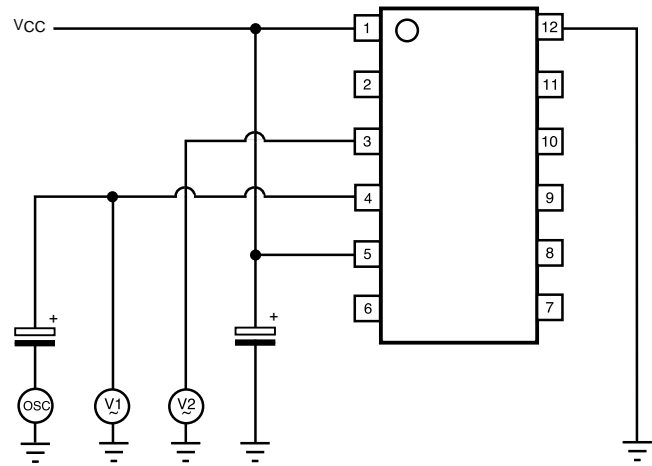

Figure 5

## VOLTAGE GAIN (FIGURE 5)

This is the output level against input level.

- 1) Connect  $V_{CC}$  to Pin 5, Pin 8 is in the open condition or low level.
- 2) Connect AC voltmeters to Pin 4 and Pin 3.  
(Using the same type meter is best)
- 3) Input a sine wave ( $f = \text{max. } 20 \text{ kHz, } 1 \text{ V}_{\text{rms}}$ ) to Pin 4.
- 4) Measure the level of Pin 4 and name this V1.
- 5) Measure the level of Pin 3 and name this V2.
- 6) Calculate  $\text{Gain} = 20 \text{ Log } ((|V2 - V1|)/V1)$   
 $V1 < V2 + \text{Gain}, V1 > V2 - \text{Gain}$   
 This value is the voltage gain of 1-Ach.
- 7) Next, reverse conditions at Pin 5 and Pin 8.
- 8) Input the same sine wave to Pin 2.
- 9) Measure and calculate in the same way.  
 This value is the voltage gain of 1-Bch.

## MAXIMUM INPUT LEVEL (FIGURE 6)

This measurement measures at output side.

- 1) Connect  $V_{CC}$  to Pin 5, Pin 8 is low level or open.
- 2) Connect a distortion analyzer and an AC voltmeter to Pin 3.
- 3) Input a sine wave (1 kHz) to Pin 4 and elevate the voltage gradually until the distortion gets to 0.1%.
- 4) When the distortion amounts to 0.1%, stop elevating and measure the AC level of Pin 3.  
 This value is the maximum input level of 1-Ach.
- 5) Next, reverse conditions at Pin 5 and Pin 8.
- 6) Input the same sine wave to Pin 2.
- 7) Measure in the same way.  
 This value is the maximum input level of 1-Bch.

**TEST CIRCUITS AND METHODS (CONT.)**

**RESIDUAL NOISE (FIGURE 7)**

This value is not S/N ratio. This is a noise which occurs from the device itself.

- 1) Connect  $V_{CC}$  to Pin 5, Pin 8 is the open condition or low level.
- 2) Connect an AC volt meter to Pin 3.
- 3) Connect a capacitor from Pin 4 to GND.
- 4) Measure AC voltage of Pin 3. This value is the noise of 1-Ach. If the influence of noise from outside exists, use optional filters.
- 5) Next, reverse conditions at Pin 5 and Pin 8.
- 6) Connect to GND through a capacitor from Pin 2.
- 7) Measure in the same way.  
This value is the noise level of 1-Bch.

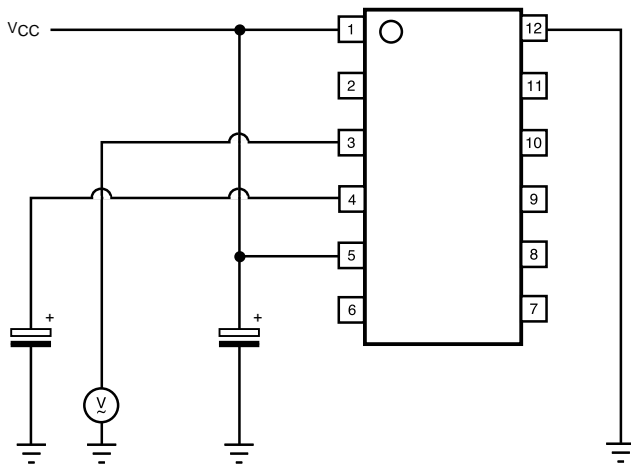
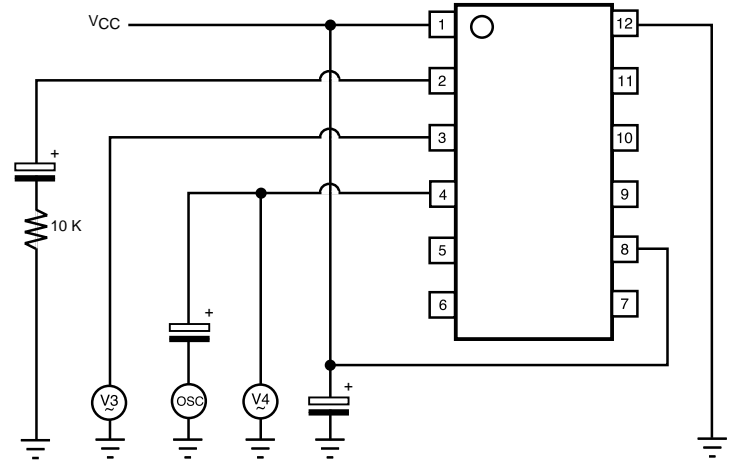

**Figure 7**

**ISOLATION (FIGURE 8)**

This is the cross talk between Ach and Bch.

- 1) Connect  $V_{CC}$  to Pin 8, Pin 5 is in the open condition or low level.
- 2) Connect AC volt meters to Pin 4 and Pin 3.
- 3) Connect a capacitor and a resistance in series to GND from Pin 2.
- 4) Input a sine wave (10 kHz, 1 Vrms) to Pin 4.
- 5) Measure the level of Pin 4 and name this V4.
- 6) Measure the level of Pin 3 and name this V3.
- 7) Calculate:  
$$ISO = 20 \text{ Log } (V3 / V4)$$
  
This value is the isolation to Bch from Ach.
- 8) Next, reverse conditions at Pin 5 and Pin 8.
- 9) Change line of Pin 2 and Pin 4.
- 10) Input the same sine wave to Pin 2.
- 11) Measure and calculate in the same way.  
This value is the isolation to Ach from Bch.



**Figure 8**

## TEST CIRCUITS AND METHODS (CONT.)

### SEPARATION (FIGURE 9)

This is the cross talk between 1ch and 2ch.

- 1) Connect either Pin 5 or Pin 8 to  $V_{CC}$ . One side pin is low level or open.
- 2) Connect AC volt meters to Pin 4 (or Pin 2) and Pin 10.
- 3) Connect Pin 9 and Pin 11 to GND through capacitors and a resistance.
- 4) Input a sine wave (10 kHz, 1 Vrms) to Pin 2 and Pin 4.
- 5) Measure the level of Pin 4 and name this V5.
- 6) Measure the level of Pin 10 and name this V6.
- 7) Calculate:

$$SEP = 20 \text{ Log } (V6 / V5)$$

This value is the separation to 2ch from 1ch.

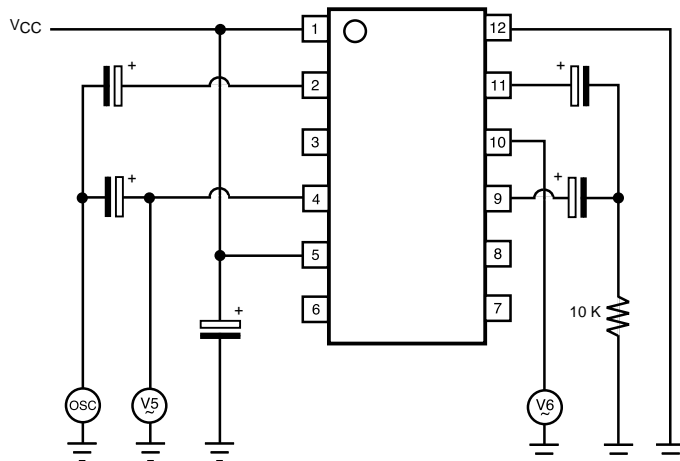

Figure 9

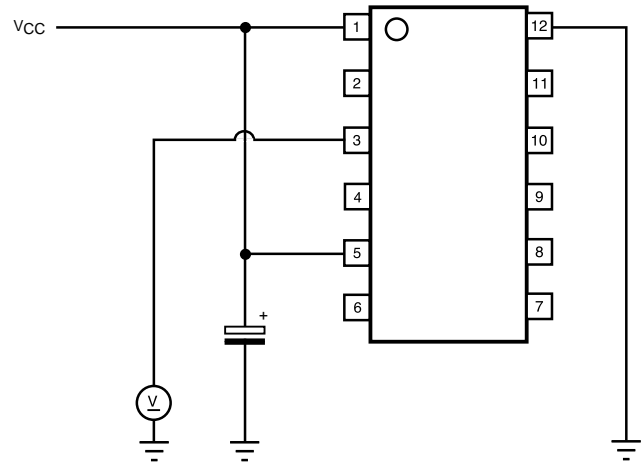

Figure 10

### OUTPUT TERMINAL DIFFERENCE

This is the DC output voltage difference between Ach and Bch. This is calculated by using values measured at the I/O Terminal Voltage.

$$\Delta V_{cent} = | (1 - A_{ch} \text{ value}) - (1 - B_{ch} \text{ value}) |$$

This value is the voltage difference of 1ch.

### I/O TERMINAL VOLTAGE (FIGURE 10)

This is the DC voltage of input and output.

Because the input and the output are nearly equal, only the output is measured.

- 1) Connect  $V_{CC}$  to Pin 5, Pin 8 is in the open condition or low level.
- 2) Connect a DC volt meter to Pin 3 and measure.  
This value is the terminal voltage of 1-Ach.
- 3) Next, reverse conditions at Pin 5 and Pin 8.
- 4) Measure in the same way.  
This value is the terminal voltage of 1-Bch.

**TYPICAL PERFORMANCE CHARACTERISTICS**

$V_{CC} = 8\text{ V}$ ,  $T_A = 25\text{ }^\circ\text{C}$ , unless otherwise specified.

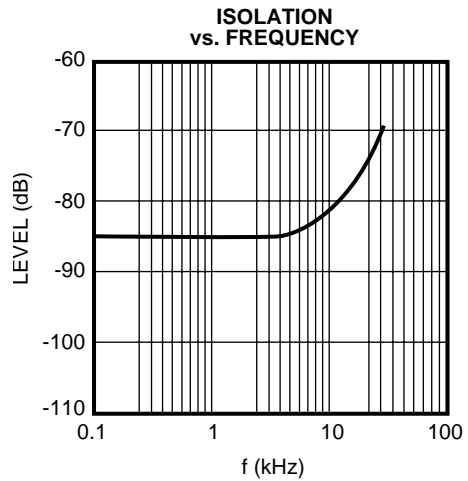
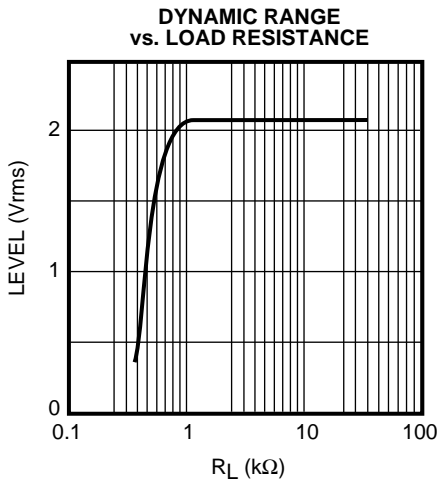
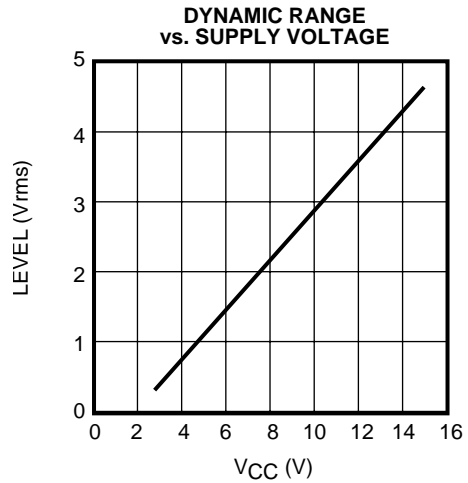
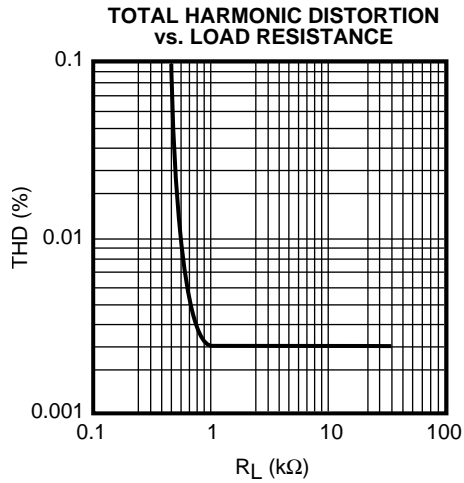
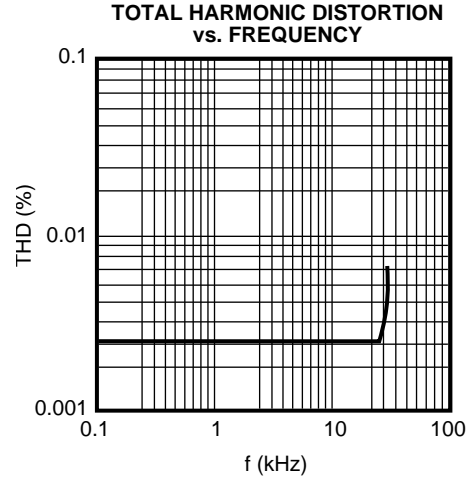
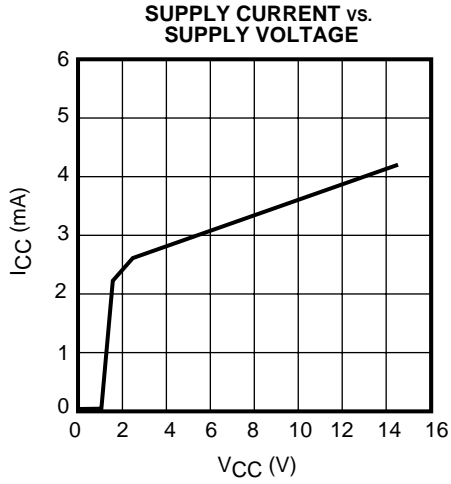



## TYPICAL PERFORMANCE CHARACTERISTICS

$V_{CC} = 8\text{ V}$ ,  $T_A = 25\text{ }^\circ\text{C}$ , unless otherwise specified.

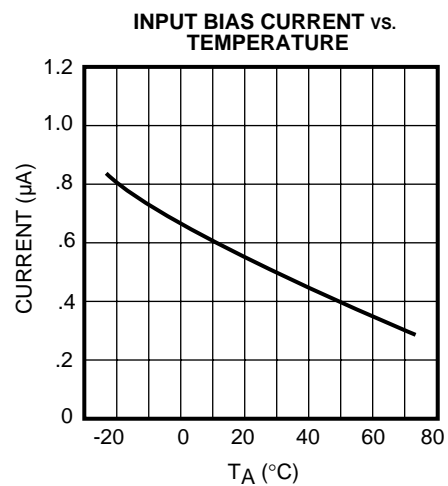
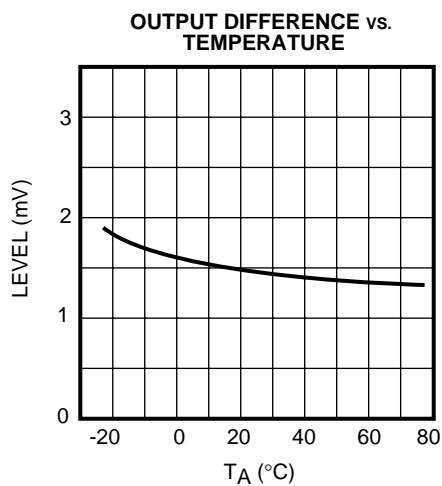
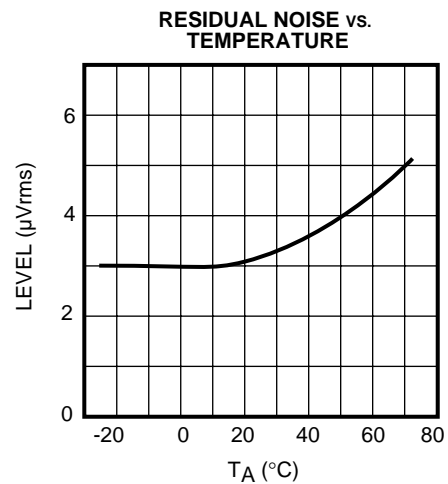
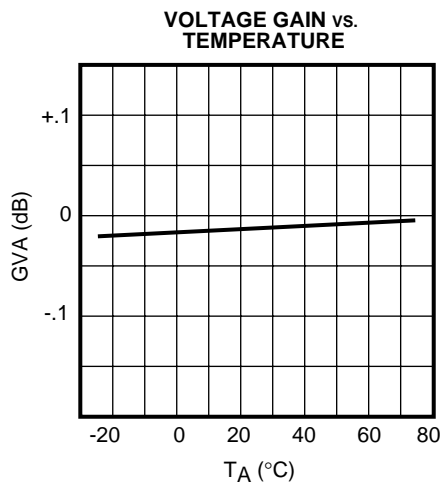
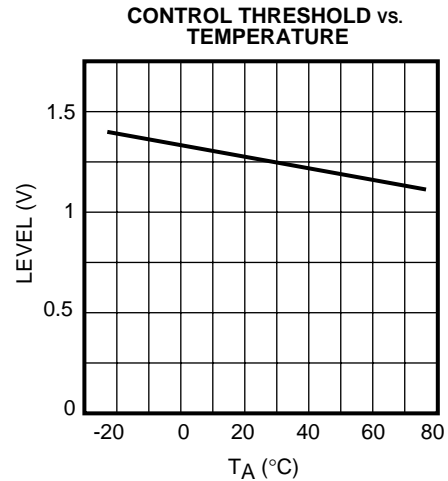
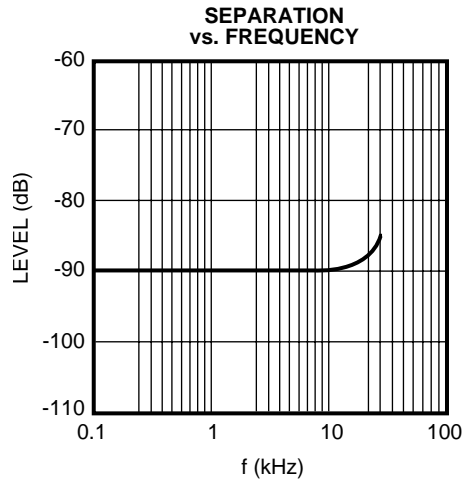

## FUNCTION TABLE

| 1KEY | 2KEY | OUT      |
|------|------|----------|
| Lo   | Lo   | Floating |
| Hi   | Lo   | Ach      |
| Lo   | Hi   | Bch      |
| Hi   | Hi   | Floating |

## TERMINAL VOLTAGE AND CIRCUIT

Condition:  $V_{CC} = 8\text{ V}$ .

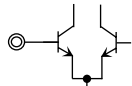
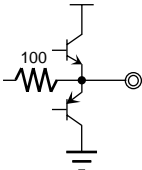
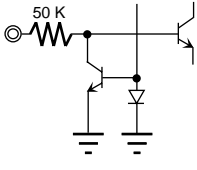
| PIN NO.           | ASSIGNMENT                                    | DC VOLTAGE           | CIRCUIT/FUNCTION   |
|-------------------|---|----------------------|--|
| 1                 | $V_{CC}$                                      | 8 V                  | Supply Voltage Pin   |
| 2<br>4<br>9<br>11 | IN A, IN B<br><br>Input: Open<br>Input: 4.0 V | <br><br>0 V<br>4 V   | <br>Signal Input Pin  |
| 3<br>10           | OUT<br><br>Input: Open<br>Input: 4.0 V        | <br><br>0.7 V<br>4 V | <br>Signal Output Pin |
| 5<br>8            | KEY   | 0 V                  | <br>Control Pin       |
| 12                | GND   | 0 V                  | Ground Pin   |
| 6<br>7            | NC  | Floating             | No Contact Pin   |

## APPLICATION INFORMATION

### KEY INPUT CIRCUIT

1ch and 2ch is separate action by each control keys. Figure 11 is an equivalence circuit of key input. If two keys are low level or high level at the same time then the output is floating condition. (See Terminal DC Voltage and Circuit table on page 9).

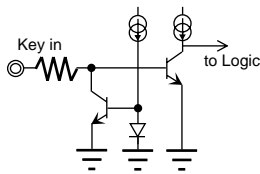

Figure 11

### SWITCHING TIME

This time is the signal change response time compared to the control key input signal. Figure 12 illustrates the timing chart.  $T = 2 \mu s$  typically.

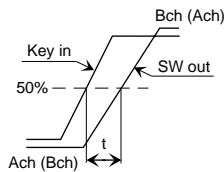

Figure 12

### APPLICATION

Figure 13 illustrates an example of a typical application. The standard application is to use direct coupling at the inputs and capacitor coupling at the outputs of the TK15329M. For characteristics of distortion and dynamic range versus  $R_L$ , refer to the graphs in the Typical Performance Characteristics. The TK15329M can also be used with direct coupling, but the characteristics will get worse (distortion, etc.). If capacitor coupling is desired, then it is recommended to use built-in type biased circuitry of the TK15327M. DC input bias voltage of TK15327M is  $V_{CC}/2 V$ .

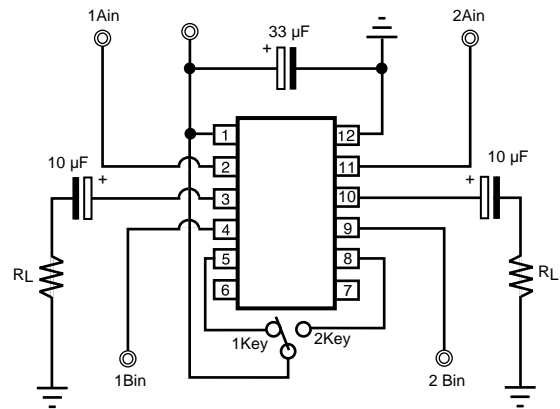

Figure 13

### CROSS TALK (ISOLATION AND SEPARATION)

Figure 14 is an example of a layout pattern. In the application of the TK15329M, the following must be considered. Because of the high impedance at the inputs, the capacitors can act as antennas to each other. If the parts are bigger, and the space between the capacitors is too narrow, then cross talk will increase. Therefore, when designing the printed circuit pattern, separate the input capacitors as far as possible and use as small a part as possible (e.g., surface mount types, etc.).

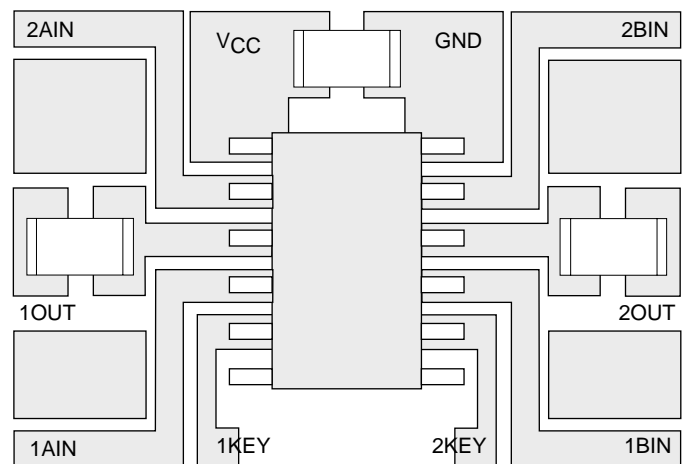

Figure 14

**APPLICATION INFORMATION (CONT.)**

**OUTPUT TERMINAL VOLTAGE DIFFERENCE**

This parameter is the output voltage difference between Ach and Bch, and appears when the channel changes from Ach to Bch, or changes to the reverse. Generally, this is called Switching Noise or Pop Noise. If this value is big and if this noise is amplified by the final amplifier and is outputted by the speakers, then it appears as a Shock Sound. Output terminal voltage difference of the TK15329M is a value that adds the internal bias difference and the off-set voltage difference. The off-set voltage difference is very small, its typical value is 3 mV, but the input bias is supplied from the outside.

So almost the output bias difference will be decided by the supply bias difference. The TK15329M has a floating position. Pay attention when operating as for the change timing of the two keys. If the floating condition is long, then the output voltage may fluctuate by  $R_L$  and the difference may appear larger. Toko can offer the "Muting IC" if users wish to mute Switching Noise.

**DIRECT TOUCH**

The signal input terminals:

Internal circuits are operated by constant current circuit, even if  $V_{CC}$  or GND is contacted, damage does not occur. The signal output terminal:

Outflow or inflow current is decided by ability of final transistor, but protection circuit is not attached. If GND or  $V_{CC}$  are contacted damage may occur. Pay attention to long time contact. Do not supply over the maximum rating. Referenced to GND, do not provide to all terminals over  $V_{CC} + 0.3 V$  or  $-0.3 V$ .

**DC SIGNAL INPUT**

The output of the TK15329M has a saturation voltage (both  $V_{CC}$  and GND sides about 1.0 V); accordingly the use of a DC signal is not recommend (e.g., the pulse signal etc.)

**NC TERMINAL**

NC terminals are not wired inside IC by bonding wire. NC terminals are not tested so do not connect at outside.

**FLOATING POSITION**

TK15329M has floating position and can increase optional channels. Figure 15 is an example to select one output from four inputs, and the change operates by four controls. This function is shown in the table below. If channels increase more, control keys will increase with the same number too. In this case the Decoder may be necessary. Each device and channel has individual output voltage values within a specification. When channels are increased caution the output terminal voltage difference too.

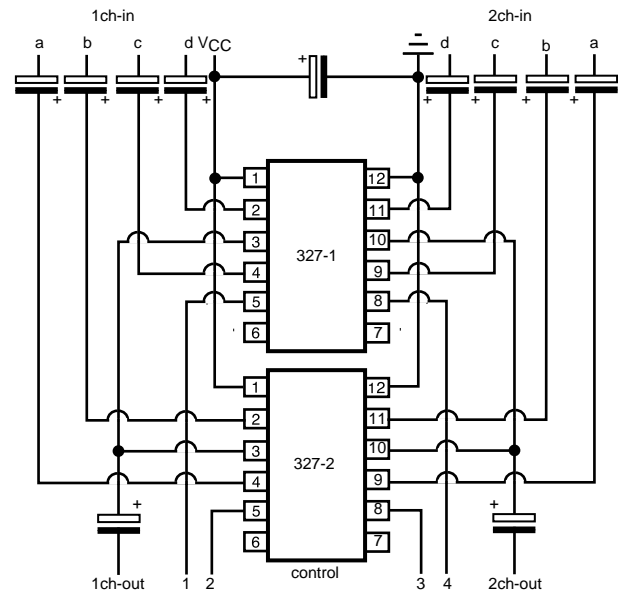

Figure 15

**FUNCTION TABLE**

| KEY NO. / OUTPUT | 1 | 2 | 3 | 4 |
|------------------|---|---|---|---|
| c                | H | L | L | L |
| a                | L | H | L | L |
| b                | L | L | H | L |
| d                | L | L | L | H |

When all is high level or low level, output is the floating. Plural high level is prohibited.

**NOTES**

**NOTES**

**NOTES**

PACKAGE OUTLINE

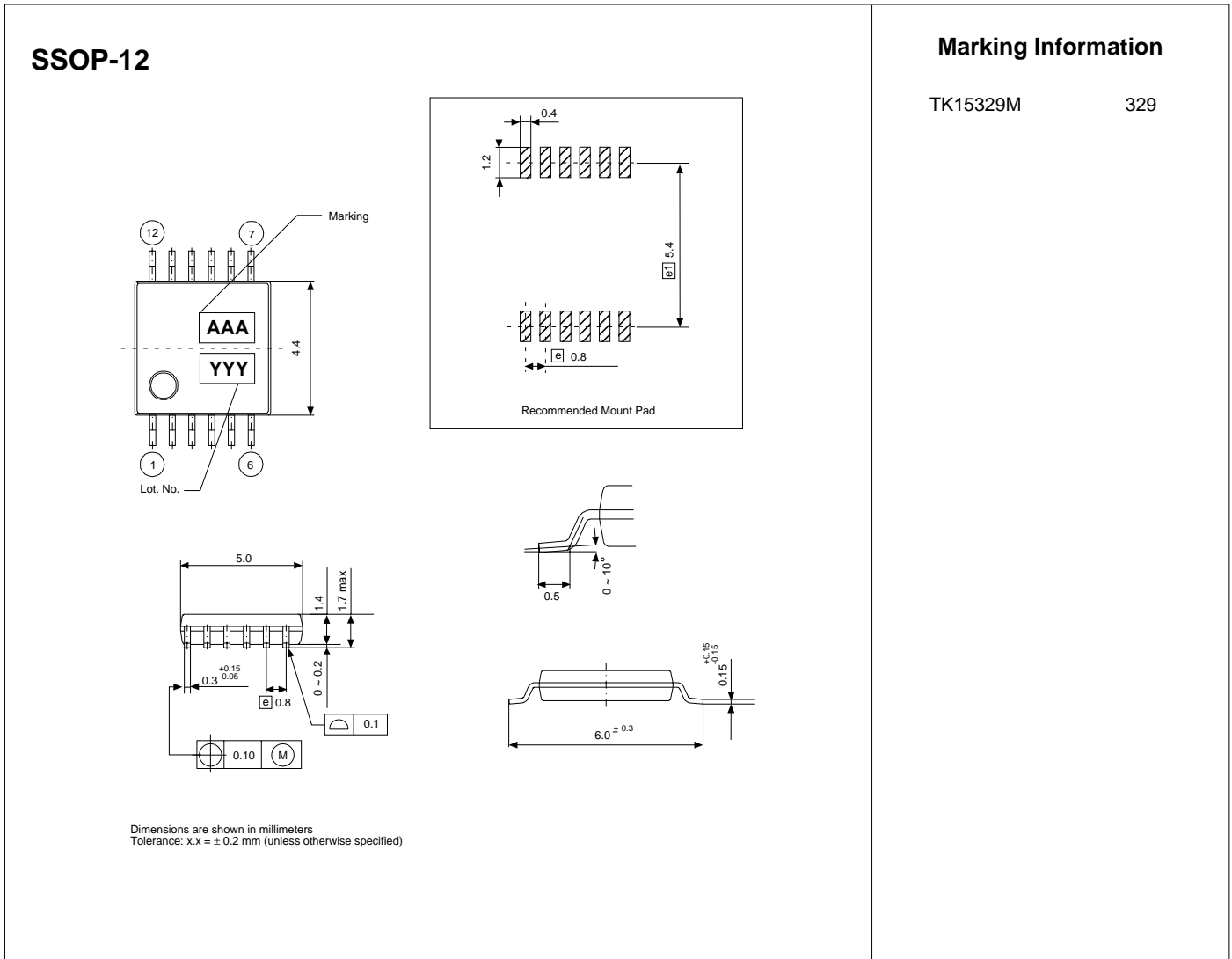

Toko America, Inc. Headquarters  
1250 Feehanville Drive, Mount Prospect, Illinois 60056  
Tel: (847) 297-0070 Fax: (847) 699-7864

TOKO AMERICA REGIONAL OFFICES

Midwest Regional Office  
Toko America, Inc.  
1250 Feehanville Drive  
Mount Prospect, IL 60056  
Tel: (847) 297-0070  
Fax: (847) 699-7864

Western Regional Office  
Toko America, Inc.  
2480 North First Street, Suite 260  
San Jose, CA 95131  
Tel: (408) 432-8281  
Fax: (408) 943-9790

Eastern Regional Office  
Toko America, Inc.  
107 Mill Plain Road  
Danbury, CT 06811  
Tel: (203) 748-6871  
Fax: (203) 797-1223

Semiconductor Technical Support  
Toko Design Center  
4755 Forge Road  
Colorado Springs, CO 80907  
Tel: (719) 528-2200  
Fax: (719) 528-2375

Visit our Internet site at <http://www.tokoam.com>

The information furnished by TOKO, Inc. is believed to be accurate and reliable. However, TOKO reserves the right to make changes or improvements in the design, specification or manufacture of its products without further notice. TOKO does not assume any liability arising from the application or use of any product or circuit described herein, nor for any infringements of patents or other rights of third parties which may result from the use of its products. No license is granted by implication or otherwise under any patent or patent rights of TOKO, Inc.