

TOSHIBA CMOS DIGITAL INTEGRATED CIRCUIT SILICON MONOLITHIC

TC74HC564AP, TC74HC564AF
TC74HC574AP, TC74HC574AF, TC74HC574AFW

OCTAL D-TYPE FLIP-FLOP WITH 3-STATE OUTPUT
 TC74HC564AP/AF **INVERTING**
 TC74HC574AP/AF/AFW **NON-INVERTING**

(Note) The JEDEC SOP (FW) is not available in Japan.

The TC74HC564A and HC574A are high speed CMOS OCTAL FLIP - FLOPs with 3 - STATE OUTPUT fabricated with silicon gate C²MOS technology.

They achieve the high speed operation similar to equivalent LSTTL while maintaining the CMOS low power dissipation.

These 8-bit D-type flip-flops are controlled by a clock input (CK) and an output enable input (\overline{OE}).

The TC74HC564A has inverting outputs, and the TC74HC574A has non-inverting outputs.

All inputs are equipped with protection circuits against static discharge or transient excess voltage.

FEATURES :

- High Speed..... $f_{MAX} = 62\text{MHz}(\text{typ.})$ at $V_{CC} = 5\text{V}$
- Low Power Dissipation..... $I_{CC} = 4\mu\text{A}(\text{Max.})$ at $T_a = 25^\circ\text{C}$
- High Noise Immunity..... $V_{NIH} = V_{NIL} = 28\% V_{CC} (\text{Min.})$
- Output Drive Capability..... 15 LSTTL Loads
- Symmetrical Output Impedance... $|I_{OH}| = I_{OL} = 6\text{mA}(\text{Min.})$
- Balanced Propagation Delays..... $t_{PLH} \approx t_{PHL}$
- Wide Operating Voltage Range... $V_{CC} (\text{opr.}) = 2\text{V} \sim 6\text{V}$
- Pin and Function Compatible with 74LS564/574

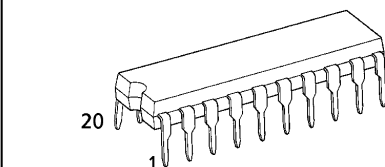

P (DIP20-P-300-2.54A)
Weight : 1.30g (Typ.)

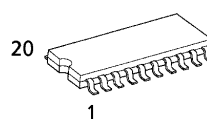

F (SOP20-P-300-1.27)
Weight : 0.22g (Typ.)

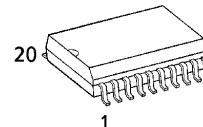

FW (SOL20-P-300-1.27)
Weight : 0.46g (Typ.)

PIN ASSIGNMENT

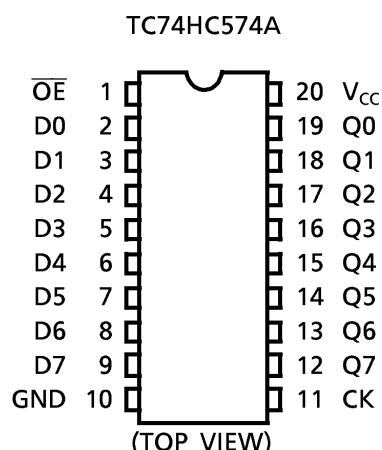
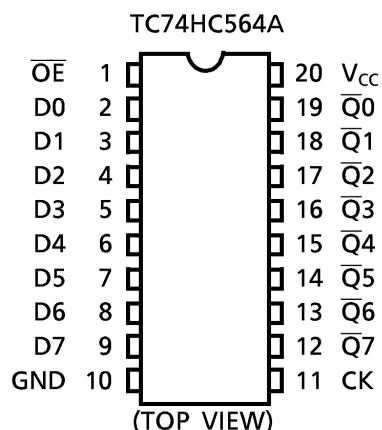

TRUTH TABLE

INPUTS			OUTPUTS	
\overline{OE}	CK	D	Q(574A)	\overline{Q} (564A)
H	X	X	Z	Z
L		X	Q_n	\overline{Q}_n
L		L	L	H
L		H	H	L

X : Don't Care
 Z : High Impedance
 $Q_n (\overline{Q}_n)$: No Change

980508EBA2

● TOSHIBA is continually working to improve the quality and the reliability of its products. Nevertheless, semiconductor devices in general can malfunction or fail due to their inherent electrical sensitivity and vulnerability to physical stress. It is the responsibility of the buyer, when utilizing TOSHIBA products, to observe standards of safety, and to avoid situations in which a malfunction or failure of a TOSHIBA product could cause loss of human life, bodily injury or damage to property. In developing your designs, please ensure that TOSHIBA products are used within specified operating ranges as set forth in the most recent products specifications. Also, please keep in mind the precautions and conditions set forth in the TOSHIBA Semiconductor Reliability Handbook.

IEC LOGIC SYMBOL

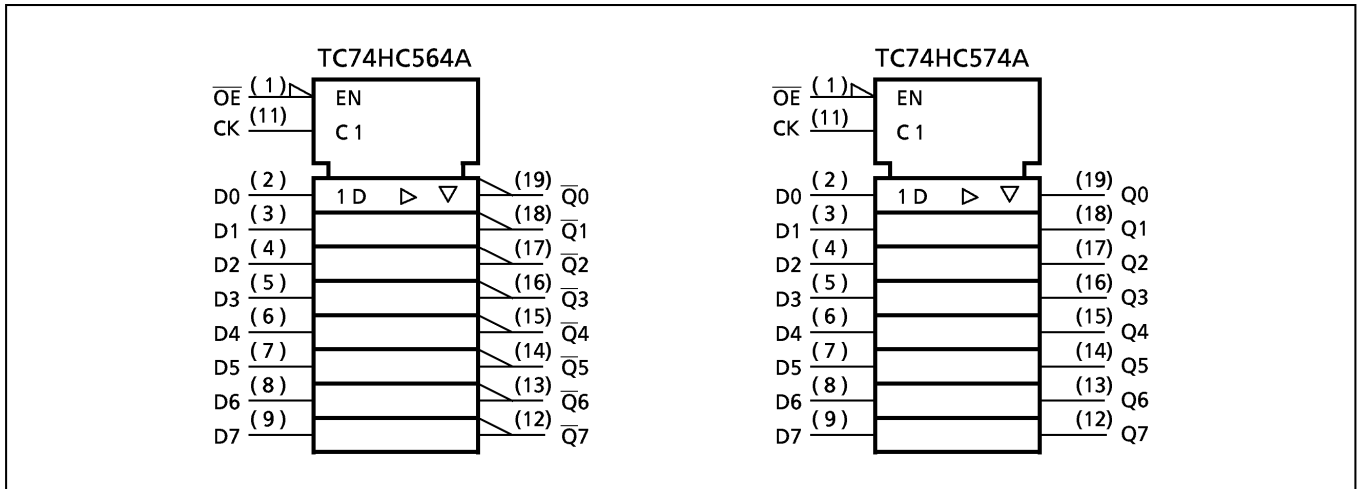

SYSTEM DIAGRAM

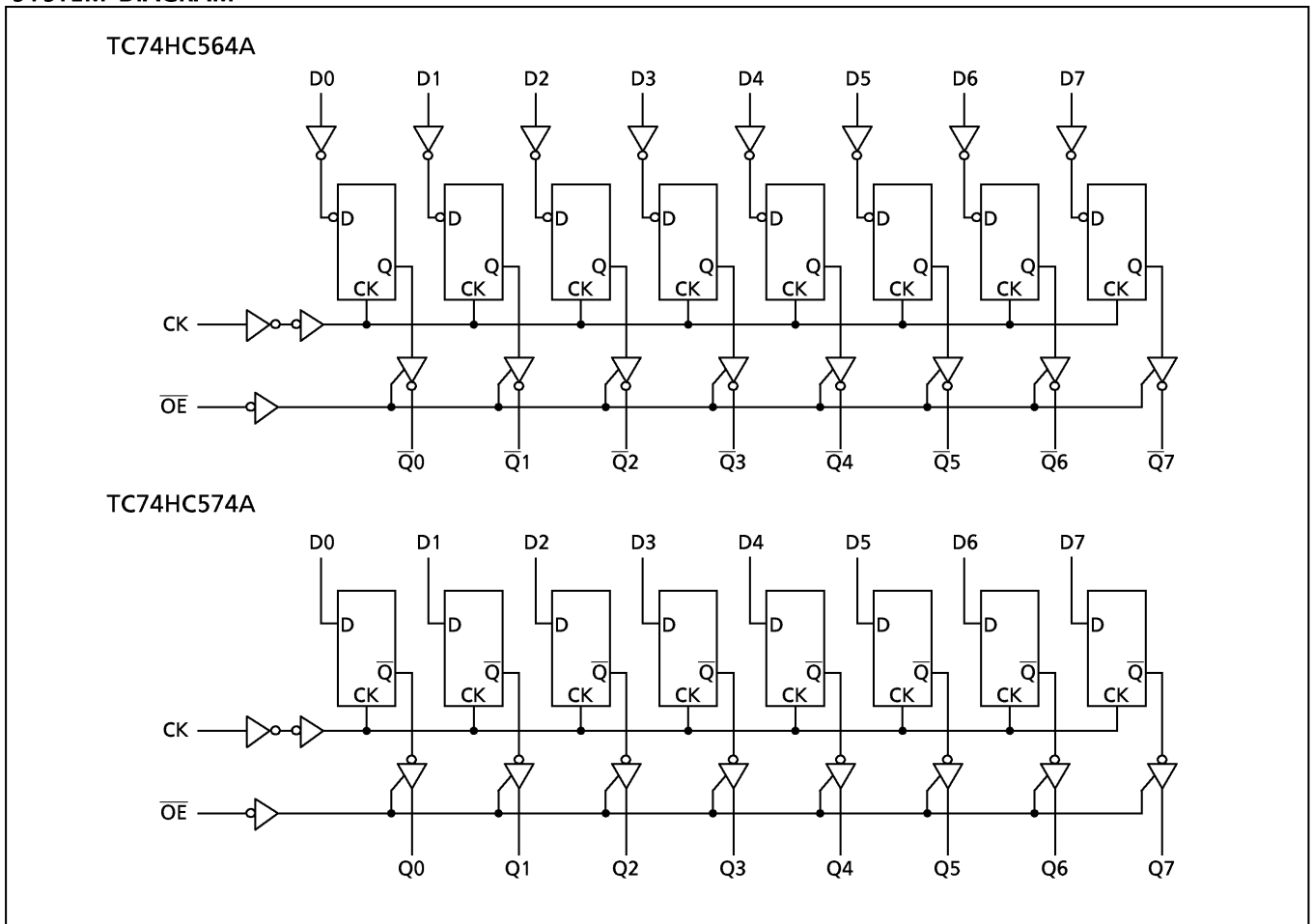

980508EBA2'

- The products described in this document are subject to foreign exchange and foreign trade laws.
- The information contained herein is presented only as a guide for the applications of our products. No responsibility is assumed by TOSHIBA CORPORATION for any infringements of intellectual property or other rights of the third parties which may result from its use. No license is granted by implication or otherwise under any intellectual property or other rights of TOSHIBA CORPORATION or others.
- The information contained herein is subject to change without notice.

ABSOLUTE MAXIMUM RATINGS

PARAMETER	SYMBOL	VALUE	UNIT
Supply Voltage Range	V_{CC}	-0.5~7	V
DC Input Voltage	V_{IN}	-0.5~ $V_{CC}+0.5$	V
DC Output Voltage	V_{OUT}	-0.5~ $V_{CC}+0.5$	V
Input Diode Current	I_{IK}	±20	mA
Output Diode Current	I_{OK}	±20	mA
DC Output Current	I_{OUT}	±35	mA
DC V_{CC} /Ground Current	I_{CC}	±75	mA
Power Dissipation	P_D	500 (DIP)* / 180 (SOP)	mW
Storage Temperature	T_{stg}	-65~150	°C

*500mW in the range of $T_a = -40^{\circ}\text{C} \sim 65^{\circ}\text{C}$. From $T_a = 65^{\circ}\text{C}$ to 85°C a derating factor of $-10\text{mW}/^{\circ}\text{C}$ shall be applied until 300mW.

RECOMMENDED OPERATING CONDITIONS

PARAMETER	SYMBOL	VALUE	UNIT
Supply Voltage	V_{CC}	2~6	V
Input Voltage	V_{IN}	0~ V_{CC}	V
Output Voltage	V_{OUT}	0~ V_{CC}	V
Operating Temperature	T_{opr}	-40~85	°C
Input Rise and Fall Time	t_r, t_f	0~1000 ($V_{CC} = 2.0\text{V}$) 0~500 ($V_{CC} = 4.5\text{V}$) 0~400 ($V_{CC} = 6.0\text{V}$)	ns

DC ELECTRICAL CHARACTERISTICS

PARAMETER	SYMBOL	TEST CONDITION	V_{CC} (V)	$T_a = 25^{\circ}\text{C}$			$T_a = -40 \sim 85^{\circ}\text{C}$		UNIT	
				MIN.	TYP.	MAX.	MIN.	MAX.		
High - Level Input Voltage	V_{IH}		2.0 4.5 6.0	1.50 3.15 4.20	— — —	— — —	1.50 3.15 4.20	— — —	V	
Low - Level Input Voltage	V_{IL}		2.0 4.5 6.0	— — —	— — —	0.50 1.35 1.80	— — —	0.50 1.35 1.80	— — —	V
High - Level Output Voltage	V_{OH}	$V_{IN} = V_{IH}$ or V_{IL}	$I_{OH} = -20\mu\text{A}$	2.0 4.5 6.0	1.9 4.4 5.9	2.0 4.5 6.0	— — —	1.9 4.4 5.9	— — —	V
				4.5 6.0	4.18 5.68	4.31 5.80	— —	4.13 5.63	— —	
Low - Level Output Voltage	V_{OL}	$V_{IN} = V_{IH}$ or V_{IL}	$I_{OL} = 20\mu\text{A}$	2.0 4.5 6.0	— — —	0.0 0.0 0.0	0.1 0.1 0.1	— — —	0.1 0.1 0.1	V
				4.5 6.0	— —	0.17 0.18	0.26 0.26	— —	0.33 0.33	
3 - State Output Off - State Current	I_{OZ}	$V_{IN} = V_{IH}$ or V_{IL} $V_{OUT} = V_{CC}$ or GND	6.0	—	—	±0.5	—	±5.0	μA	
Input Leakage Current	I_{IN}	$V_{IN} = V_{CC}$ or GND	6.0	—	—	±0.1	—	±1.0		
Quiescent Supply Current	I_{CC}	$V_{IN} = V_{CC}$ or GND	6.0	—	—	4.0	—	40.0		

TIMING REQUIREMENTS (Input $t_r = t_f = 6ns$)

PARAMETER	SYMBOL	TEST CONDITION	V_{CC} (V)	Ta = 25°C		Ta = -40~85°C	UNIT
				TYP.	LIMIT	LIMIT	
Minimum Pulse Width (CK)	$t_{W(H)}$ $t_{W(L)}$		2.0	—	75	95	ns
			4.5	—	15	19	
			6.0	—	13	16	
Minimum Set-up Time (Dn)	t_s		2.0	—	75	95	
			4.5	—	15	19	
			6.0	—	13	16	
Minimum Hold Time (Dn)	t_h		2.0	—	0	0	
			4.5	—	0	0	
			6.0	—	0	0	
Clock Frequency	f		2.0	—	6	5	MHz
			4.5	—	31	24	
			6.0	—	36	28	

AC ELECTRICAL CHARACTERISTICS (Input $t_r = t_f = 6ns$)

PARAMETER	SYMBOL	TEST CONDITION	CL (pF)	V_{CC} (V)	Ta = 25°C			Ta = -40~85°C		UNIT
					MIN.	TYP.	MAX.	MIN.	MAX.	
Output Transition Time	t_{TLH} t_{THL}		50	2.0	—	25	60	—	75	ns
				4.5	—	7	12	—	15	
				6.0	—	6	10	—	13	
Propagation Delay Time (CK-Q, \bar{Q})	t_{pLH} t_{pHL}		50	2.0	—	70	150	—	190	
				4.5	—	20	30	—	38	
				6.0	—	15	26	—	33	
			$R_L = 1k\Omega$	150	2.0	—	88	190	—	240
					4.5	—	25	38	—	48
					6.0	—	19	33	—	41
Output Enable time	t_{pZL} t_{pZH}	$R_L = 1k\Omega$	50	2.0	—	48	125	—	155	
				4.5	—	15	25	—	31	
				6.0	—	12	21	—	26	
			$R_L = 1k\Omega$	150	2.0	—	60	165	—	205
					4.5	—	20	33	—	41
					6.0	—	16	28	—	35
Output Disable time	t_{pLZ} t_{pHZ}	$R_L = 1k\Omega$	50	2.0	—	34	125	—	155	
				4.5	—	17	25	—	31	
				6.0	—	15	21	—	26	
Maximum Clock Frequency	f_{MAX}		50	2.0	6	17	—	5	—	MHz
				4.5	31	50	—	24	—	
				6.0	36	59	—	28	—	
Input Capacitance	C_{IN}				—	5	10	—	pF	
Output Capacitance	C_{OUT}				—	10	—	—		
Power Dissipation Capacitance	$C_{PD} (1)$				—	54	—	—		

Note (1) C_{PD} is defined as the value of the internal equivalent capacitance which is calculated from the operating current consumption without load.

Average operating current can be obtained by the equation :

$$I_{CC} (opr) = C_{PD} \cdot V_{CC} \cdot f_{IN} + I_{CC} / 8 \text{ (per bit)}$$

And the total C_{PD} when n pcs. of Flip Flop operate can be gained by the following equation:

$$C_{PD} (total) = 39 + 15 \cdot n$$

DIP 20PIN OUTLINE DRAWING (DIP20-P-300-2.54A)

Unit in mm

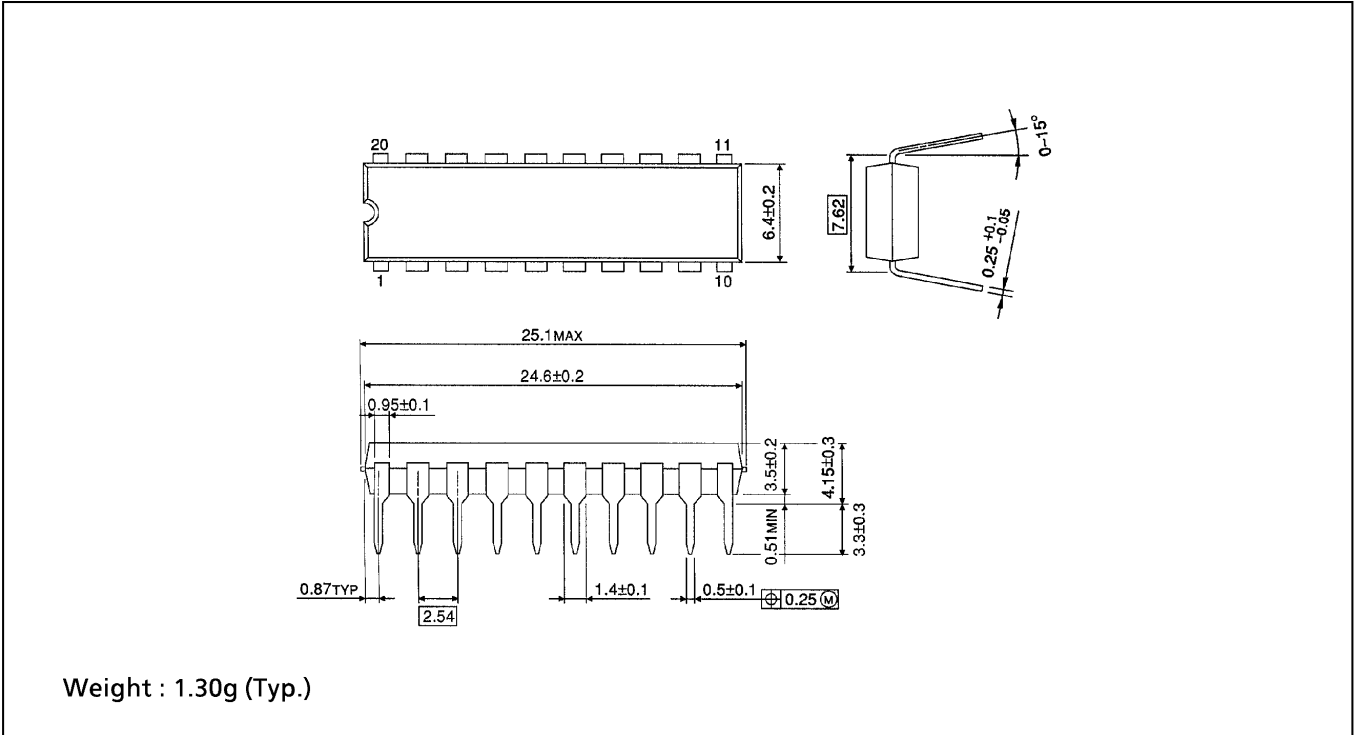

SOP 20PIN (200mil BODY) OUTLINE DRAWING (SOP20-P-300-1.27)

Unit in mm

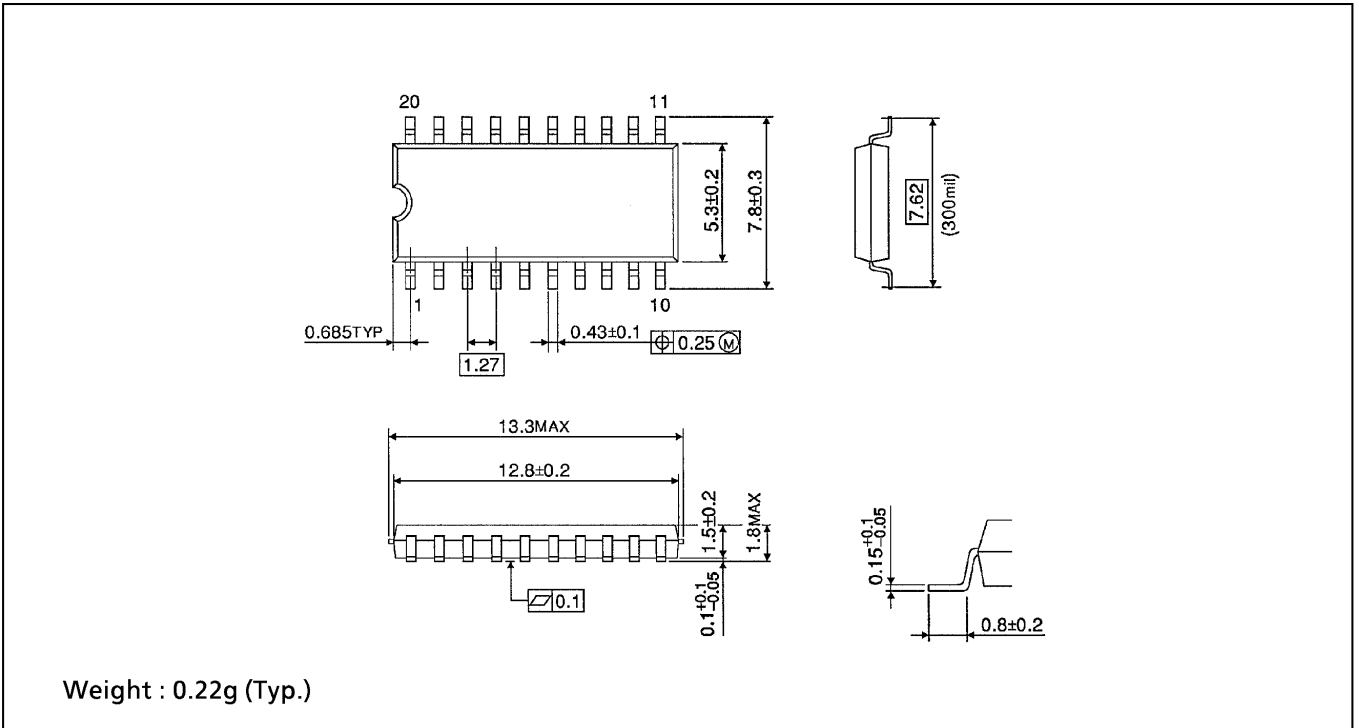

SOP 20PIN (300mil BODY) OUTLINE DRAWING (SOL20-P-300-1.27)

Unit in mm

(Note) This package is not available in Japan.

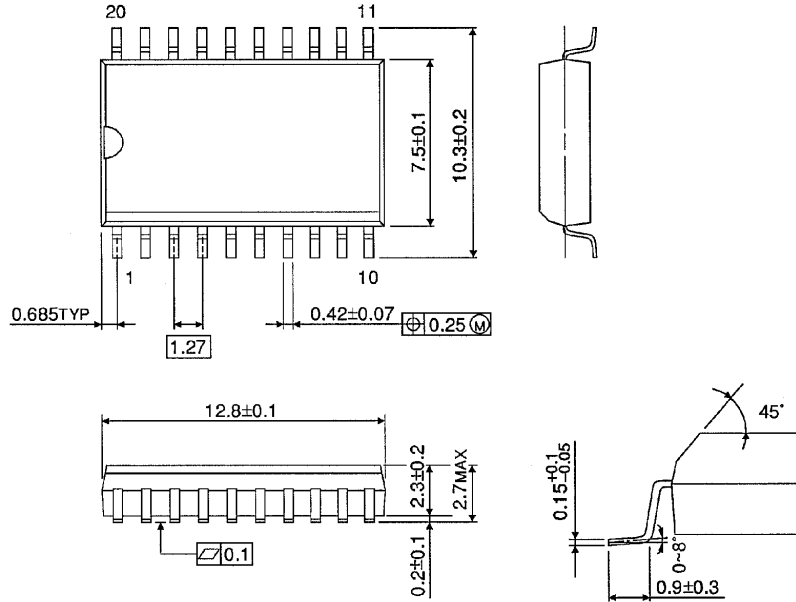

Weight : 0.46g (Typ.)